

Art. Nr. 58-428-17

# «VENEDIG»

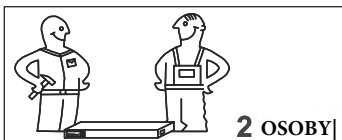

120 min.



2 OSOBY|

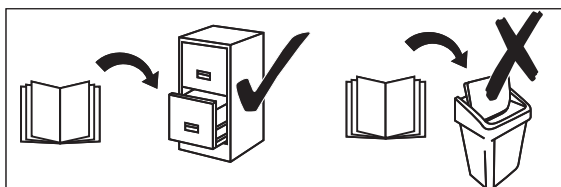
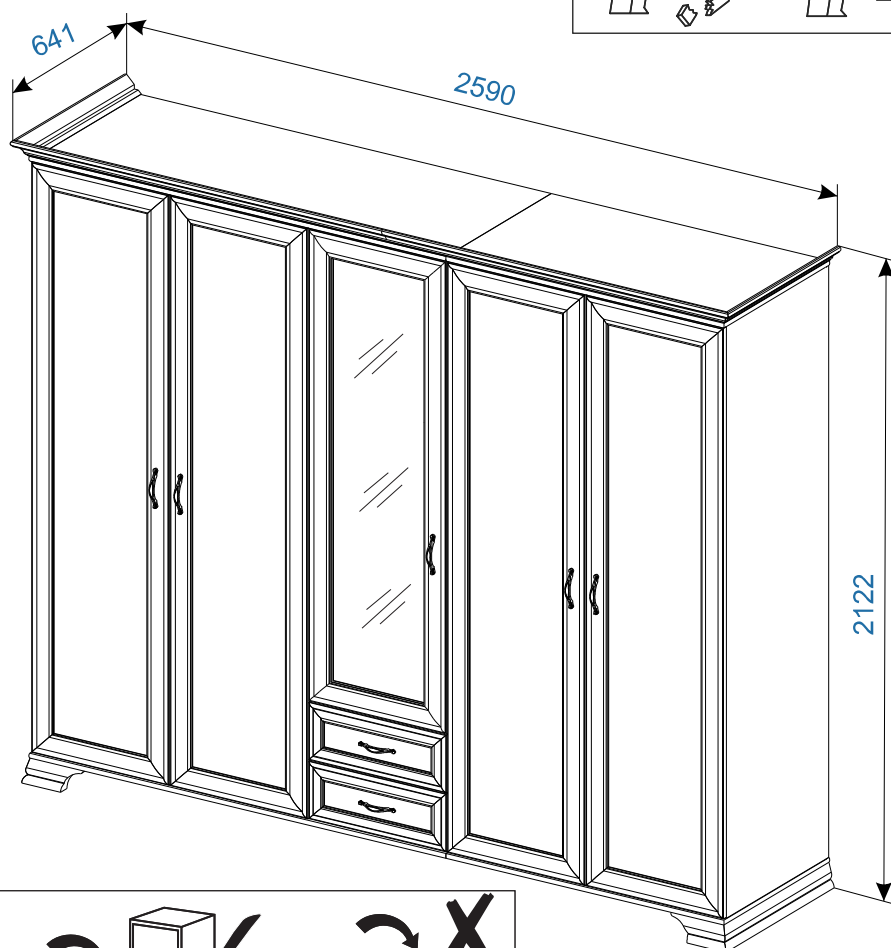
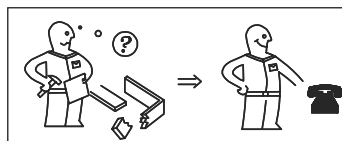
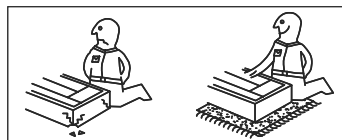



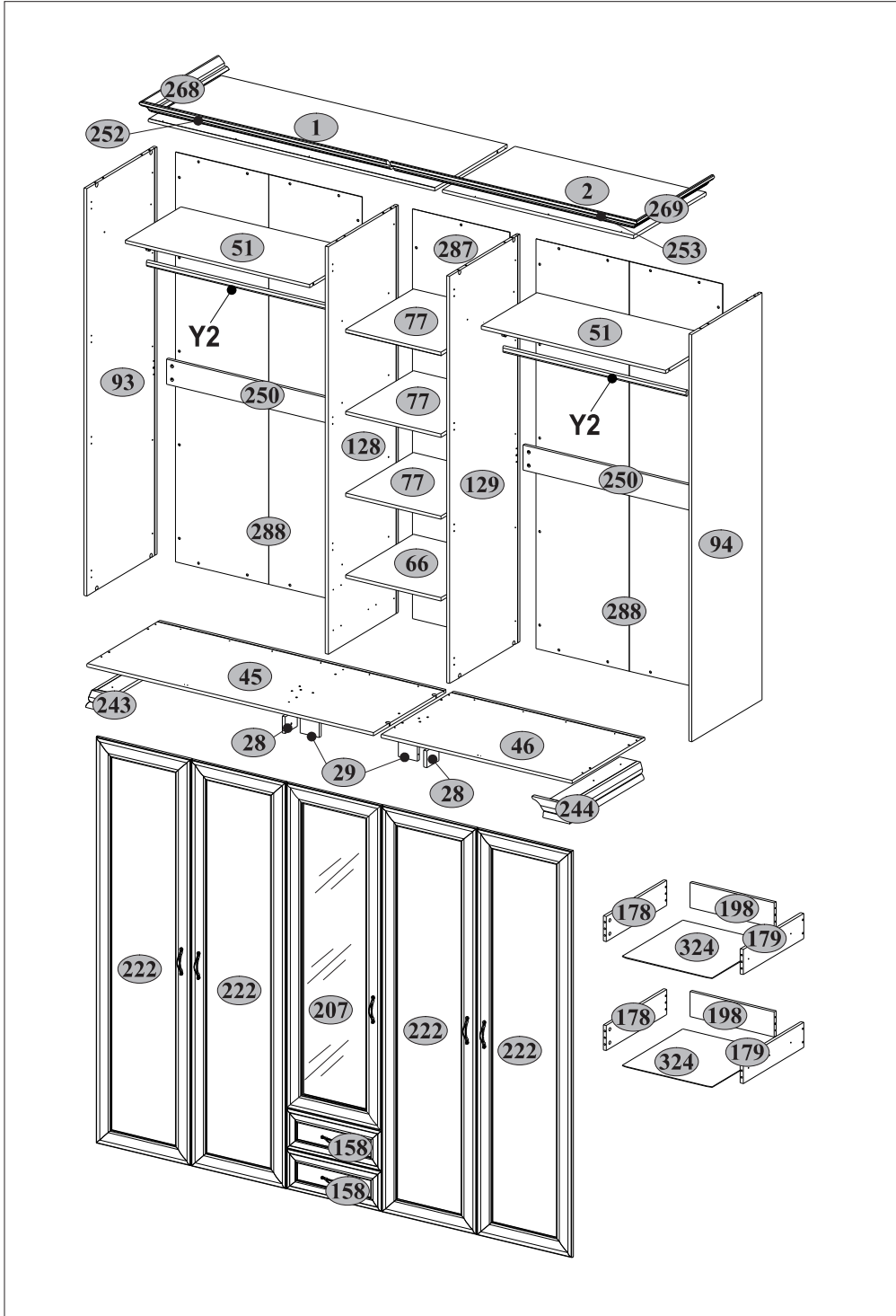



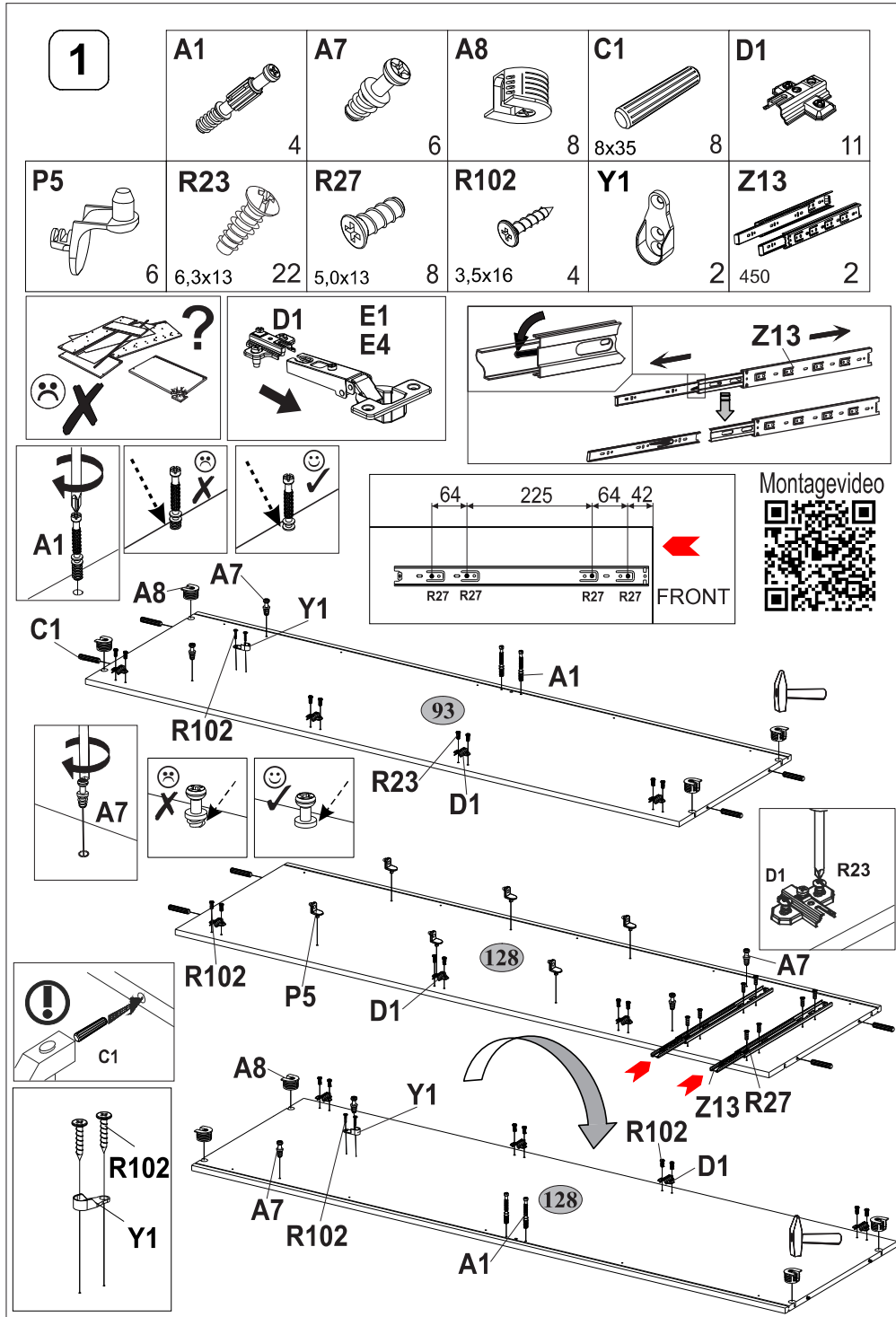

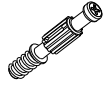

Číslo	Délka/Dĺžka	Šířka/Šírka	Tloušťka/Hrúbka	Počet	Paleta
1	1504	600	16	1	3/8
2	1004	600	16	1	3/8
28	100	80	16	2	3/8
29	100	80	16	2	3/8
45	1504	600	16	1	3/8
46	1004	600	16	1	1/8
51	968	460	16	2	1/8
66	500	560	16	1	1/8
77	500	560	16	3	1/8
93	1950	580	16	1	4/8
94	1950	580	16	1	4/8
128	1950	580	16	1	5/8
129	1950	580	16	1	5/8
158	496	191	19	2	3/8
178	500	120	16	2	3/8
179	500	120	16	2	3/8
198	442	120	16	2	3/8
207	1556	496	19	1	7/8
222	1945	496	19	4	6/8
243	210	615	80	1	2/8
244	210	615	80	1	2/8
250	968	120	16	2	3/8
252	1295	80	19	1	8/8
253	1295	80	19	1	8/8
268	641	80	19	1	8/8
269	641	80	19	1	8/8
287	1962	508	2,5	1	4/8
288	1962	978	2,5	2	5/8
324	472	505	2,5	2	1/8
Y2	962			2	1/8





	<b>A1</b>  16	<b>A2</b>  16	<b>A7</b>  32	<b>A8</b>  32	mm 	
	<b>B5</b>  10x50 3	<b>C1</b>  8x35 28	<b>D1</b>  19	<b>E1</b>  16		
	<b>E4</b>  3	<b>H18</b>  7	<b>I</b>  1	<b>M1</b>  M4x12 4		
	<b>M12</b>  M4x25 10	<b>N1</b>  14	<b>P5</b>  12	<b>Q</b>  10		
	<b>Q4</b>  4	<b>R3</b>  3x20 24	<b>R10</b>  4x30 6	<b>R23</b>  6,3x13 38		
	<b>R24</b>  7x50 18	<b>R27</b>  5,0x13 82	<b>R30</b>  2,9x9,5 8	<b>R39</b>  3,5x25 10		
	<b>R102</b>  3,5x16 60	<b>S5</b>  16	<b>S8</b>  6	<b>S12</b>  54		
	<b>U</b>  3	<b>U6</b>  1	<b>U8</b>  120° 2	<b>Y1</b>  4		
	<b>Z13</b>  450 2					



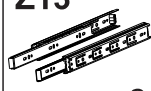

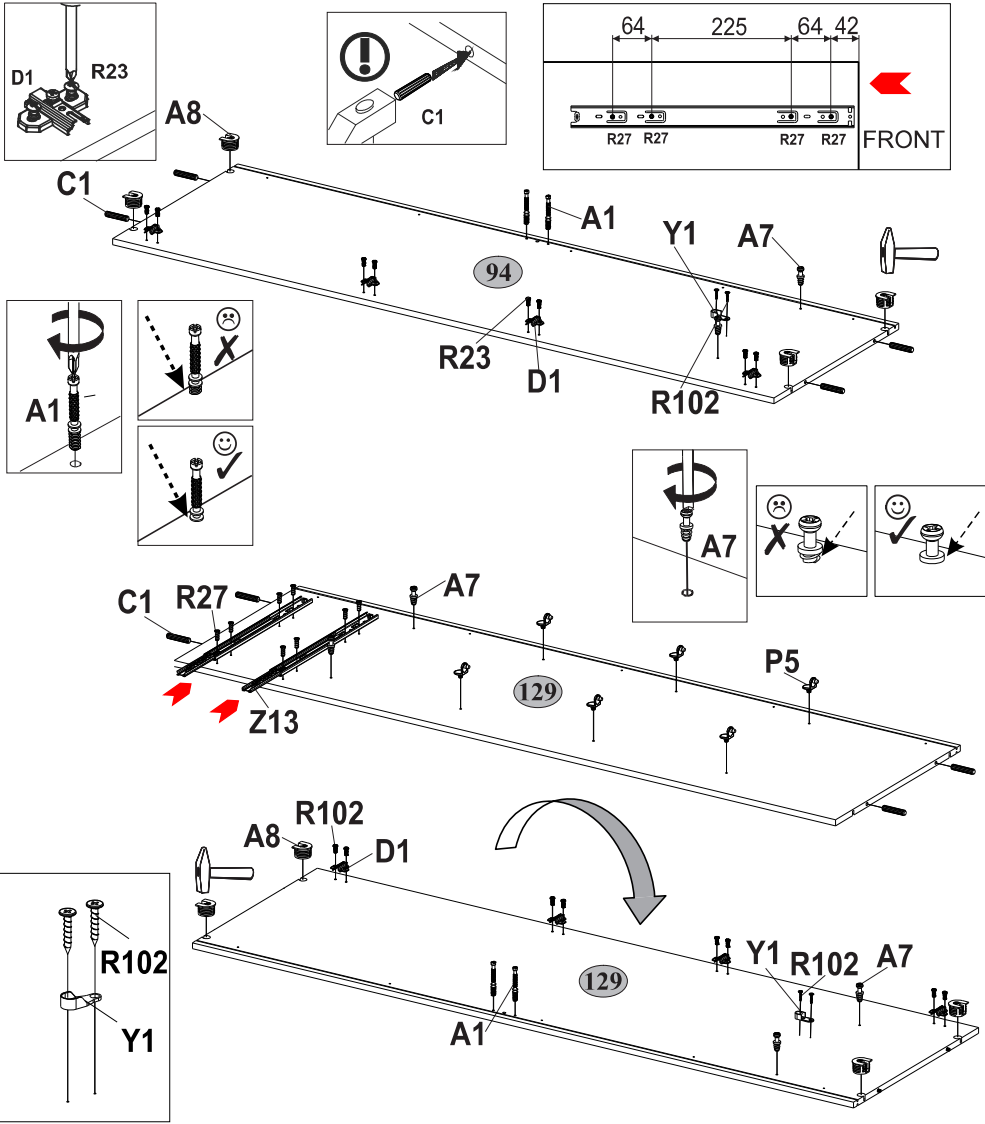
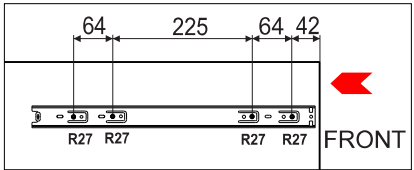
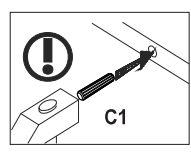
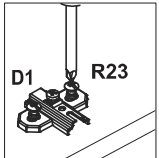

2

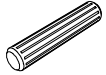
<b>A1</b>  4	<b>A7</b>  6	<b>A8</b>  8	<b>C1</b>  8x35 8	<b>D1</b>  8	
<b>P5</b>  6	<b>R23</b>  6,3x13 16	<b>R27</b>  5,0x13 8	<b>R102</b>  3,5x16 4	<b>Y1</b>  2	<b>Z13</b>  450 2

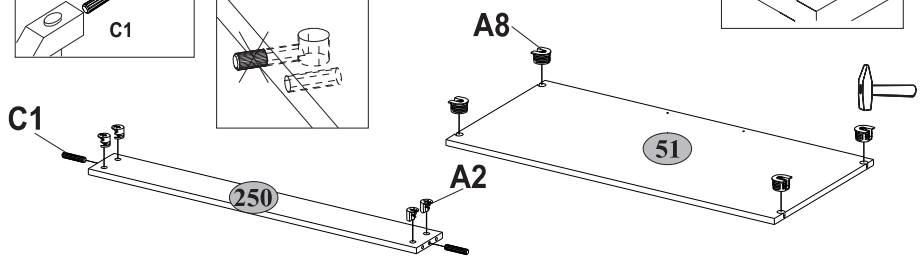
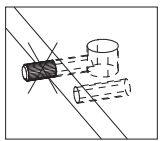
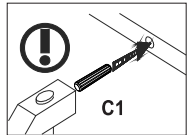
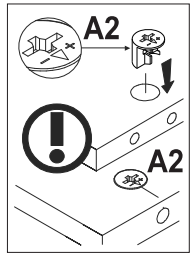

<b>3</b> x2	<b>A2</b>	<b>A8</b>	<b>C1</b>
			
	8	8	8x35 4

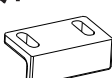

<b>4</b>	<b>A7</b>	<b>A8</b>	<b>Q4</b>	<b>R102</b>
				
	10	6	2	3,5x16 4

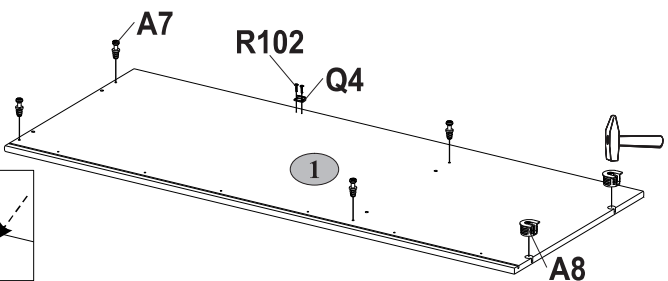
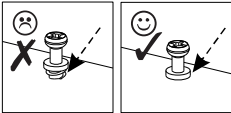
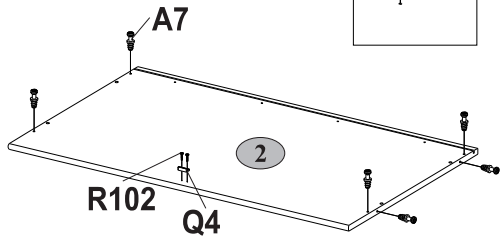
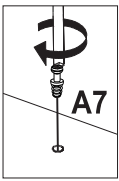
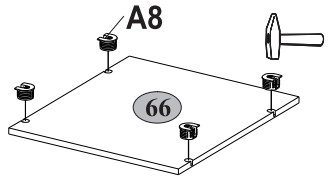
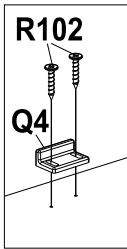

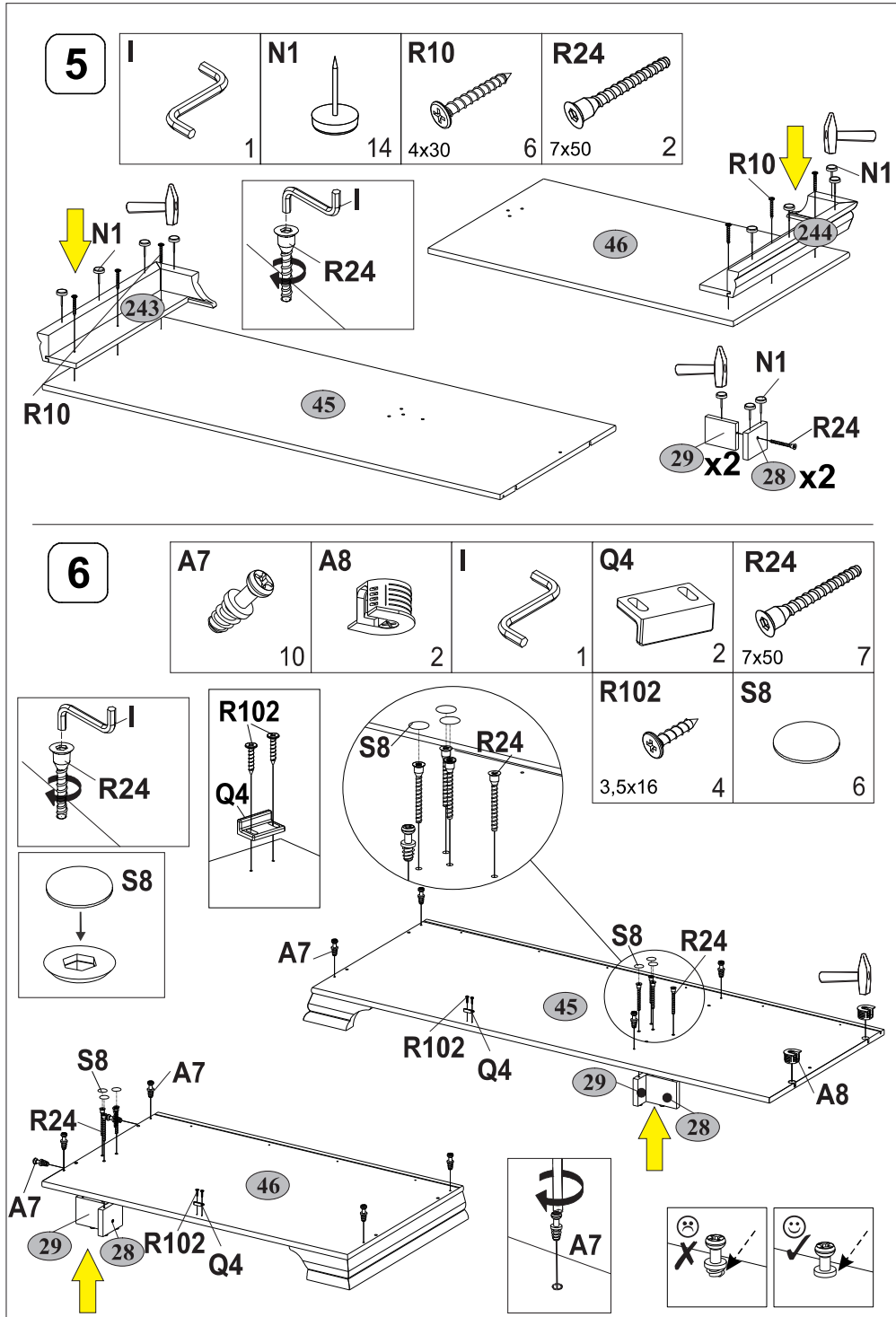



7

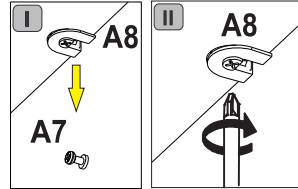
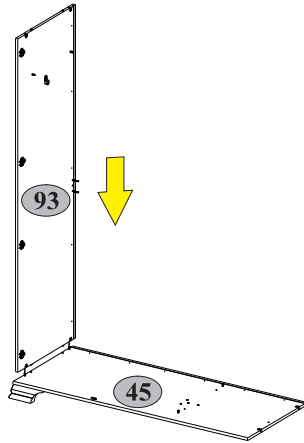

8

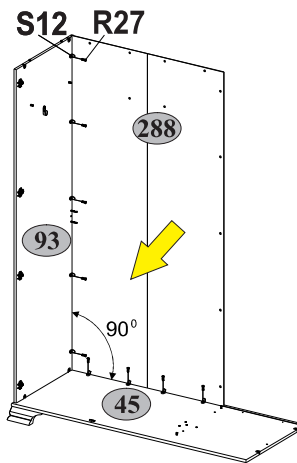
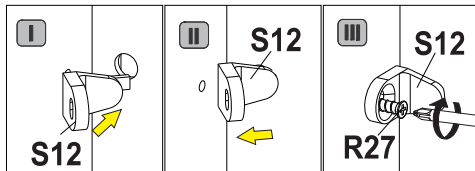
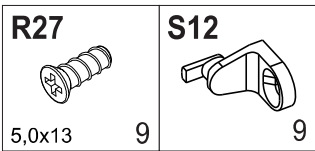

9

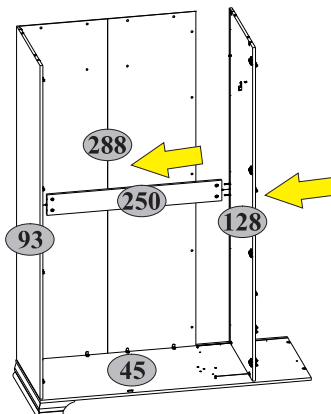
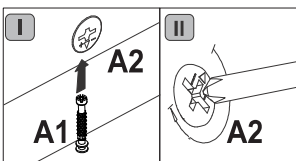
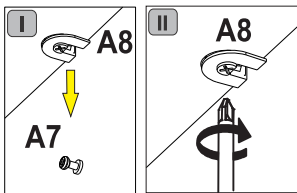

10

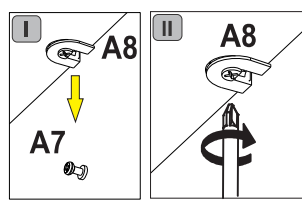
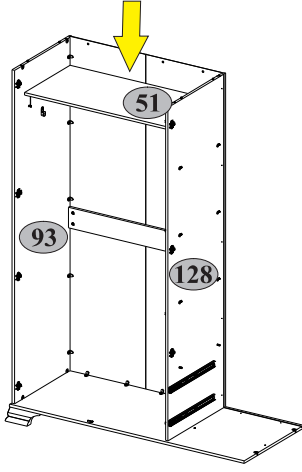

11

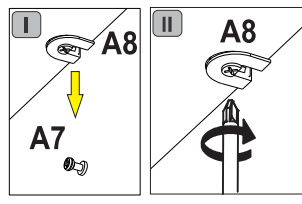
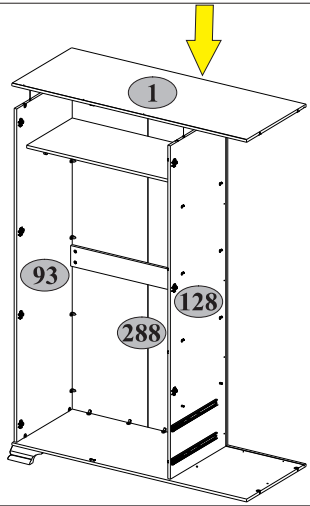

12

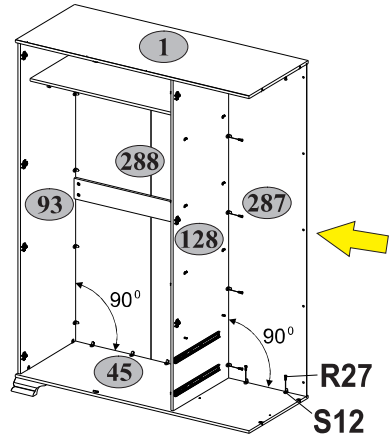
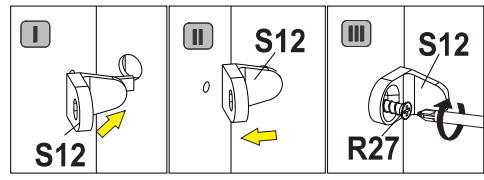
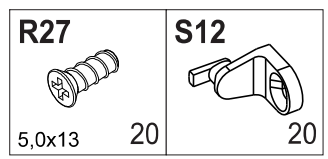

13

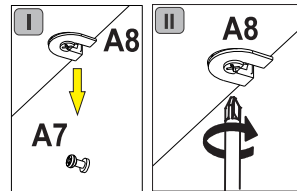
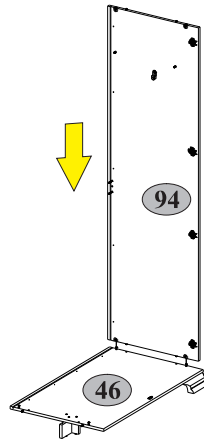

14

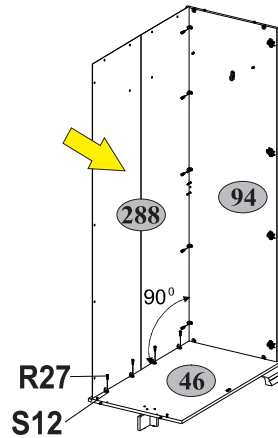
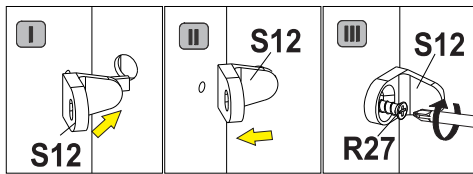
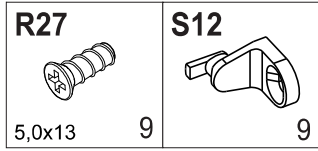

15

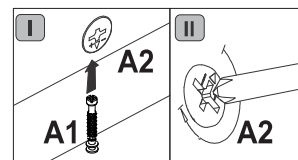
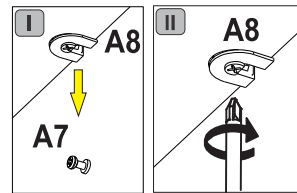
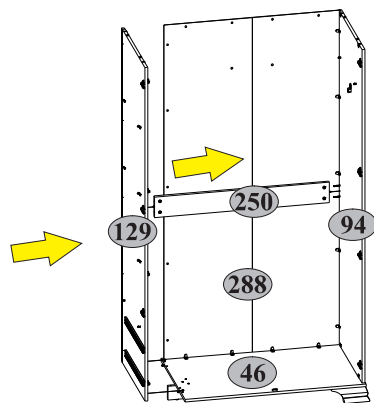

16

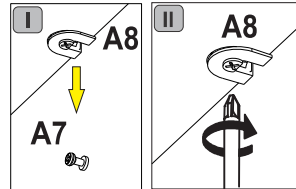
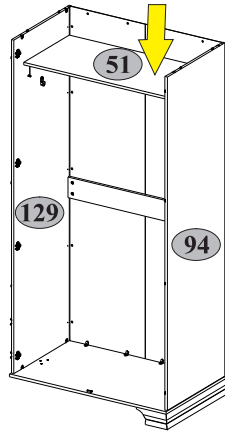

17

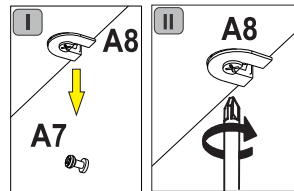
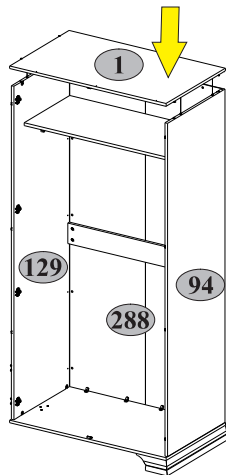



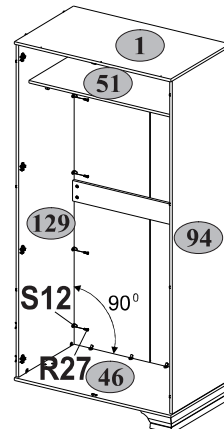
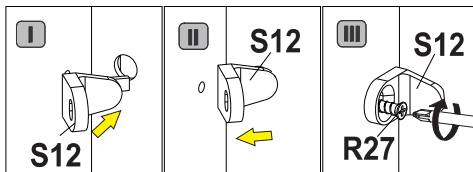
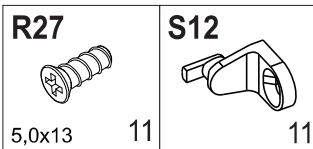

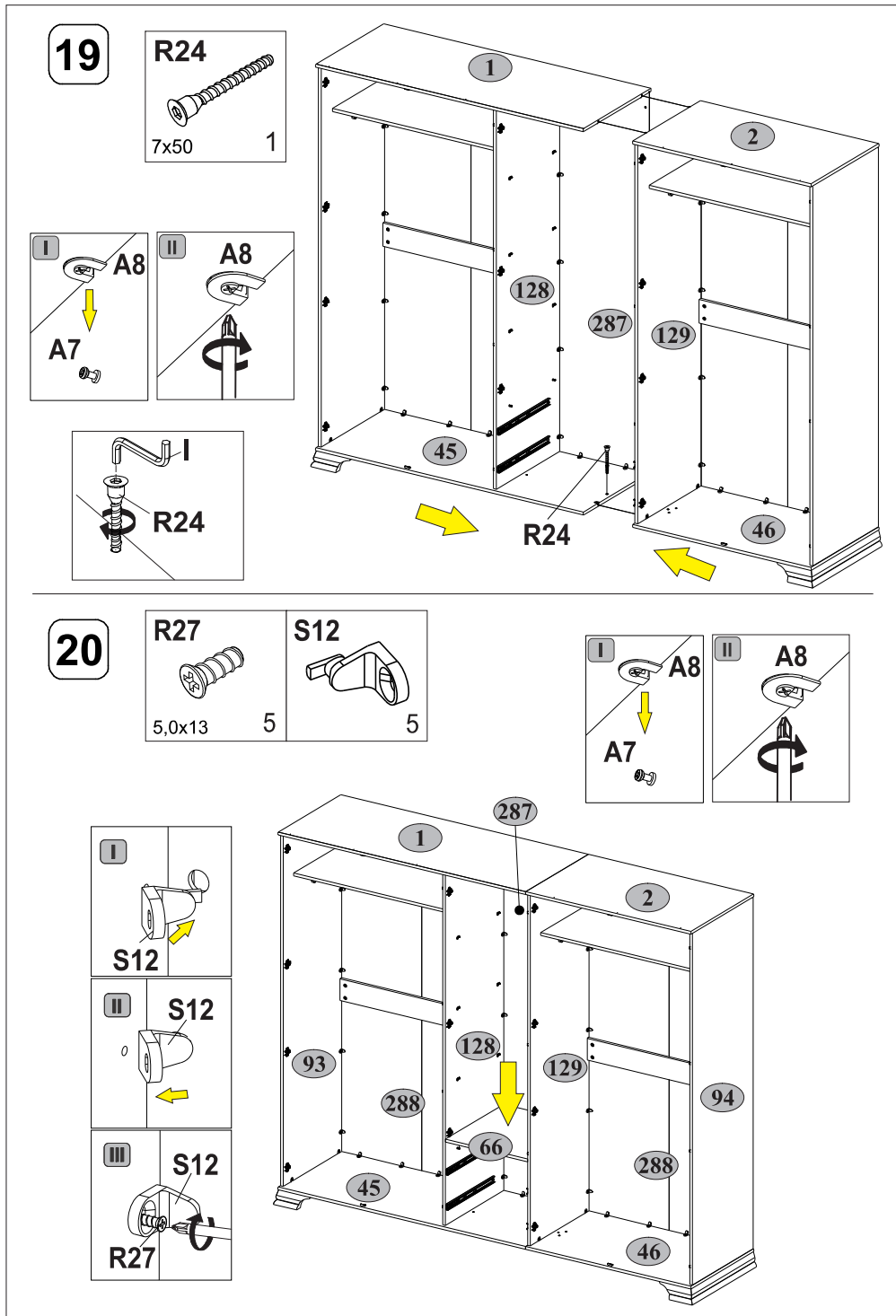



18

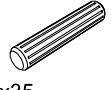



**21**  
x2

<b>A1</b>  8	<b>A2</b>  8	<b>C1</b>  8x35 8	<b>H18</b>  2	<b>M1</b>  M4x12 4
<b>R24</b>  7x50 8	<b>R27</b>  5,0x13 12	<b>S5</b>  8	<b>Z13</b>  450 2	

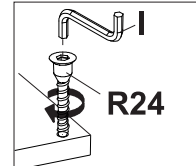
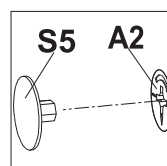
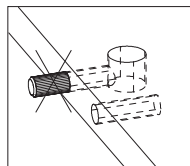
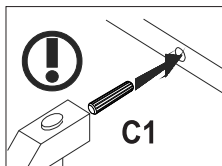
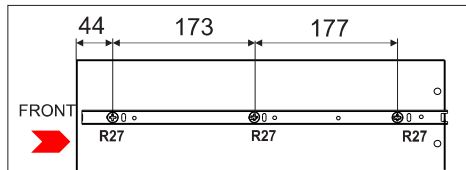
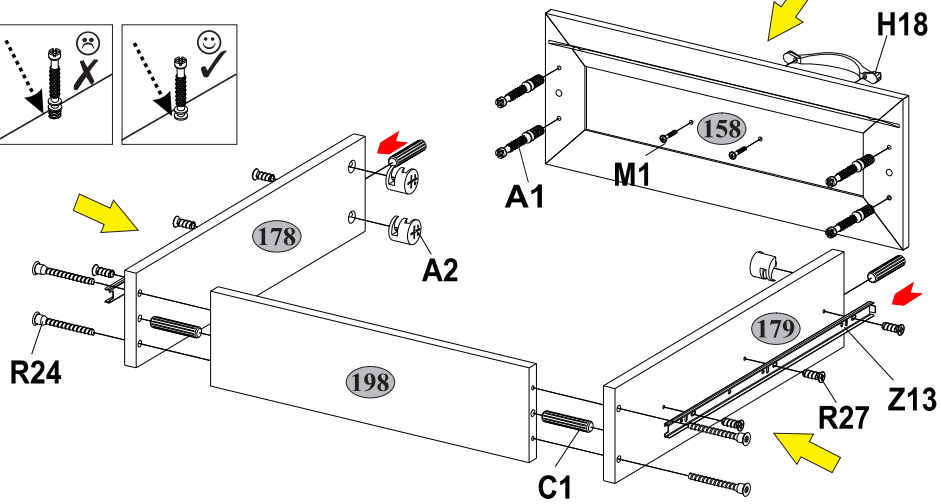
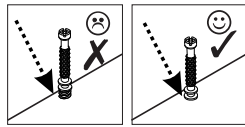
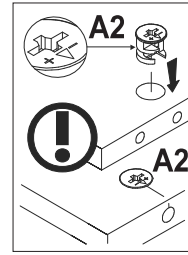
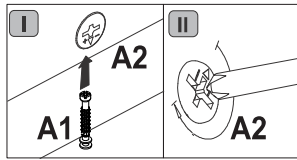
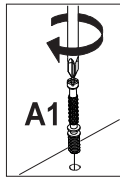

**22** R3  
x2 3x20 24

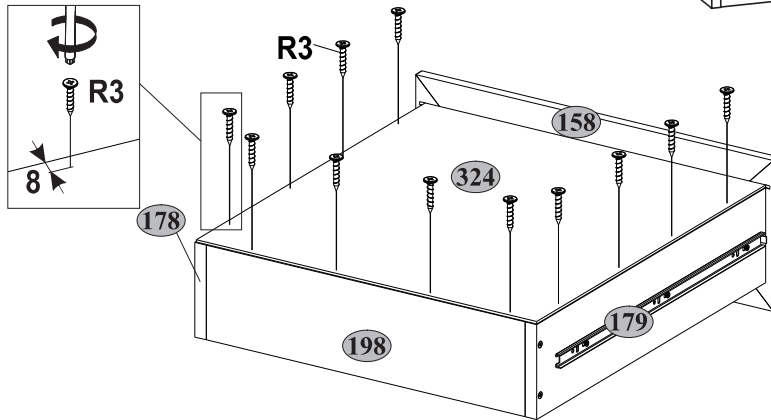
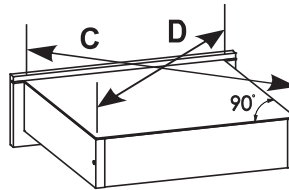
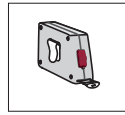

**23** E1 16 E4 3 H18 5 M12 10 R102 38  
M4x25 10 3,5x16 38

