

BELLUNO

WITRYNA 2D

PL015



(D) Montageanleitung

(FR) Notice de montage

(NL) Handleiding voor de montage

(CZ) Montážní návod

(HU) Szerelési útmutató

(TR) Montaj talimatı

(GB) Assembly instructions

(IT) Istruzioni di montaggio

(PL) Instrukcja montażu

(SK) Návod na montáž

(RO) Instrucțiuni de montaj

(RU) ИНСТРУКЦИЯ ПО МОНТАЖУ

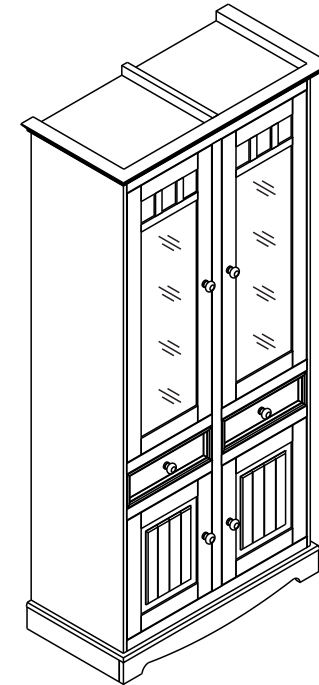

12.07.2016.

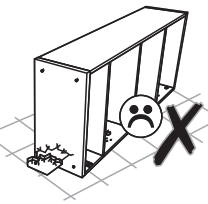
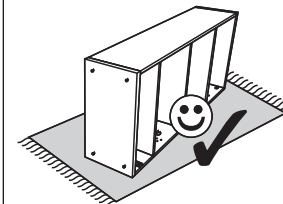
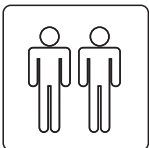
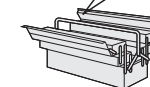
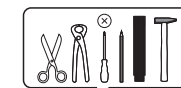
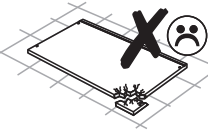
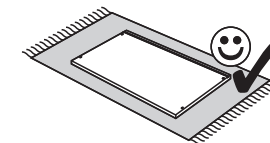

3,5 - 4

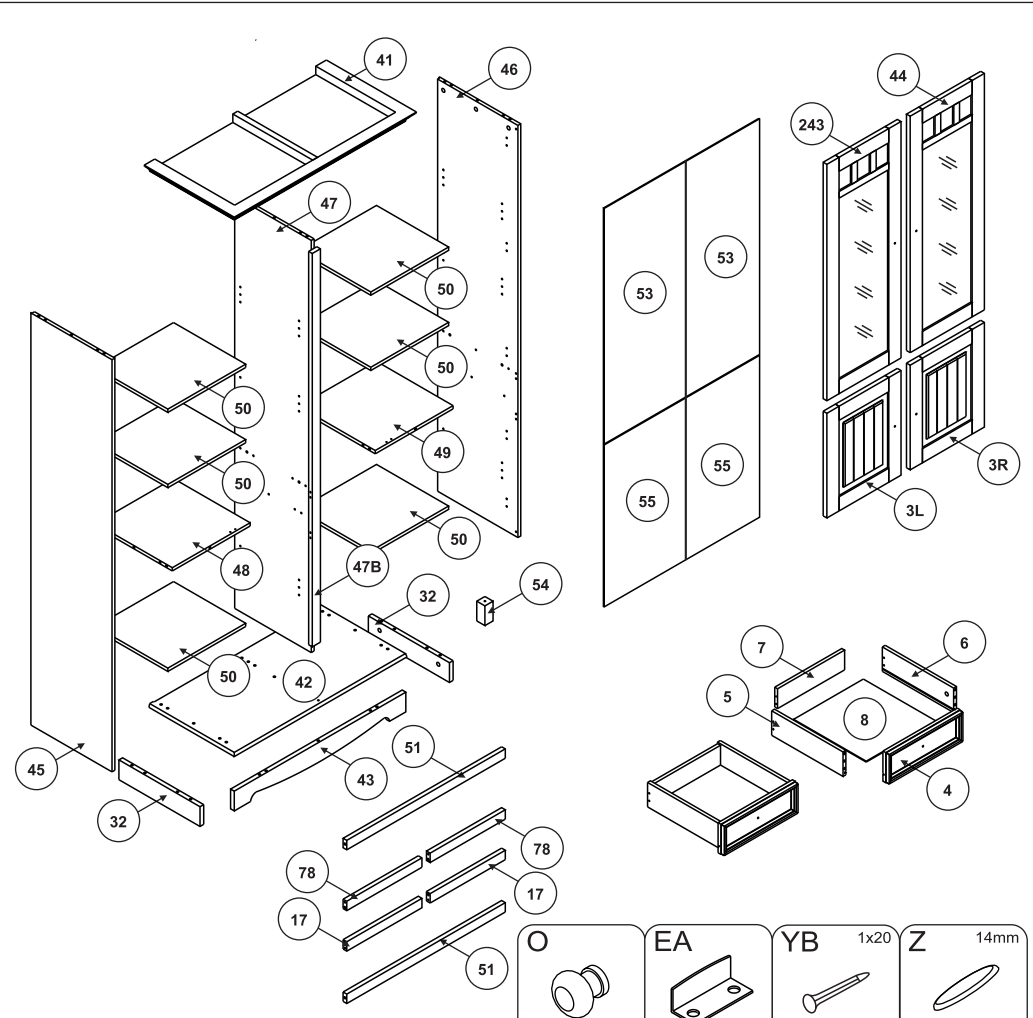

A 8x35 x26	AB 5x30 x16	B 34mm x48	C 15x10 x48	D x8	E x6	G L=350 x2	H 6x10,5 x4
M 38x27x21 x3	MA x16	N 3x10 x4	NA 3,5x16 x25	NB 3,5x35 x8	NC 3,5x30 x3	YC M4x22 x6	NE 3x13 x32
V 20,5x9 x4	VA 20,5x3 x4	HA 6x28 x4	PA x10	RA x10	W 4mm x1	Y 5mm x24	YA 7x50 x10

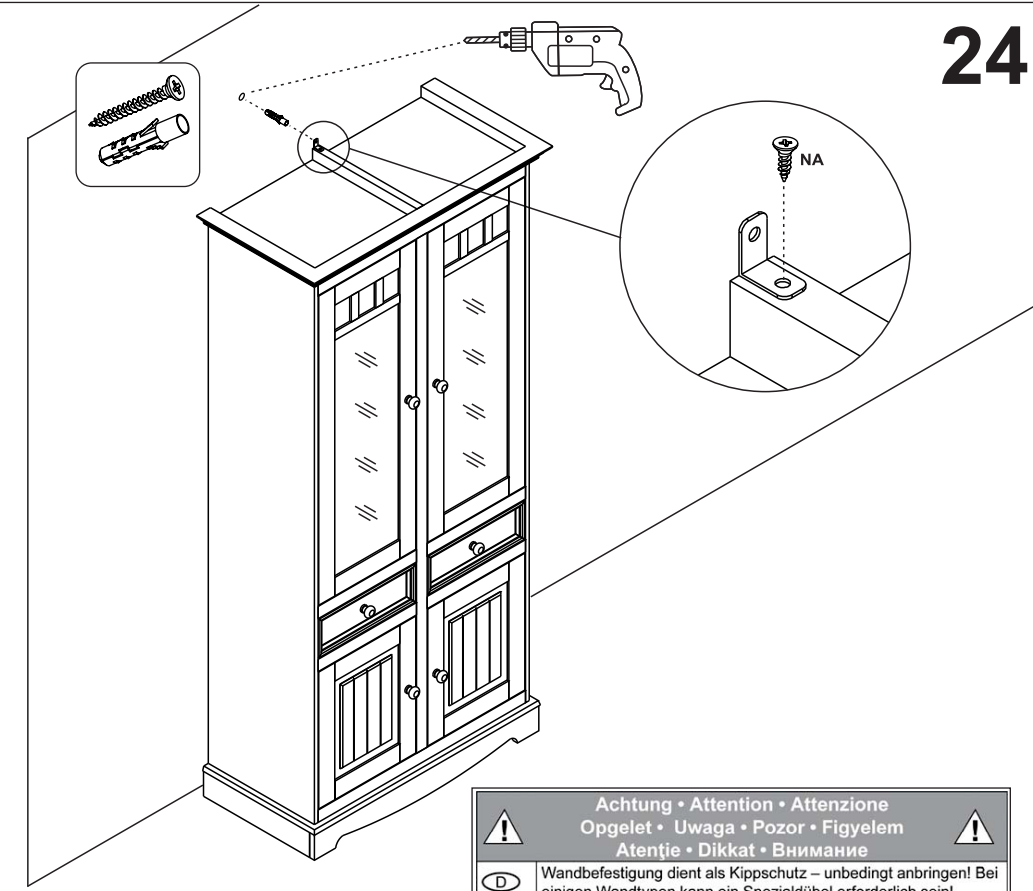
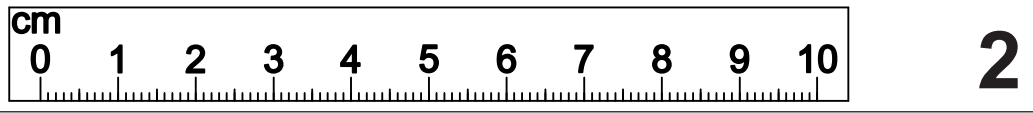

⚠ Achtung • Attention • Attenzione Opgelet • Uwaga • Pozor • Figyelem Atenție • Dikkat • Внимание ⚠	
(D)	Wandbefestigung dient als Kippschutz – unbedingt anbringen! Bei einigen Wandtypen kann ein Spezialdübel erforderlich sein!
(GB)	The wall fastening serves to prevent tipping – be absolutely sure to mount it! For certain wall types, a special wall plug may be necessary!
(FR)	La fixation murale sert de protection contre le basculement – à installer impérativement ! Pour certains types de murs il faut des chevilles spéciales !
(IT)	Il fissaggio alla parete serve da protezione anti-ribaltamento – attaccarla assolutamente! Per alcune strutture di parete può essere necessario un tassello speciale!
(NL)	Bevestiging aan de muur dient als kantelbescherming – zeker en vast bevestigen! Bij enkele muurtypen is een speciale plug mischien vereist!
(PL)	Mocowanie do ściany jest jednocześnie zabezpieczeniem przed przewróceniem – koniecznie zamontować! Do niektórych rodzajów ścian koniecznie zastosować specjalne kołki mocujące.
(CZ)	Montáž na stěnu slouží jako ochrana proti převrhnutí – bezpodmienečně umístěte! U některých typů stěn může být zapotřebí speciální hmoždinka!
(SK)	Upevnenie na stenu slúži ako ochrana proti prevráteniu – bezpodmienečne použite! Pre niektoré druhy stien môže byť potrebná špeciálna hmoždinka!
(HU)	A terméket a falhoz kel rögzíteni, különben az felborulhat! Egyes fal típusoknál speciális tiplét kell használni!
(RO)	Sistemul de fixare la perete servește ca protecție la răsturnare – de montat obligatoriu! Pentru unele tipuri de pereți este posibil să fie necesar un diblu special!
(TR)	Duvardaki sabitleme, devrilmeye karşı bir emniyet tedbiridir ve mutlaka monte edilmelidir! Bazı duvar tiplerinde bunun için özel bir dübel gerekli olabilir!
(RU)	Обязательно установите крепление на стене во избежание опрокидывания! Для некоторых типов стен может потребоваться специальный дюбель!

M 38x27x21 x1	NA 3,5x16 x1
-------------------------	------------------------

23

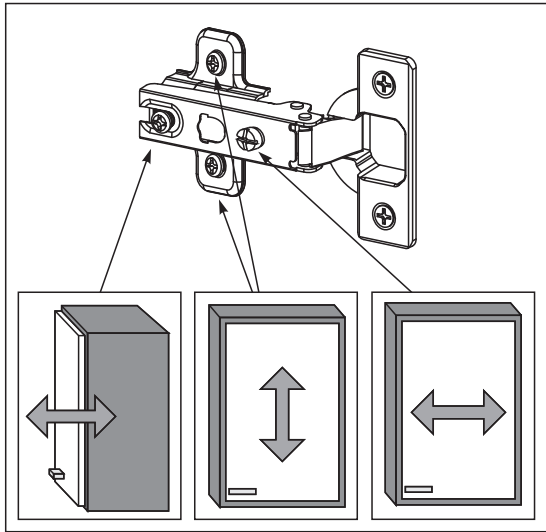
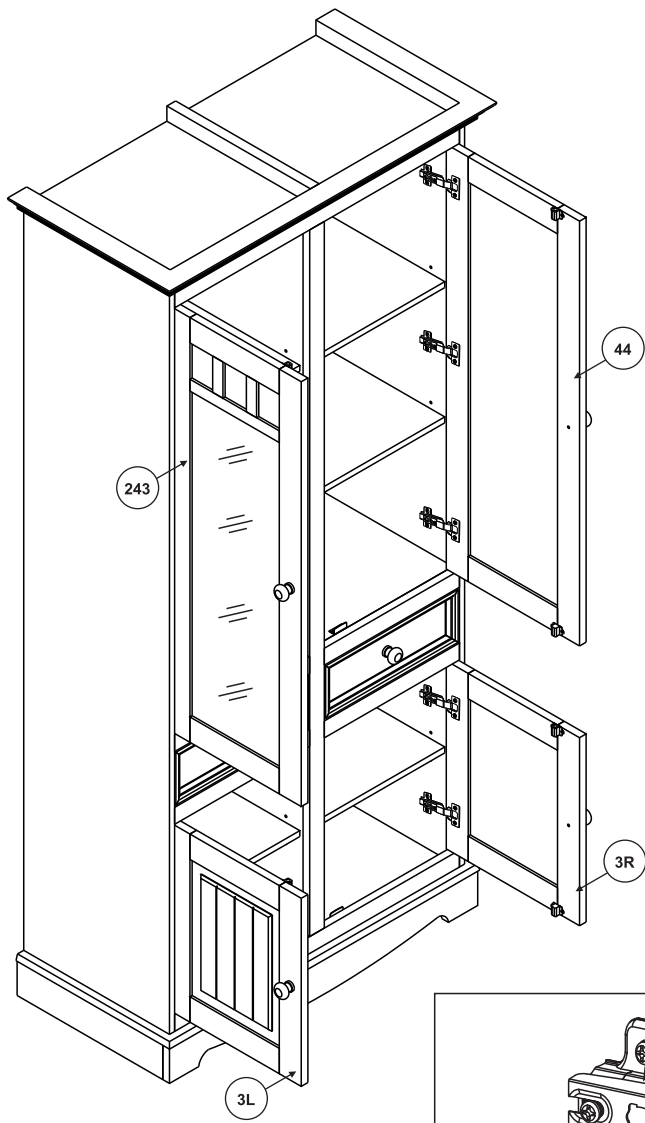

B 34mm
x9

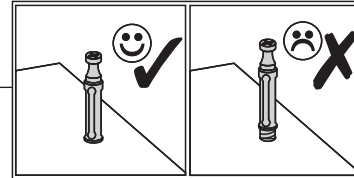
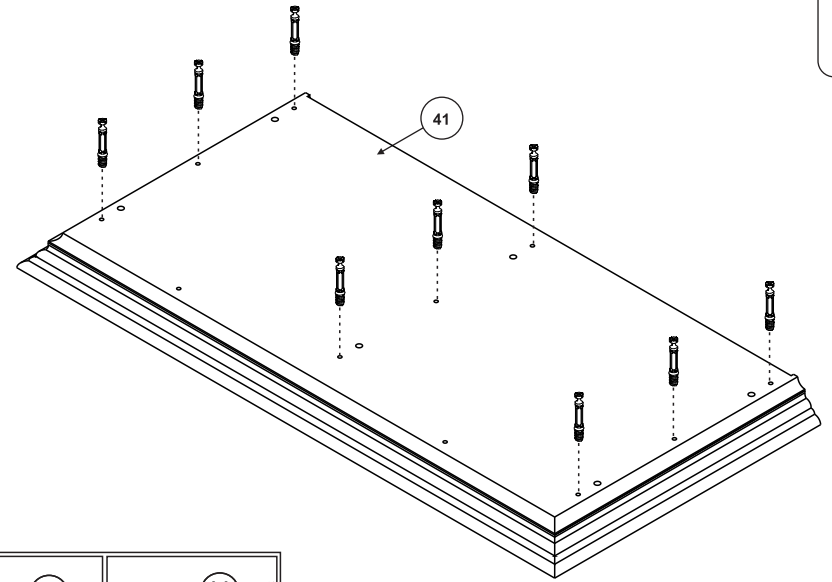

3
4

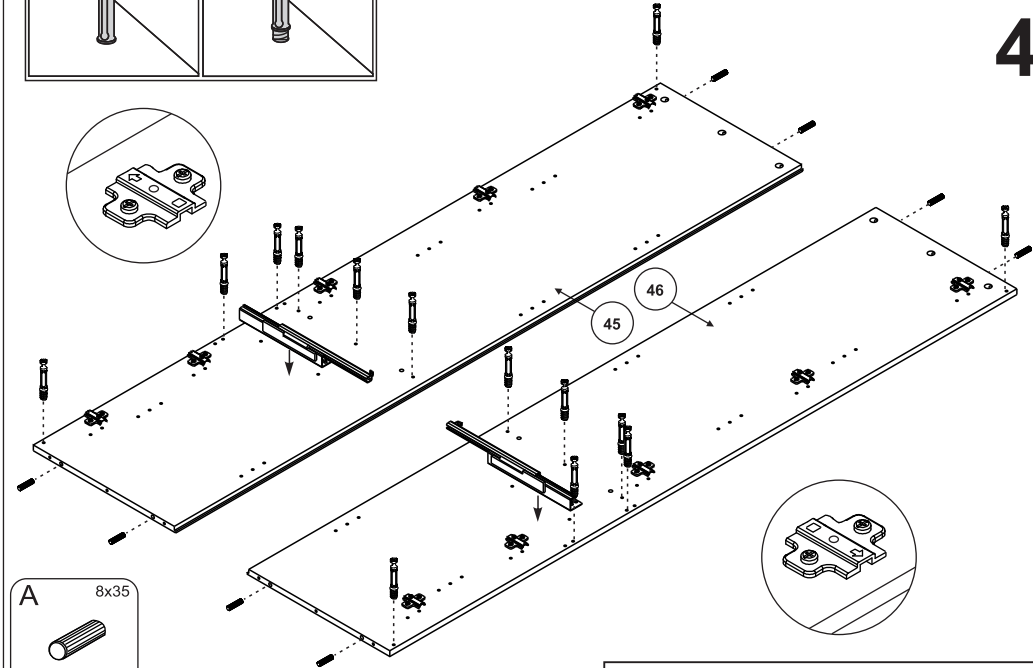

A 8x35
x8

G L=350
x1

H 6x10,5
x4

RA
x10

B 34mm
x14

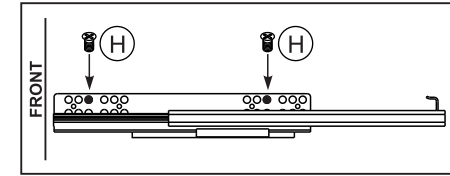

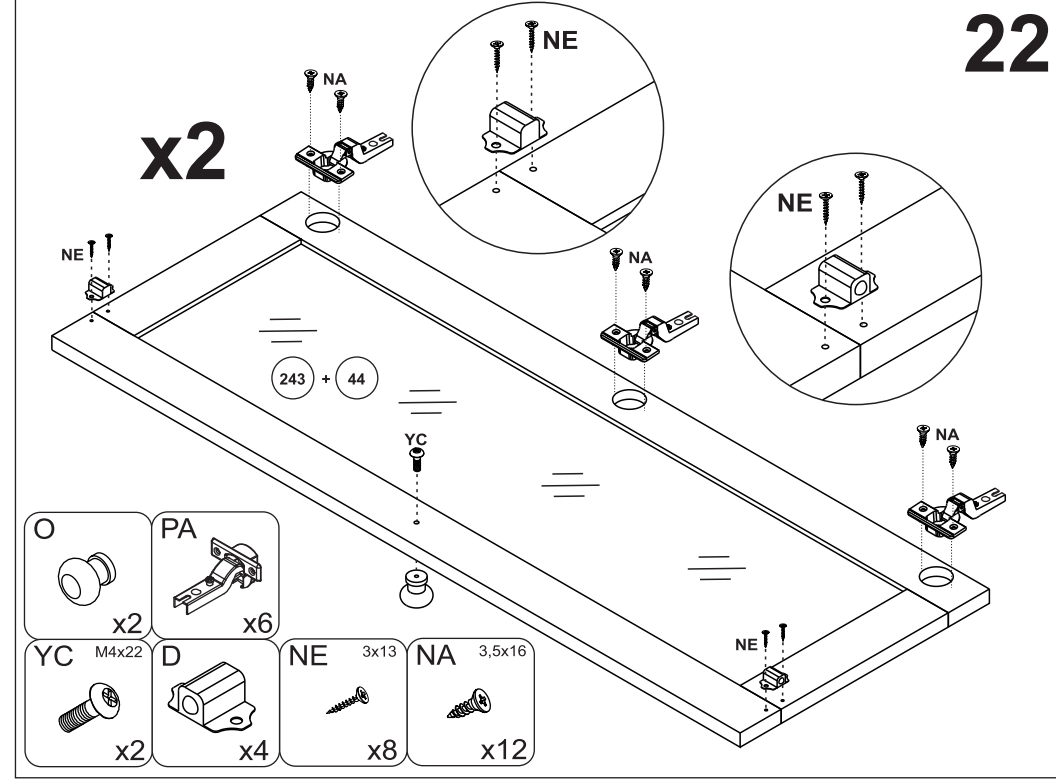
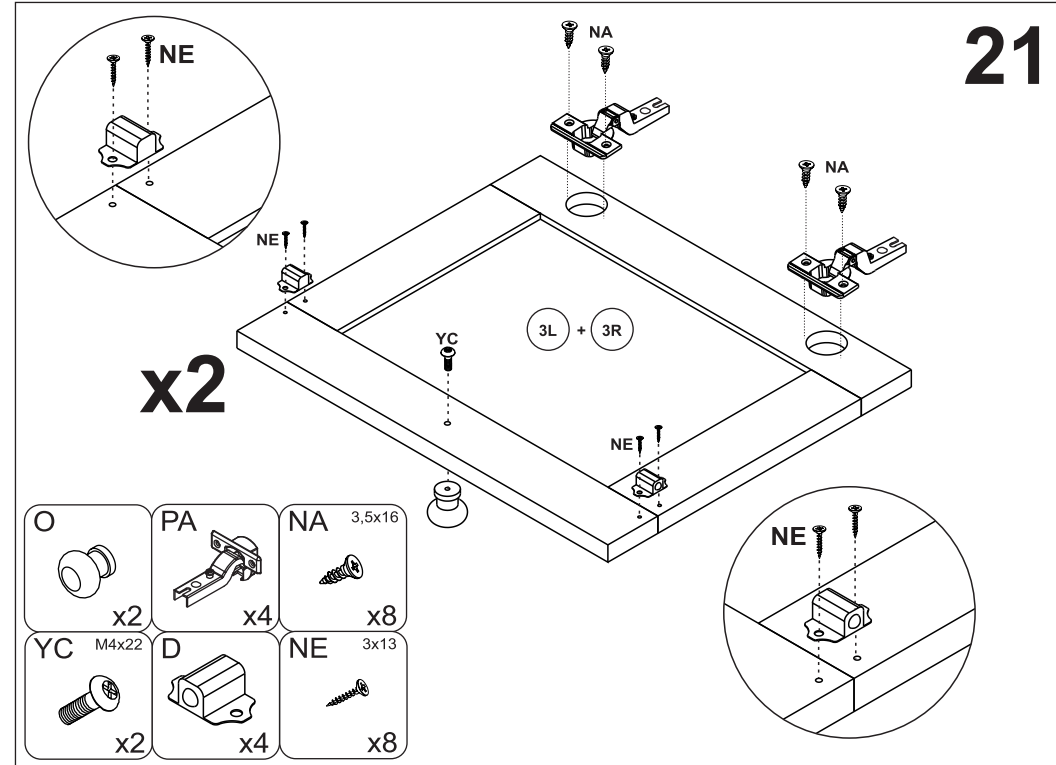
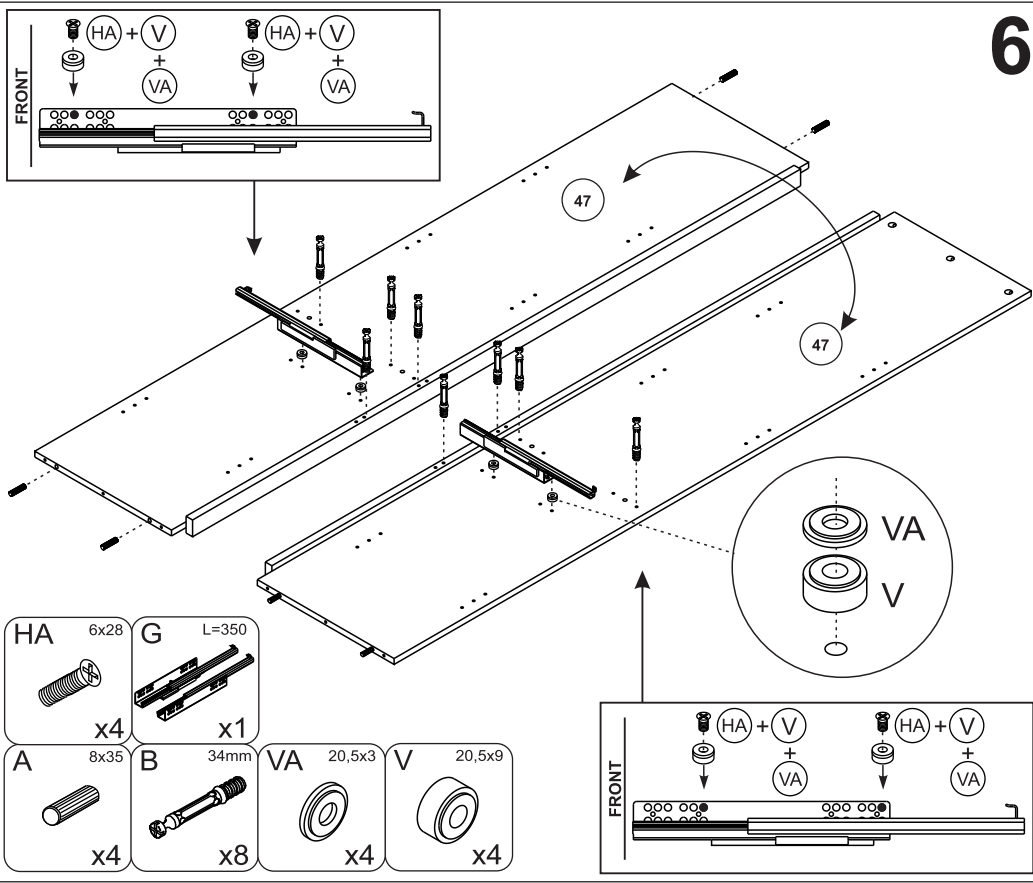
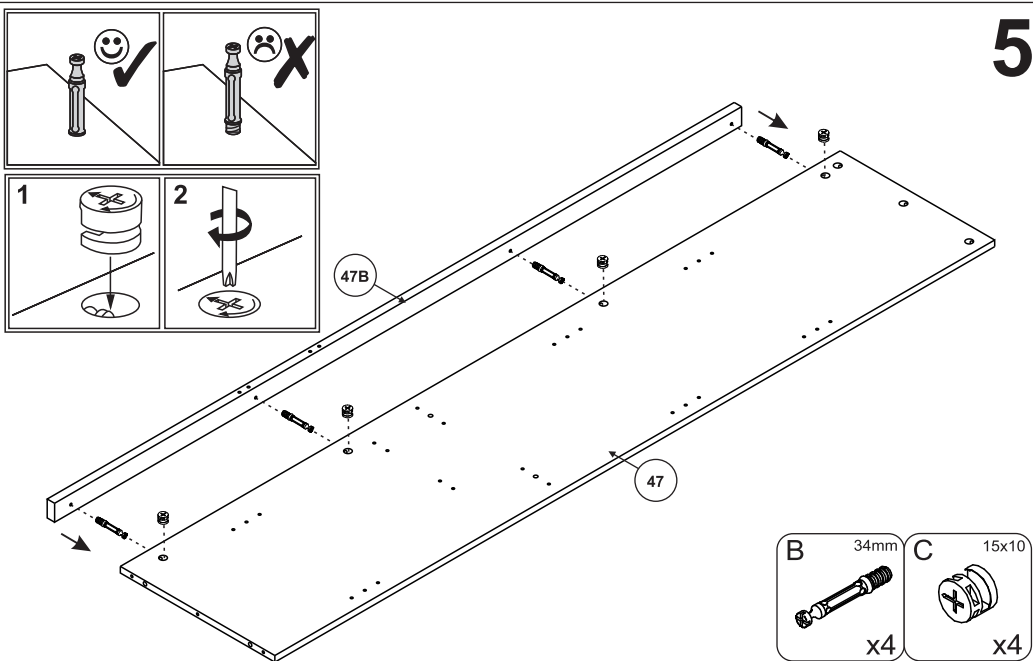

20

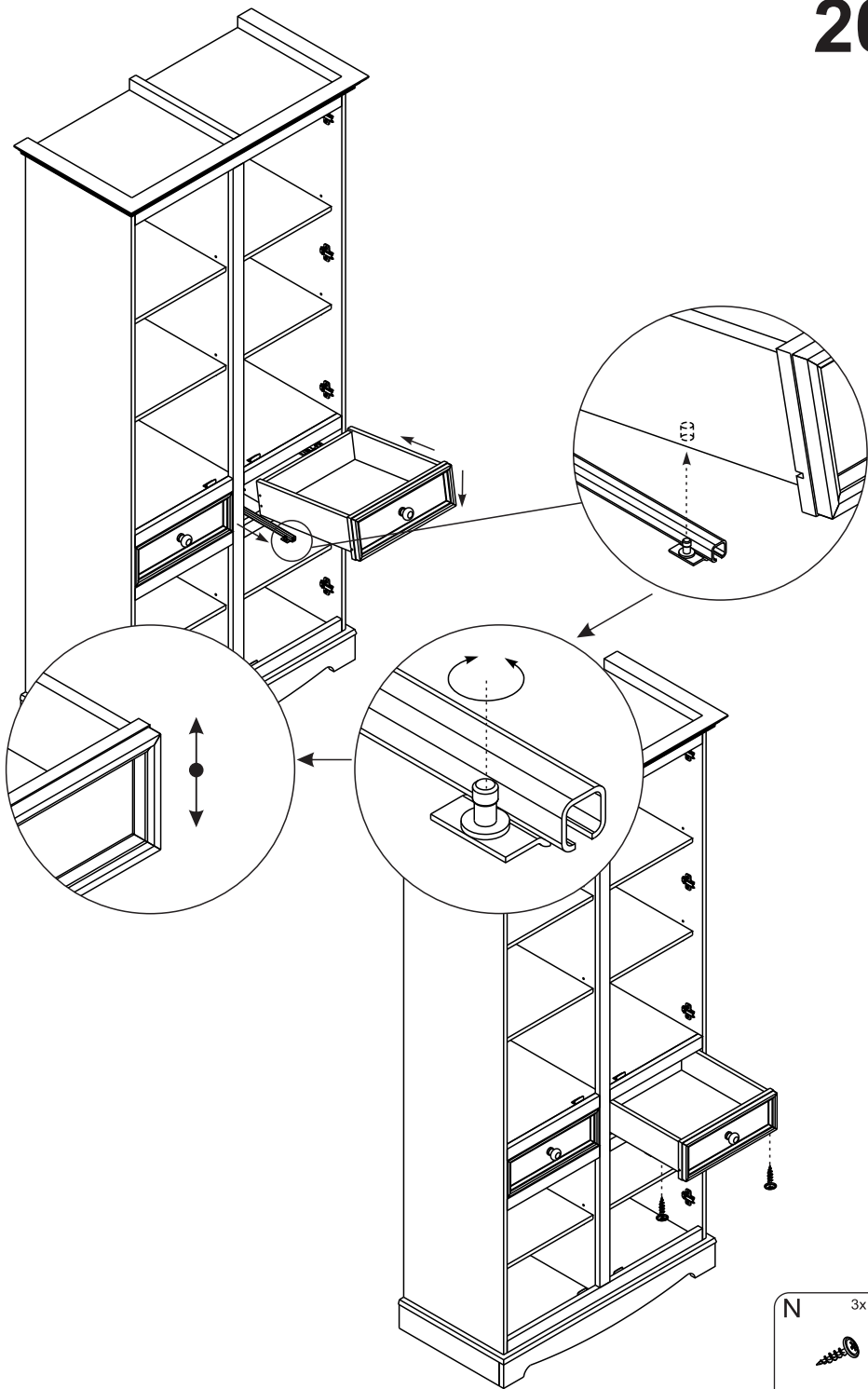

N 3x10

 x4

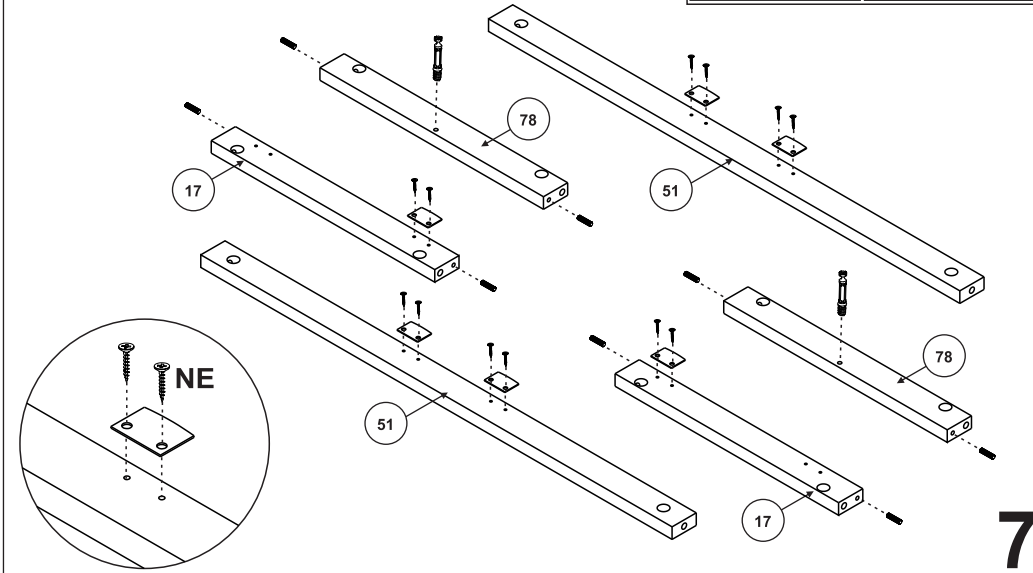
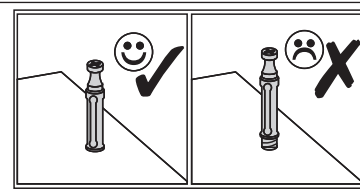
E x6 NE 3x13 x12 AB 5x30 x8 B 34mm x2

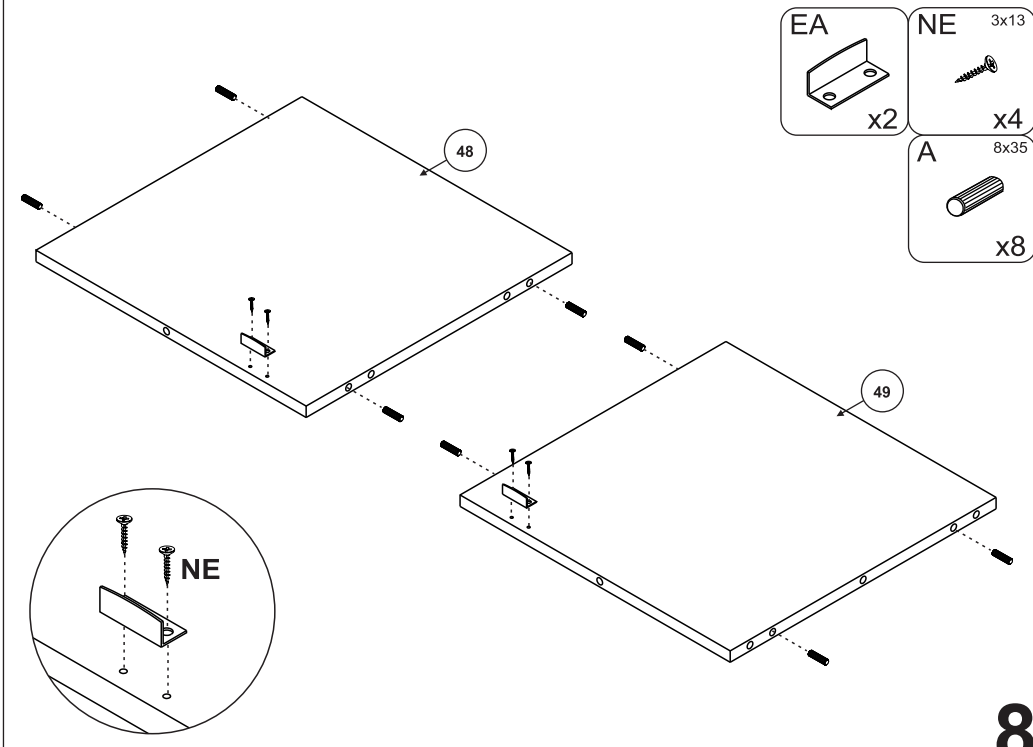

7

EA x2 NE 3x13 x4 A 8x35 x8



8

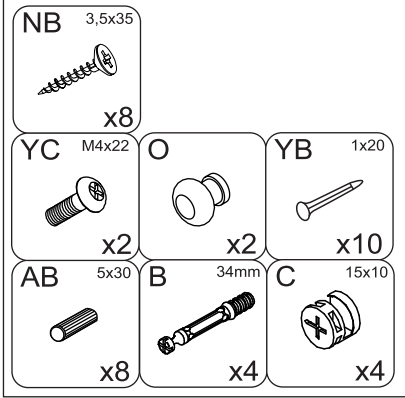
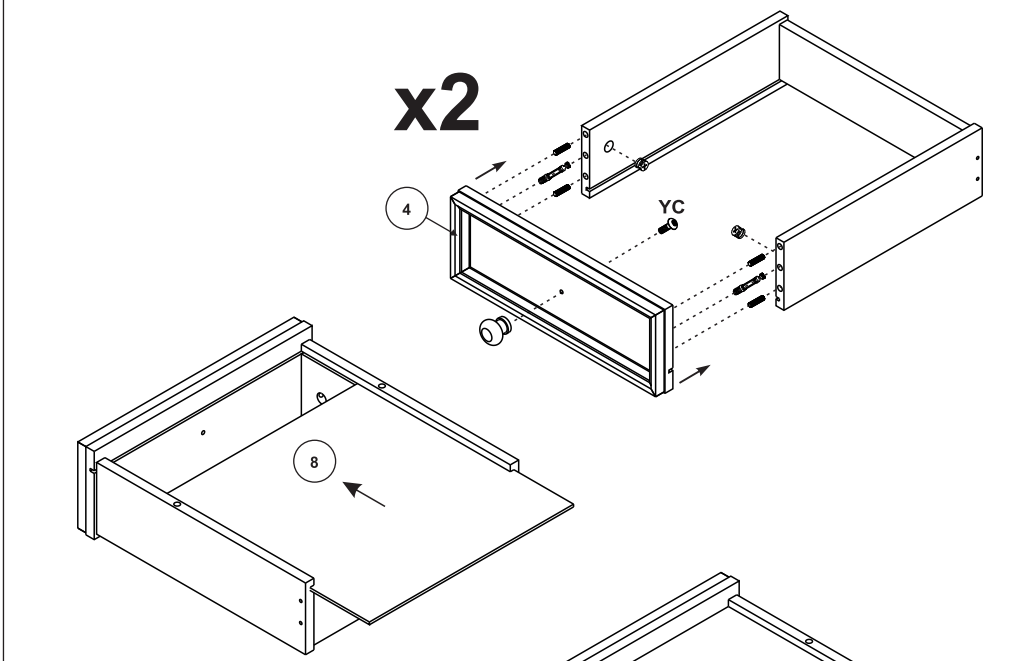
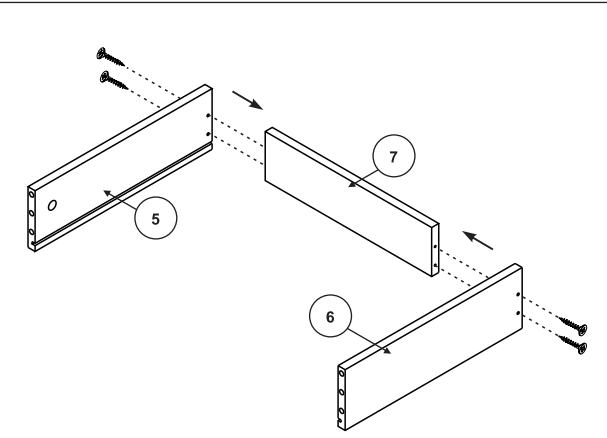
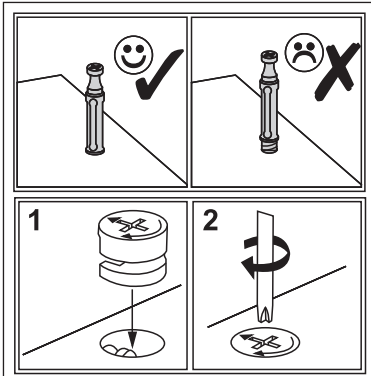
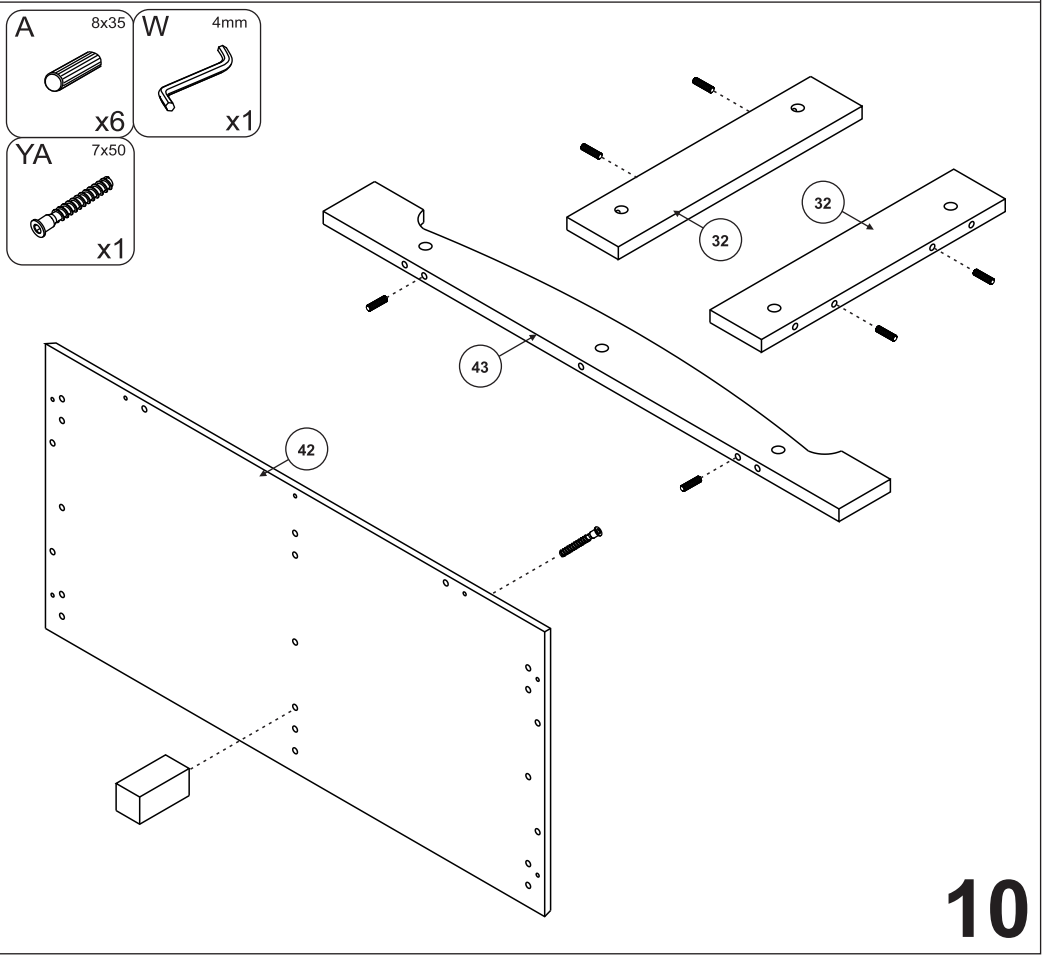
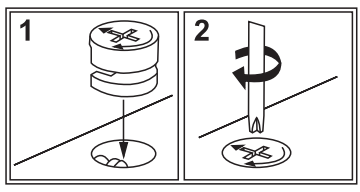
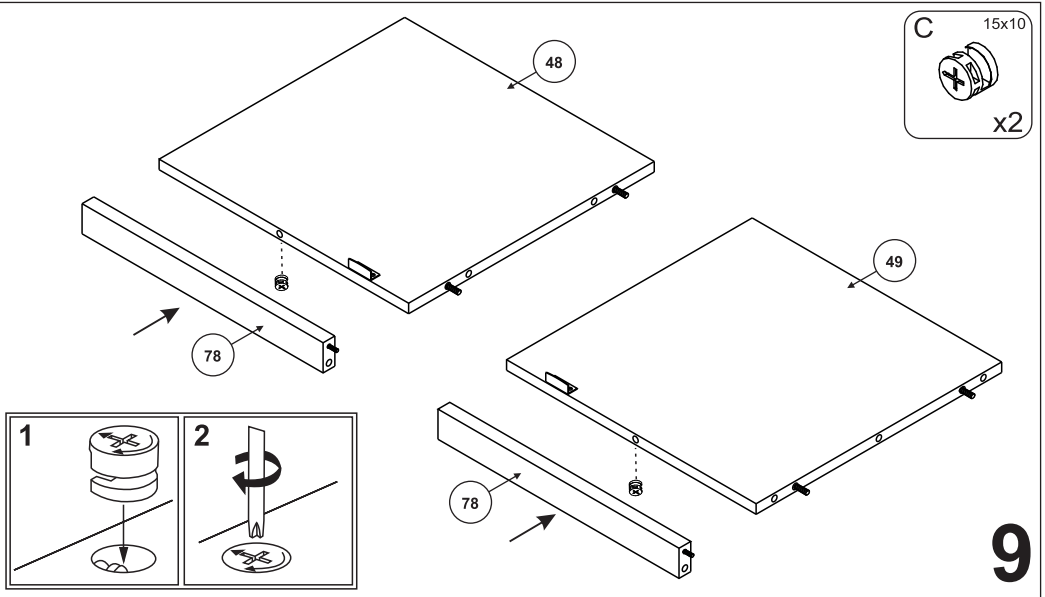

19

- YB 1x20
- MA x16

17

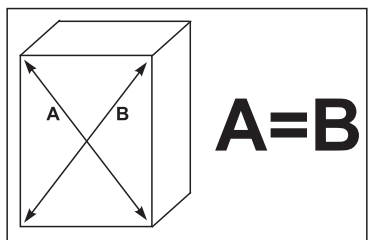
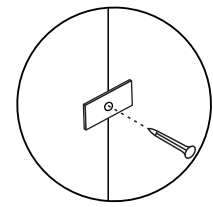
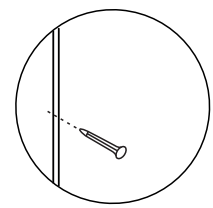
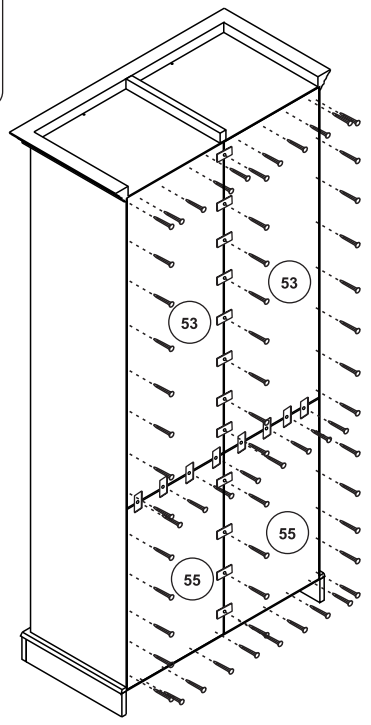

- Y 5mm
- x24

18

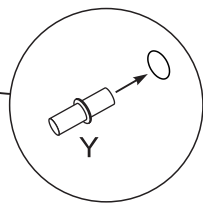
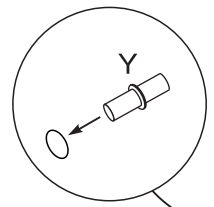
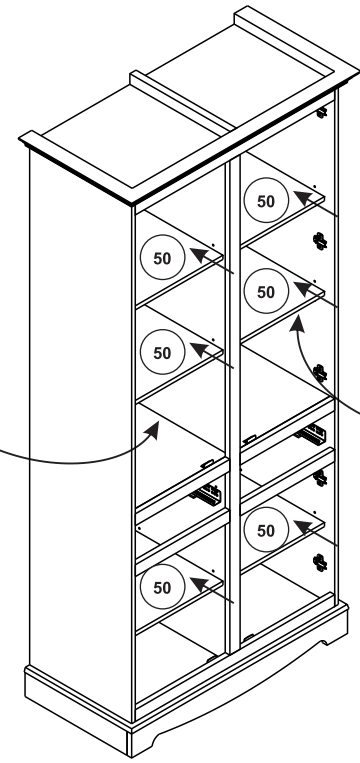

11

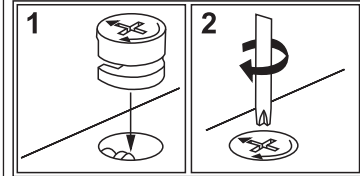
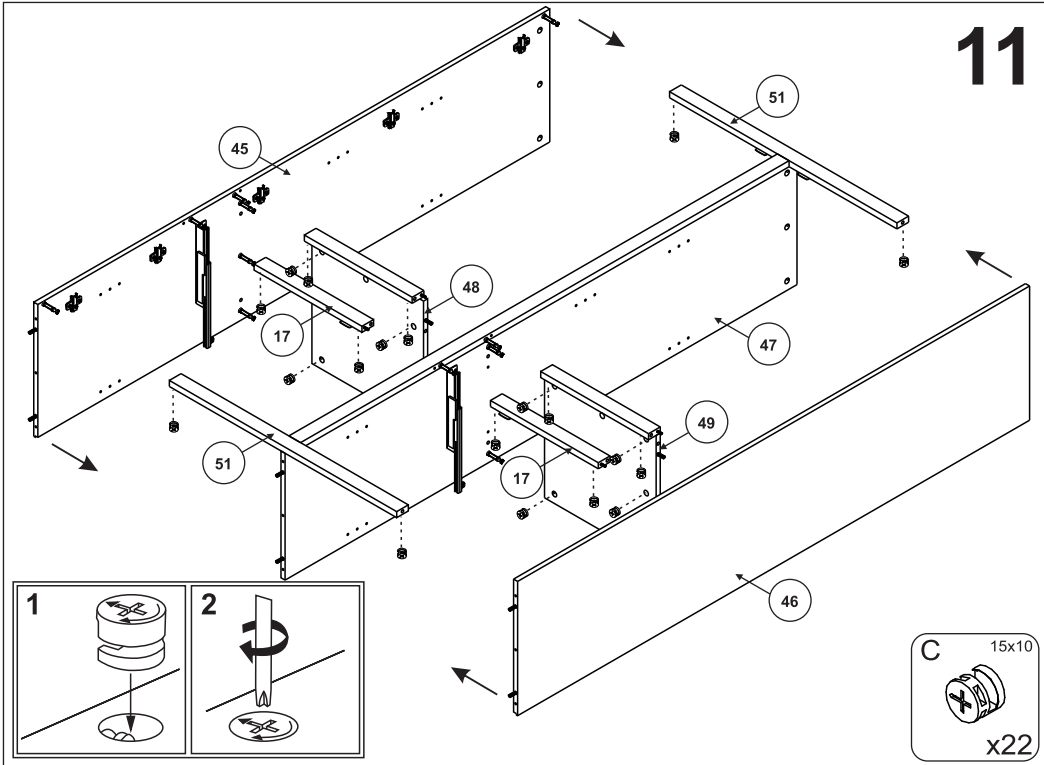

- C 15x10
- x22

- YA 7x50 x9
- W 4mm x1
- NC 3,5x30 x1

12

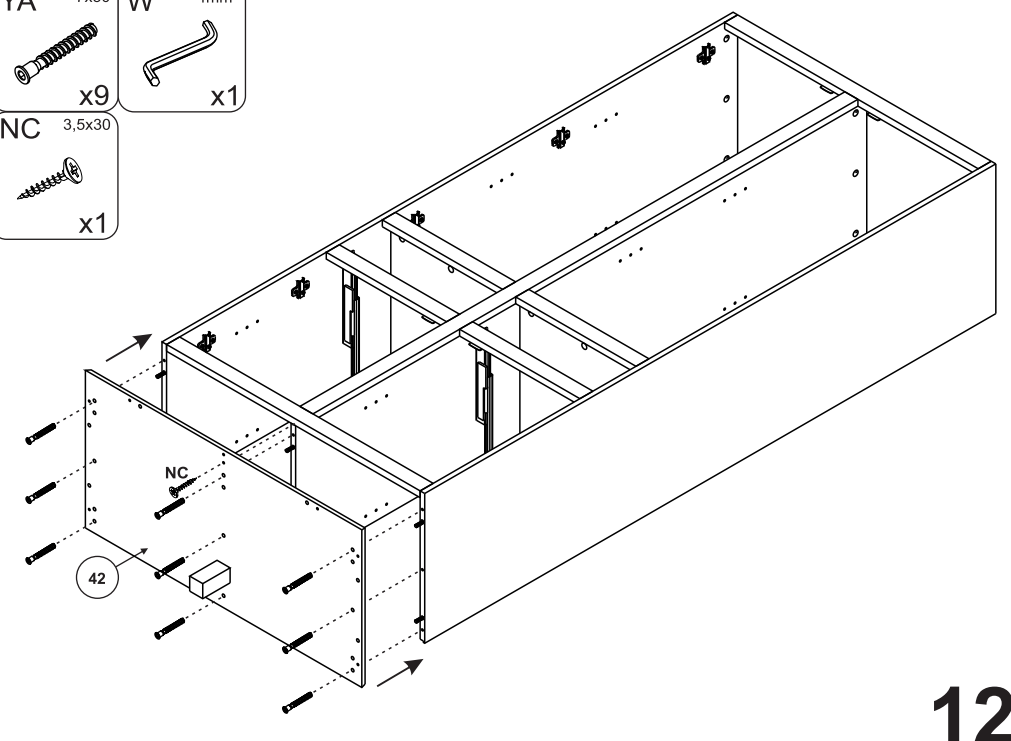

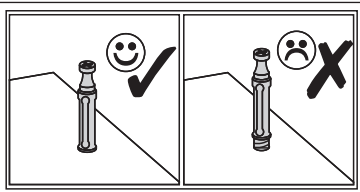

13

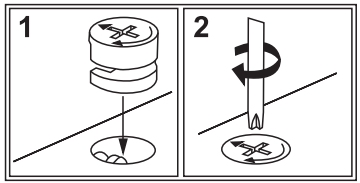
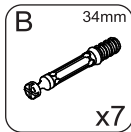
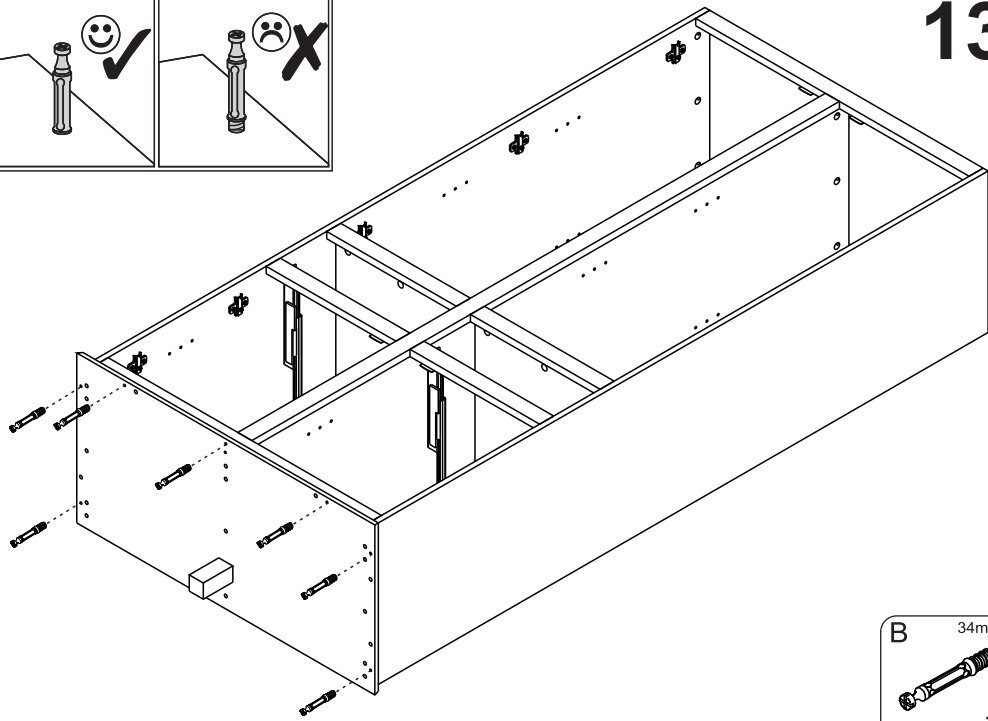

14

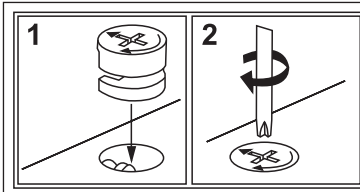
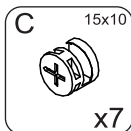
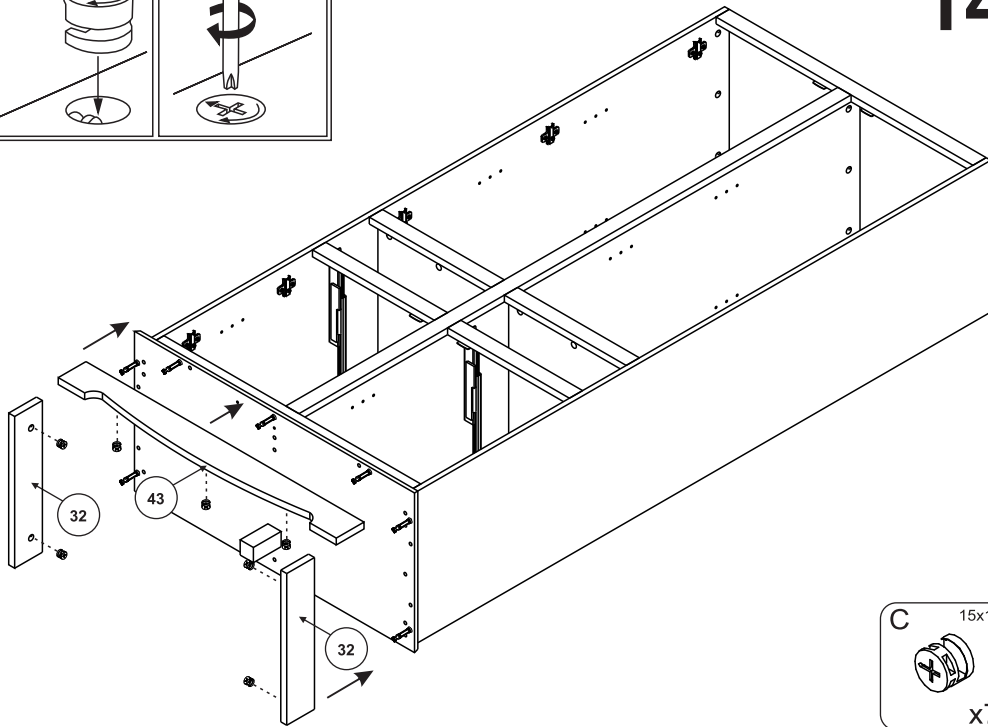

15

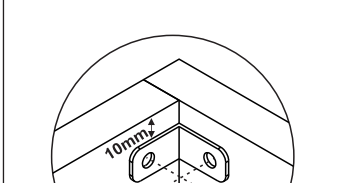
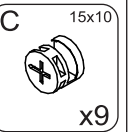
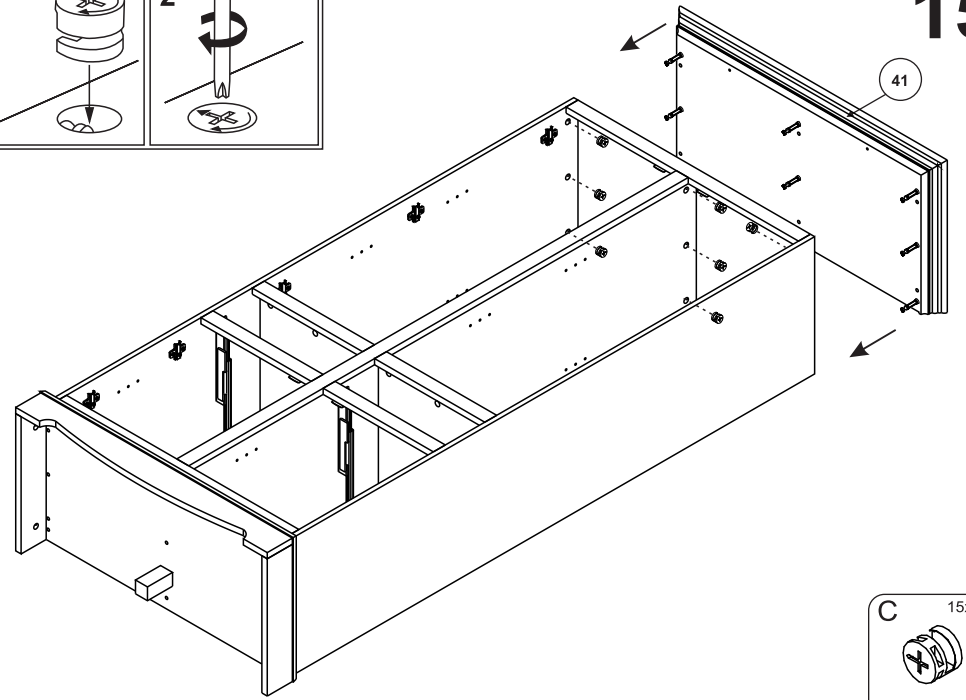

16

