

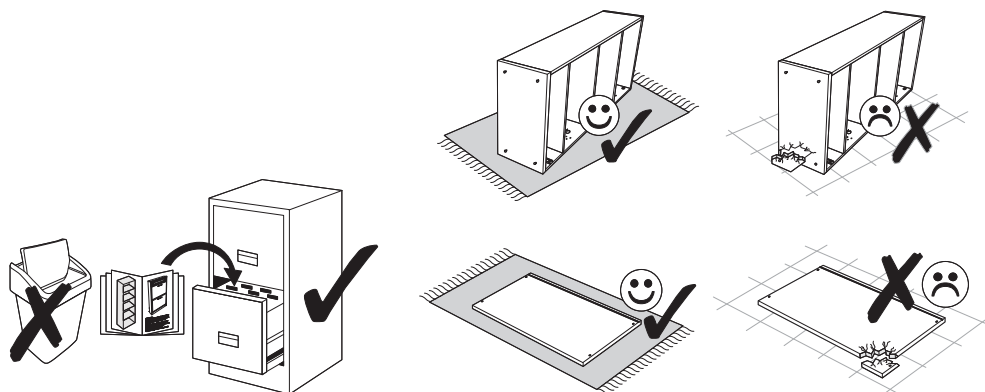

SIKA

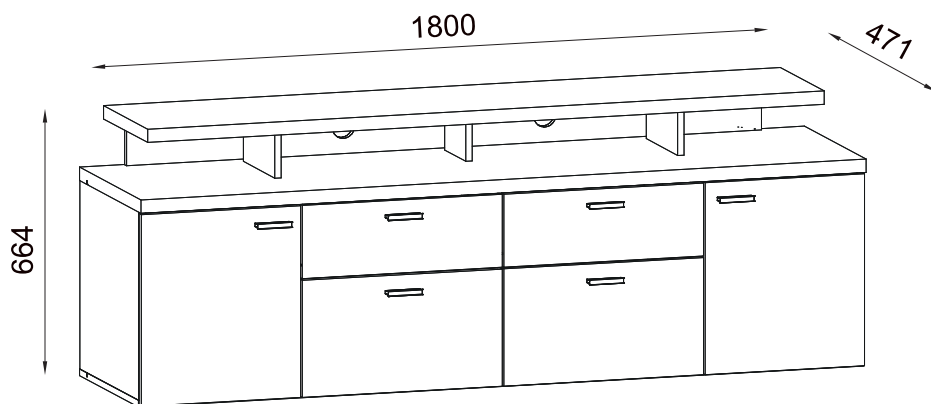

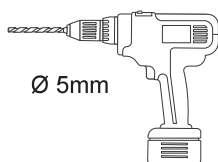
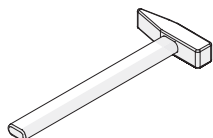
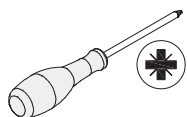
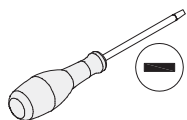
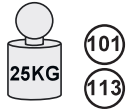

max.



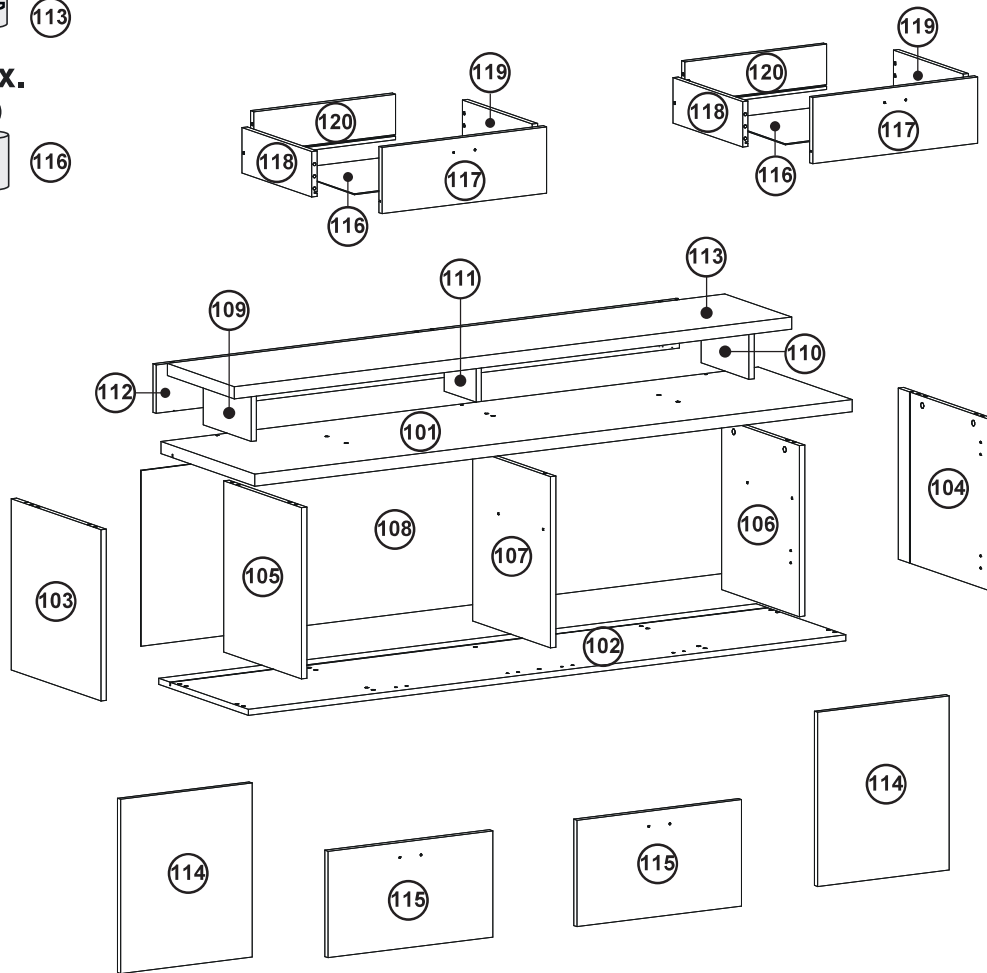
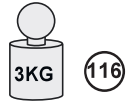

max.

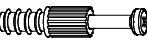



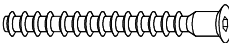
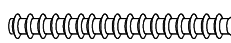
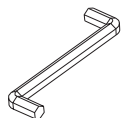

A	B (mm)			C	D	A	B (mm)			C	D
101	1800	471	32	x1	2/2	112	1576	128	16	x1	2/2
102	1800	450	16	x1	2/2	113	1680	336	32	x1	2/2
103	452	450	16	x1	1/2	114	396	460	16	x2	1/2
104	452	450	16	x1	1/2	115	496	281	16	x2	1/2
105	452	390	16	x1	1/2	116	442	348	2,5	x2	1/2
106	452	390	16	x1	1/2	117	496	175	16	x2	1/2
107	452	390	16	x1	1/2	118	350	120	16	x2	1/2
108	1779	464	2,5	x1	2/2	119	350	120	16	x2	1/2
109	128	240	16	x1	1/2	120	427	120	16	x2	1/2
110	128	240	16	x1	1/2	B101					1/2
111	128	160	16	x1	1/2						

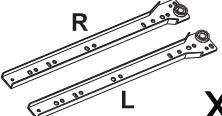
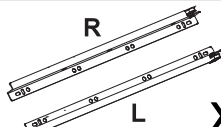

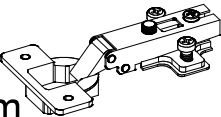
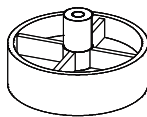
A1 15x12  x21	C4 24mm  x21	O1 ø18mm  x15
--	---	--

F4 7x50  x12	F5 7x70  x3	FA1 4mm  x1
---	--	--

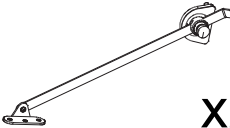
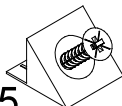
B2 8x30  x45	I3/1 350mm  x2	I3/2 350mm  x2
---	---	---

K6 ø35mm  x8	P15 48x20  x7	J62 64/84  x6
---	--	--

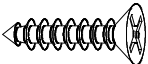
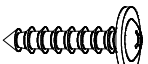
R1 250mm  x2	M1 10x10x15  x10	R5  x2
---	---	--

D11 3,5x16  x24	D15 3x16  x14	D14 4,0x27  x12
--	--	--

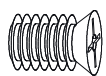
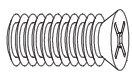
E7 6x8  x4	E8 6,3x13  x4
---	--

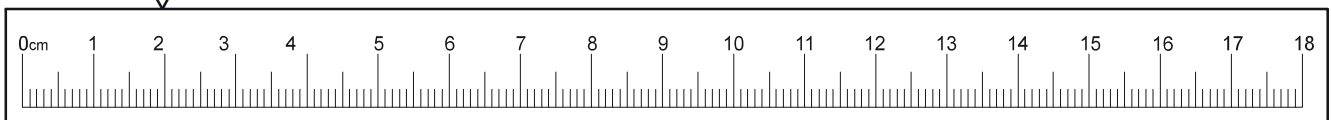
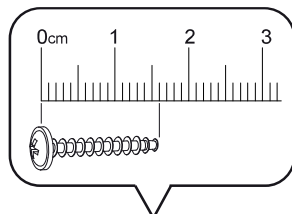



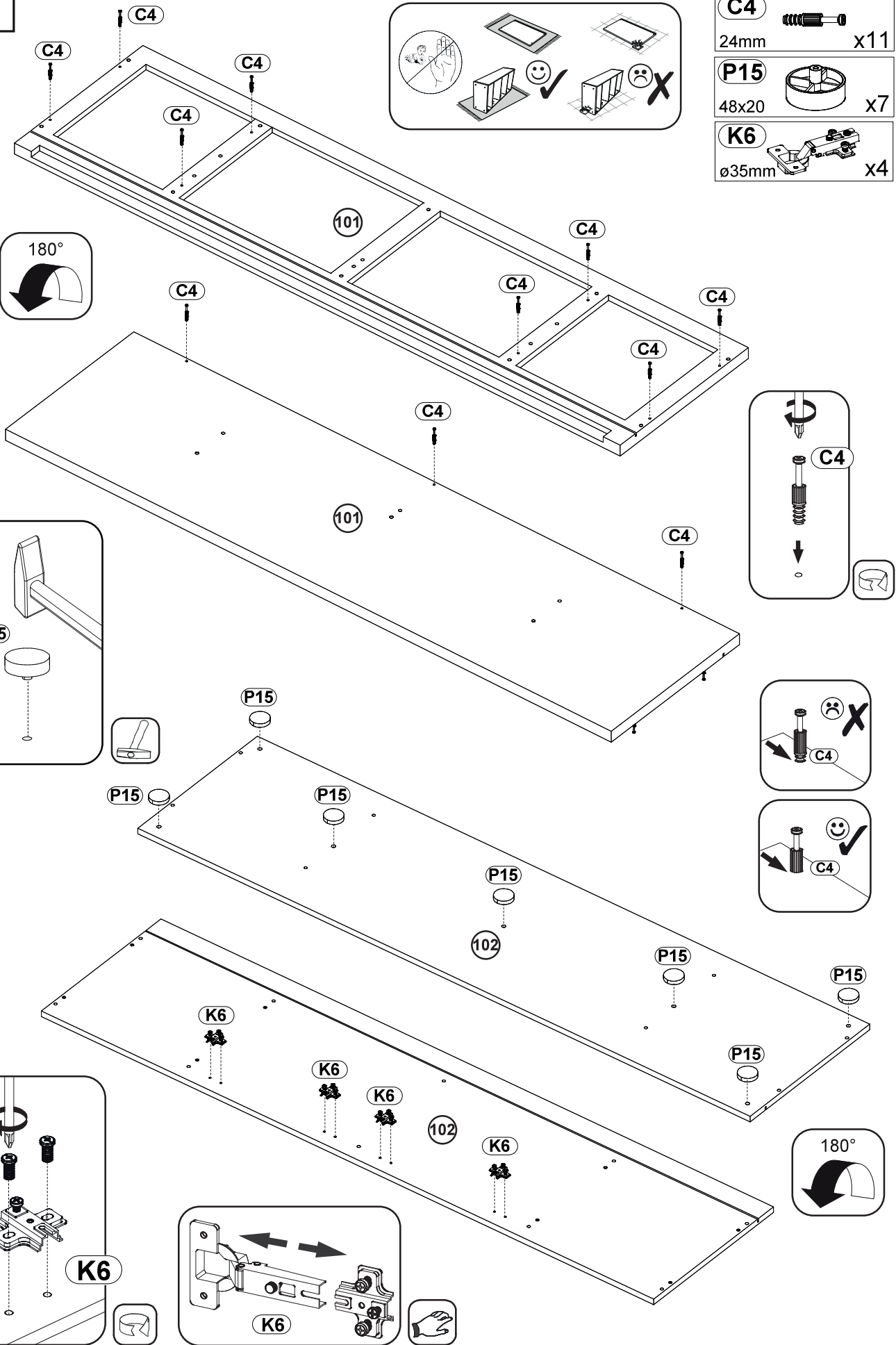

1

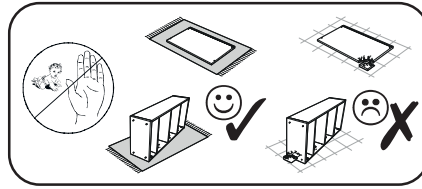

2

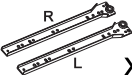

- A1**  x4
15x12
- B2**  x12
8x30
- I3/1**  x2
350mm
- E7**  x4
6x8
- E8**  x4
6,3x13

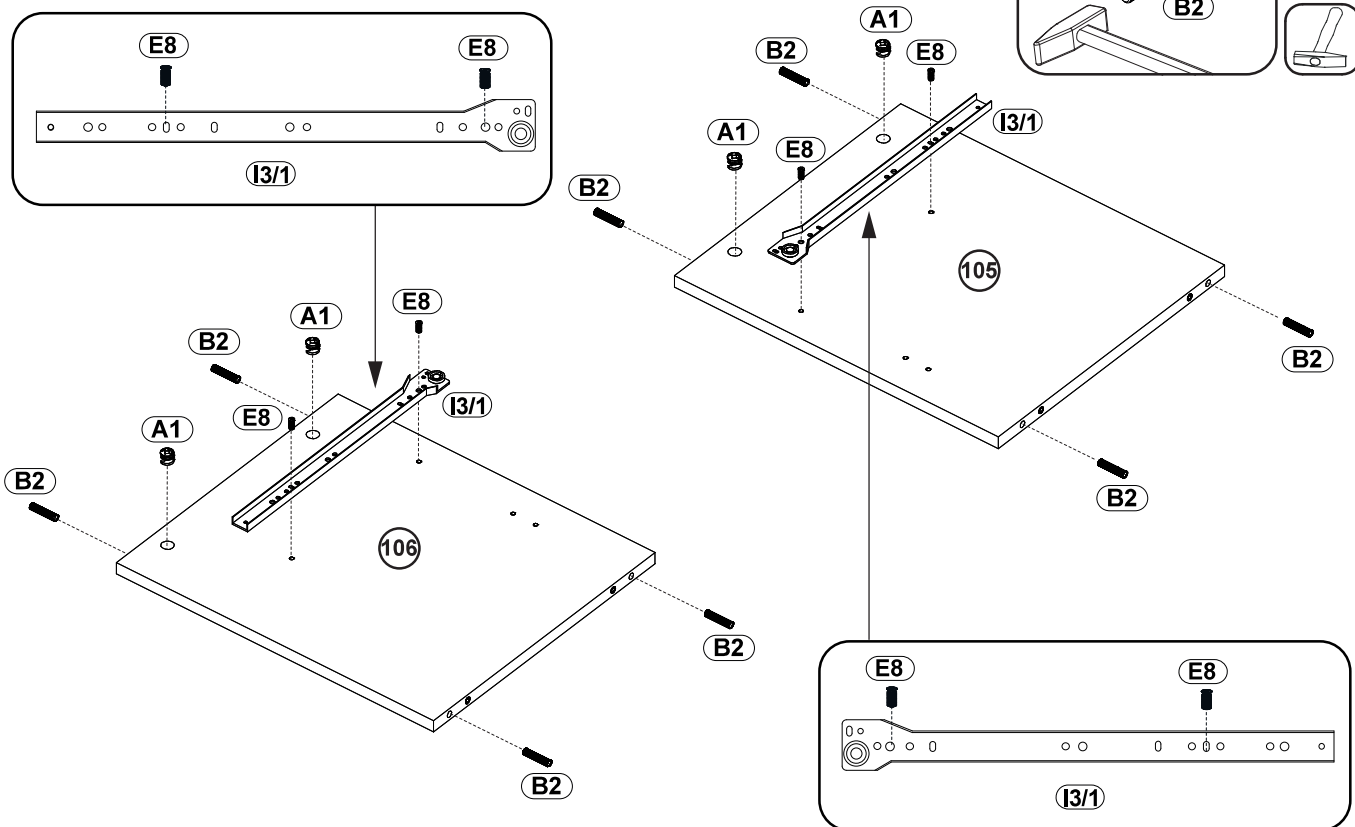
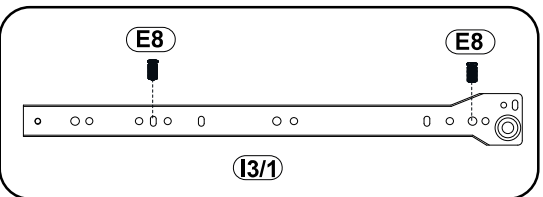
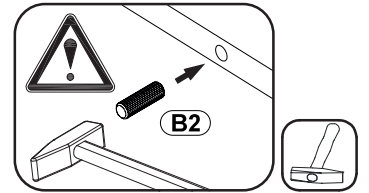
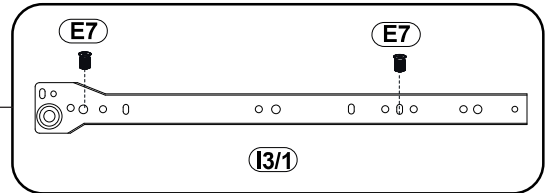
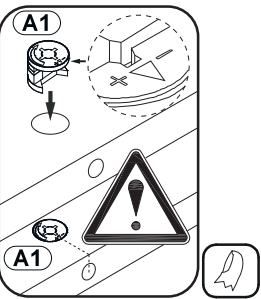
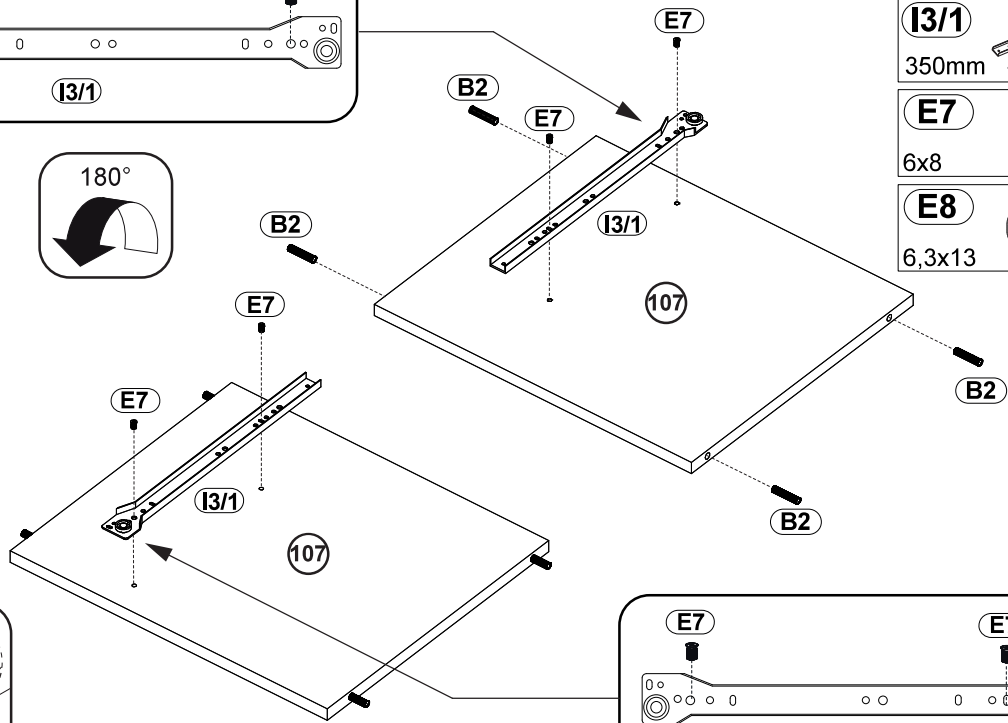
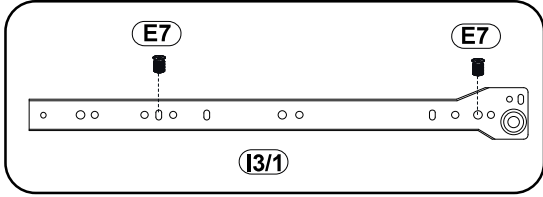

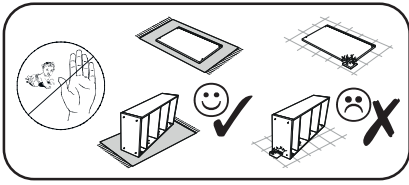

3



A1  x4
15x12



B2  x8
8x30

K6  x4
ø35mm

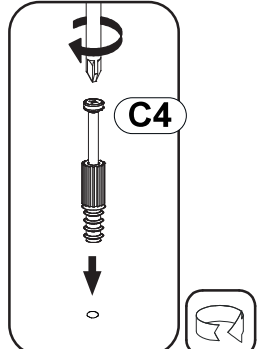
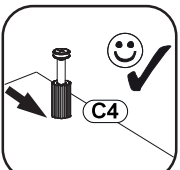
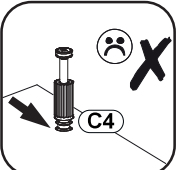
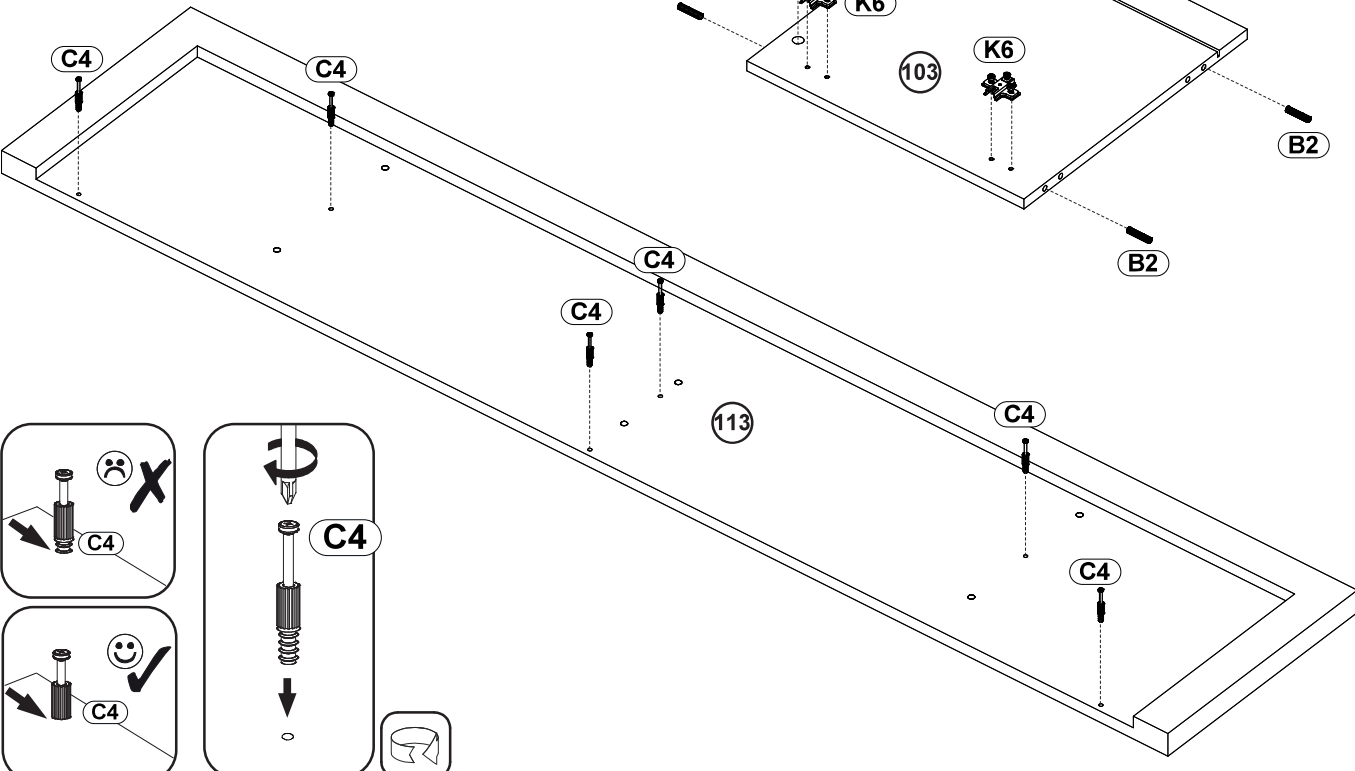
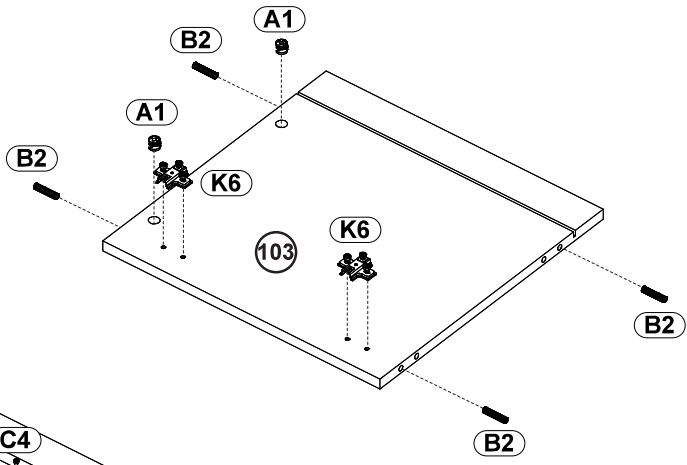
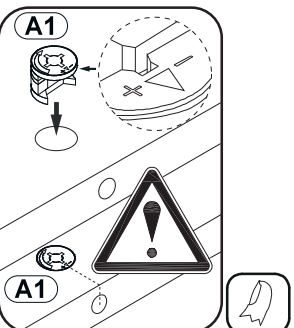
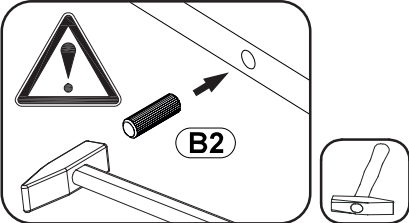
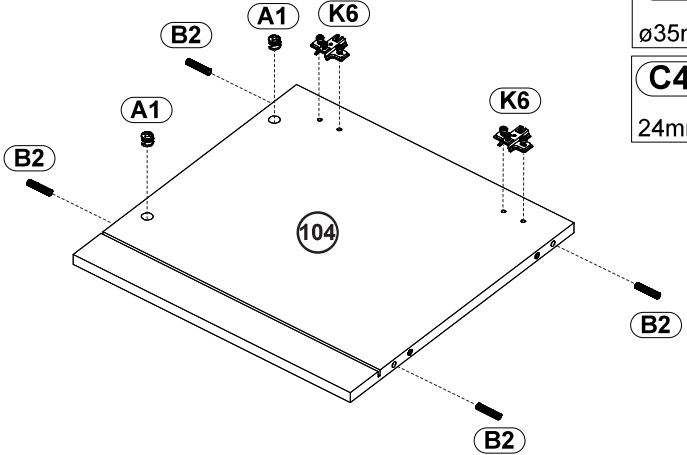
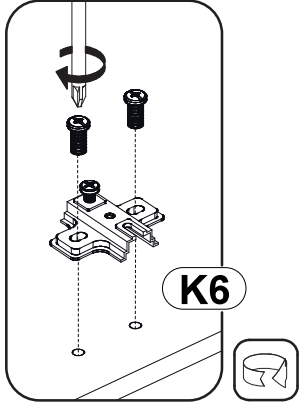
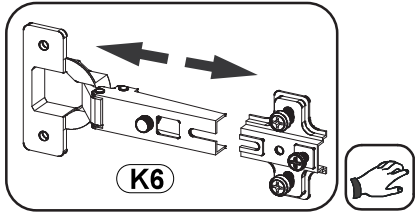
C4  x6
24mm







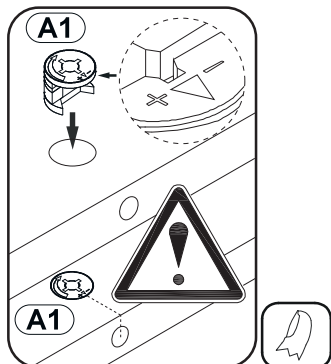
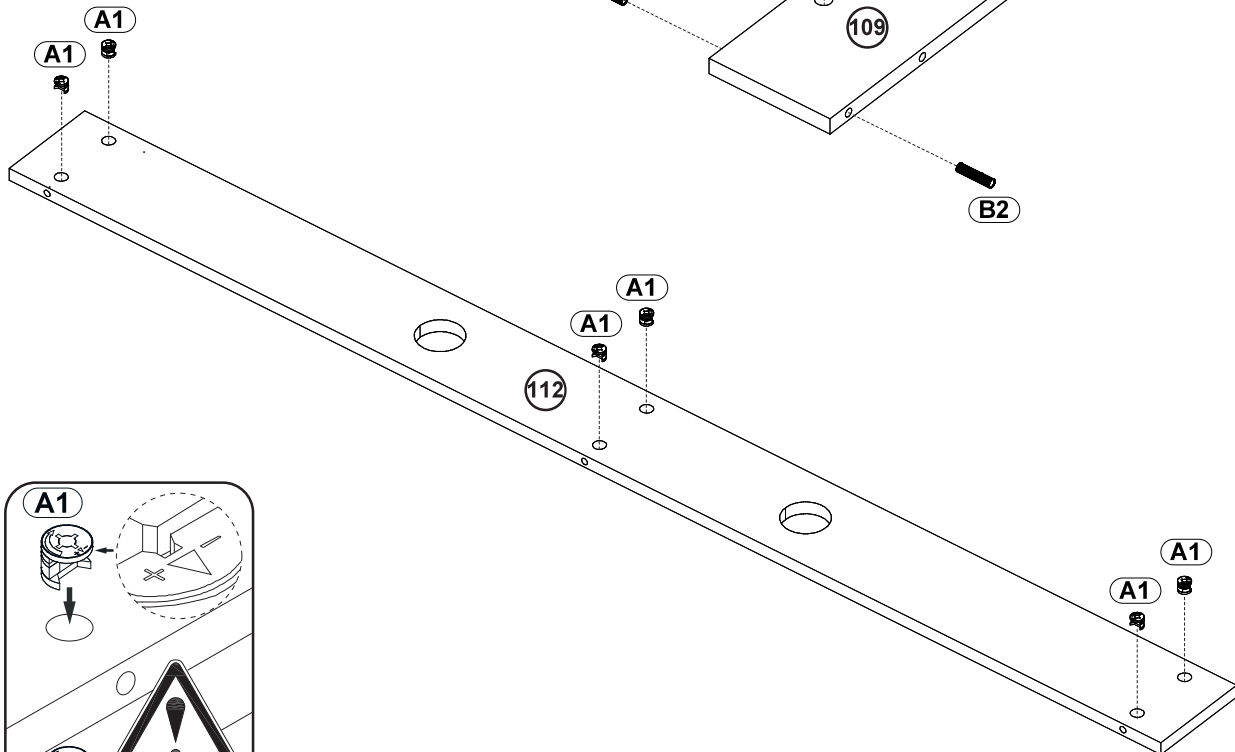
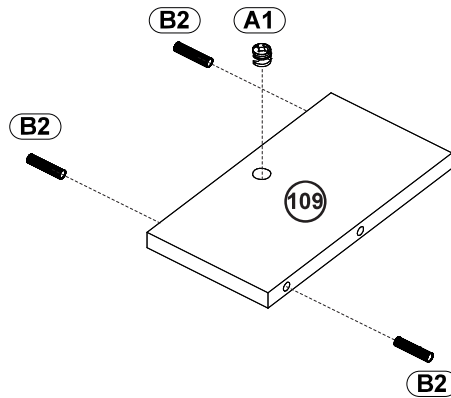
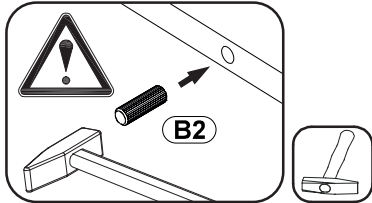
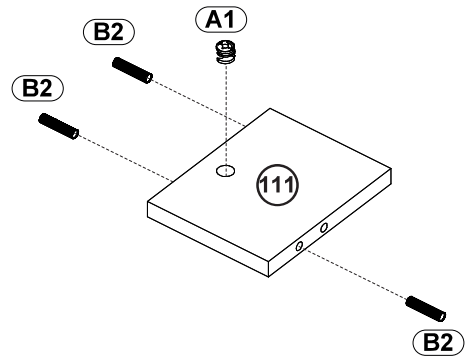
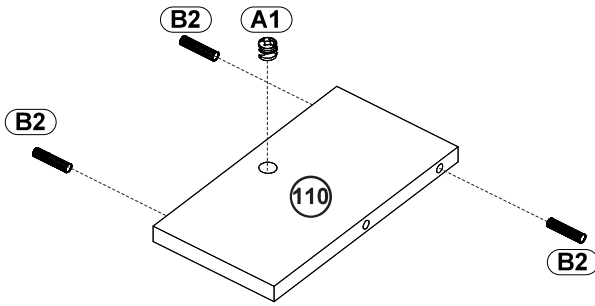
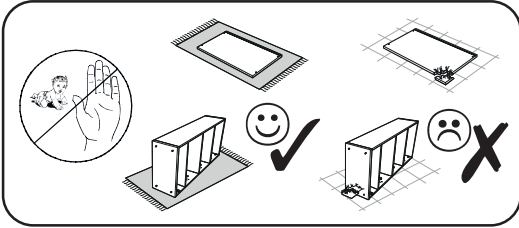

4

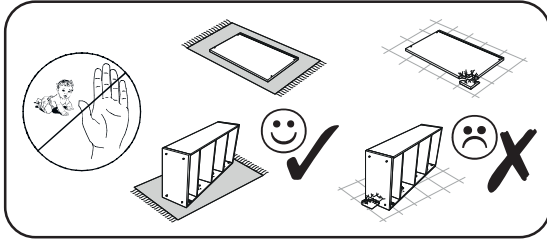
A1		x9
15x12		
B2		x9
8x30		





5

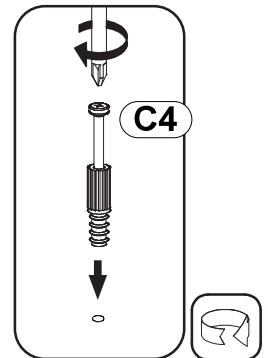
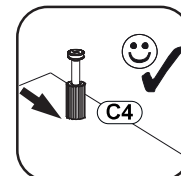
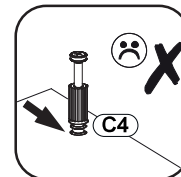
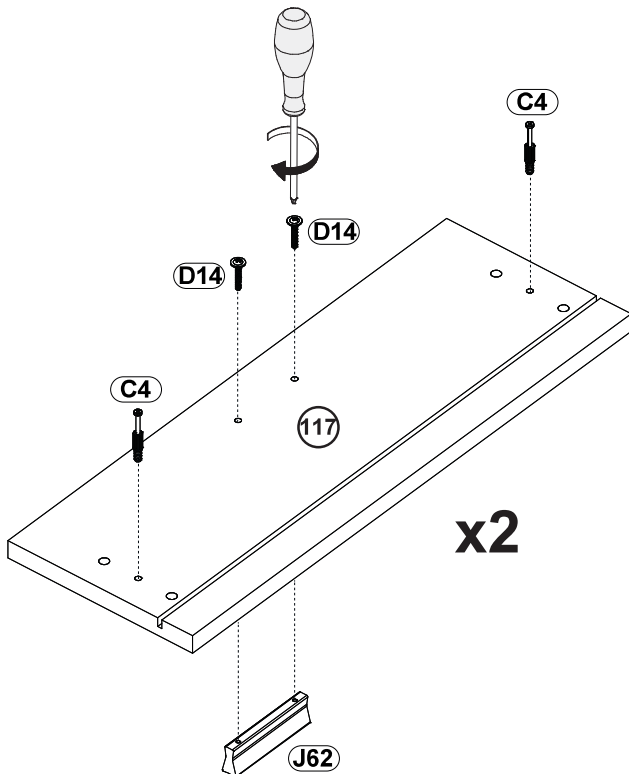
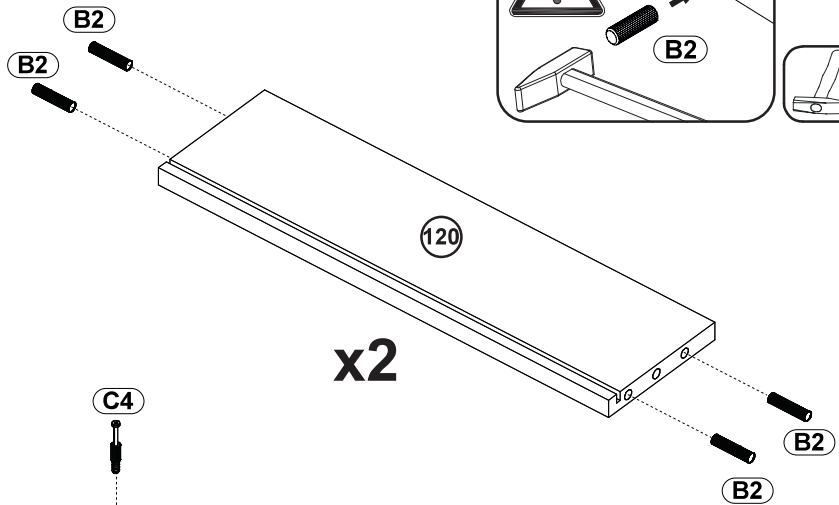
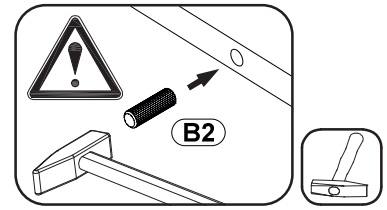
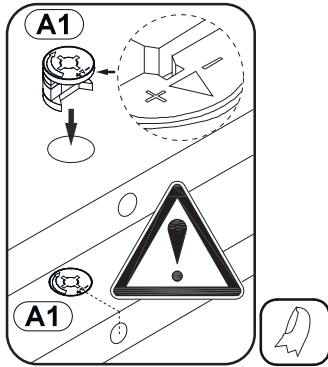
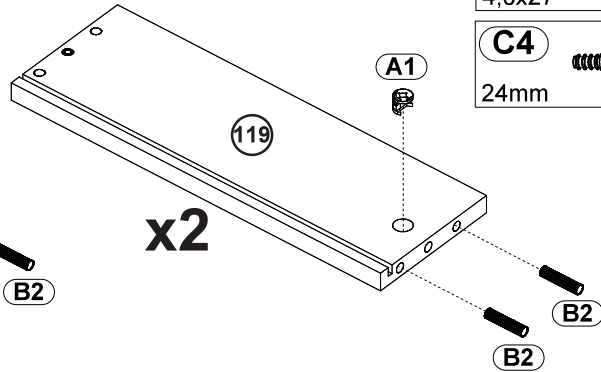
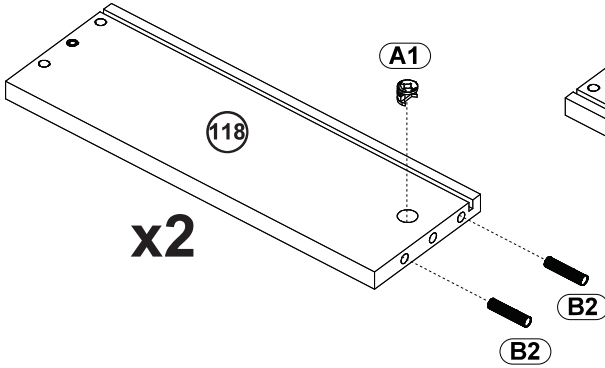

- A1**  x4
15x12
- B2**  x16
8x30
- J62**  x2
64/84
- D14**  x4
4,0x27
- C4**  x4
24mm



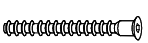

6

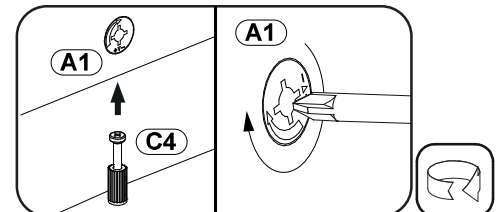
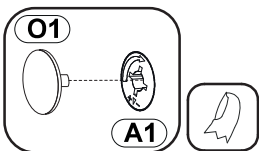
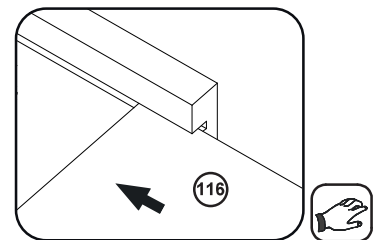
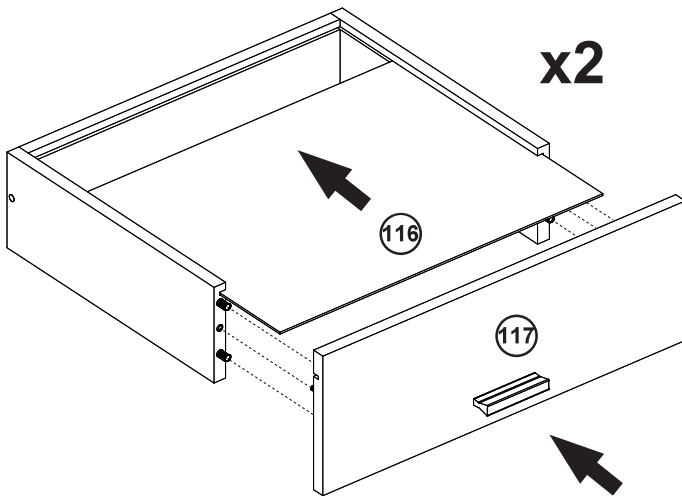
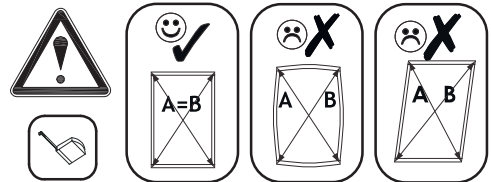
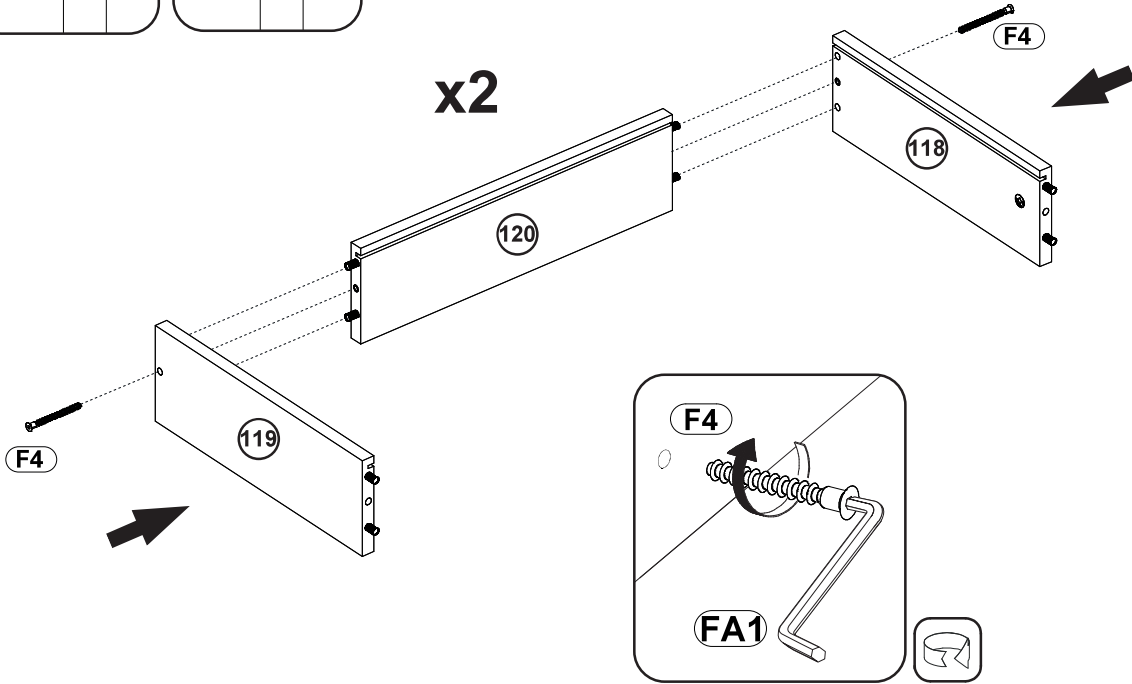
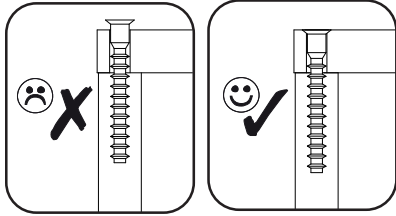
F4		x4
7x50		
FA1		x1
4mm		
O1		x4
ø18mm		



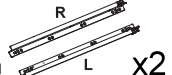

7

I3/2  x2
350mm

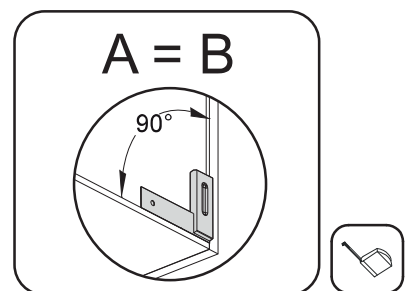
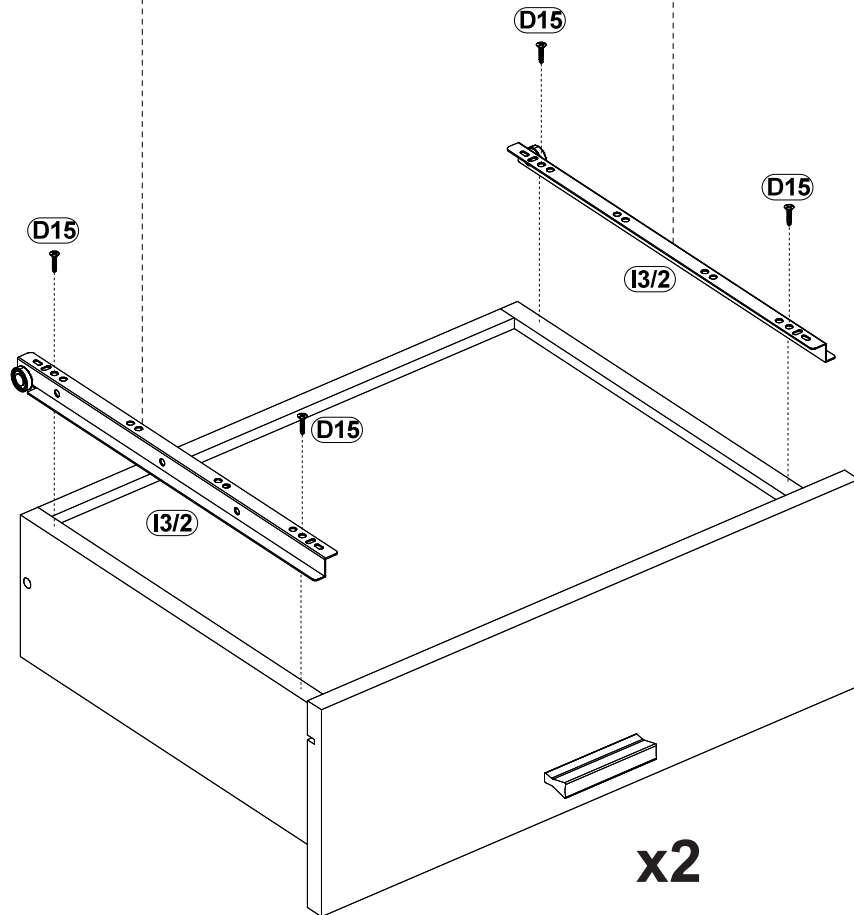
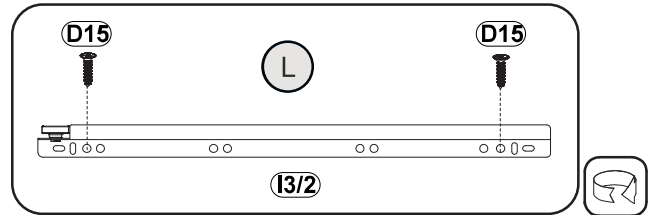
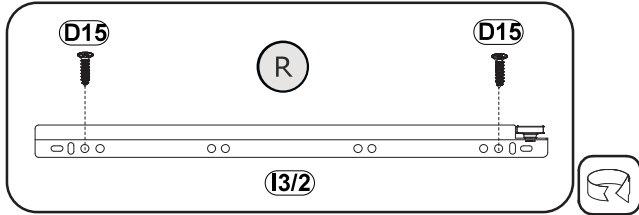
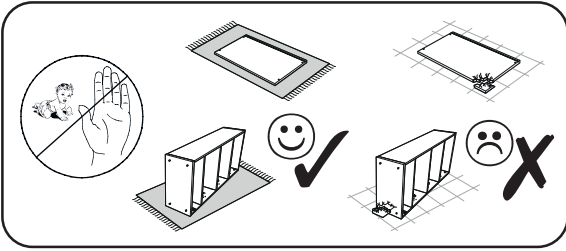
D15  x8
3x16



8

F4		
7x50		x8
FA1		
4mm		x1

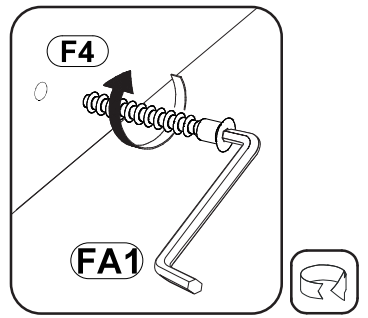
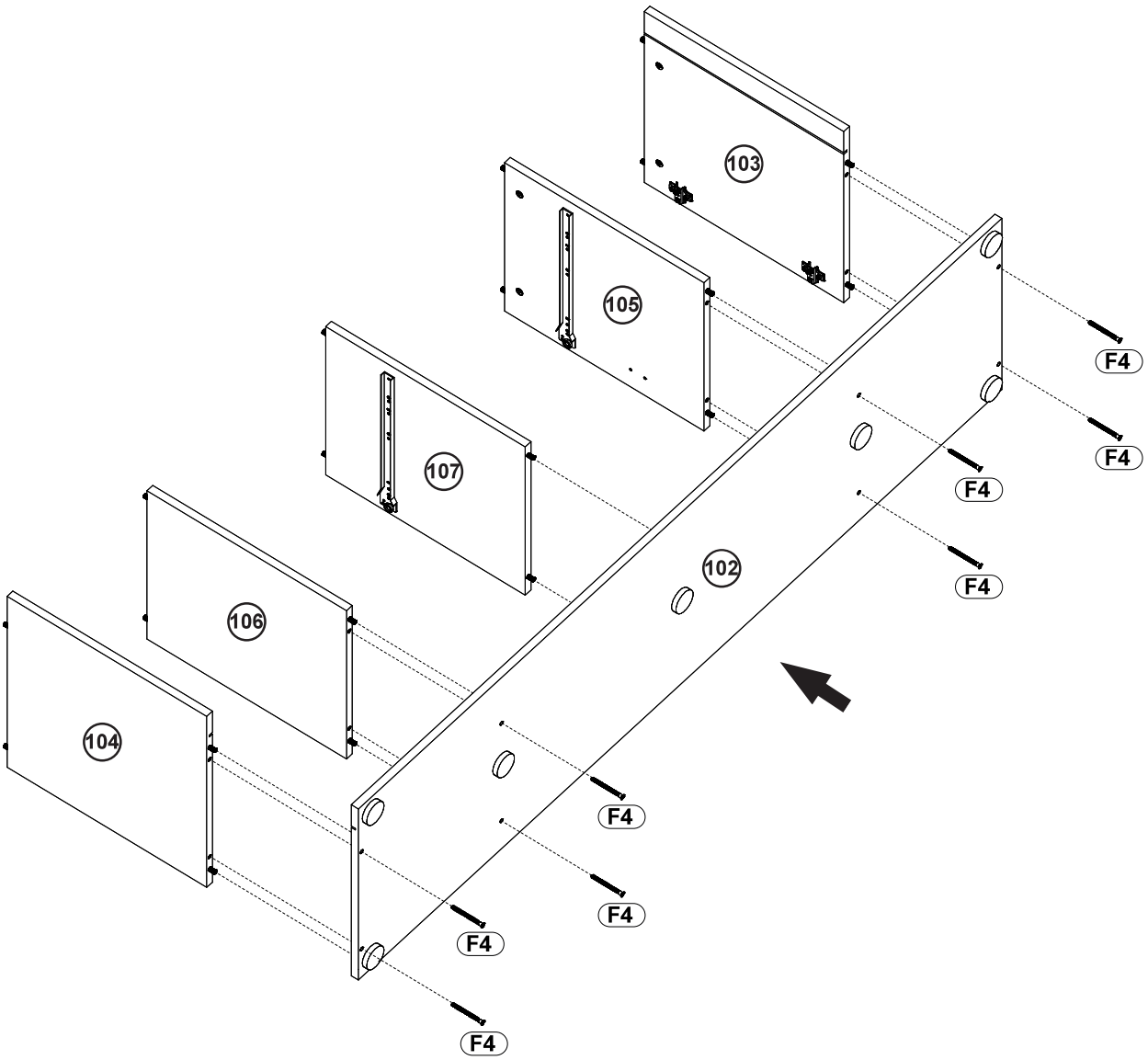
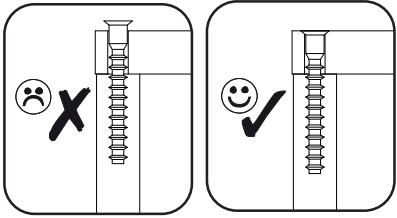

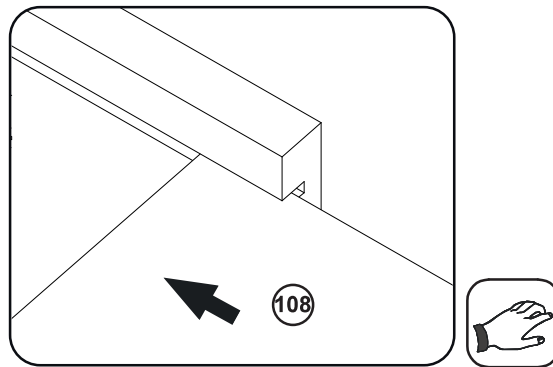
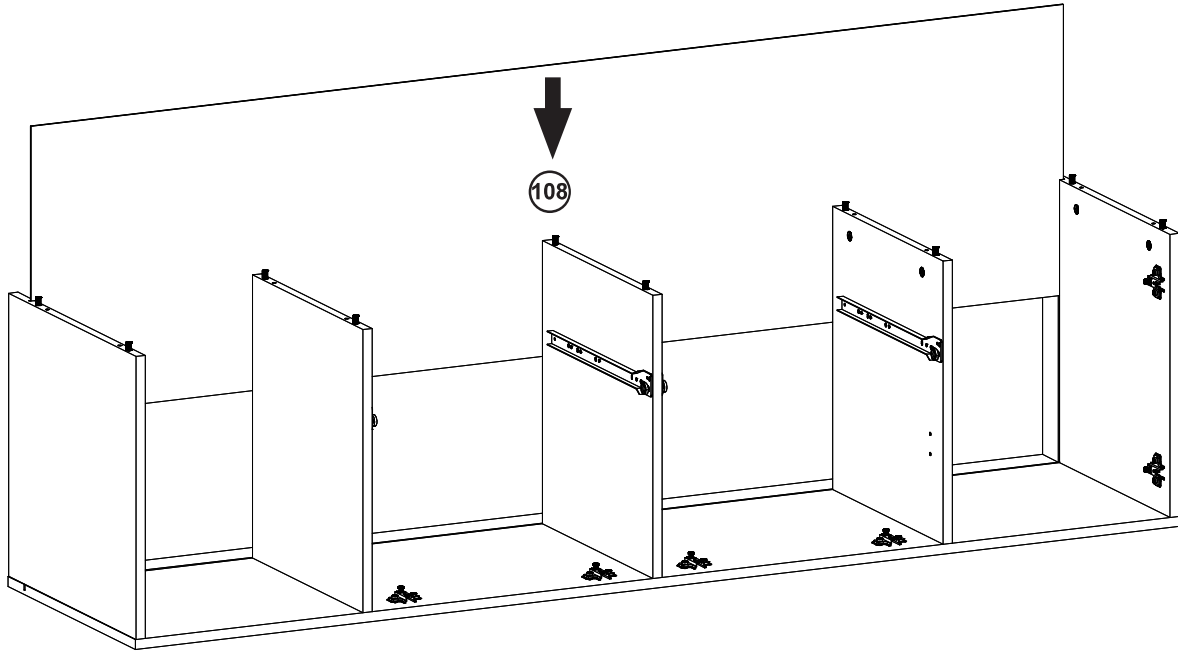

9

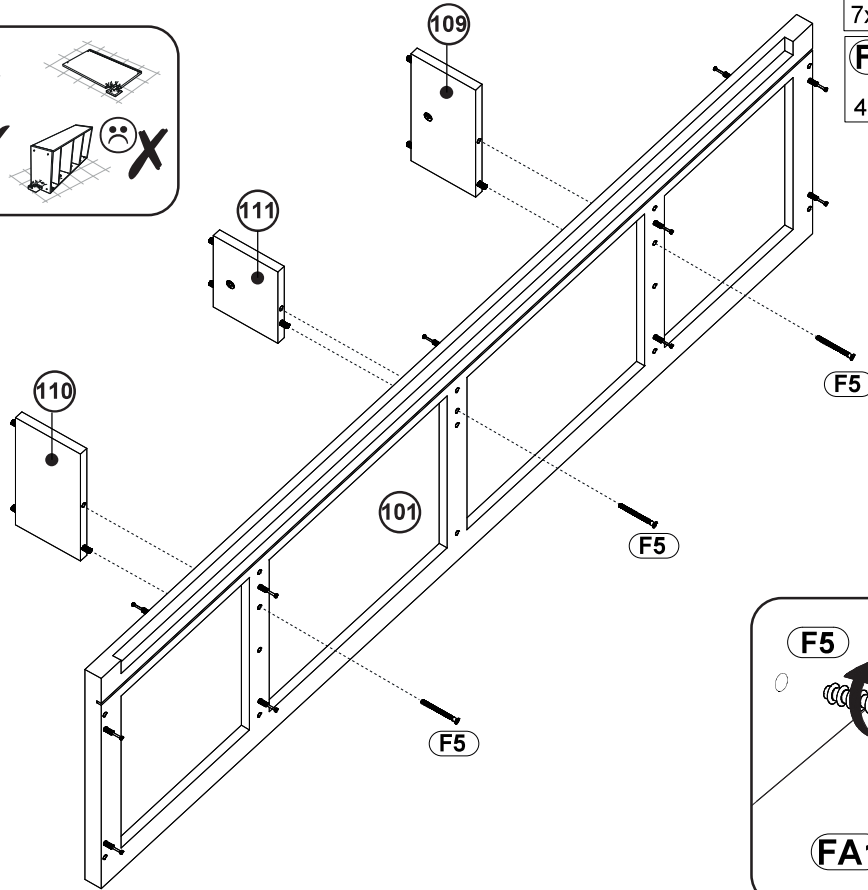
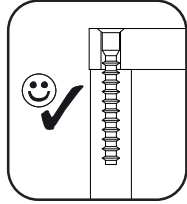
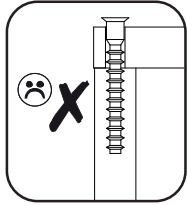
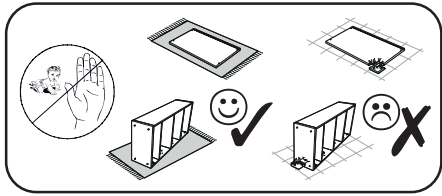

10

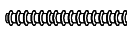

- F5**  x3
7x70
- FA1**  x1
4mm

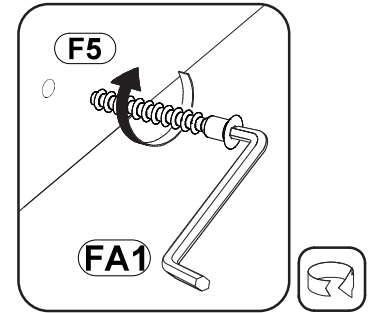

11

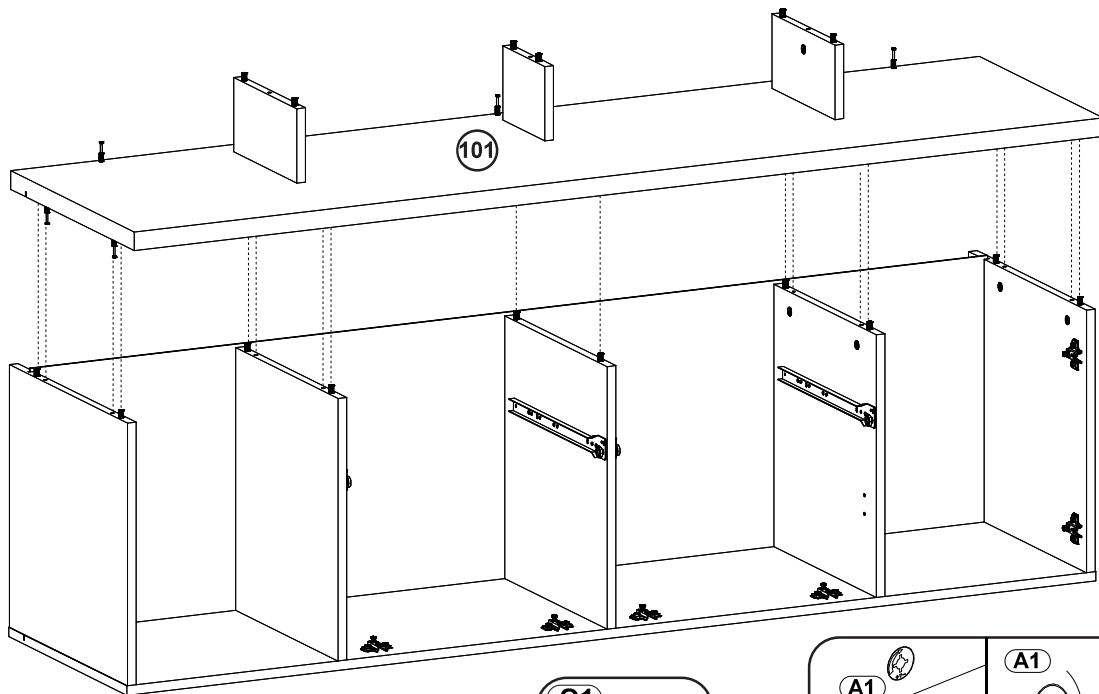

- O1**  x8
ø18mm

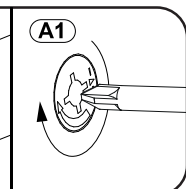
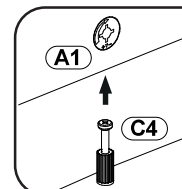
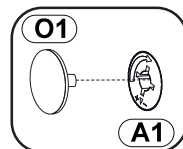

12

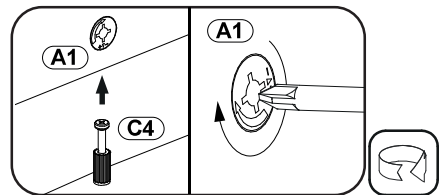
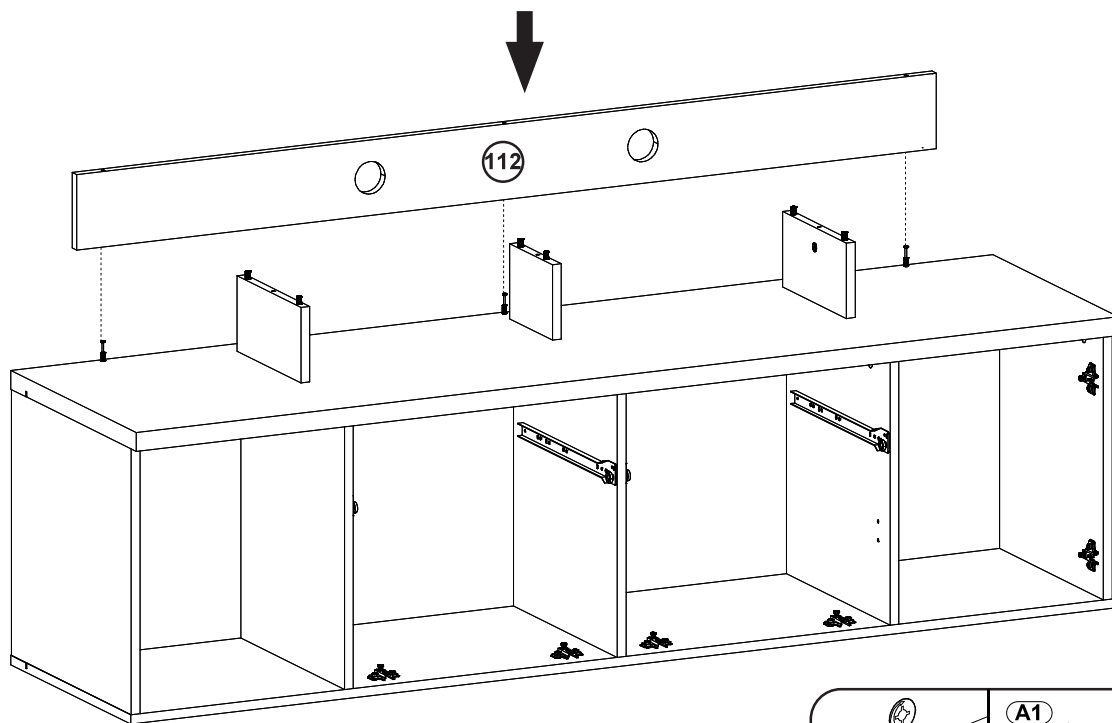

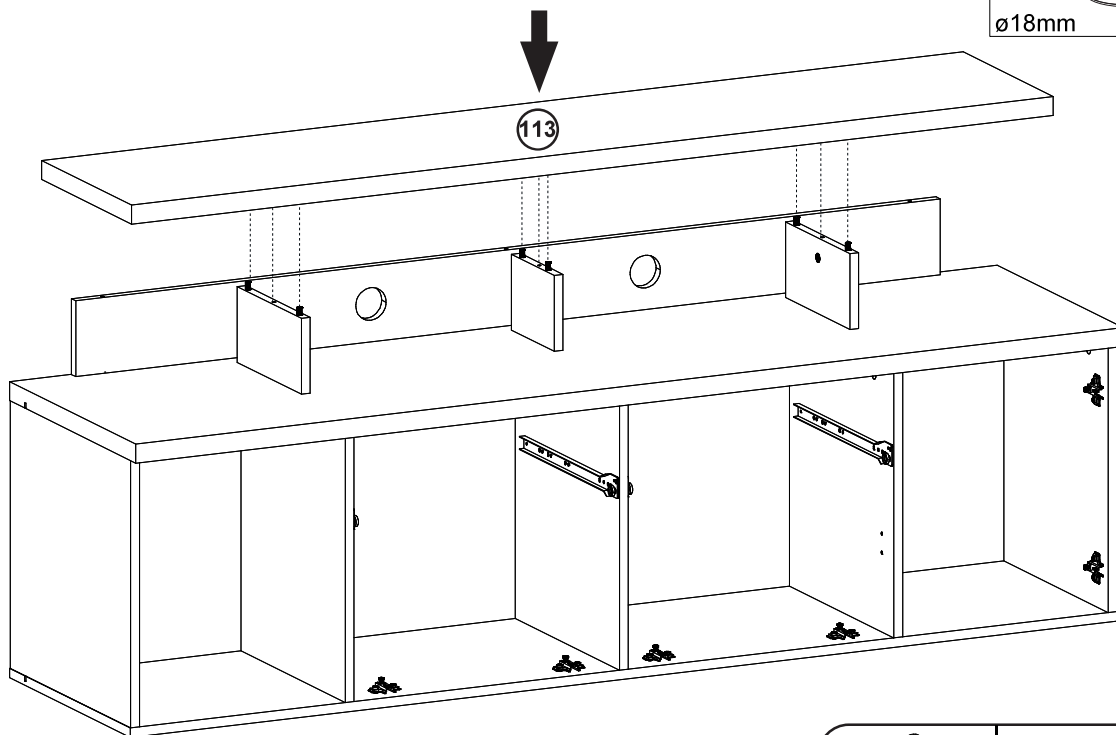

13

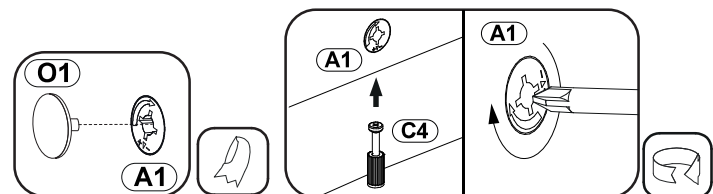

O1
ø18mm x3



14



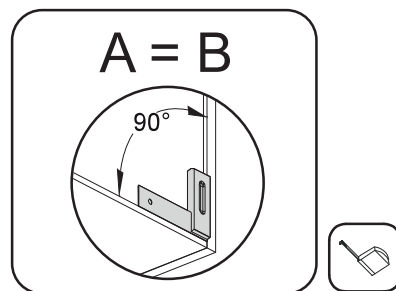
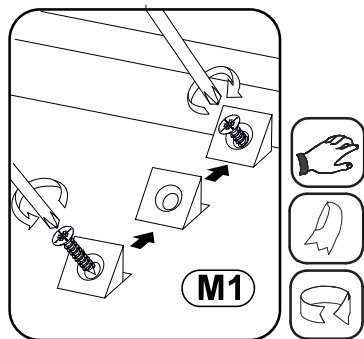
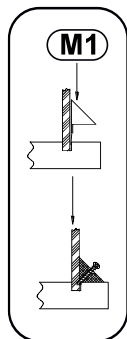
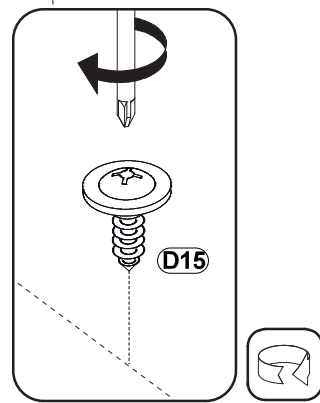
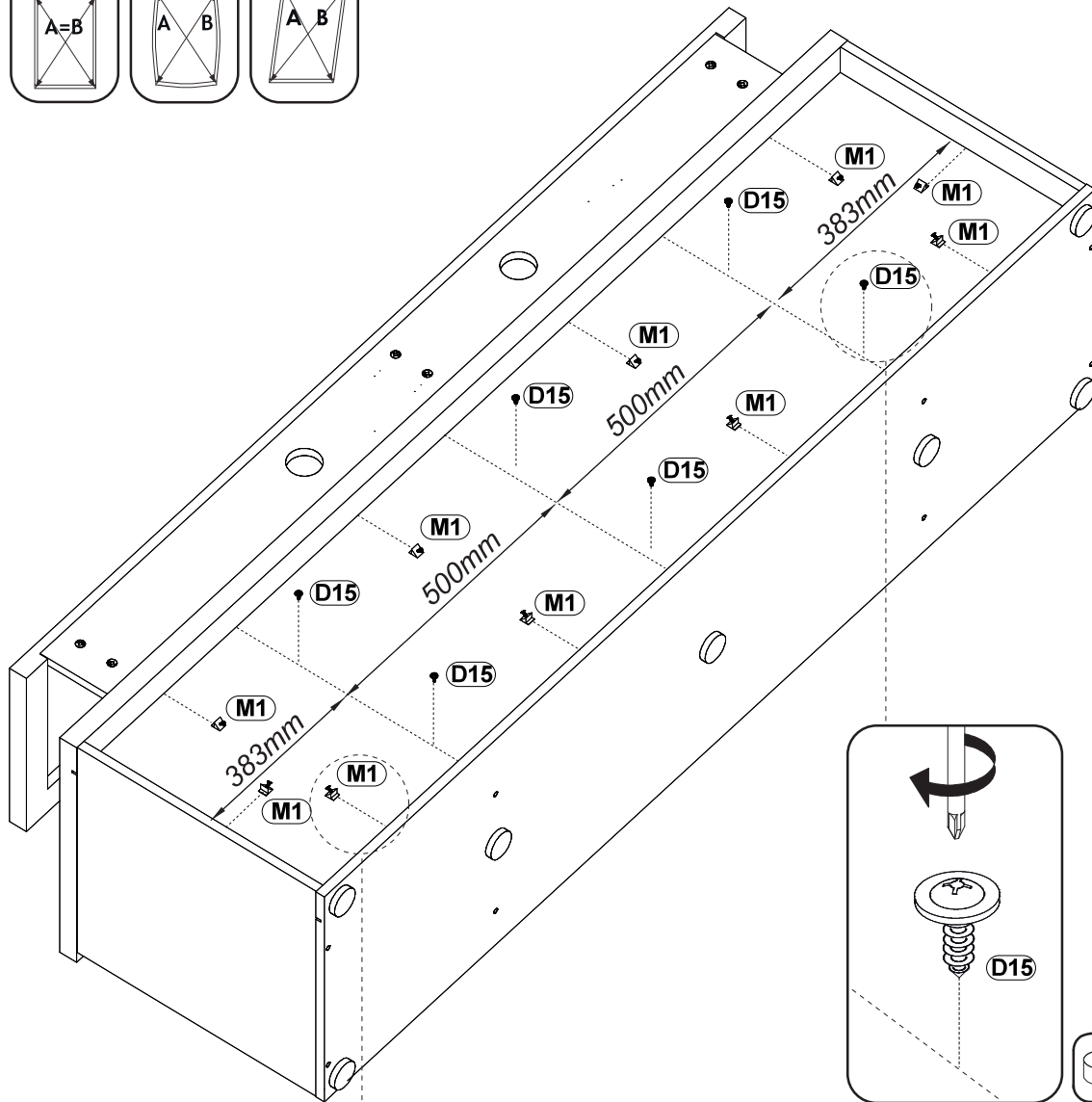
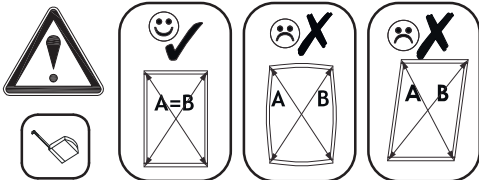
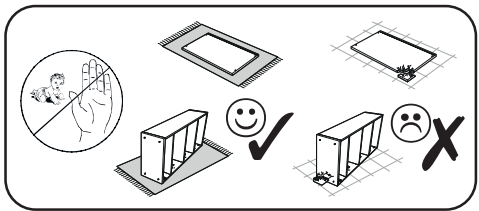

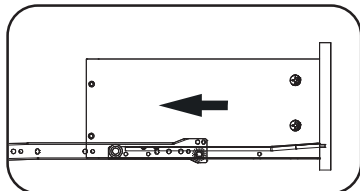
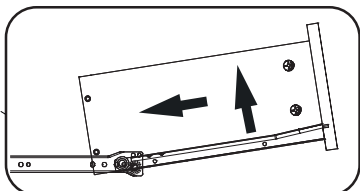
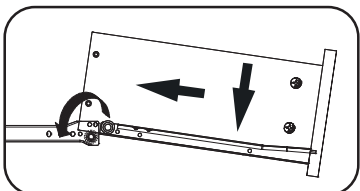
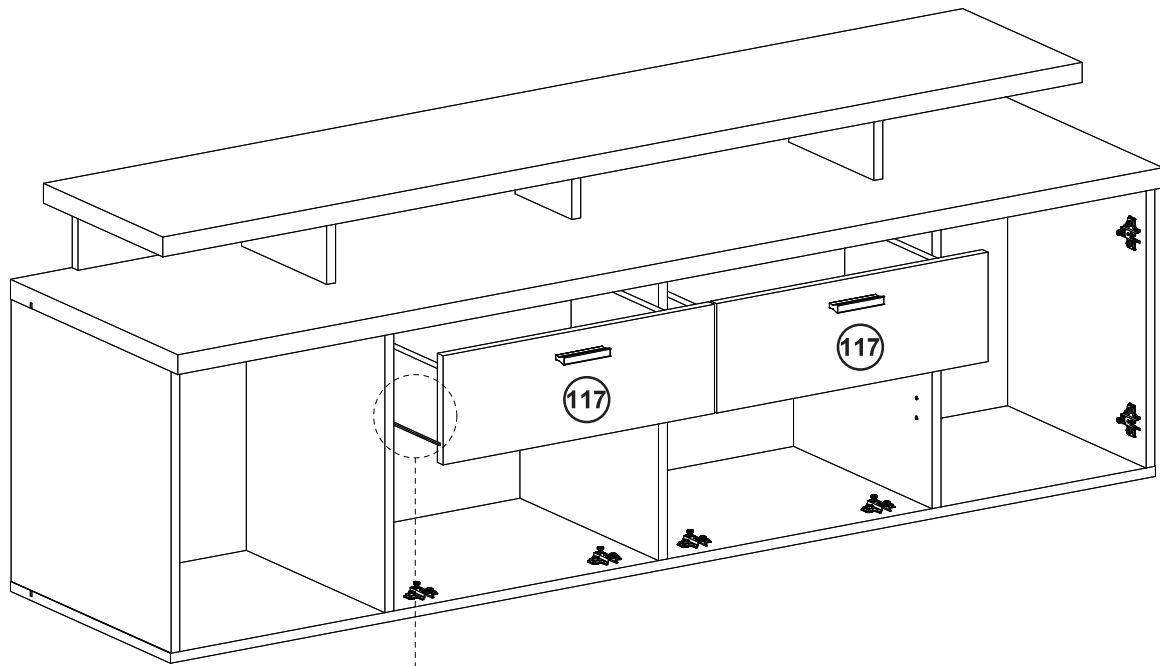
- D15**  x6
3x16
- M1**  x10
10x10x15



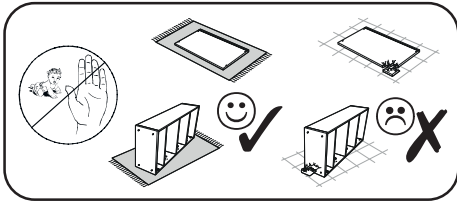

16





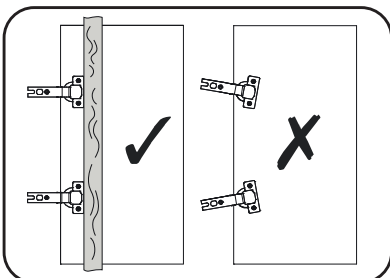
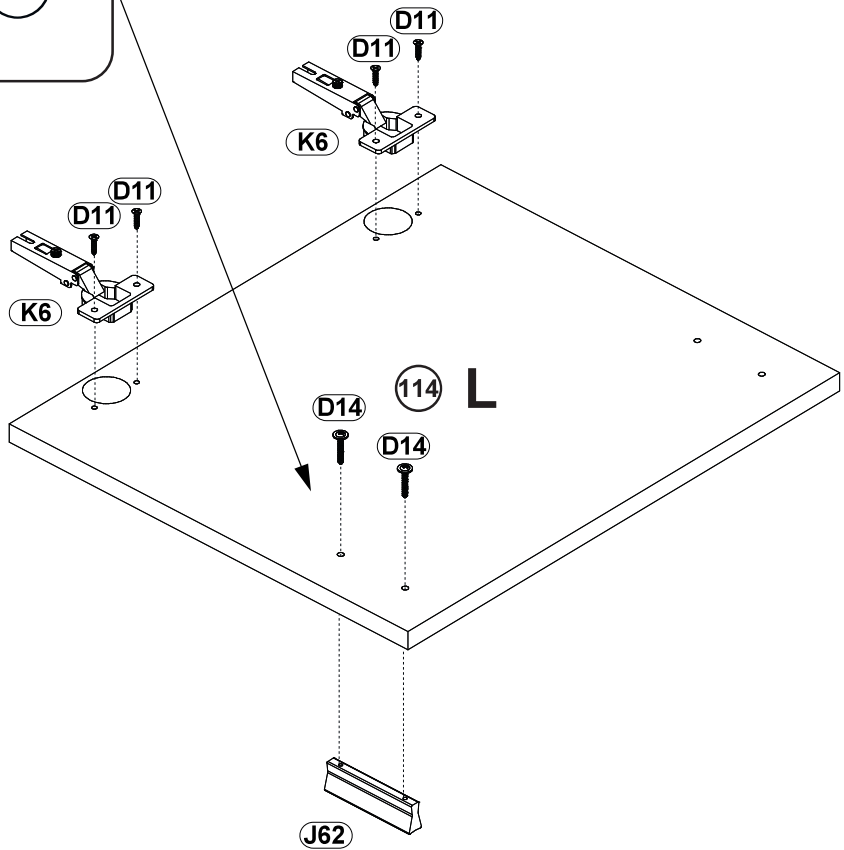
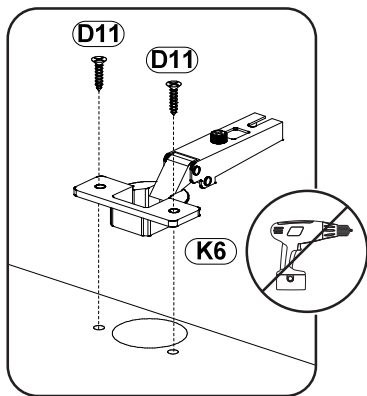
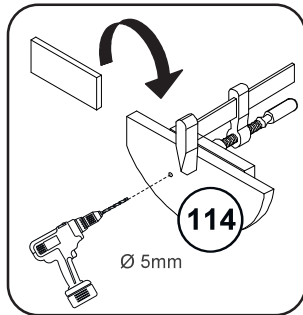
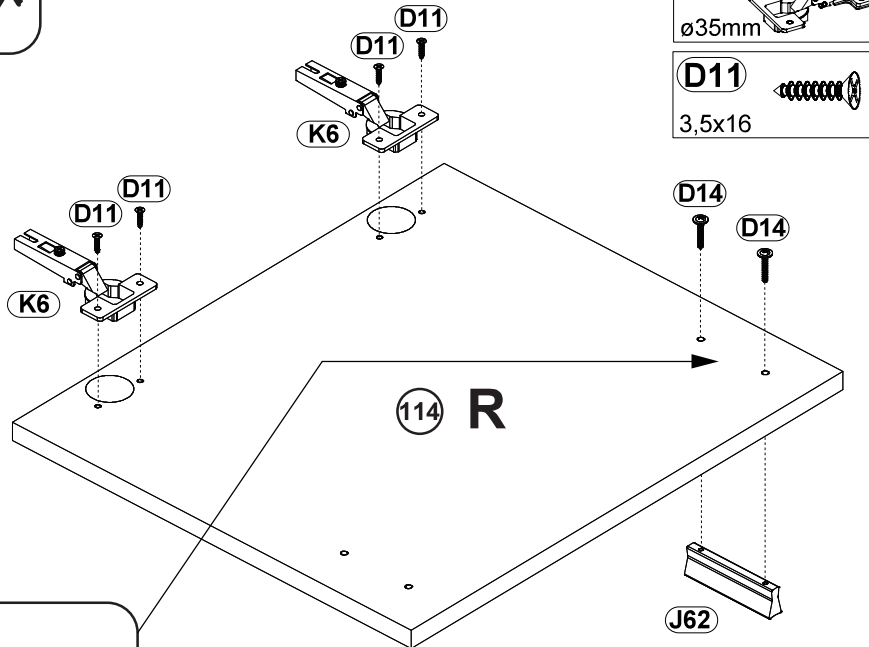

- J62**  x2
64/84
- D14**  x4
4,0x27
- K6**  x4
ø35mm
- D11**  x8
3,5x16

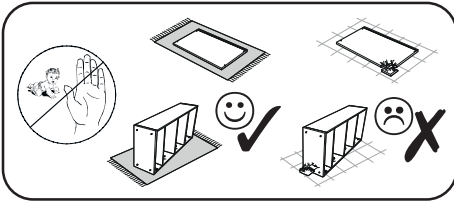

17

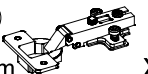

- J62** 64/84 x2 
- D14** 4,0x27 x4 
- K6** ø35mm x4 
- D11** 3,5x16 x8 

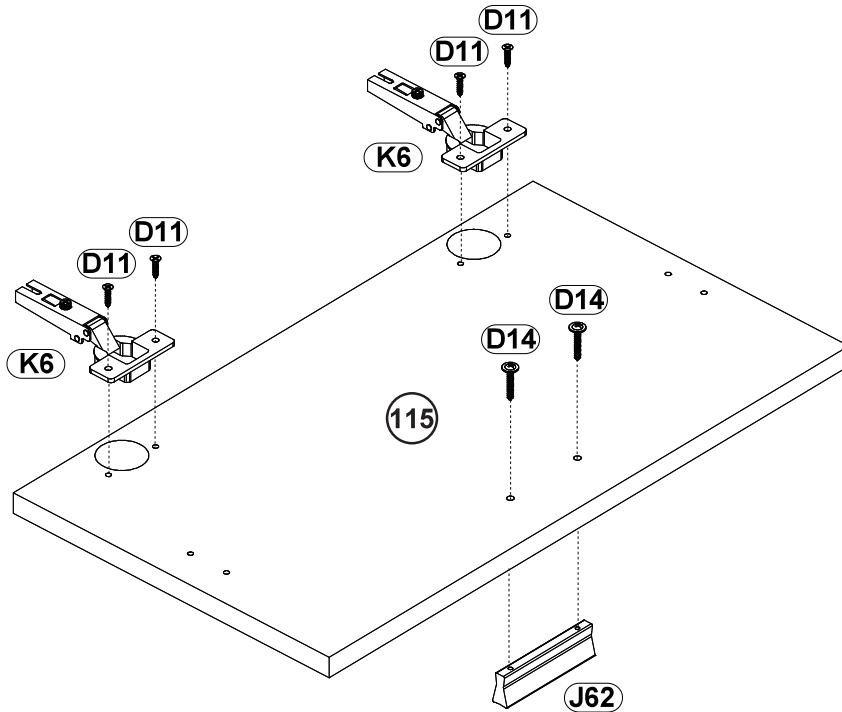

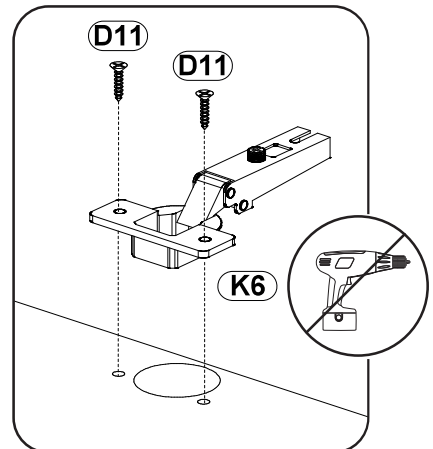
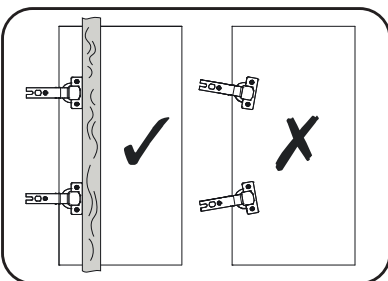

x2

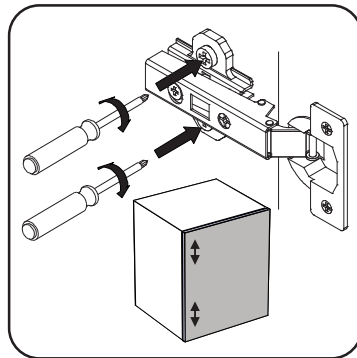
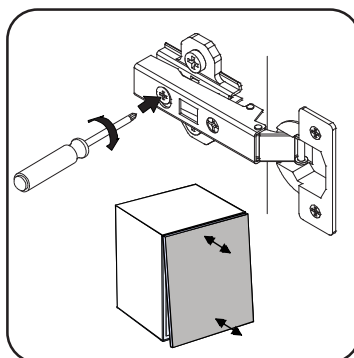
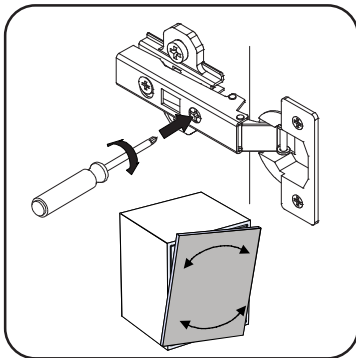
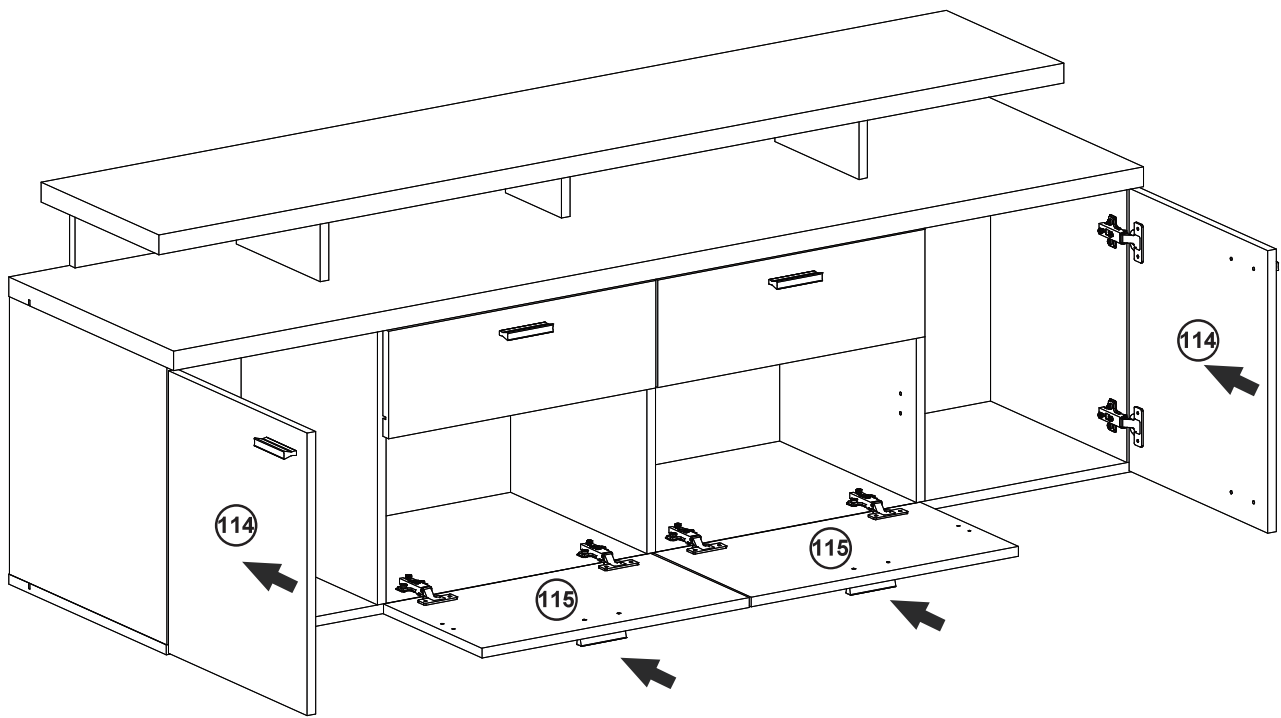
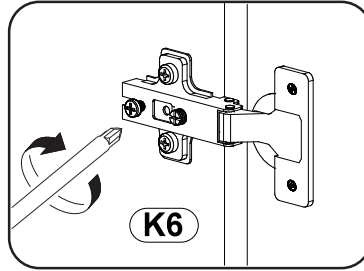
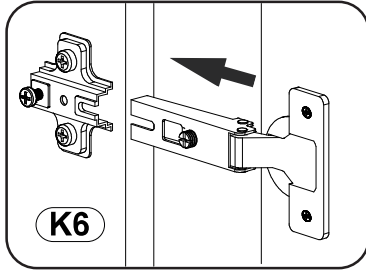

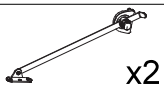

19

- R5**  x2
- R1**  250mm x2
- D11**  3,5x16 x8

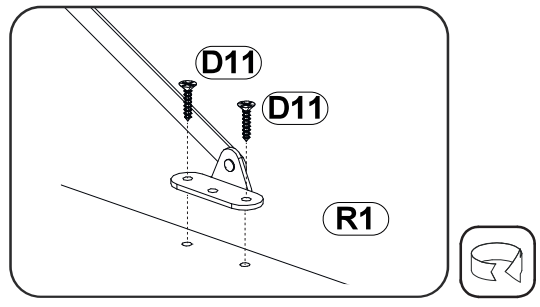
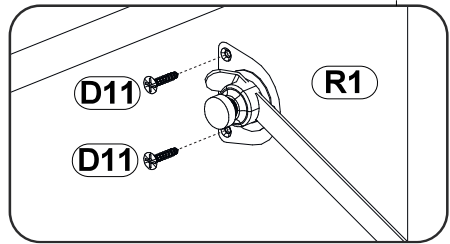
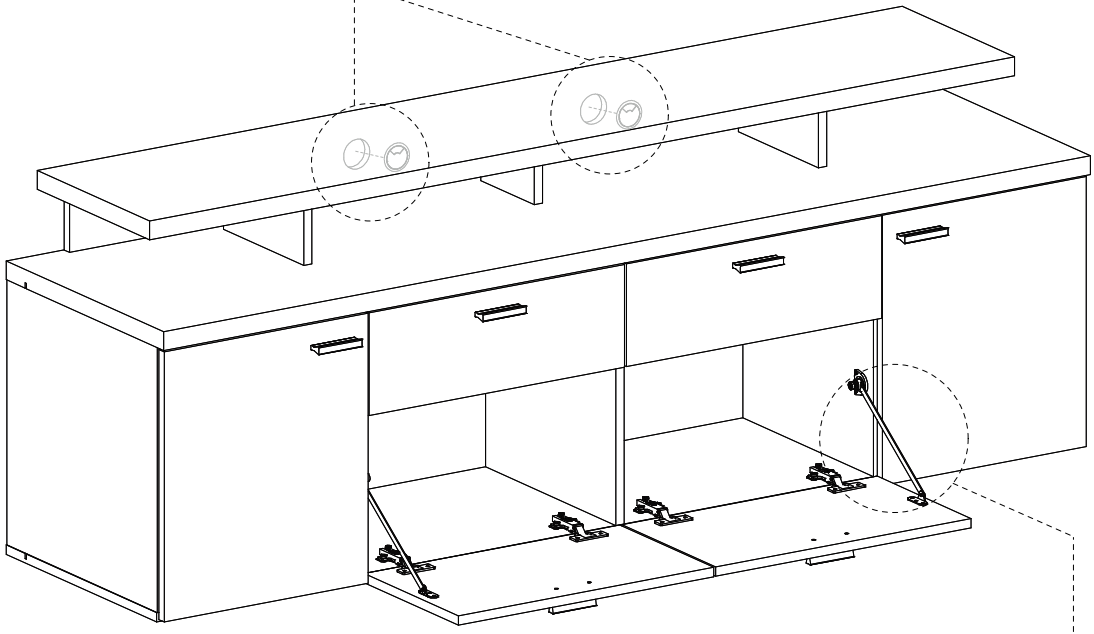
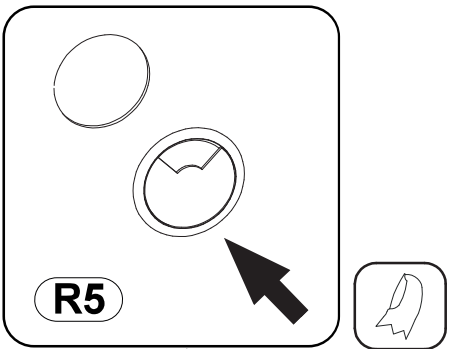

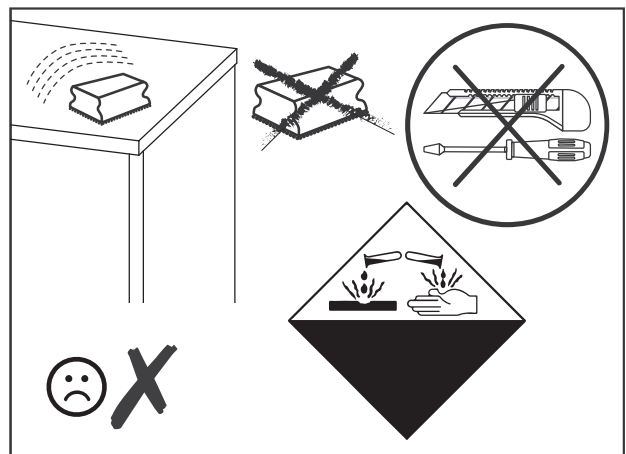
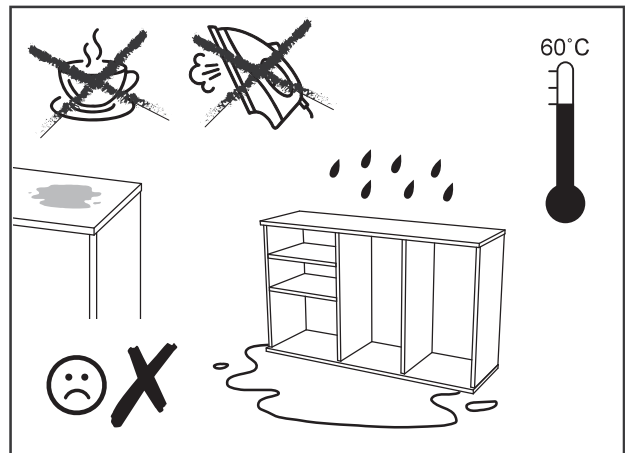
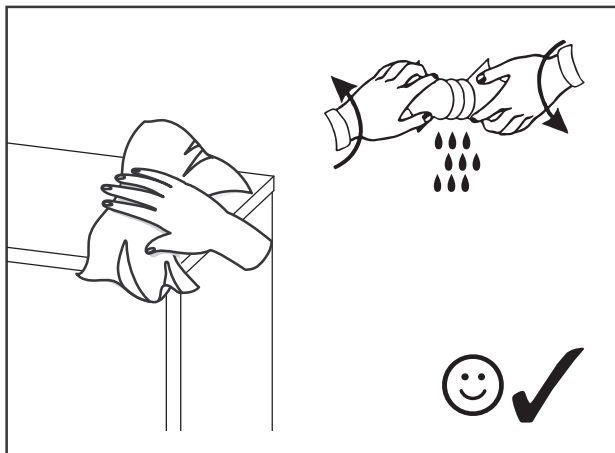
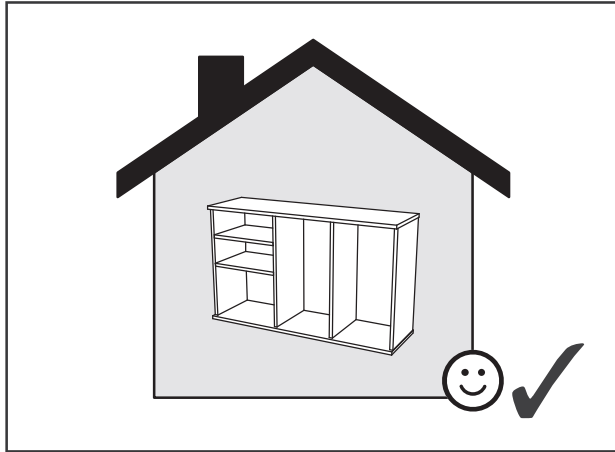

- PL** Powierzchnię mebli należy czyścić tylko środkami do pielęgnacji mebli. Szanowny kliencie w przypadku reklamacji prosimy wypełnić druki reklamacyjne dostępne w punktach sprzedaży przedkładając Kartę Reklamacyjną (zawierającą datę produkcji i numer pakowacza lub zmiany pakowania) umieszczona w każdej z paczek, oraz instrukcję montażu mebla, gdzie prosimy o zaznaczenie uszkodzonego elementu.
- SK** Povrch nábytku čistite iba prostriedkami určenými na ošetrovanie nábytku.Vá ení zákazníci! V prípade reklamácie prosíme, aby ste vyplnili tlačivá, ktoré sú prístupné v obchodoch, predlo ili Reklamačný list (ktorý obsahuje dátum výroby a číslo balíča alebo číslo zmeny pri balení), ktorý sa nachádza v ka dom balení a návod na montáž nábytku, v ktorom označte poškodenú čas.
- CZ** Povrch nábytku čistíte pouze přípravky určenými k ošetřování nábytku.Vá ený zákazník, v případě uplatnění reklamace vyplňte prosím reklamační formuláře, které jsou dostupné v prodejnách a předlo te Reklamační kartu (obsahující datum výroby a číslo balení nebo změny balení, která je umístěna v balíčku) a návod k obsluze s vyznačením poškozeného dílu.
- BG** Повърхността на мебелите трябва да се почиства само с препарати за поддържане на мебели.Уважаеми клиенти, в случай на reclamaция моля попълнете формулярите за reclamaция, които ще получите в търговските пунктове, като представите Картата за reclamaция (съдържаща датата на производство и номера на опаковчика или смяната за опаковане), която ще намерите във всяка опаковка, и инструкцията за монтаж на мебела, върху която да отбележите повредения елемент.
- RO** Suprafața ei trebuie să fie curățată numai cu substanțe destinate pentru curățarea mobilei.Stimate Cumpărător, în caz de reclamație vă rugăm să completați formularul de reclamație pe care îl puteți lua de la punctul de vânzare și pe care îl veți prezenta împreună cu Cartela de Garanție (care conține data producției și nr ambalatorului sau țurei de ambalare), însoțită la fiecare ambalaj, precum și instrucțiunile de montaj ale mobilei, pe care vă rugăm să marcați elementul deteriorat.
- UA** Поверхню меблів потрібно чистити тільки засобами для догляду за меблями.Шановний клієнте для заяви рекламачії, просимо заповнити формуляр рекламачії, доступний у пунктах продажу, вказуючи рекламачійну карту (містить дату виробництва та номер пакувальника або зміни упаковки), прикладену до кожного пакету, а також інструкцію з монтажу меблів, на якій просимо позначити пошкоджений елемент.
- RUS** Поверхность мебели надо чистить только средствами для ухода за мебелью.Уважаемый клиент для заявления рекламации, просим заполнить формуляр рекламации, доступный в пунктах продажи, указывая Рекламационную карту (содержащую дату производства и номер упаковщика или смены упаковки), приложенную к каждому пакету, а также инструкцию по монтажу мебели, на которой просим обозначить поврежденный элемент.
- DE** Reinigen Sie den Möbelbereich nur mit Möbelpflege. Kunden, bei Beanstandung Bitte füllen Sie die Reklamationsformulare, die in den Verkaufsabteilungen erhältlich sind, vor dem Verkauf aus eine Reklamationskarte (mit Angabe des Produktionsdatums und der Anzahl der Personen, die die Waren verpacken, oder der Anzahl der Schichten)Verpackung), die in jeder Packung enthlten ist, und Halterungen, in denen Sie reichlich vorhanden oder beschädigt sind ElementeReinigen Sie den Möbelbereich nur mit Möbelpflege. Kunden, bei Beanstandung.
- GB** Furniture surface must be cleaned only with furniture maintenance formulas.Dear Customer, should you wish to file a complaint, we would request you to fill in the complaint forms available in our outlets, submitting the Complaint Card (specifying the date manufactured, packaging employee/ shift code) enclosed in each of the packets, together with the Assembly Manual, where please highlight the faulty component.
- H** A bútorok felületét kizárólag a bútorápolószerekkel lehet tisztítani. Tisztelt Vásárló! Reklamáció esetén kérjük az eladási helyeken kapható reklamációs nyomtatványokat kitölteni a Reklamációs Lap (tartalmazza a gyártási dátumát és csomagoló számát vagy műszakszámát) bemutatásával, amely mindegyik csomagban található, valamint a bútor szerelési utasítását, amelyen kérjük a sérült elemet bejelölni sziveskedjék.
- FR** La surface des meubles ne peut être nettoyée qu'avec des produits pour l'entretien de meubles. Cher Client, en cas de réclamation, veuillez bien remplir des formulaires de réclamation accessibles dans les centres de vente en montrant le mode d'emploi pour monter le meuble. Nous vous demandons de bien vouloir y entourer l'élément en panne.
- ES** Limpiar la superficie de muebles exclusivamente con los agentes para el cuidado de los muebles.Estimado Cliente, en caso de reclamaciones, hagan favor de rellenar los formularios de reclamación disponibles en los puntos de venta, presentando las instrucciones de montaje de mueble, donde es necesario indicar un elemento estropeado.
- NL** Het oppervlak van meubels hoeft alleen te worden gereinigd door middel van meubelverzorging Beste klant voor de verklaring!
klacht, vul dan het klachtenformulier in dat beschikbaar is in de verkooppunten, met vermelding van: klachtenkaart (bevat de fabricagedatum en het nummer van de verpakker of verandering van verpakking), bevestigd aan elk pakket, evenals instructies voor het installeren van meubels, die we u vragen te markeren beschadigd item.