

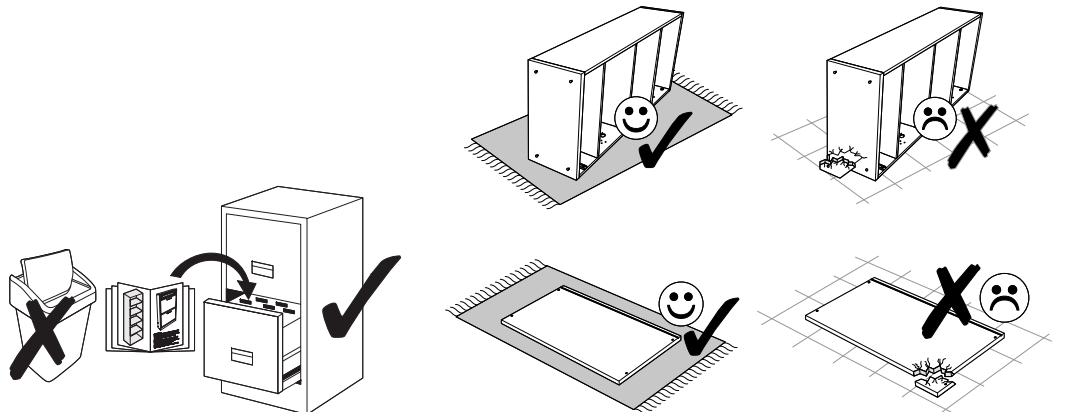

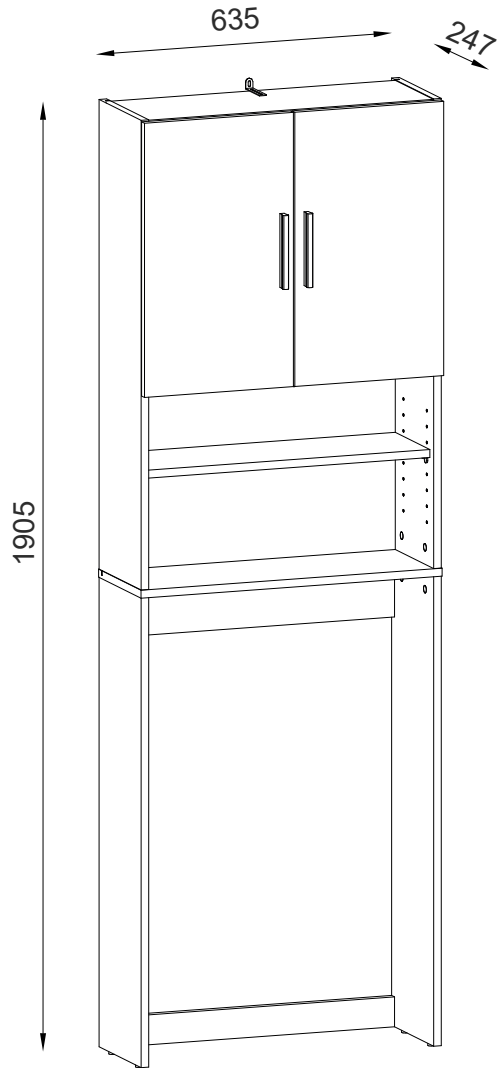

Modell **LAVANA**

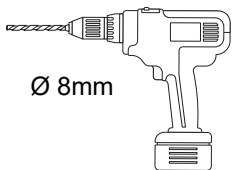

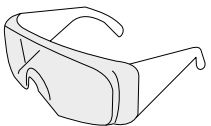
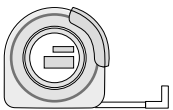
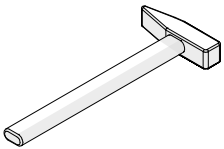
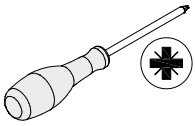
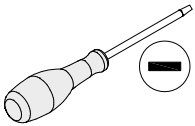
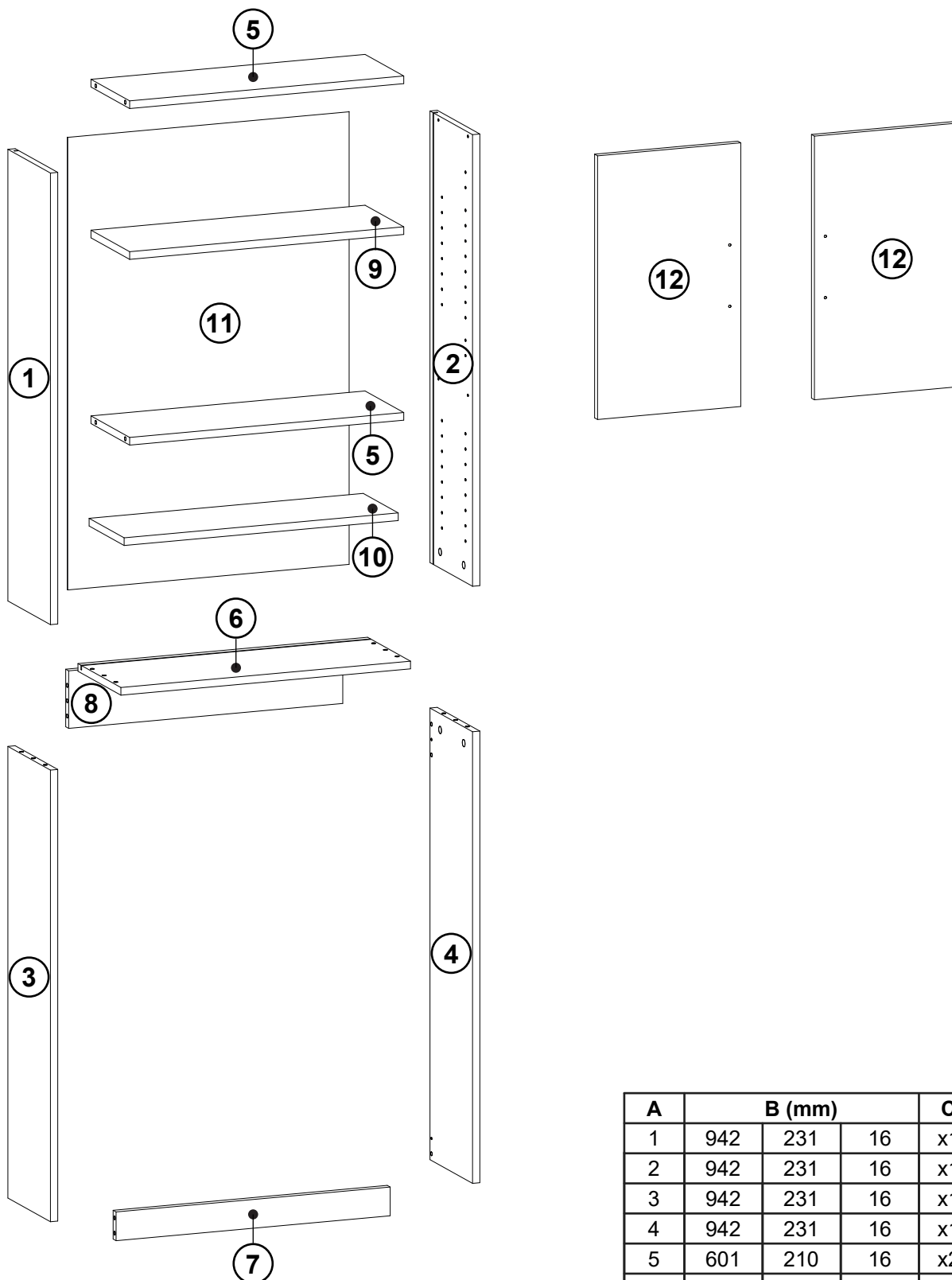

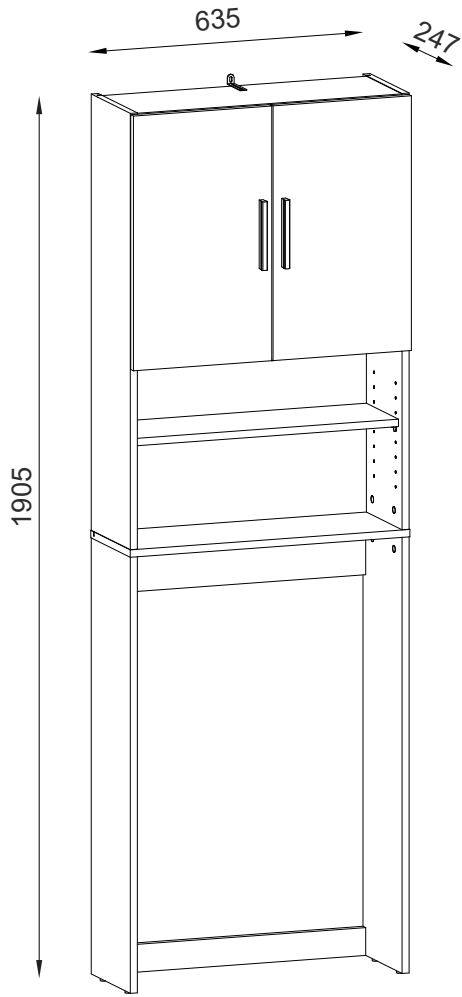



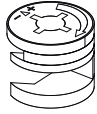
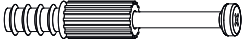
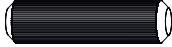

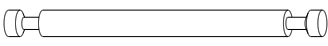
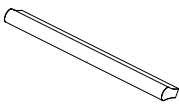
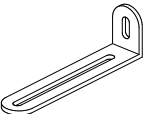
A	B (mm)			C	D
1	942	231	16	x1	1/1
2	942	231	16	x1	1/1
3	942	231	16	x1	1/1
4	942	231	16	x1	1/1
5	601	210	16	x2	1/1
6	635	233	16	x1	1/1
7	601	60	16	x1	1/1
8	601	120	16	x1	1/1
9	601	210	16	x1	1/1
10	601	190	16	x1	1/1
11	944	617	2,5	x1	1/1
12	550	314	16	x2	1/1

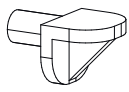
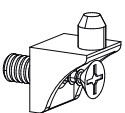
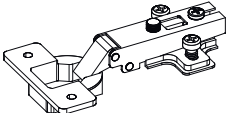

16x		s2
Ø 20mm		
1x		y1
Ø 8x50mm		
20x		r1
Ø 15x12mm		
12x		r23
45mm		
6x		f1
Ø 8x30mm		

2x		f2	4x		r24	2x		c239
Ø 8x50mm			L=84mm			L=128/150mm		
1x		n14/2	4x		k40	4x		d8
L=75x25x15mm			Ø 15mm			Ø 5mm		
4x		d9	4x		ab1	10x		p51
3x10mm			Ø 35mm			Ø 3,5x16mm		
4x		p29	4x		p26	1x		p64
Ø 4,2x19mm			Ø 4x25mm			Ø 4,2x65mm		

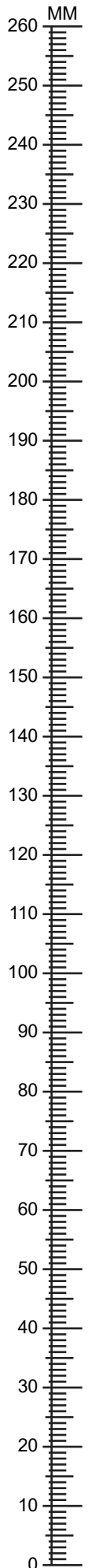

1

r1 x 8



Ø 15x12mm

r23 x 8

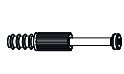

45mm

b2 x 4



40x50x12mm

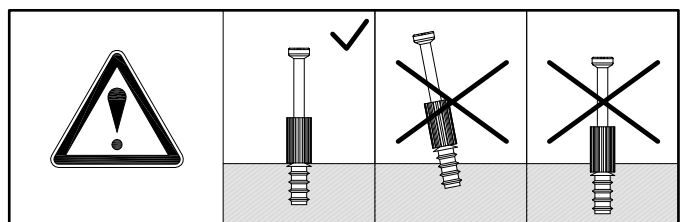
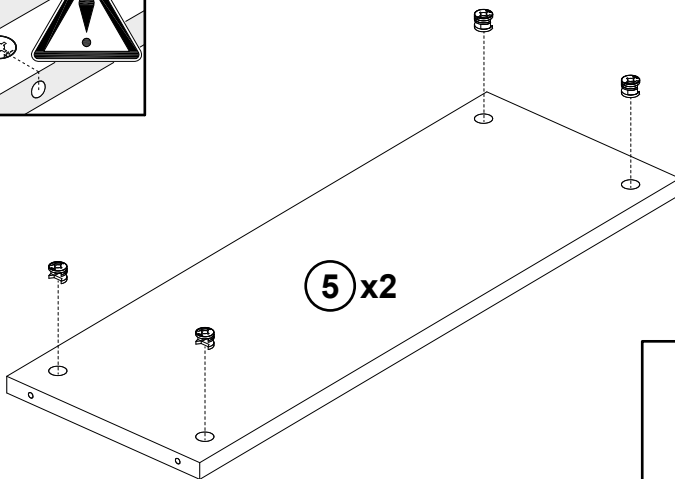
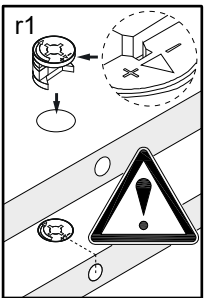
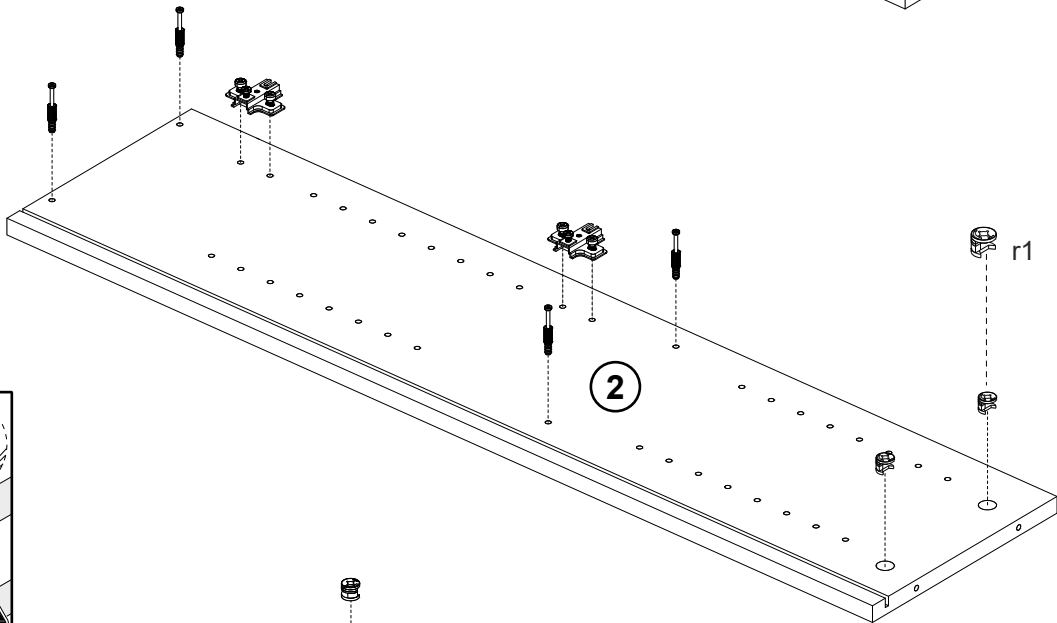
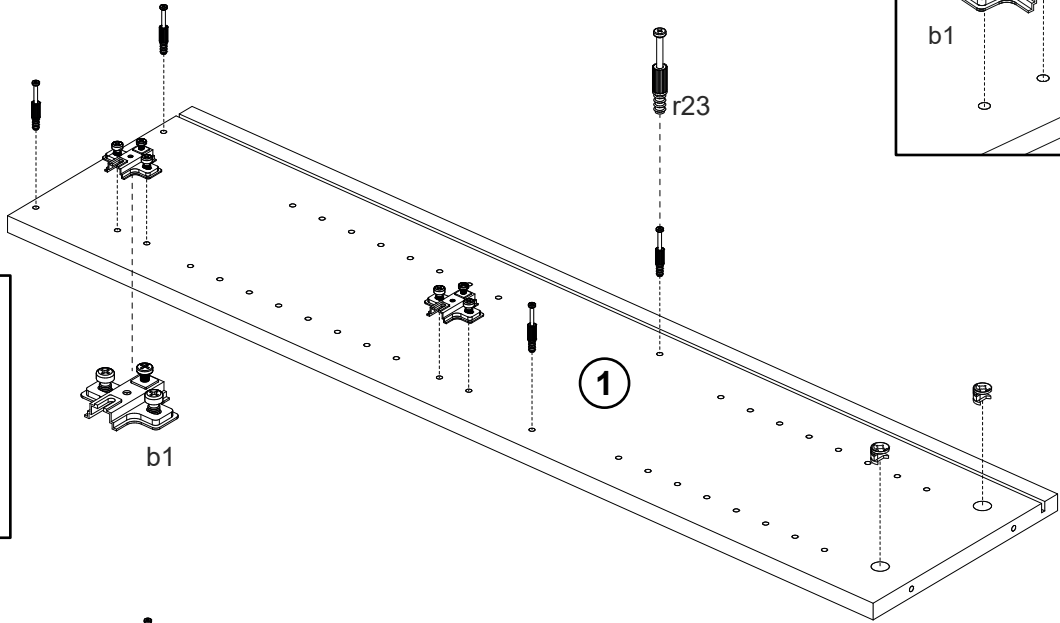
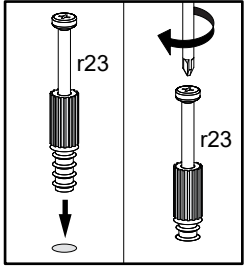
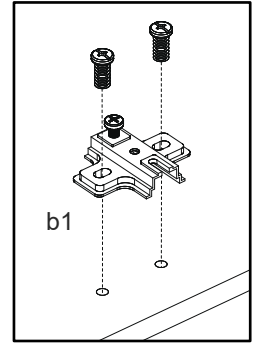
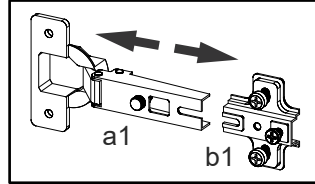



2

r1 x 4
Ø 15x12mm

r23 x 4
45mm

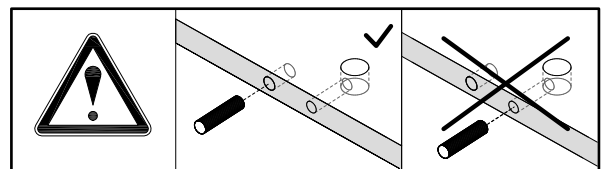
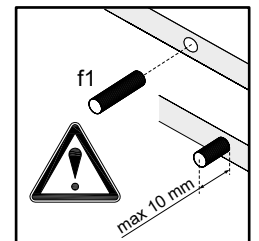
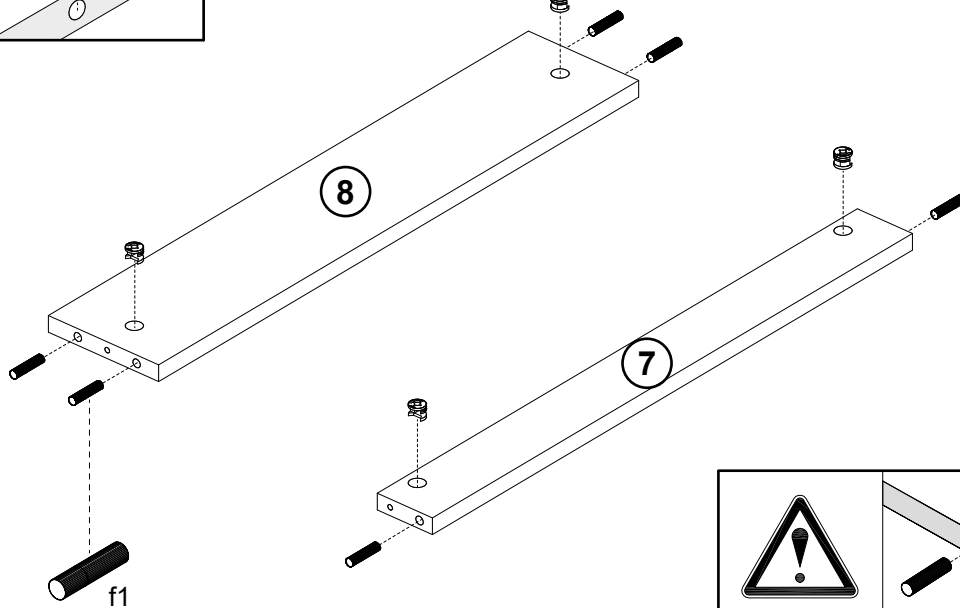
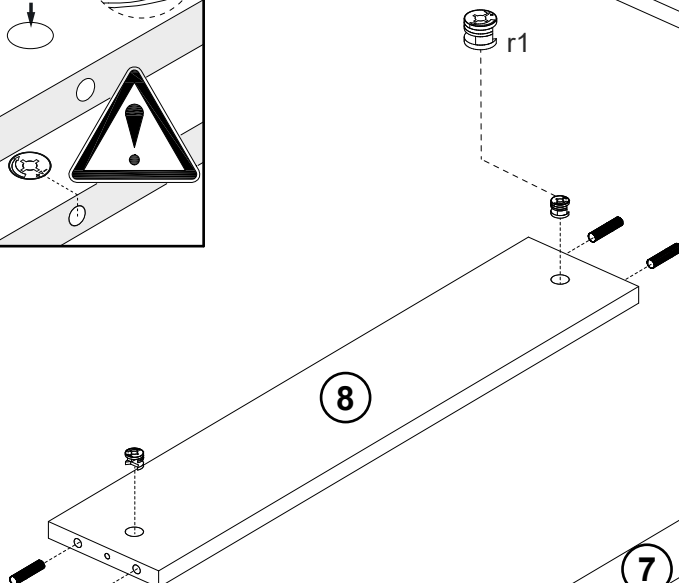
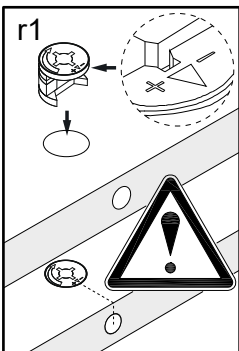
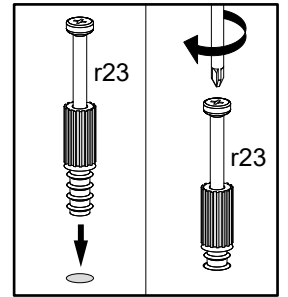
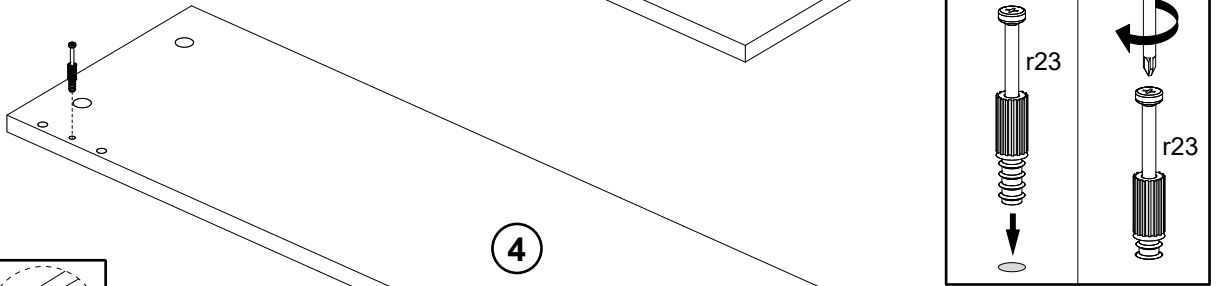
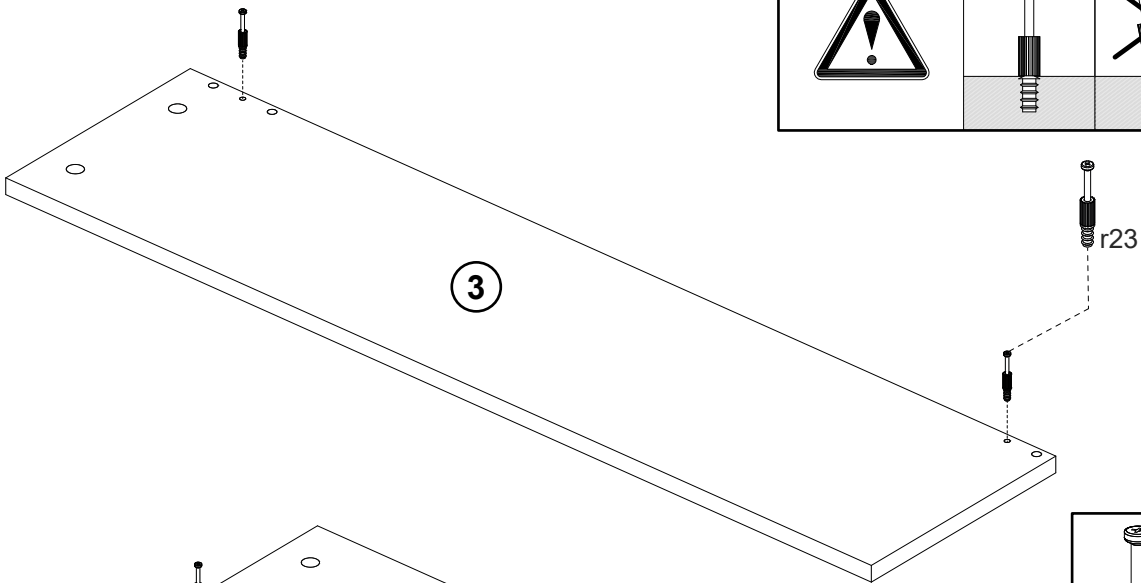
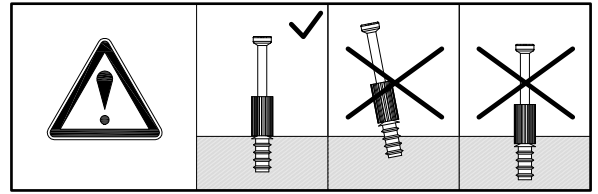
f1 x 6
Ø 8x30mm



3	s2 x 8
	
	Ø 20mm

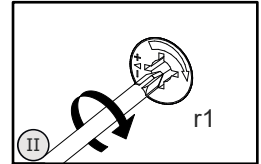
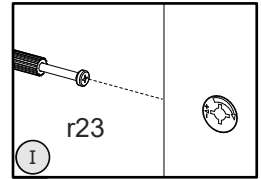
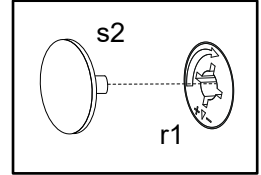
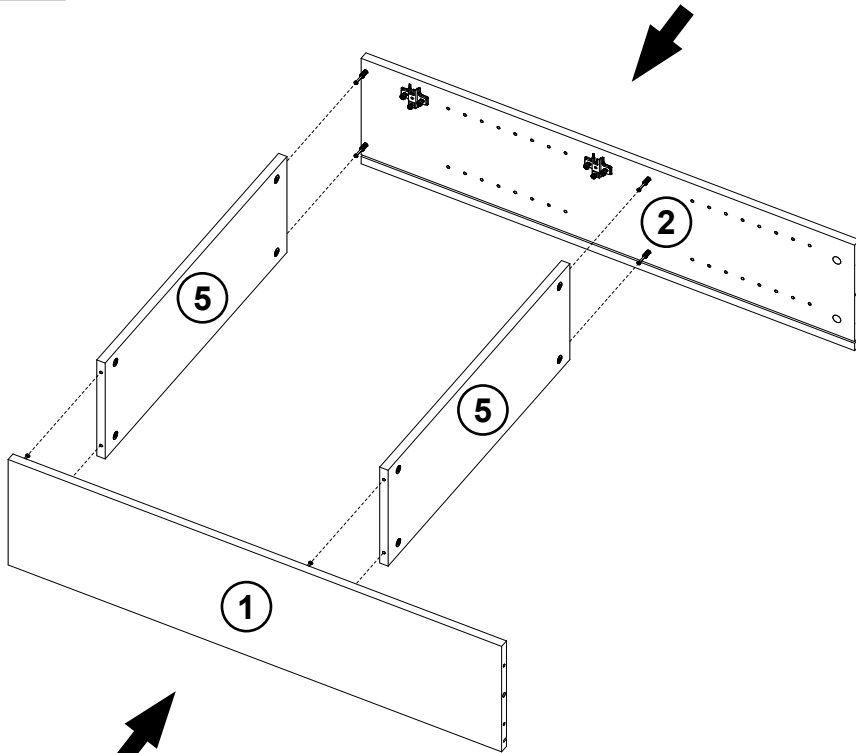

3

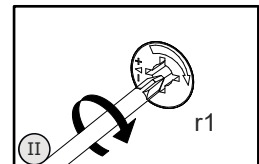
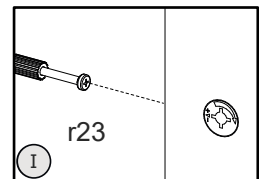
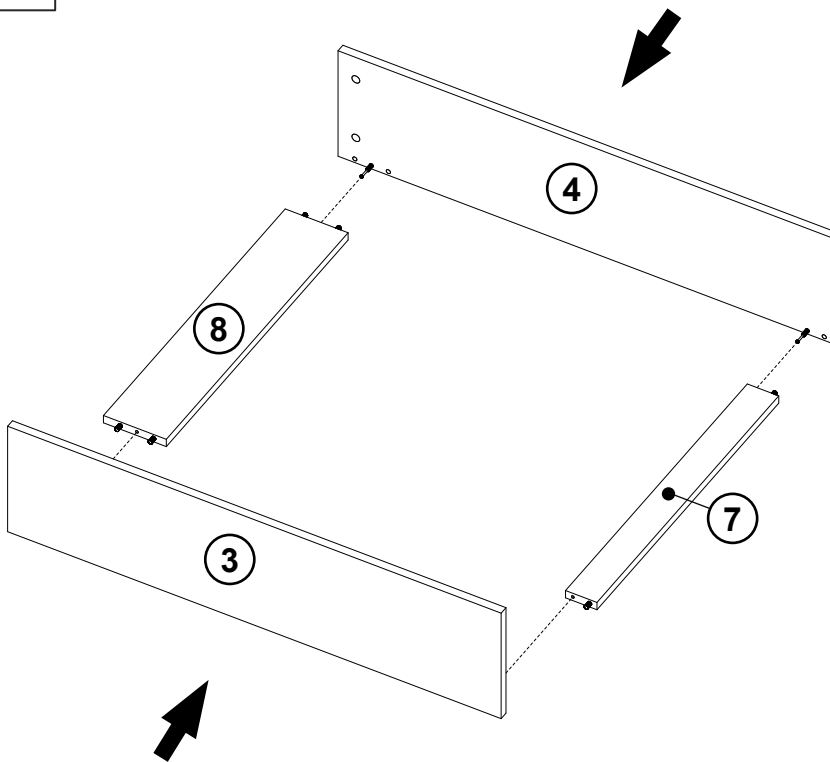

4

f2 x 2



Ø 8x50mm

r24 x 4



L=84mm

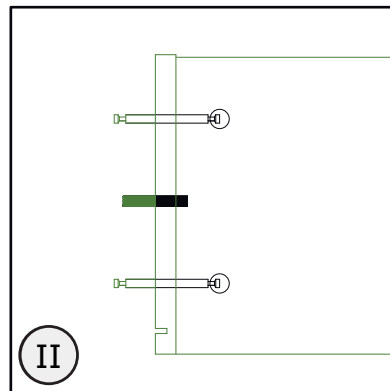
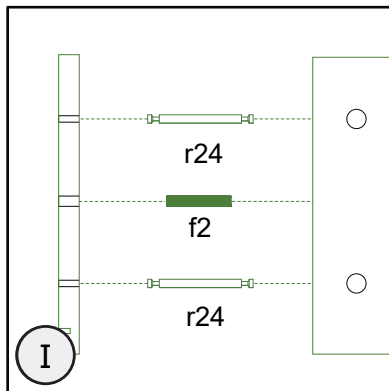
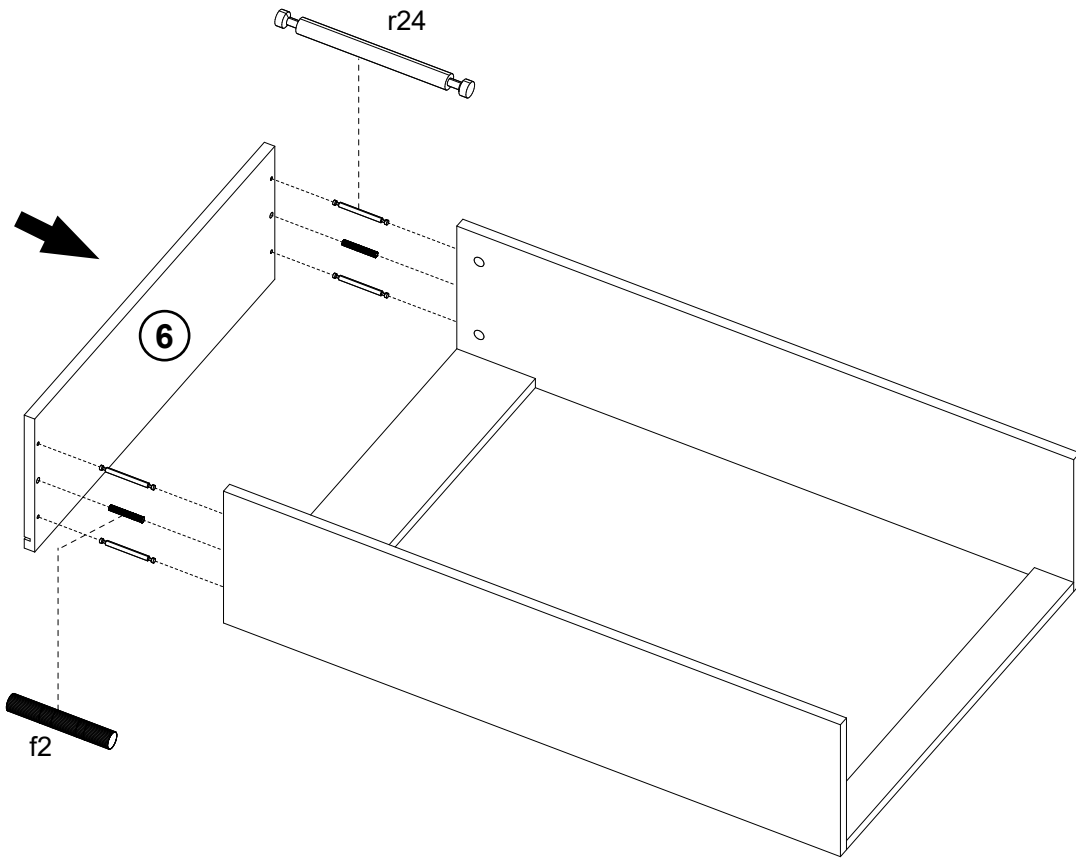

5

r1 x 8



Ø 15x12mm

s2 x 8

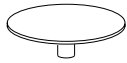

Ø 20mm

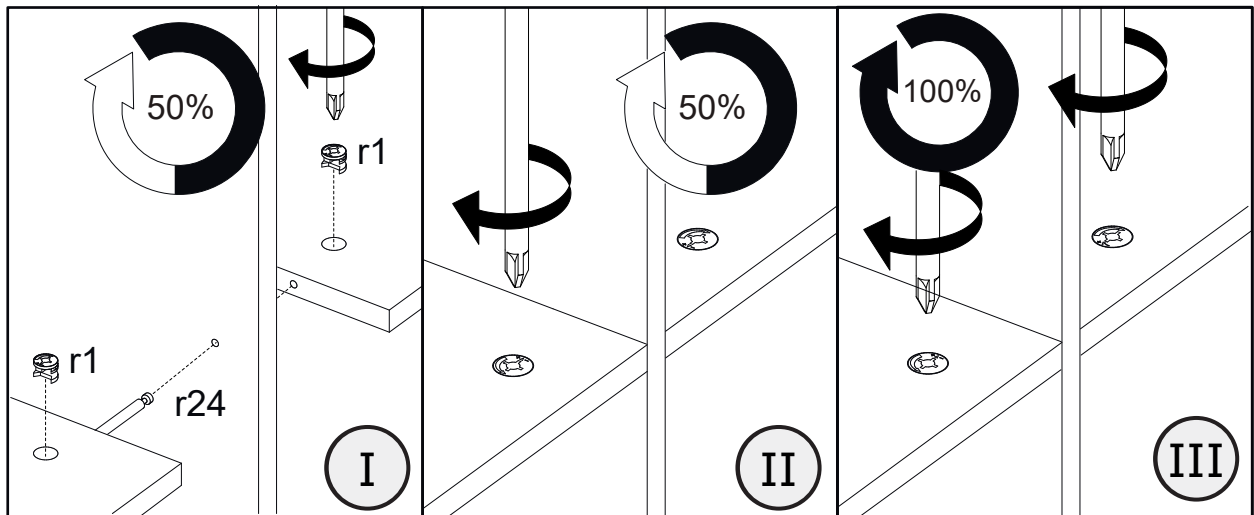
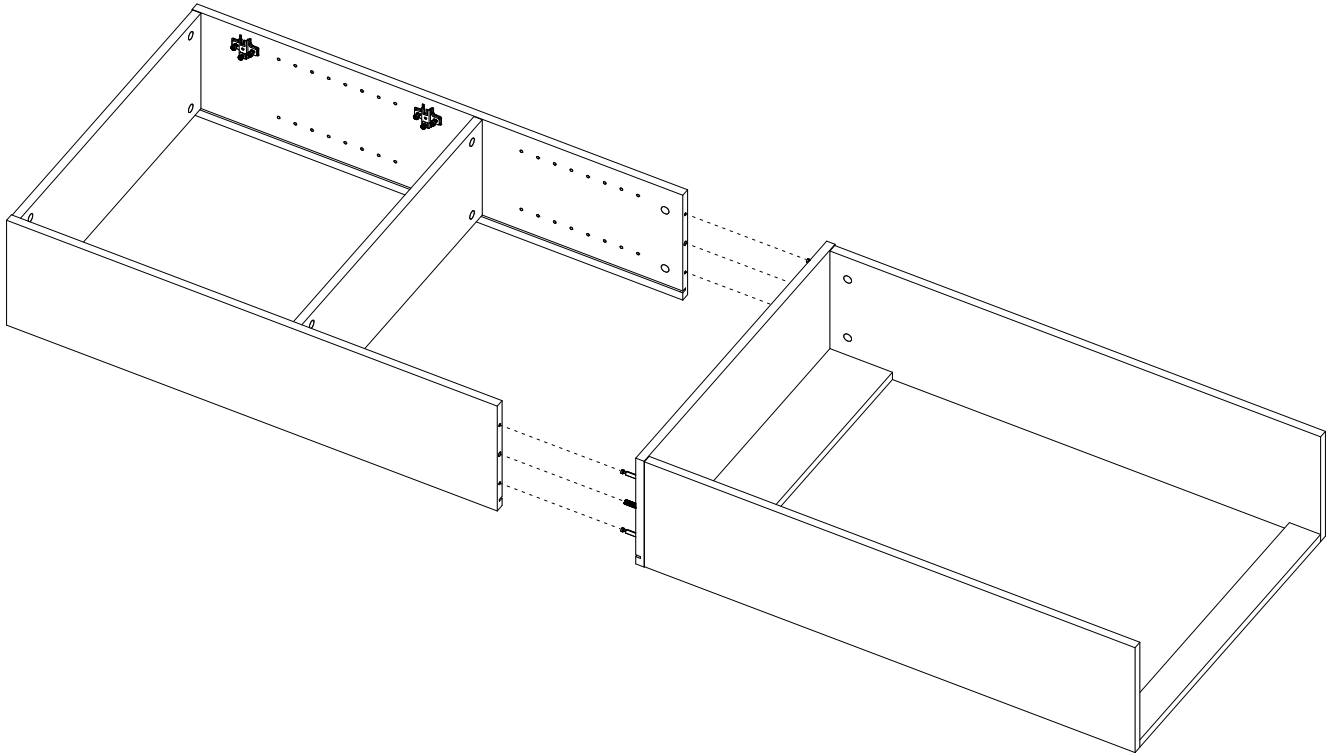

6

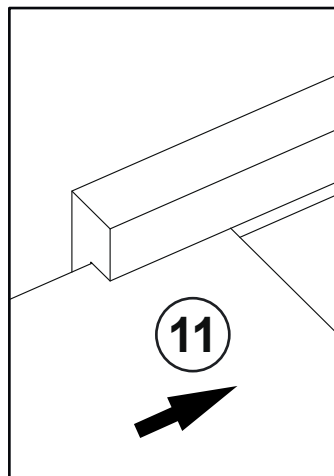
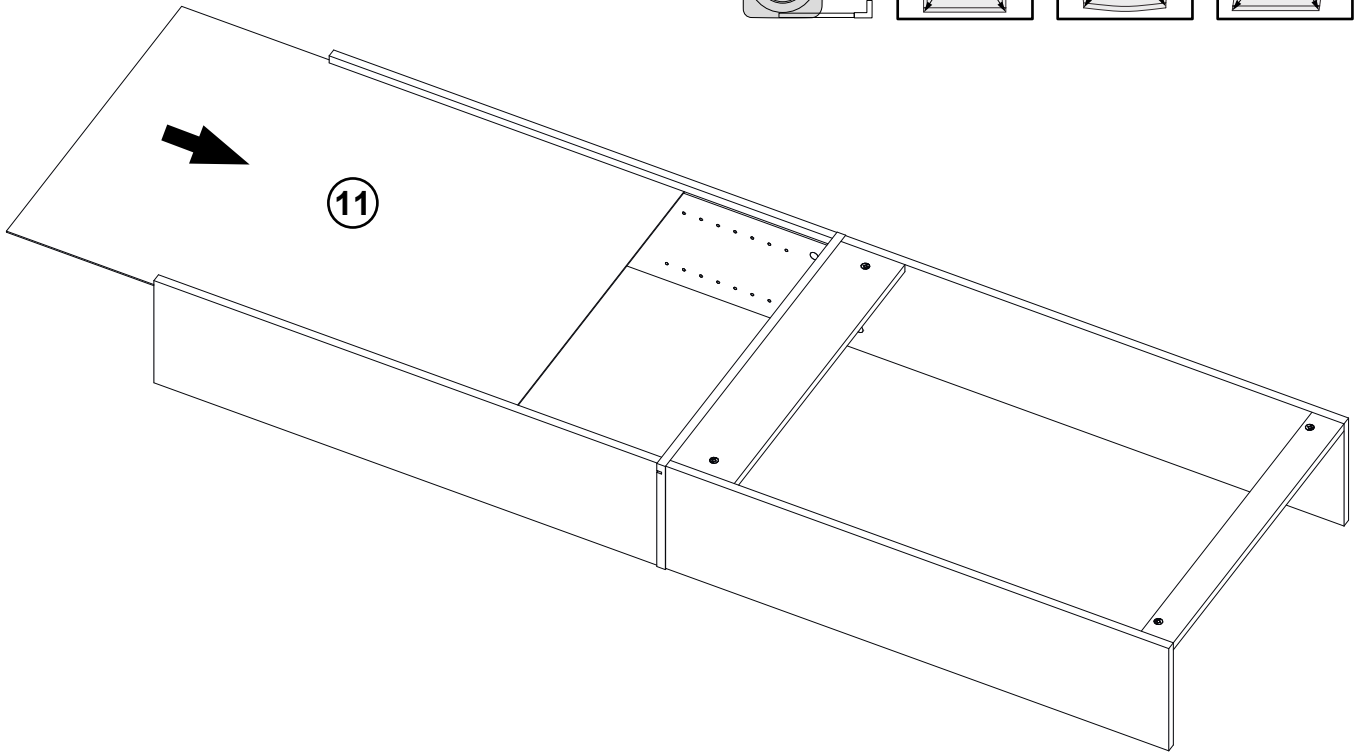
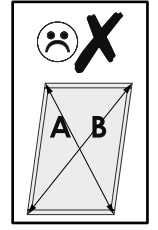
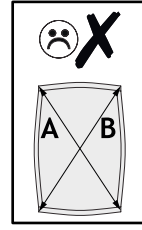
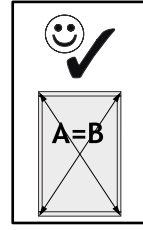

7

k40 x 4



Ø 15mm





p29 x 4

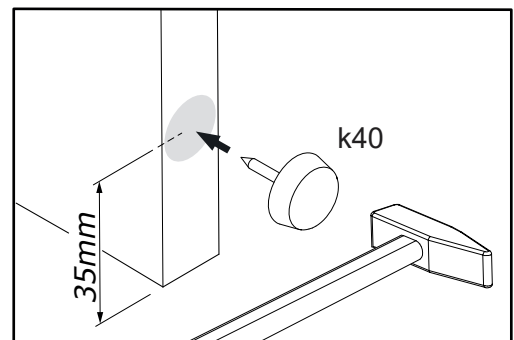
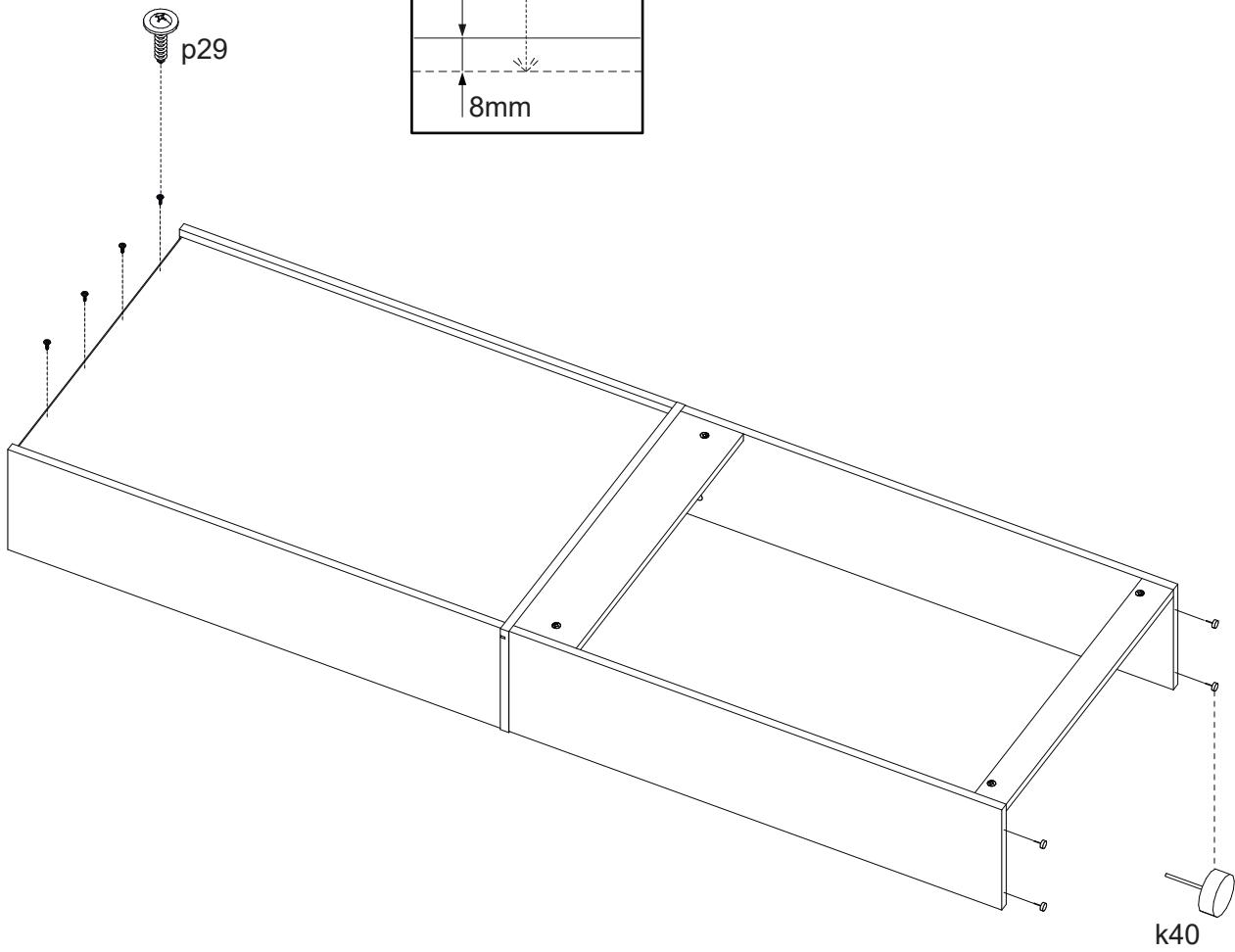
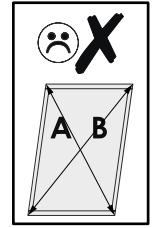
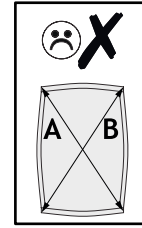
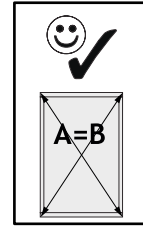
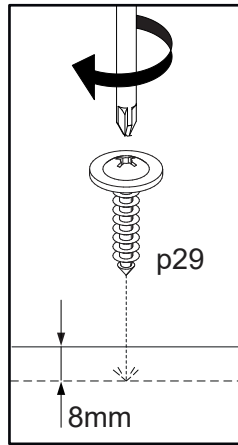

Ø 4,2x19mm

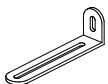

8

n14/2 x 1  L=75x25x15mm	y1 x 1  Ø 8x50mm	p64 x 1  Ø 4,2x65mm	p51 x 2  Ø 3,5x16mm
--	---	--	--

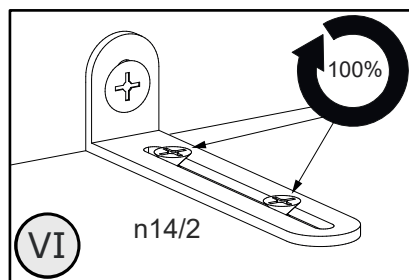
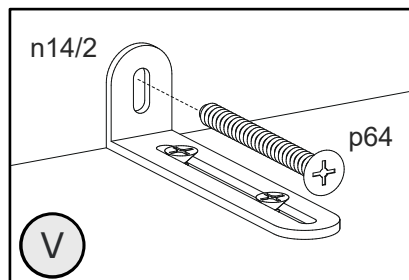
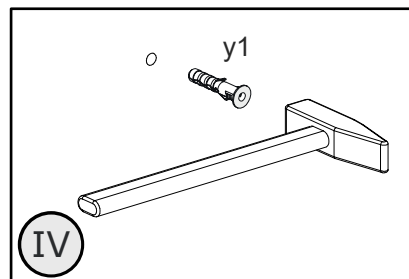
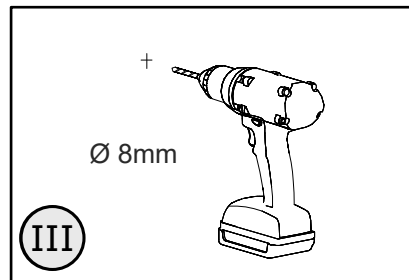
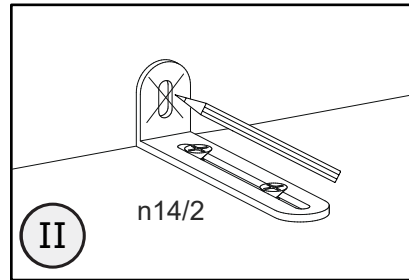
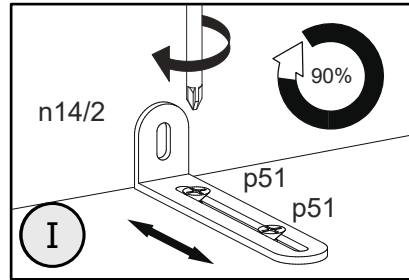
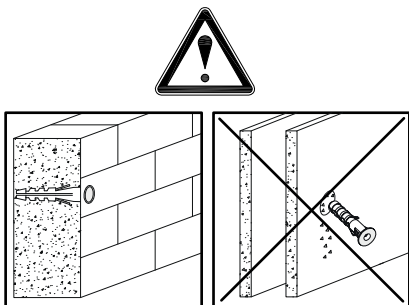
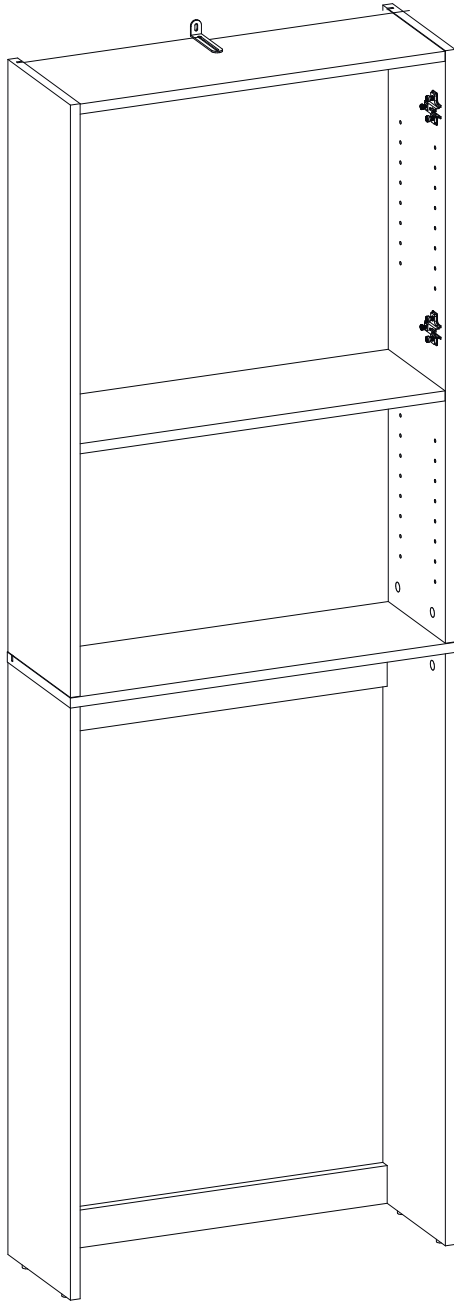

9

d8 x 4

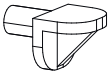

Ø 5mm

d9 x 4



3x10mm

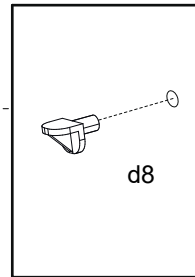
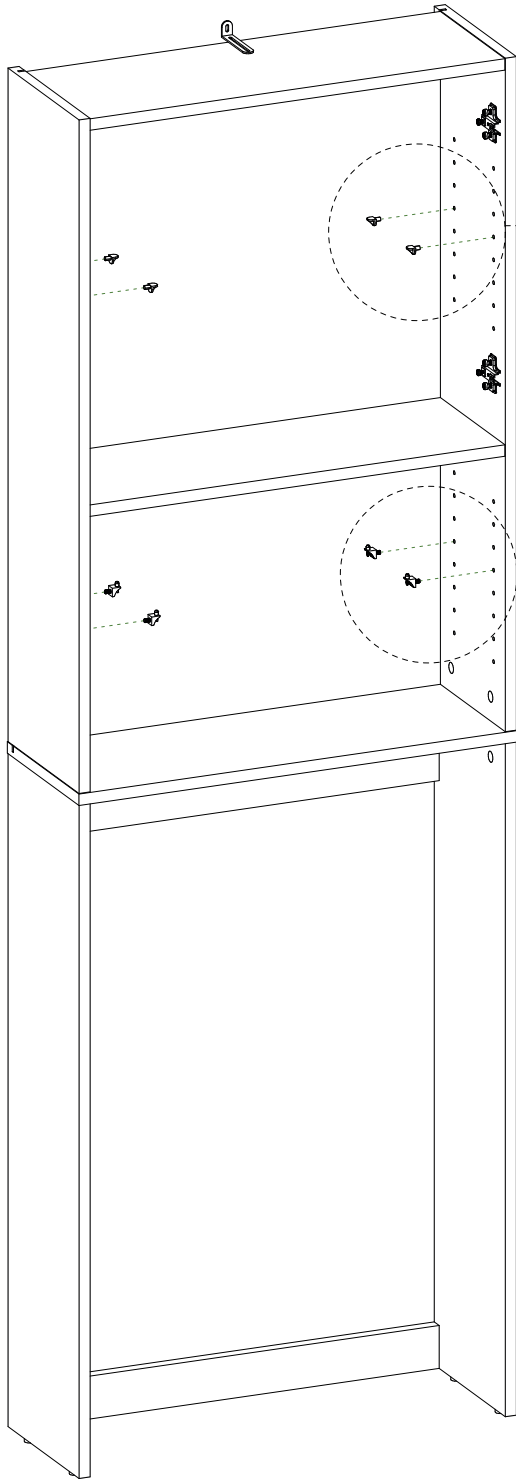

d8

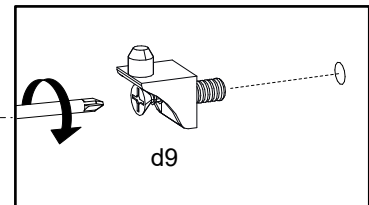

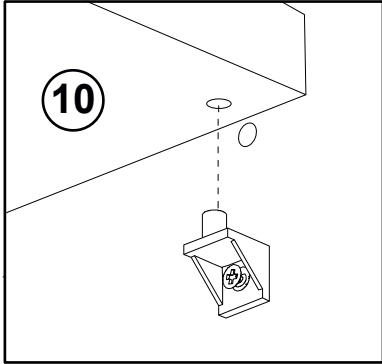
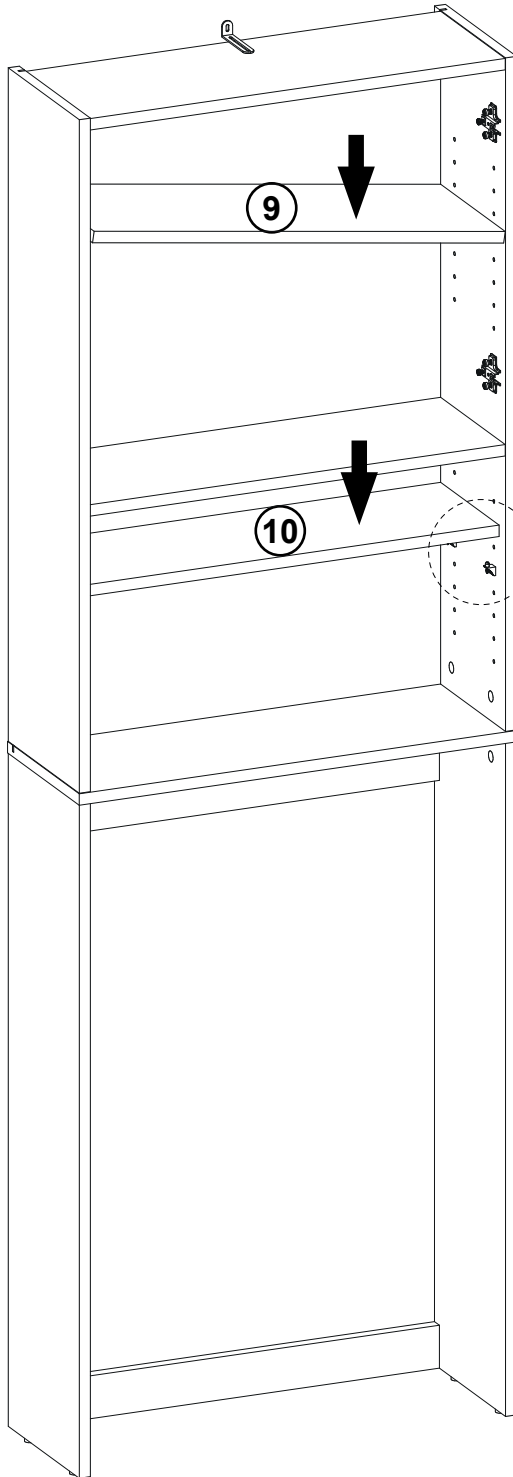

d9

10

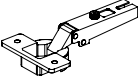

11

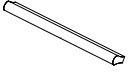
a1 x 4  Ø 35mm	p51 x 8  Ø 3,5x16mm	p26 x 4  Ø 4x25mm	c239 x 2  L=128/150mm
---	--	--	--

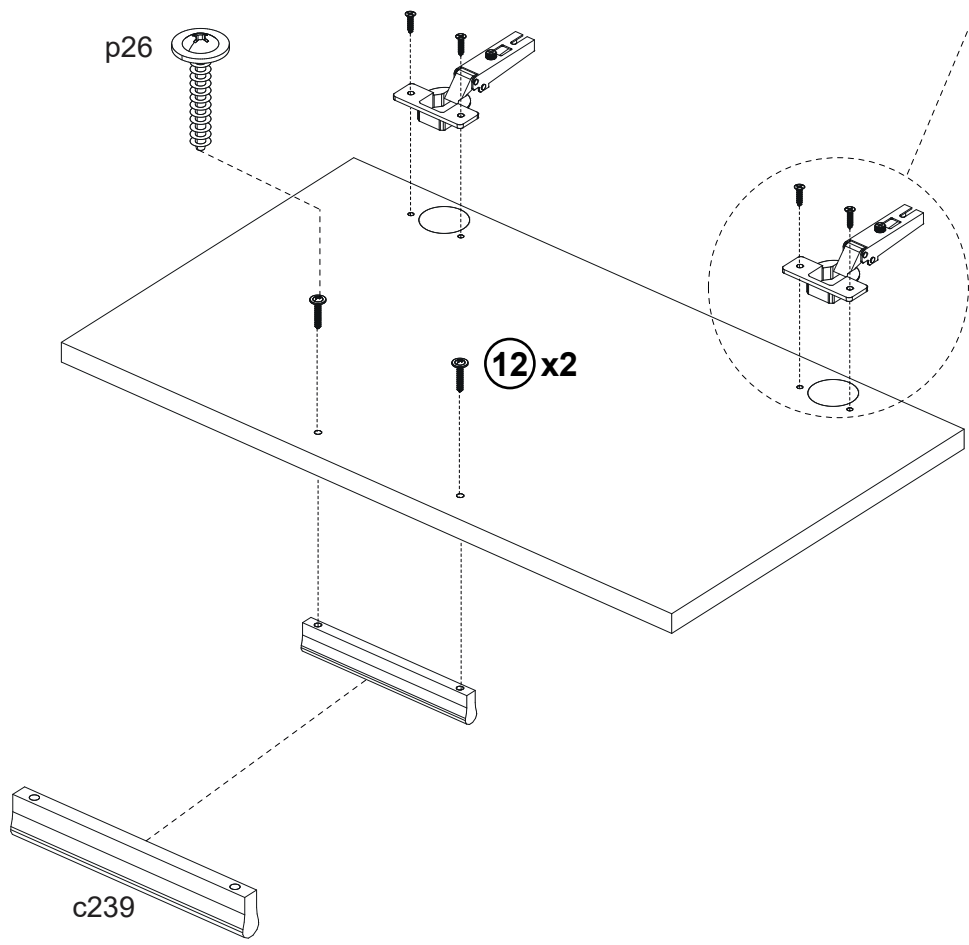
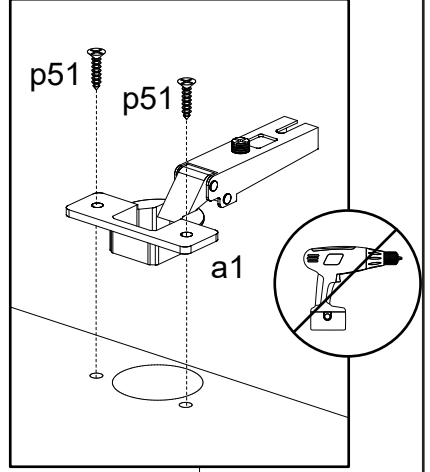
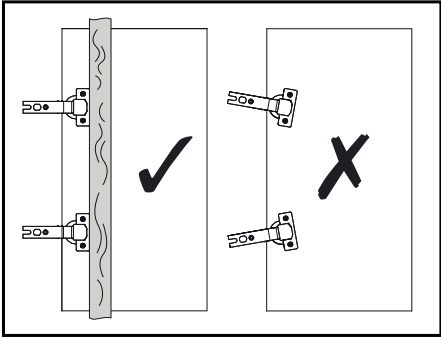

12

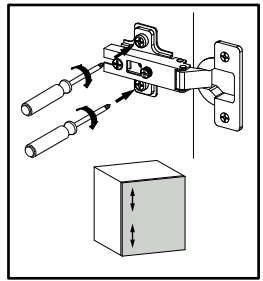
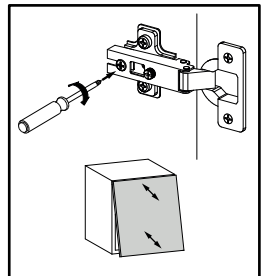
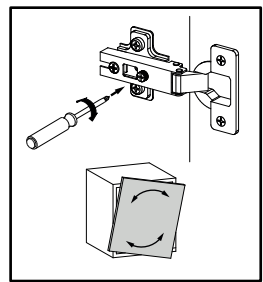
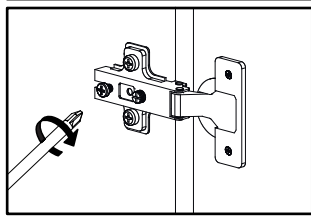
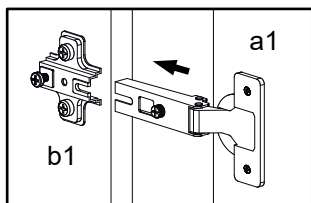
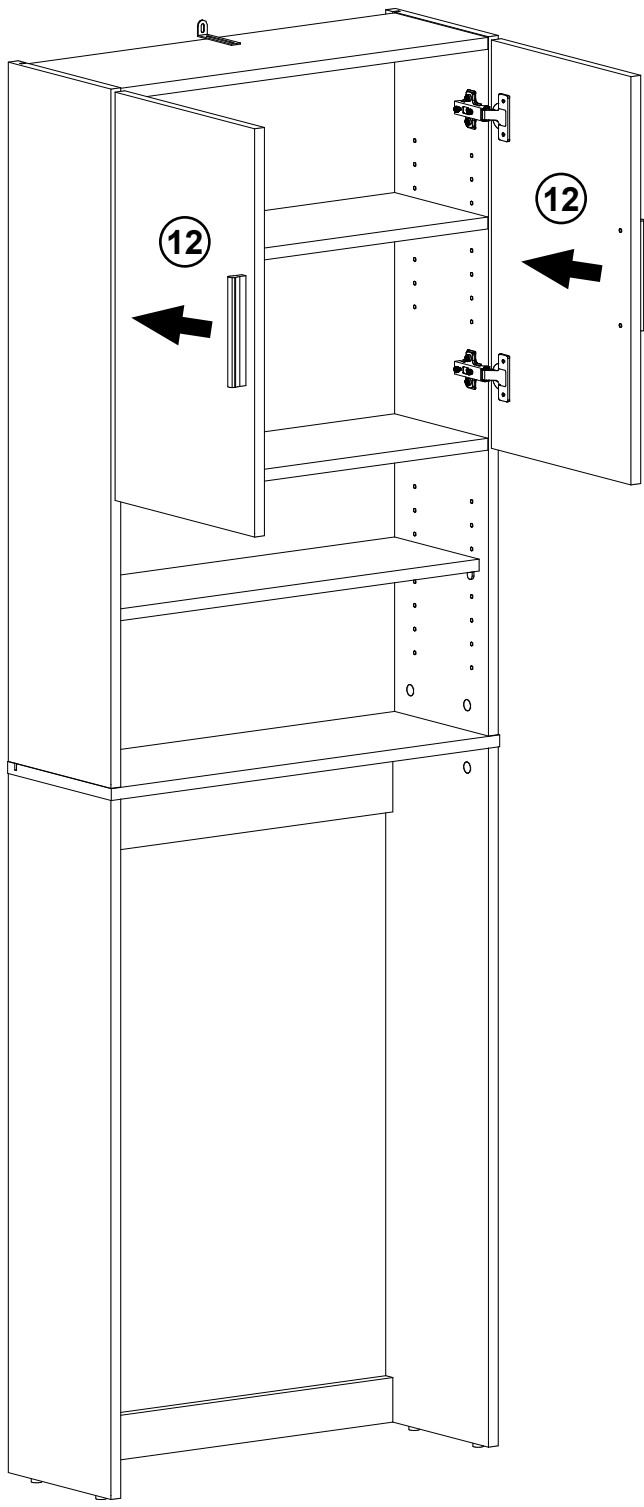

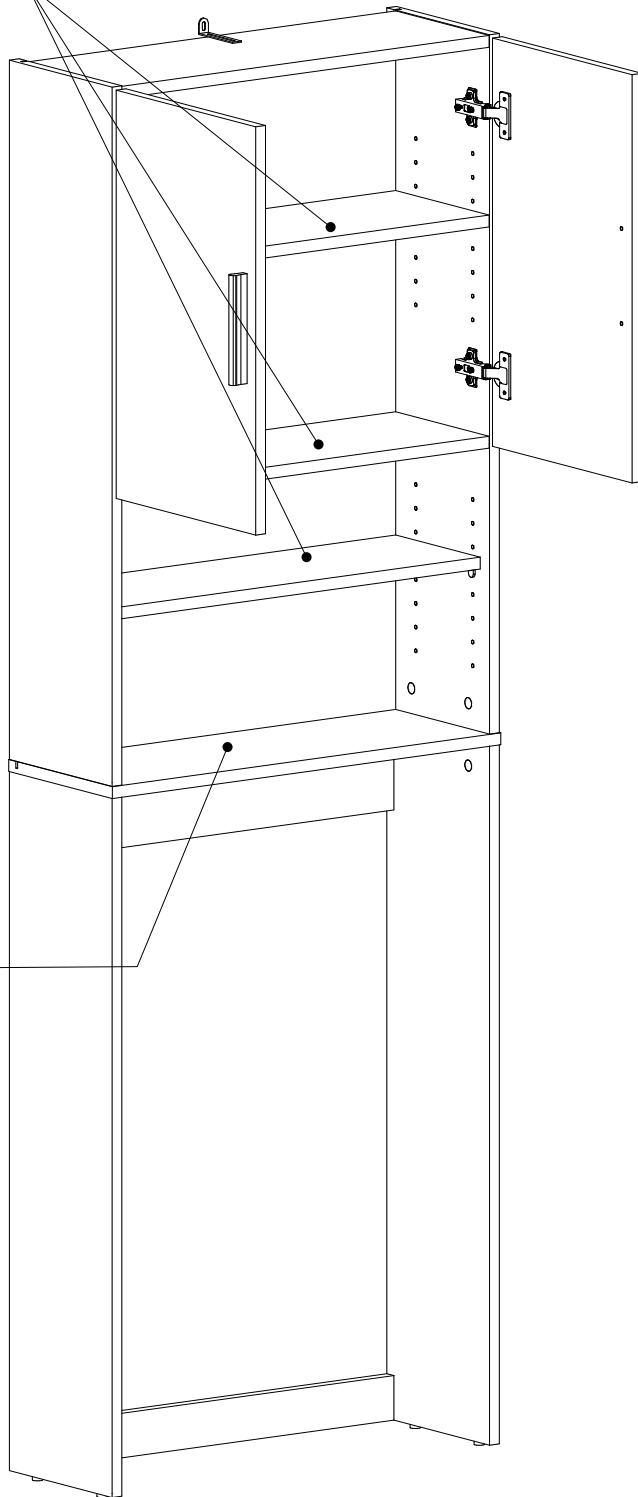

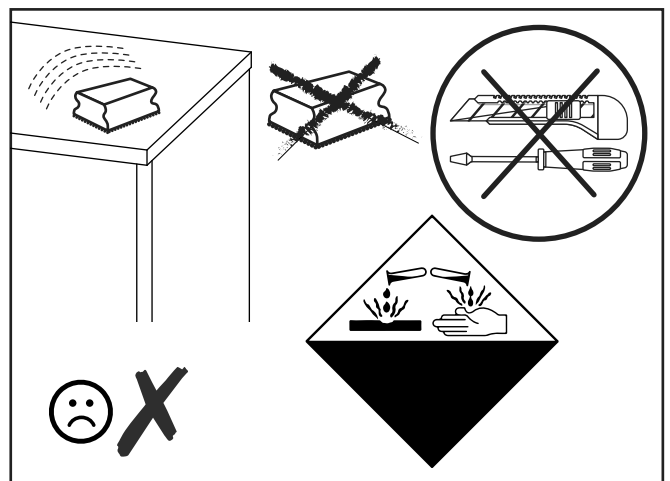
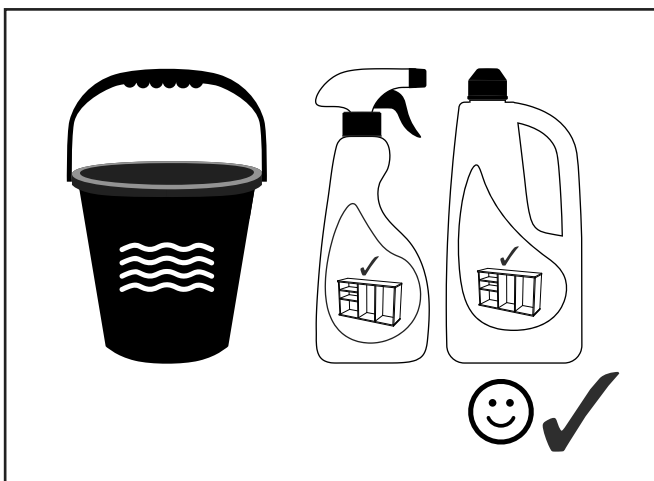
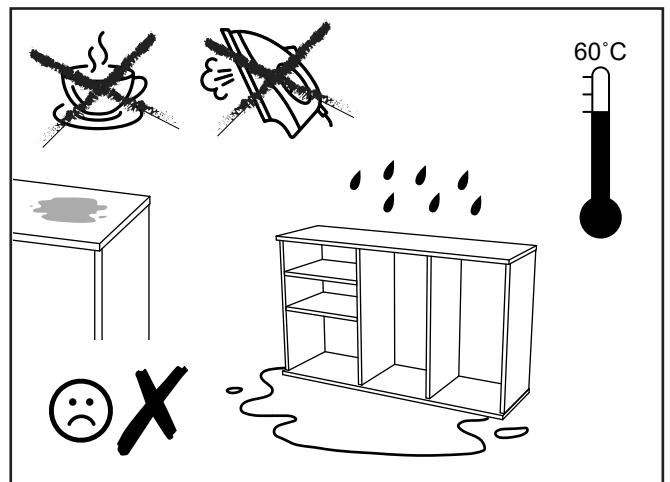
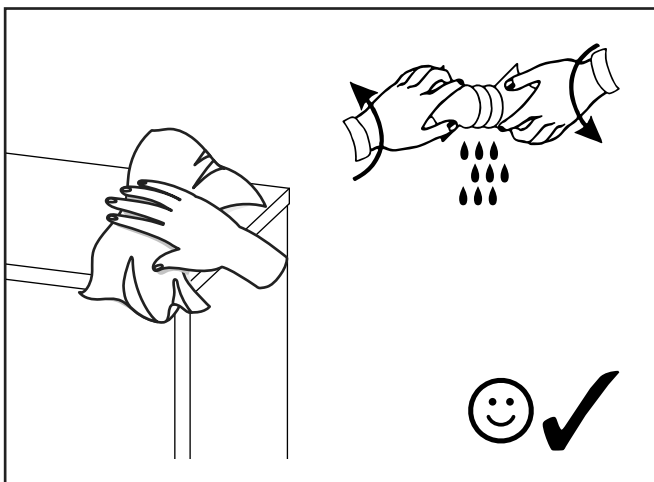
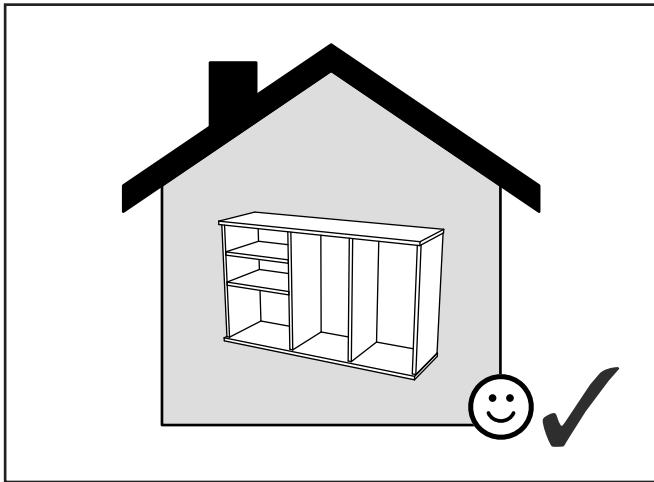

- PL** Powierzchnię mebli należy czyścić tylko środkami do pielęgnacji mebli. Szanowny kliencie w przypadku reklamacji prosimy wypełnić druki reklamacyjne dostępne w punktach sprzedaży przedkładając Kartę Reklamacyjną (zawierającą datę produkcji i numer pakowacza lub zmiany pakowania) umieszczona w każdej z paczek, oraz instrukcję montażu mebla, gdzie prosimy o zaznaczenie uszkodzonego elementu.
- SK** Povrch nábytku čistite iba prostriedkami určenými na ošetrovanie nábytku.Vá ení zákazníci! V prípade reklamácie prosíme, aby ste vyplnili tlačivá, ktoré sú prístupné v obchodoch, predlo ili Reklamačný list (ktorý obsahuje dátum výroby a číslo baliča alebo číslo zmeny pri balení), ktorý sa nachádza v ka dom balení a návod na montáž nábytku, v ktorom označte poškodenú čas.
- CZ** Povrch nábytku čistěte pouze přípravky určenými k ošetřování nábytku.Vá ený zákazník, v případě uplatnění reklamace vyplňte prosím reklamační formuláře, které jsou dostupné v prodejnách a předlo te Reklamační kartu (obsahující datum výroby a číslo balení nebo změny balení, která je umístěna v balíčku) a návod k obsluze s vyznačením poškozeného dílu.
- BG** Повърхността на мебелите трябва да се почиства само с препарати за поддържане на мебели.Уважаеми клиенти, в случай на рекламация моля попълнете формулярите за рекламация, които ще получите в търговските пунктове, като представите Картата за рекламация (съдържаща датата на производство и номера на опаковчика или смяната за опаковане), която ще намерите във всяка опаковка, и инструкцията за монтаж на мебела, върху която да отбележите повредения елемент.
- RO** Suprafața ei trebuie să fie curățată numai cu substanțe destinate pentru curățarea mobilei.Stimate Cumpărător, în caz de reclamație vă rugăm să completați formularul de reclamație pe care îl puteți lua de la punctul de vânzare și pe care îl veți prezenta împreună cu Cartela de Garanție (care conține data producției și nr ambalatorului sau turei de ambalare), însoțită la fiecare ambalaj, precum și instrucțiunile de montaj ale mobilei, pe care vă rugăm să marcați elementul deteriorat.
- UA** Поверхню меблів потрібно чистити тільки засобами для догляду за меблями.Шановний клієнте для заяви рекламачії, просимо заповнити формуляр рекламачії, доступний у пунктах продажу, вказуючи рекламачійну карту (містить дату виробництва та номер пакувальника або зміни упаковки), прикладену до кожного пакету, а також інструкцію з монтажу меблів, на якій просимо позначити пошкоджений елемент.
- RUS** Поверхность мебели надо чистить только средствами для ухода за мебелью.Уважаемый клиент для заявления рекламации, просим заполнить формуляр рекламации, доступный в пунктах продажи, указывая Рекламационную карту (содержащую дату производства и номер упаковщика или смены упаковки), приложенную к каждому пакету, а также инструкцию по монтажу мебели, на которой просим обозначить поврежденный элемент.
- DE** Reinigen Sie den Möbelbereich nur mit Möbelpflege. Kunden, bei Beanstandung Bitte füllen Sie die Reklamationsformulare, die in den Verkaufsabteilungen erhältlich sind, vor dem Verkauf aus eine Reklamationskarte (mit Angabe des Produktionsdatums und der Anzahl der Personen, die die Waren verpacken, oder der Anzahl der Schichten)Verpackung), die in jeder Packung enthlten ist, und Halterungen, in denen Sie reichlich vorhanden oder beschädigt sind ElementeReinigen Sie den Möbelbereich nur mit Möbelpflege. Kunden, bei Beanstandung.
- GB** Furniture surface must be cleaned only with furniture maintenance formulas.Dear Customer, should you wish to file a complaint, we would request you to fill in the complaint forms available in our outlets, submitting the Complaint Card (specifying the date manufactured, packaging employee/ shift code) enclosed in each of the packets, together with the Assembly Manual, where please highlight the faulty component.
- H** A bútorok felületét kizárólag a bútorápolószerekkel lehet tisztítani. Tisztelt Vásárló! Reklamáció esetén kérjük az eladási helyeken kapható reklamációs nyomtatványokat kitölteni a Reklamációs Lap (tartalmazza a gyártási dátumát és csomagoló számát vagy műszakszámát) bemutatásával, amely mindegyik csomagban található, valamint a bútor szerelési utasítását, amelyen kérjük a sérült elemet bejelölni sziveskedjék.
- FR** La surface des meubles ne peut être nettoyée qu'avec des produits pour l'entretien de meubles. Cher Client, en cas de réclamation, veuillez bien remplir des formulaires de réclamation accessibles dans les centres de vente en montrant le mode d'emploi pour monter le meuble. Nous vous demandons de bien vouloir y entourer l'élément en panne.
- ES** Limpiar la superficie de muebles exclusivamente con los agentes para el cuidado de los muebles.Estimado Cliente, en caso de reclamaciones, hagan favor de rellenar los formularios de reclamación disponibles en los puntos de venta, presentando las instrucciones de montaje de mueble, donde es necesario indicar un elemento estropeado.
- NL** Het oppervlak van meubels hoeft alleen te worden gereinigd door middel van meubelverzorging Beste klant voor de verklaring!
klacht, vul dan het klachtenformulier in dat beschikbaar is in de verkooppunten, met vermelding van: klachtenkaart (bevat de fabricagedatum en het nummer van de verpakker of verandering van verpakking), bevestigd aan elk pakket, evenals instructies voor het installeren van meubels, die we u vragen te markeren beschadigd item.