

finori GmbH
Straßäcker 2
D - 96253 Untersiemau

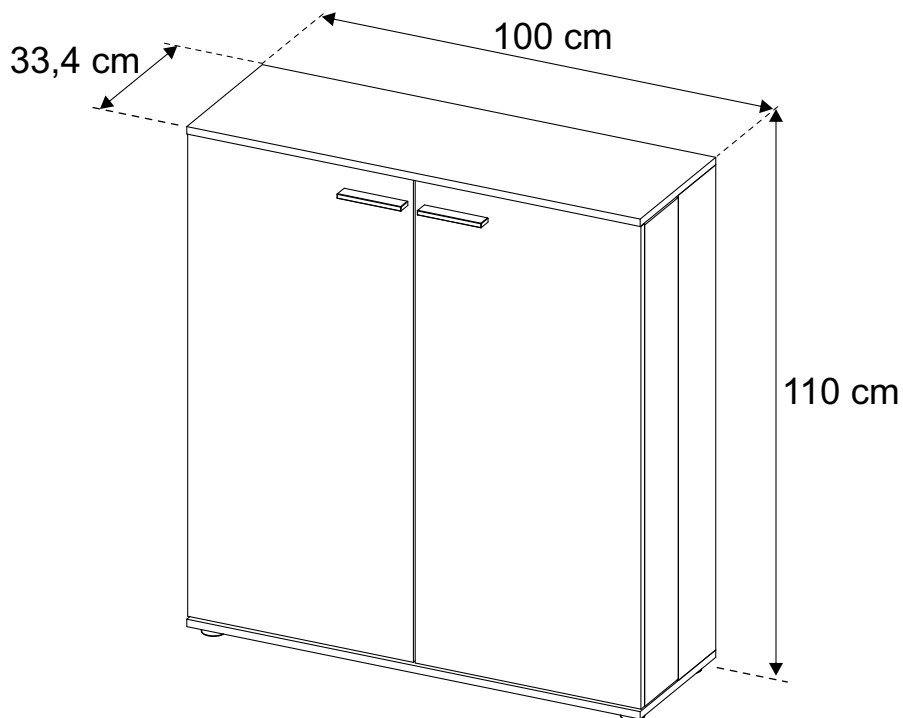

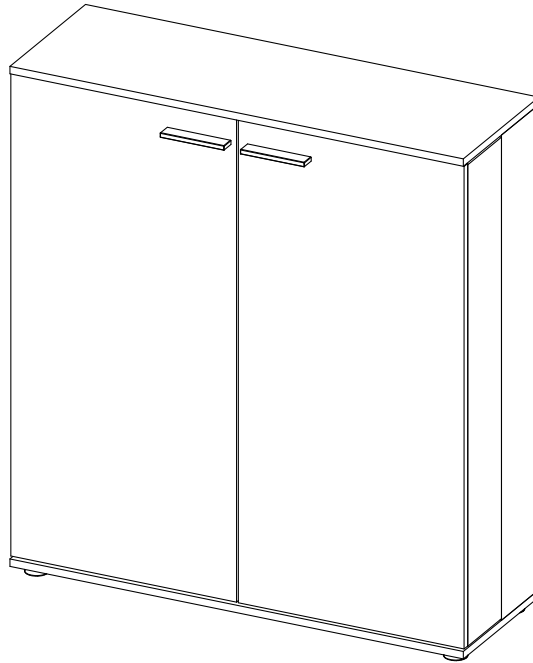
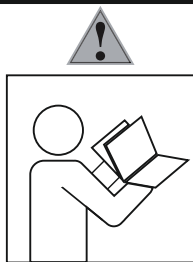

- Ⓓ Befolgen Sie stets die Anleitung des Herstellers!
- ⒸⒹ Please generally follow the manufacturers instructions!
- ⒻⒺ Suivez toujours les instructions du fabricant!
- ⒶⒹ Volg steeds de handleiding van de producent!
- ⒺⒶ Siga siempre las instrucciones del fabricante!
- ⒶⒹ Stale przestrzegaj instrukcji producenta!

- ⒶⒹ Всегда следуйте инструкции производителя!
- ⒶⒹ Seguire sempre le istruzioni del produttore!
- ⒶⒹ Mindig tartsa be a gyártó utasításait!
- ⒶⒹ Siga sempre as instruções do fabricante!
- ⒶⒹ Vždy dodržujte pokyny výrobce!
- ⒶⒹ Vždy dodržujte pokyny výrobcu!

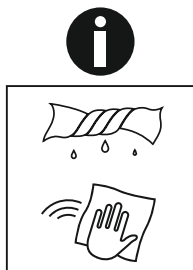

- Ⓓ Verwenden Sie zur Reinigung nur ein feuchtes Tuch!
- ⒸⒹ Please only clean with a damp cloth!
- ⒻⒺ N'utilisez qu'un chiffon humide pour le nettoyage!
- ⒶⒹ Gebruik voor de reiniging enkel een vochtige doek!
- ⒺⒶ Para limpiar utilice sólo un paño húmedo!
- ⒶⒹ Do czyszczenia używaj wilgotnej szmatki!

- ⒶⒹ Для очистки используйте только влажную ткань!
- ⒶⒹ Per la pulizia, utilizzare solo un panno umido!
- ⒶⒹ A tisztításhoz elegendő egy nedves kendő használatát!
- ⒶⒹ Para a limpeza use apenas um pano húmido!
- ⒶⒹ Pro čištění používejte pouze vlhký hadřík!
- ⒶⒹ Na čistenie používajte iba vlhkú handričku!

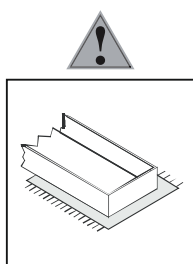

- Ⓓ Bauen Sie das Produkt auf einer Unterlage auf!
- ⒸⒹ Please mount the product on a bottom support!
- ⒻⒺ Montez le produit sur une base!
- ⒶⒹ Monteer het product op een basis!
- ⒺⒶ Monte el producto sobre una base!
- ⒶⒹ Rozkładaj produkt na podkładce!

- ⒶⒹ Собирайте изделие на подстилке!
- ⒶⒹ Montare il prodotto su un supporto!
- ⒶⒹ Az összeszereléskor helyezzen a termék alá megfelelő alátétet!
- ⒶⒹ Monte o produto numa superfície plana!
- ⒶⒹ Výrobek smontujte na pevném podkladu!
- ⒶⒹ Výrobok zmontujte na pevnom podklade!

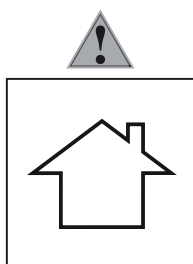

- Ⓓ Verwenden Sie das Produkt nur in Innenräumen!
- ⒸⒹ Please exclusively use the product indoors!
- ⒻⒺ N'utilisez le produit qu'à l'intérieur!
- ⒶⒹ Gebruik het product enkel binnenshuis!
- ⒺⒶ Utilice el producto sólo en interiores!
- ⒶⒹ Używaj produkt tylko w pomieszczeniach wewnętrznych!

- ⒶⒹ Используйте изделие только во внутренних помещениях!
- ⒶⒹ Utilizzare il prodotto solo in ambienti interni!
- ⒶⒹ A termék csak bel terekben használható!
- ⒶⒹ Use o produto apenas no interior!
- ⒶⒹ Používejte výrobek pouze uvnitř!
- ⒶⒹ Výrobok používajte len vo vnútri!

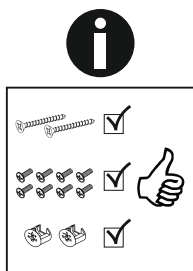

- Ⓓ Legen Sie die Beschläge zusammen und prüfen Sie die Vollständigkeit!
- ⒸⒹ Please join the fittings and verify their completeness!
- ⒻⒺ Pliez les raccords ensemble et vérifiez qu'ils sont complets!
- ⒶⒹ Leg de onderdelen samen en controleer de volledigheid!
- ⒺⒶ Junte los accesorios y compruebe que están todos!
- ⒶⒹ Rozłóż poszczególne części i sprawdź kompletność!

- ⒶⒹ Положите фурнитуру в одно место и проверьте комплектность!
- ⒶⒹ Mettere insieme le guarnizioni e verificarne la completezza!
- ⒶⒹ Állítsa össze a sarokvasakat, és ellenőrizze, hogy épek-e!
- ⒶⒹ Coloque os encaixes juntos e verifique se estão completos!
- ⒶⒹ Složte armatury a zkontrolujte úplnost!
- ⒶⒹ Zložte armatúry a zkontrolujte úplnosť!

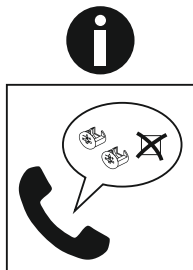

- Ⓓ Bei fehlenden Teilen kontaktieren Sie den Hersteller!
- ⒸⒹ If parts are missing, please turn to the manufacturer!
- ⒻⒺ En cas de pièces manquantes, veuillez contacter le fabricant!
- ⒶⒹ Contacteer de fabrikant als er onderdelen ontbreken!
- ⒺⒶ En el caso de que falten piezas, póngase en contacto con el fabricante!
- ⒶⒹ W razie braku części skontaktuj się z producentem!

- ⒶⒹ При отсутствии каких-либо частей обратитесь к производителю!
- ⒶⒹ In caso di pezzi mancanti, contattare il produttore!
- ⒶⒹ Ha hiányozna valamelyik elem, lépjen kapcsolatba a gyártóval!
- ⒶⒹ Em caso de peças em falta, entre em contato com o fabricante!
- ⒶⒹ Pro chybějící díly kontaktujte výrobce!
- ⒶⒹ Ak vám chýbajú diely kontaktujte výrobcu!

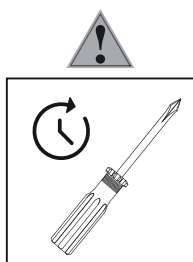

- Ⓓ Ziehen Sie die Schrauben nach einiger Zeit des Gebrauchs erneut fest!
- ⒸⒹ Please re-tighten the screws after having used the product for a while!
- ⒻⒺ Resserrer les vis après un certain temps utilisation!
- ⒶⒹ Draai de schroeven na een zekere gebruikstijd opnieuw vast!
- ⒺⒶ Asegure de nuevo los tornillos tras usarlo durante un tiempo!
- ⒶⒹ Po pewnym czasie użytkowania ponownie dokręć śruby!

- ⒶⒹ Спустя некоторое время использования подкрутите гайки!
- ⒶⒹ Stringere nuovamente le viti dopo un certo periodo di utilizzo!
- ⒶⒹ A használat során némi idő elteltével húzza meg újra a csavarokat!
- ⒶⒹ Reaperte os parafusos após algum tempo de uso!
- ⒶⒹ Po určité době používání rouby znovu utáhněte!
- ⒶⒹ Po určitej dobe používania skrutky znovu utiahnite!

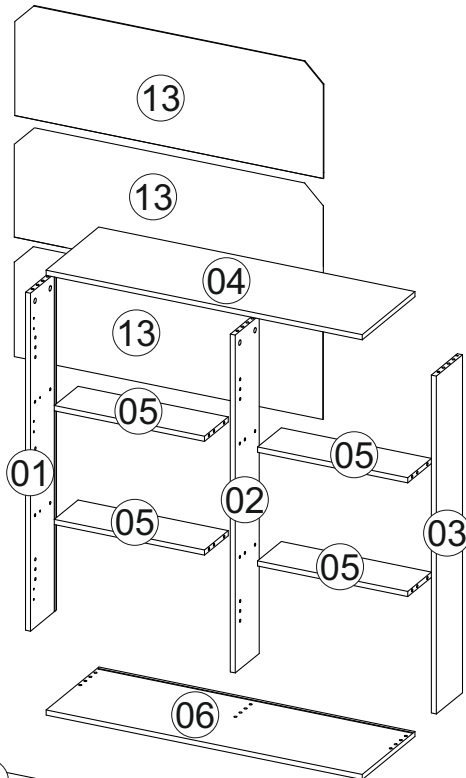
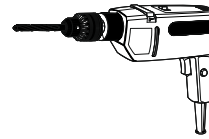
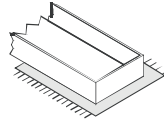
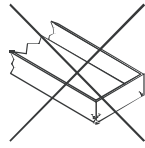
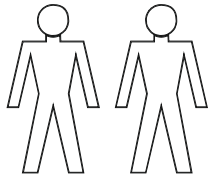
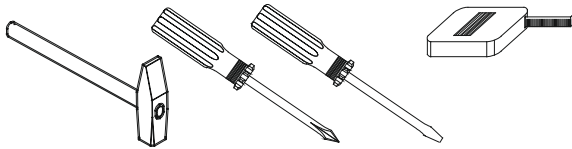

Dimensions / Abmessung in mm/		
①	1 x	1048x165x16
②	1 x	1048x151x16
③	1 x	1048x165x16
④	1 x	1000x334x16
⑤	4 x	475x150x16
⑥	1 x	1000x334x16
⑦	1 x	1042x498x16
⑧	1 x	1042x498x16
⑨	1 x	1040x149x16
⑩	2 x	1040x149x16
⑪	8 x	464x148x16
⑫	1 x	1040x149x16
⑬	3 x	976x352x3

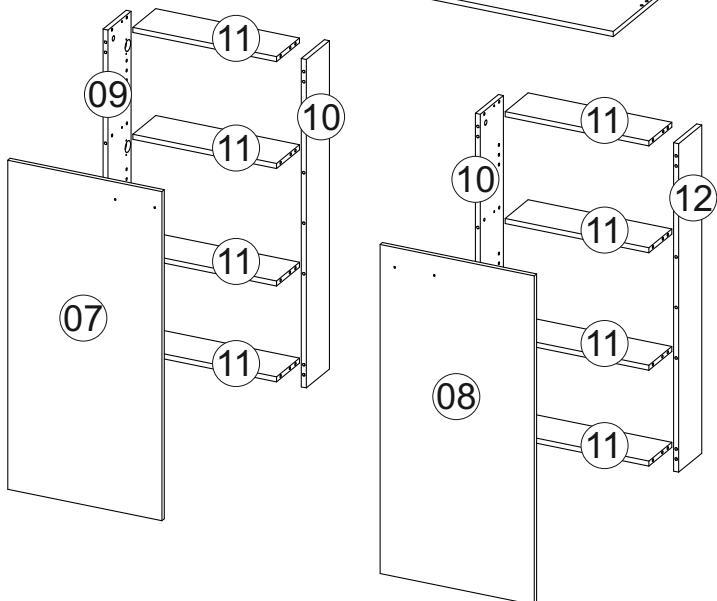

BOX 1	4x05; 1x07; 1x08; 8x11; 3x13;
BOX 2	1x01; 1x02; 1x03; 1x04; 1x06; 1x09; 2x10; 1x12;

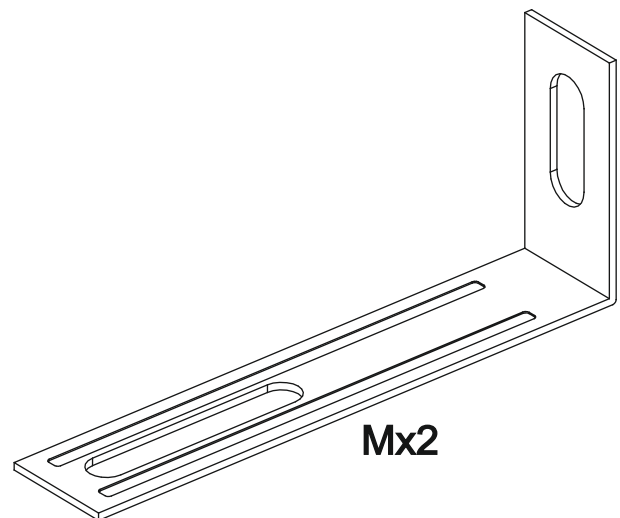
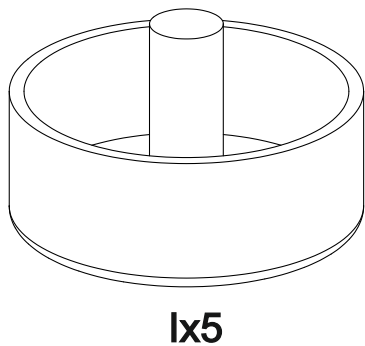
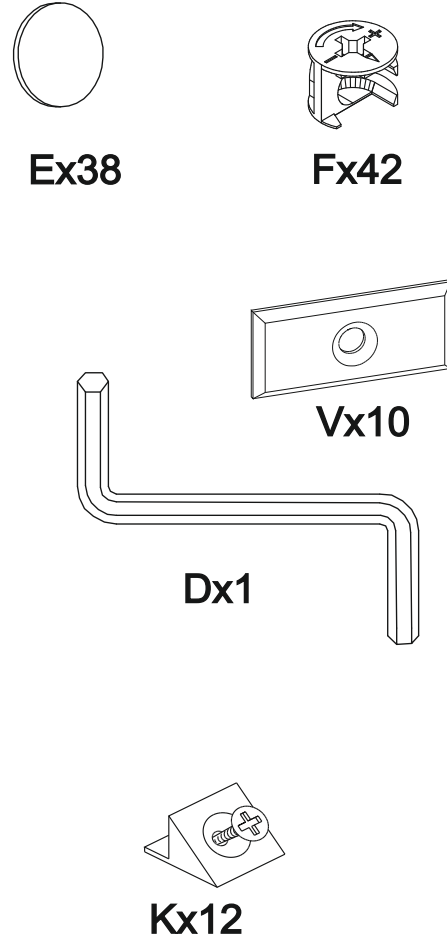
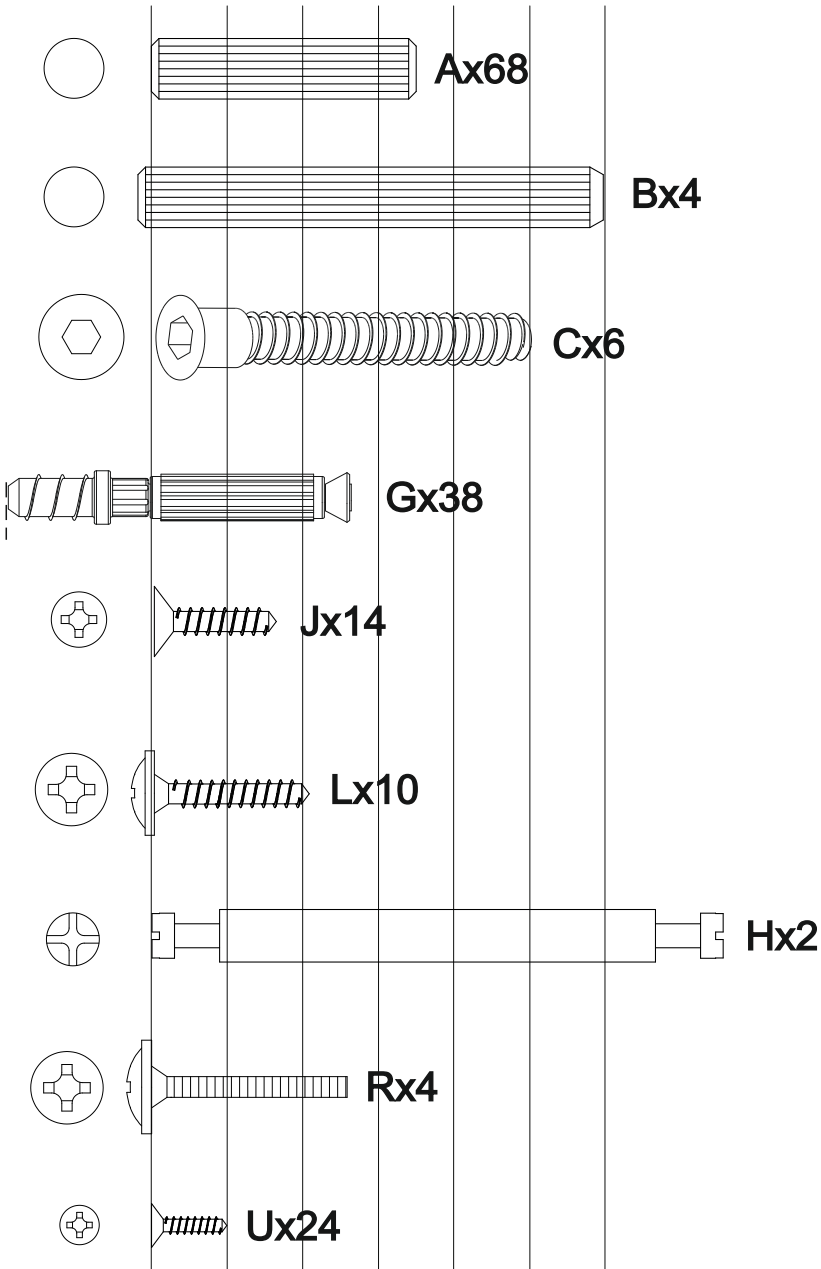
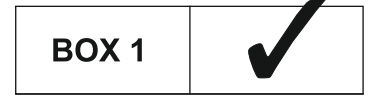
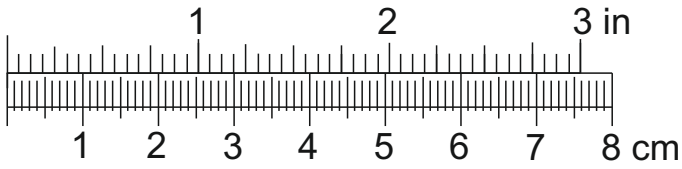

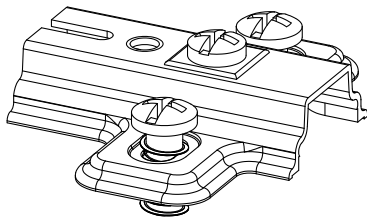
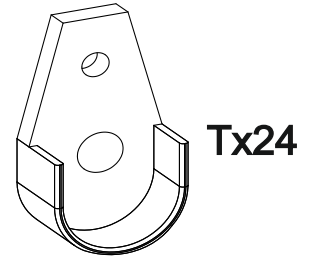
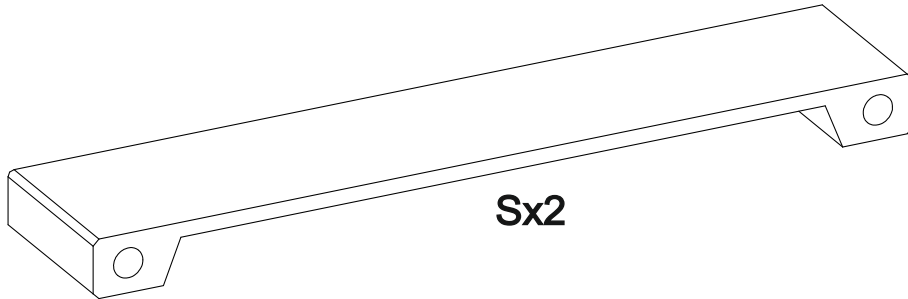
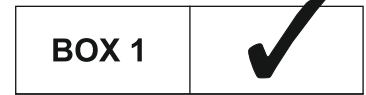
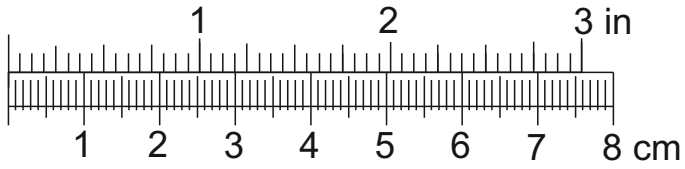

Nx6

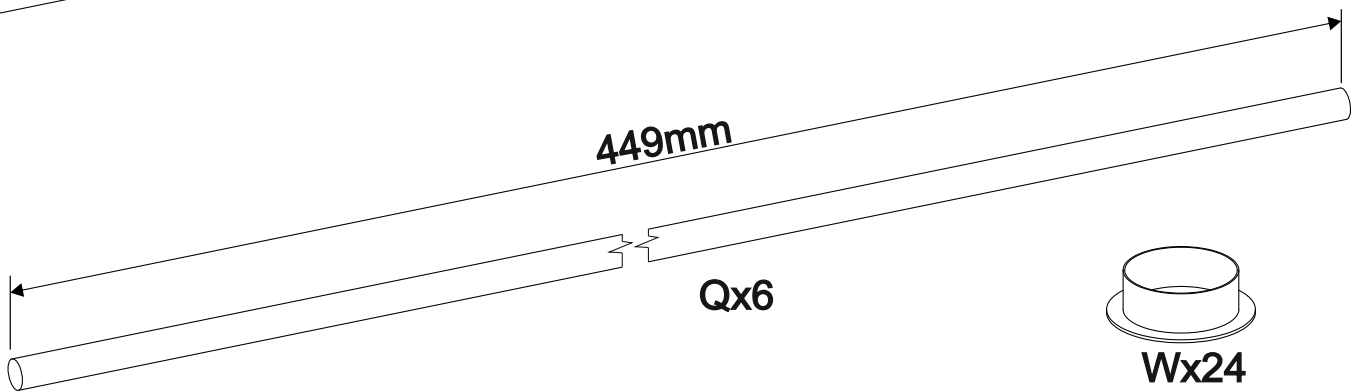
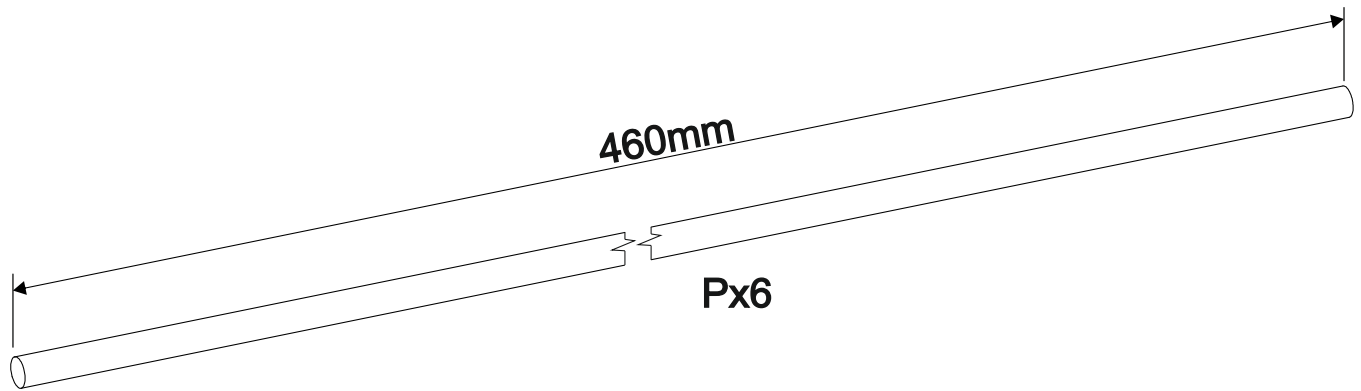
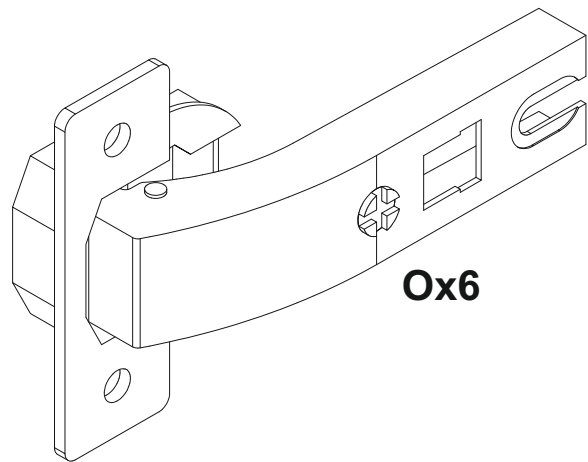

A

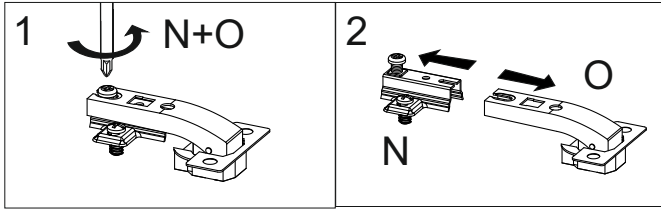

- Ø8 x 35

4 x
(A)
- 2 x
(F)
- 2 x
(G)
- 3 x
(N)
- 3 x
(T)
- 2,5 x 10

3 x
(U)

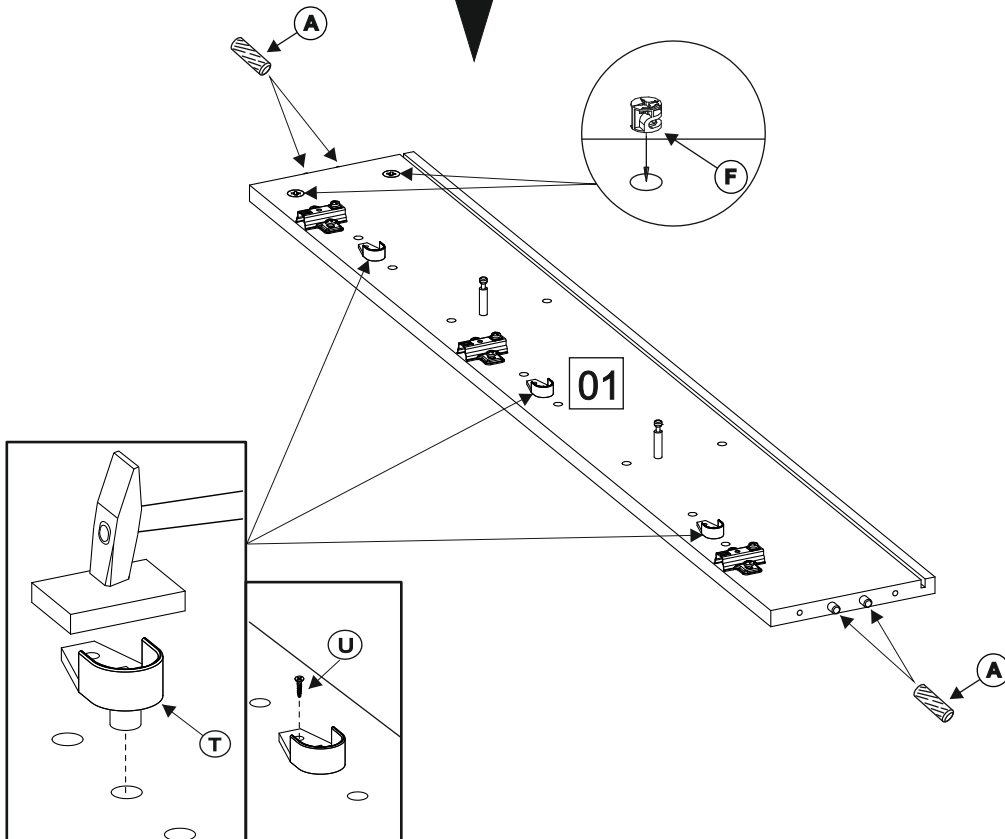
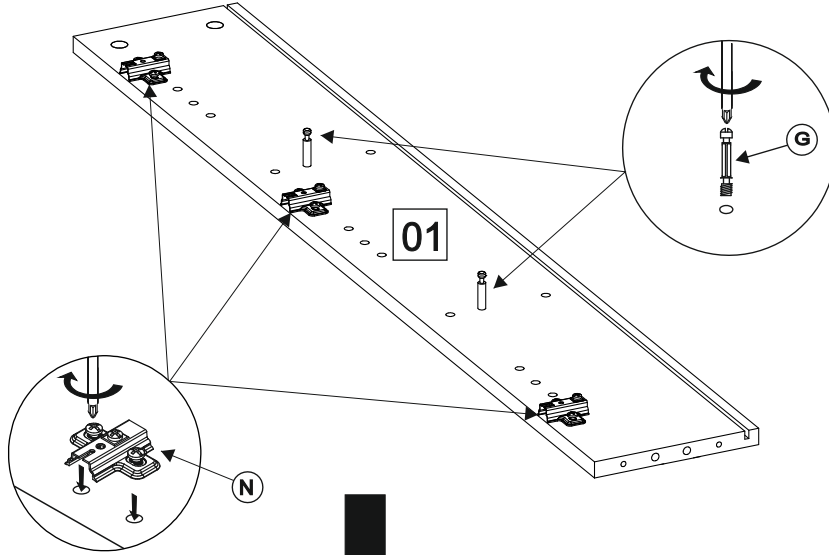

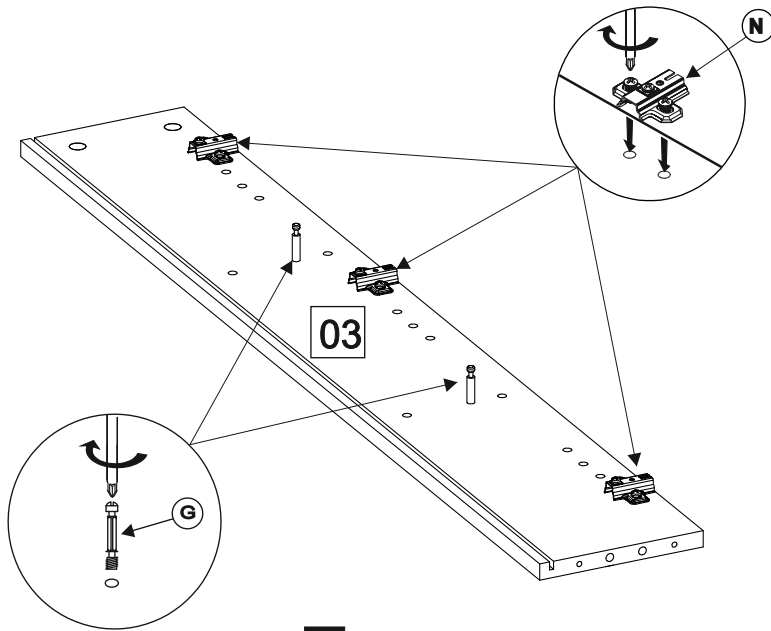

B





- Ø8 x 35**



4 x (A)
- 

2 x (F)
- 

2 x (G)
- 

3 x (N)
- 

3 x (T)
- 2,5 x 10**



3 x (U)

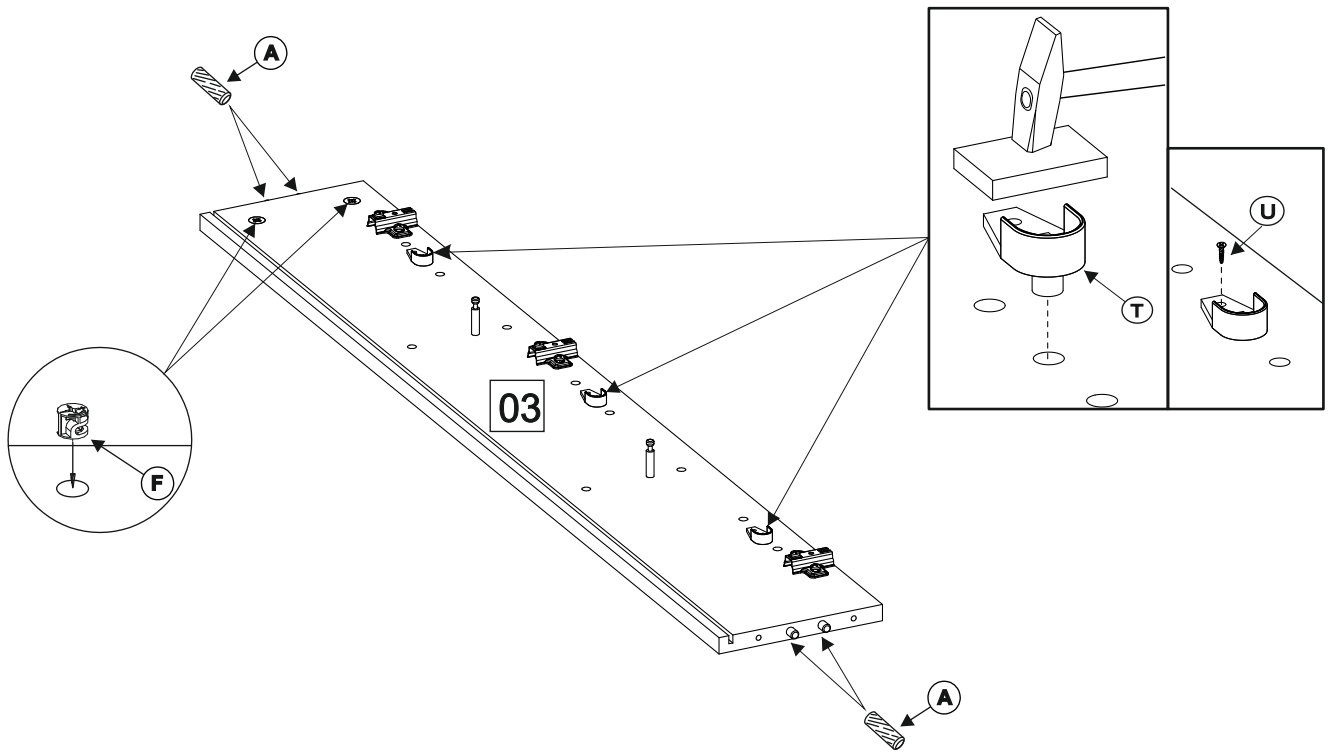

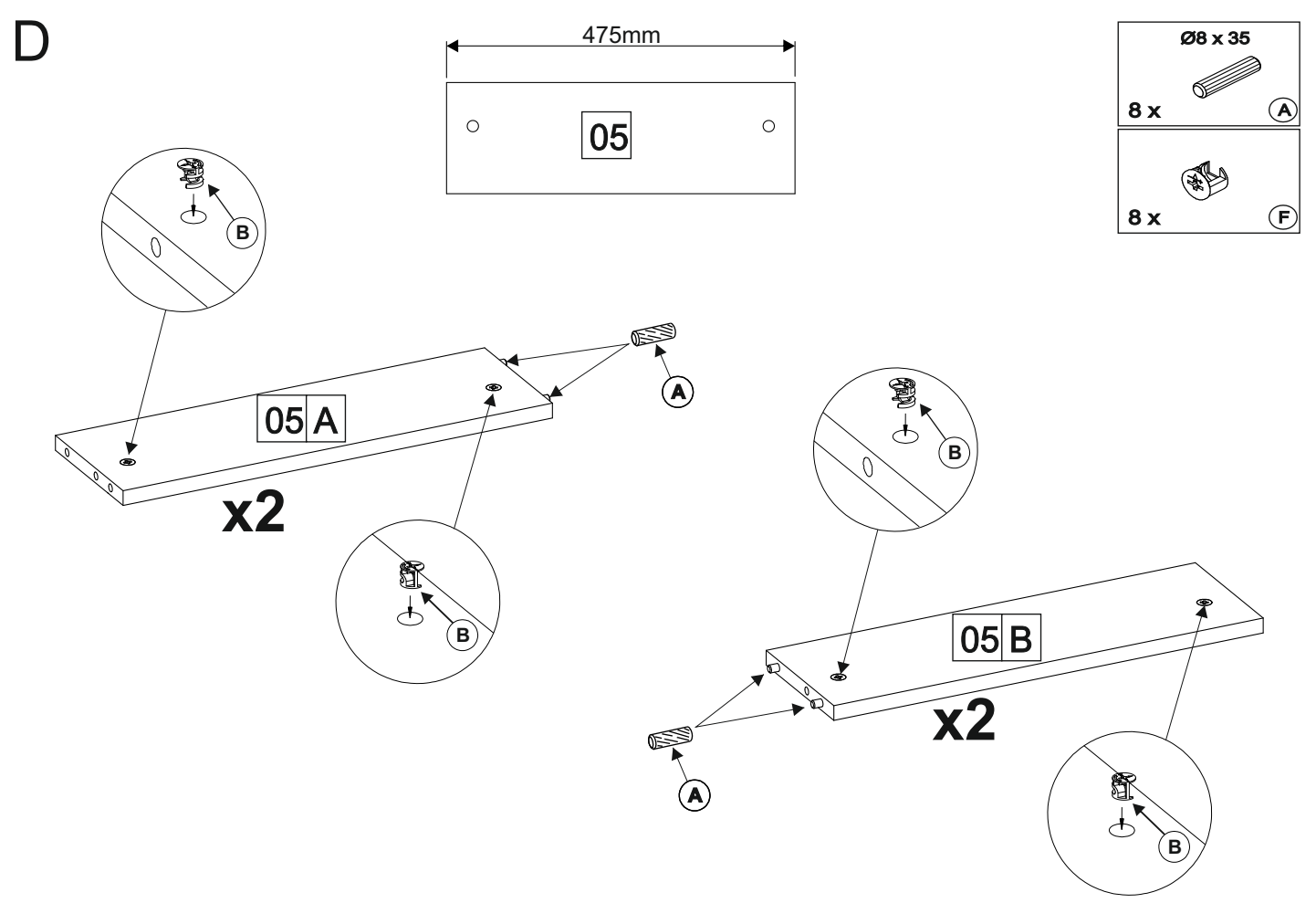
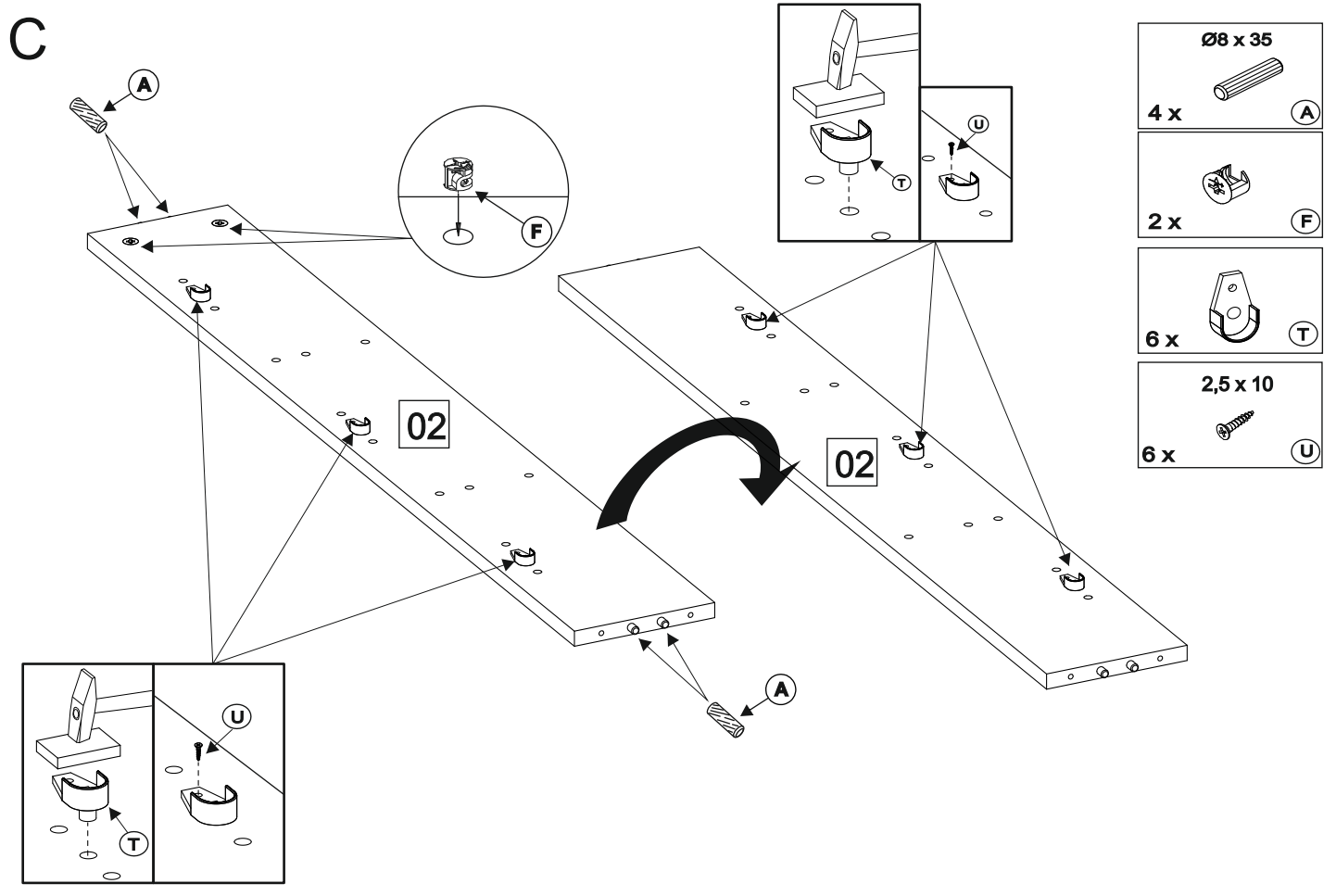

E

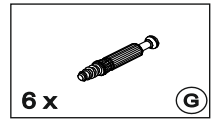
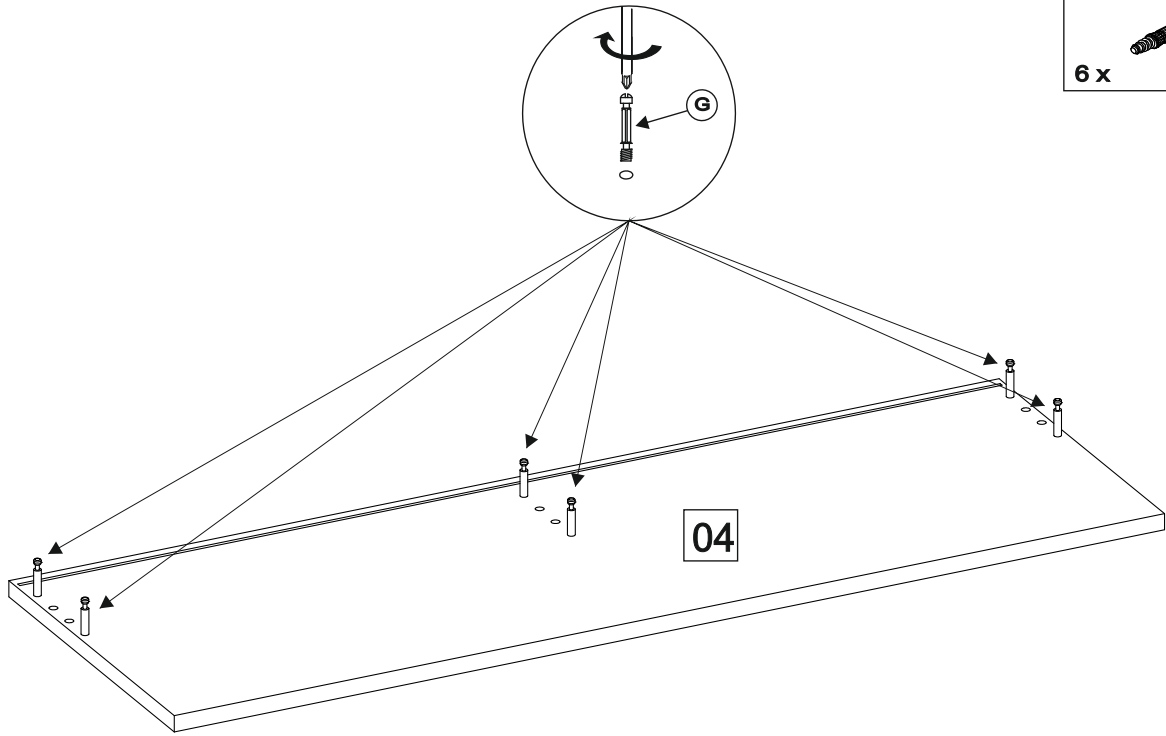

F

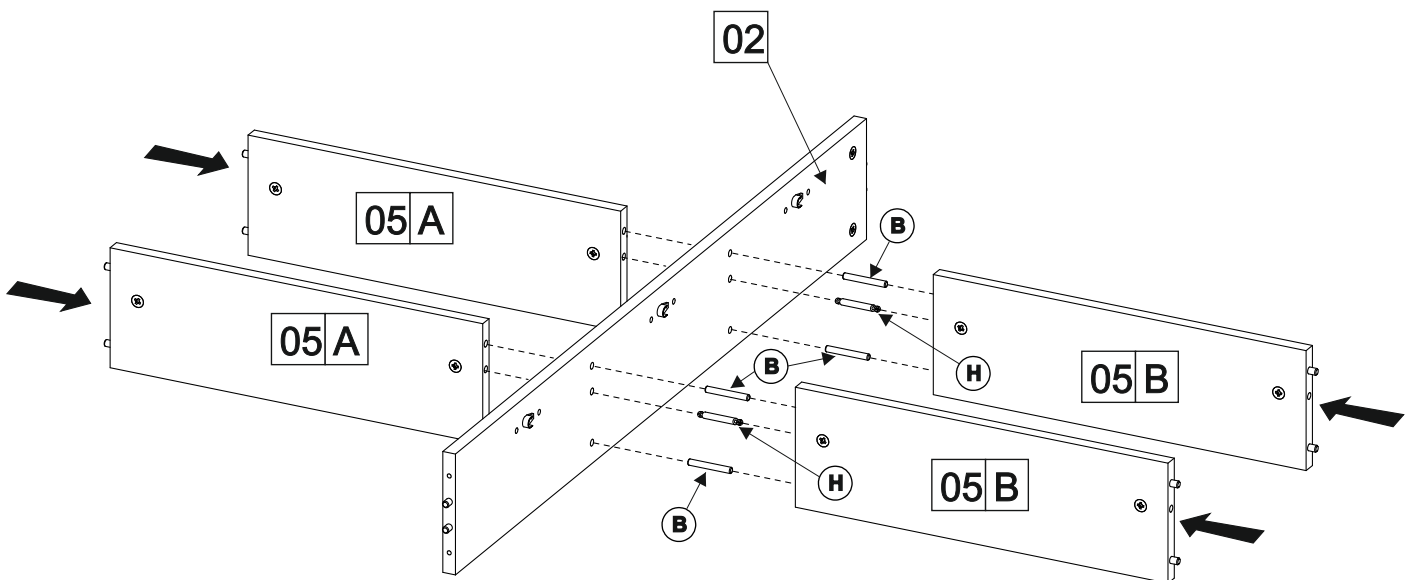
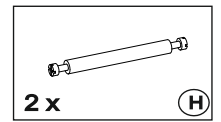
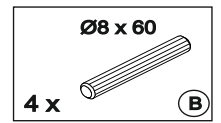
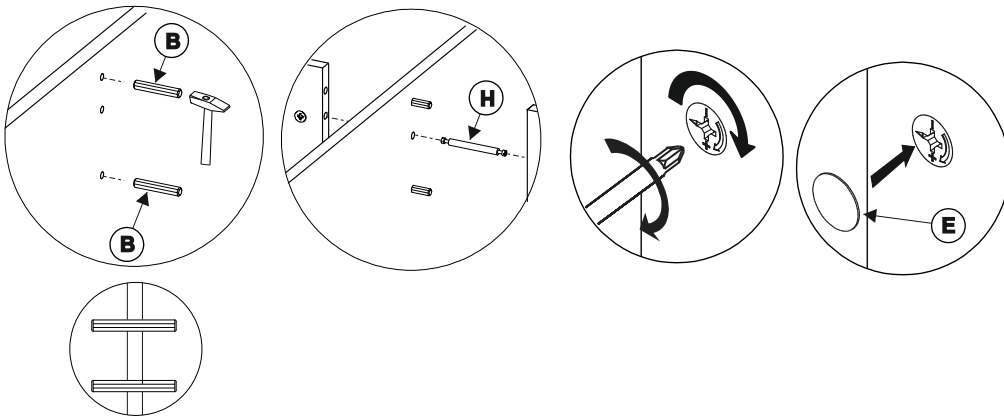

G

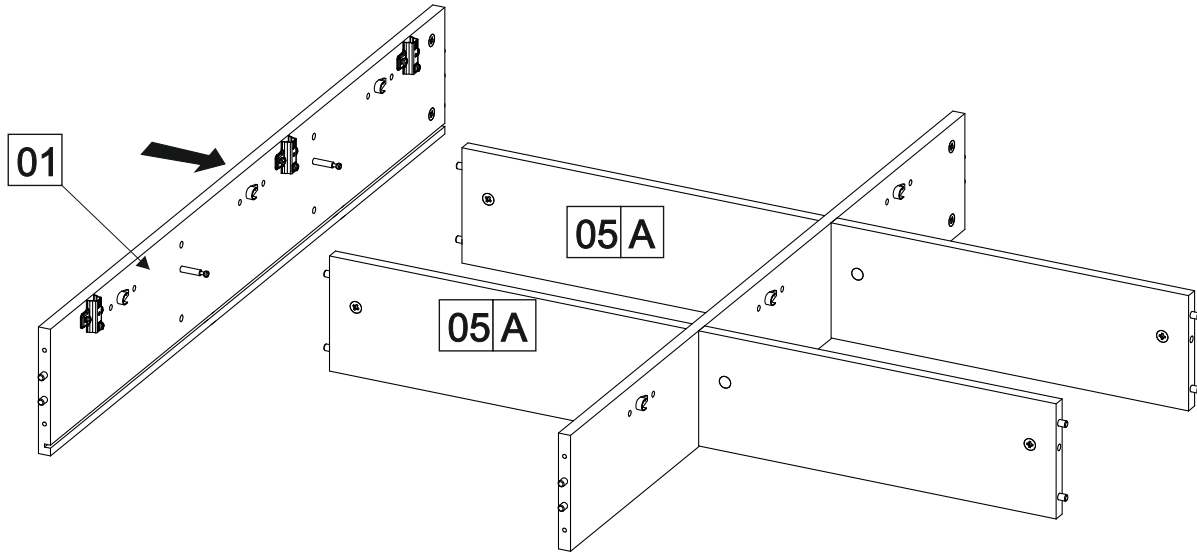
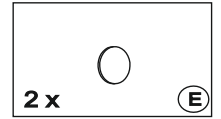
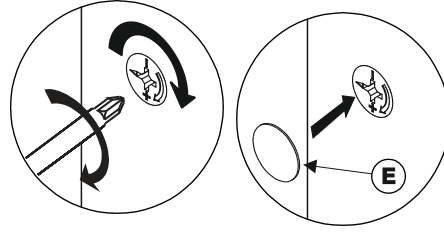

H

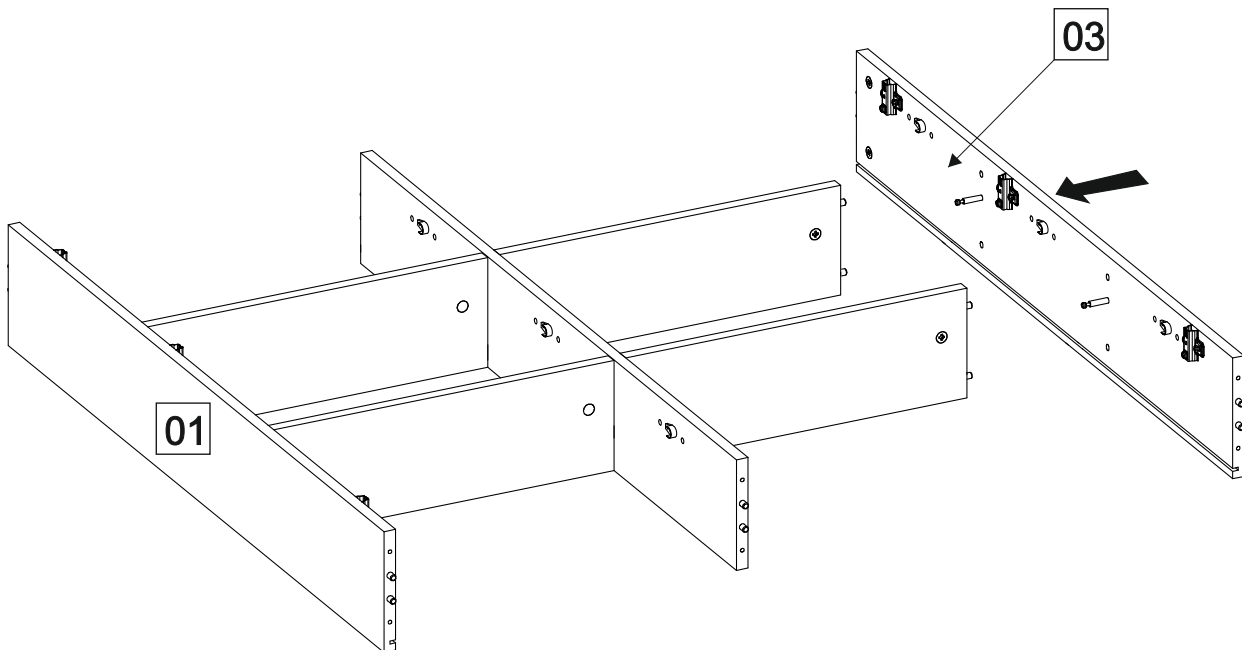
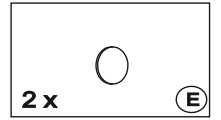
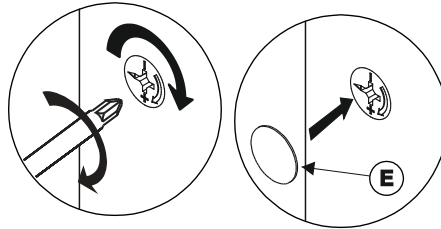

I

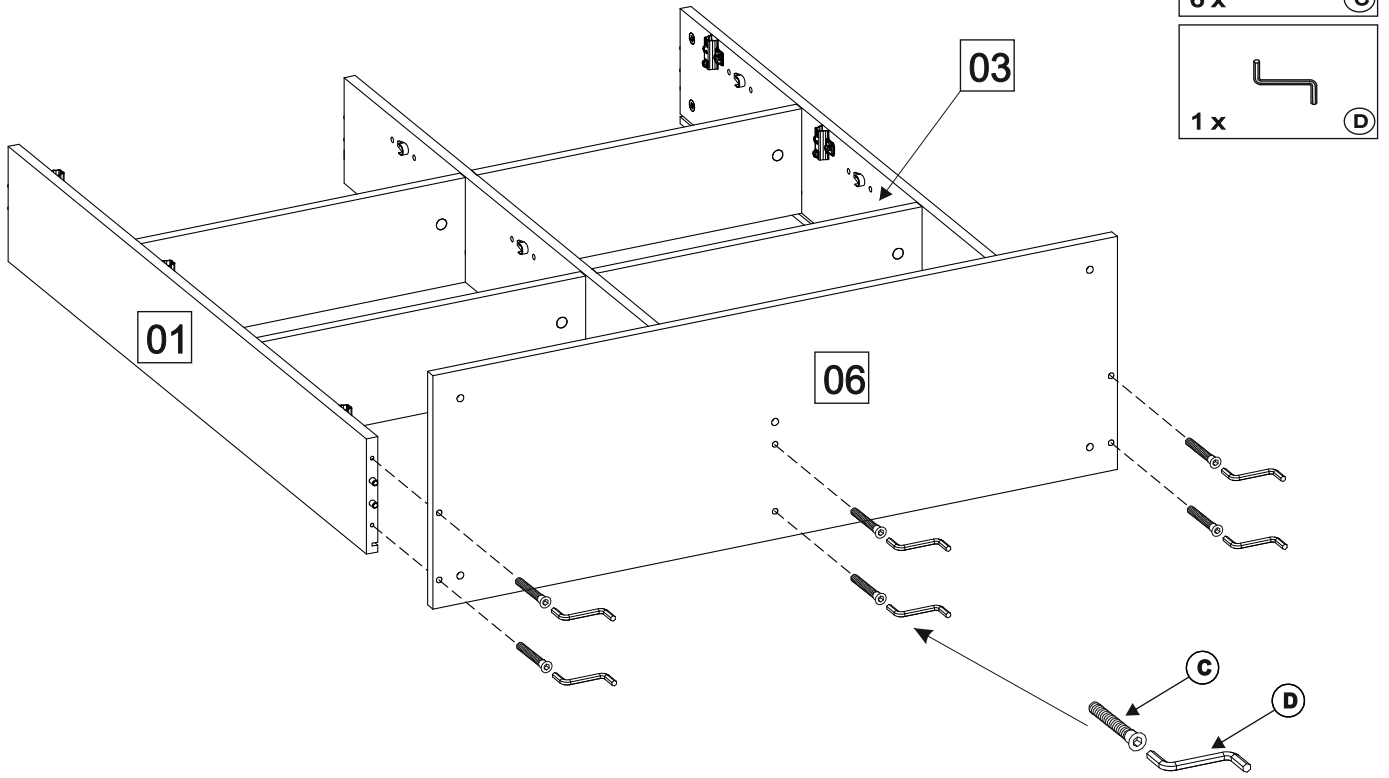

J

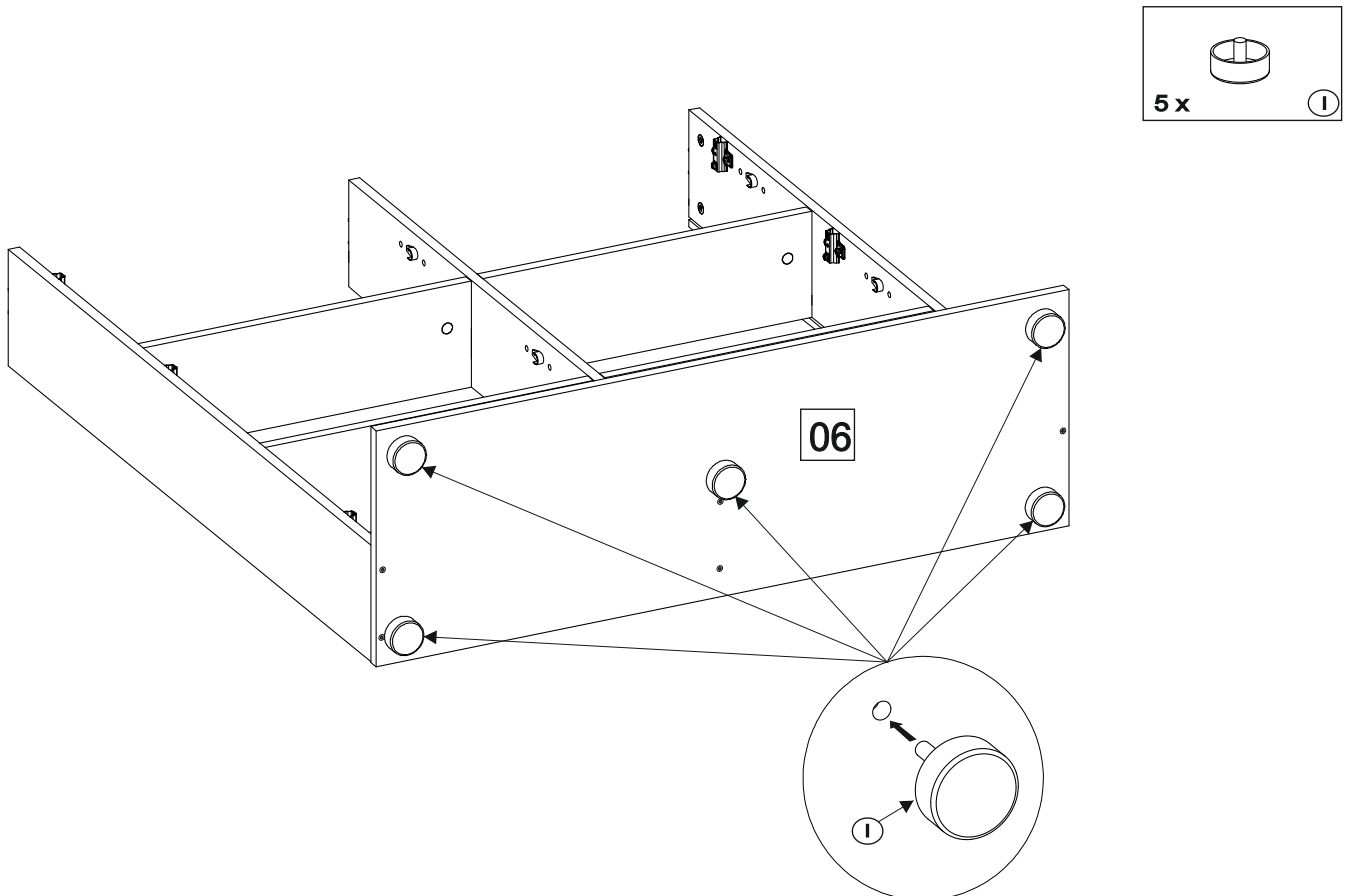

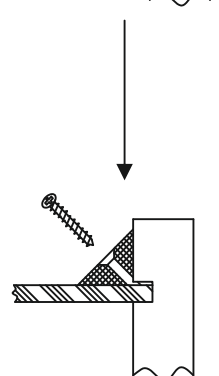
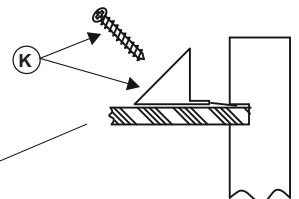
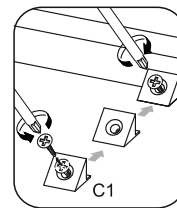
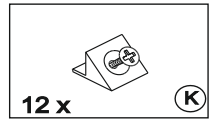
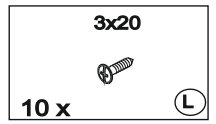
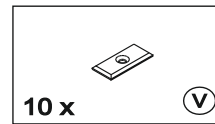
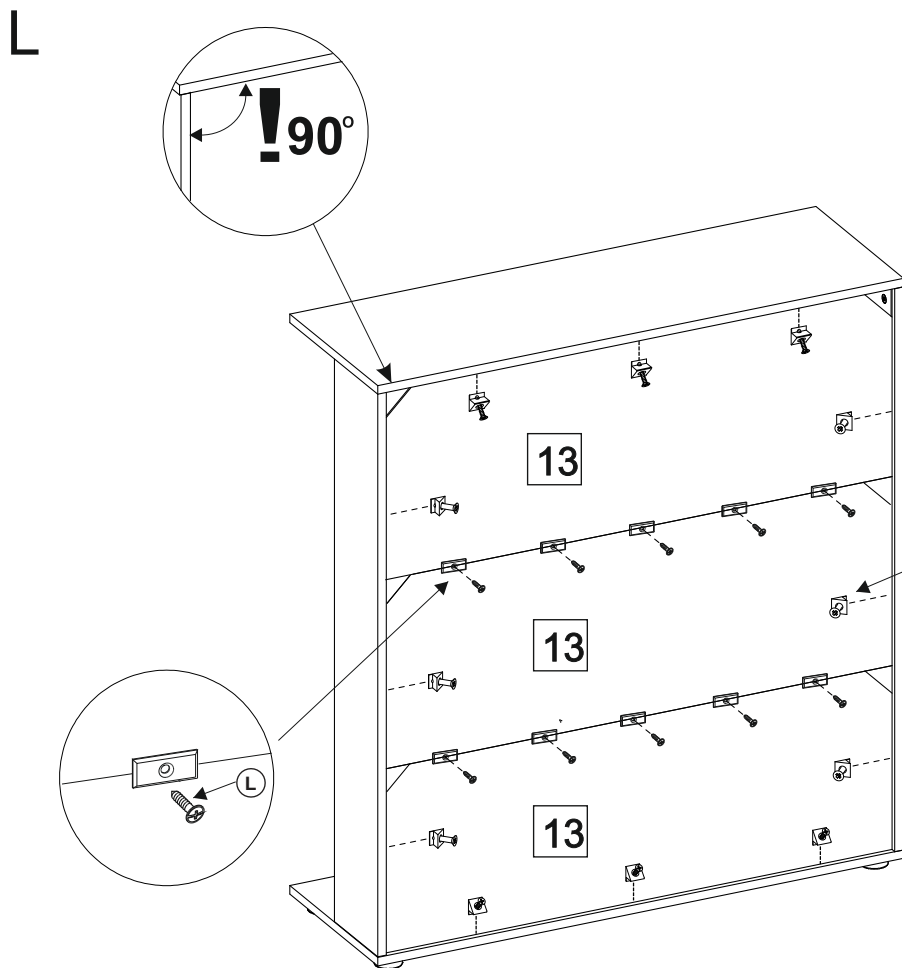
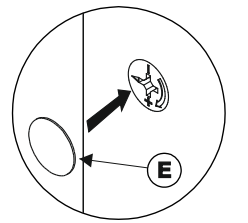
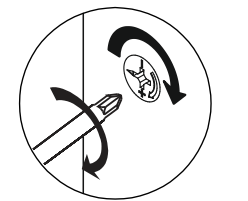
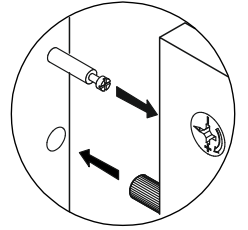
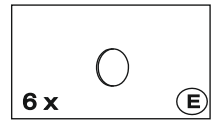
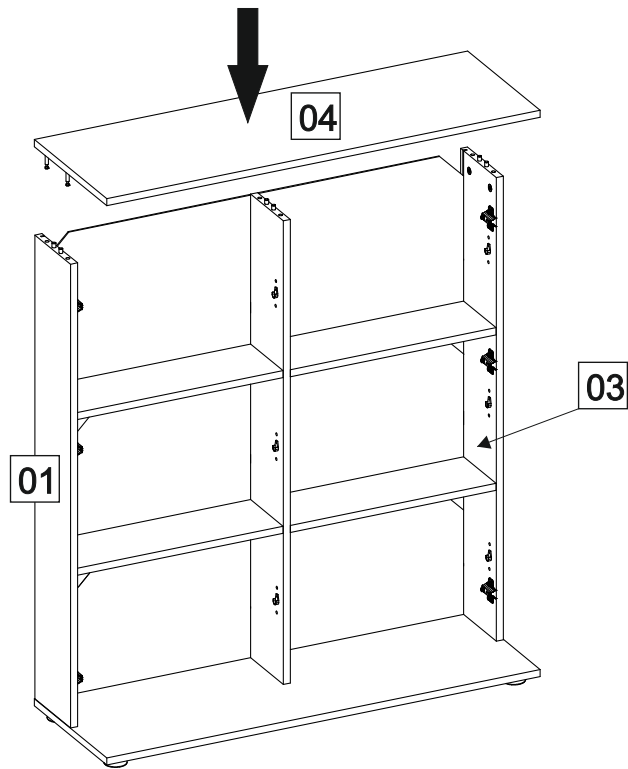
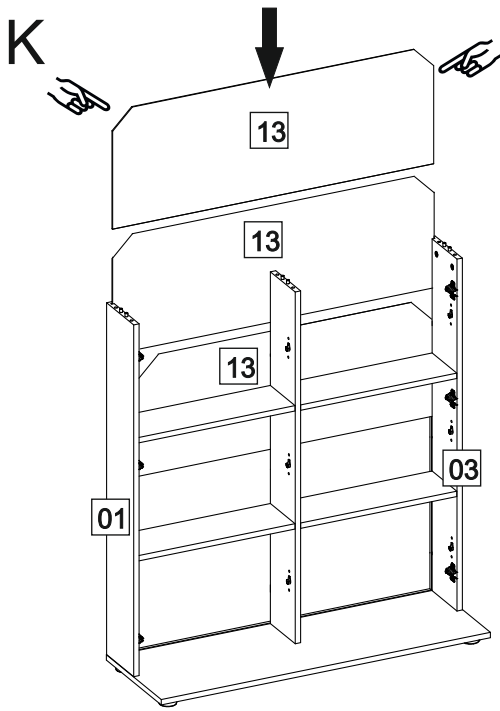

M

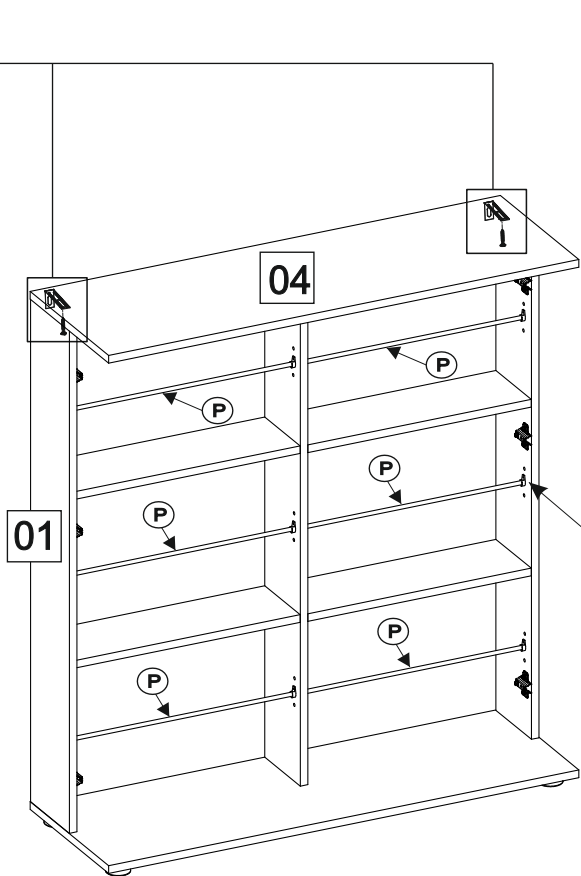
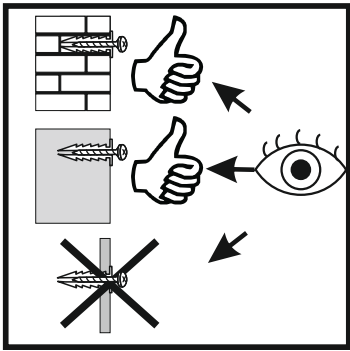
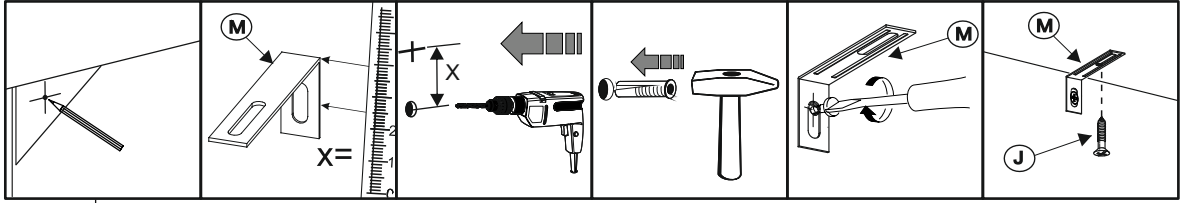

- 2x (M)
- 3,5 x 16
2x (J)
- 460mm
6 x (P)
- 12 x (W)

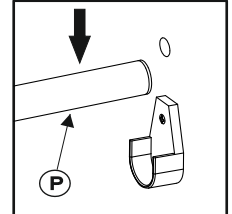
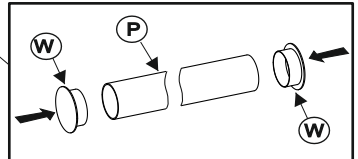

M

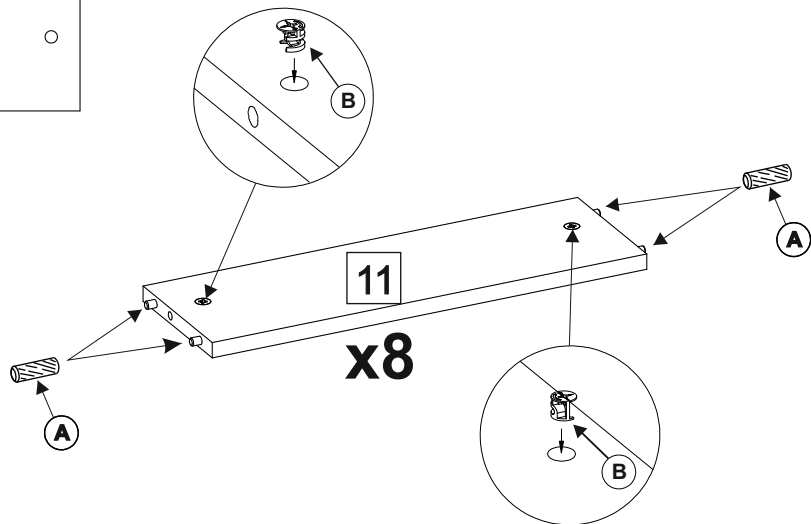
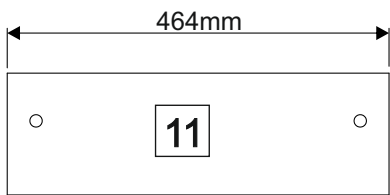

- Ø8 x 35
32 x (A)
- 16 x (B)

O

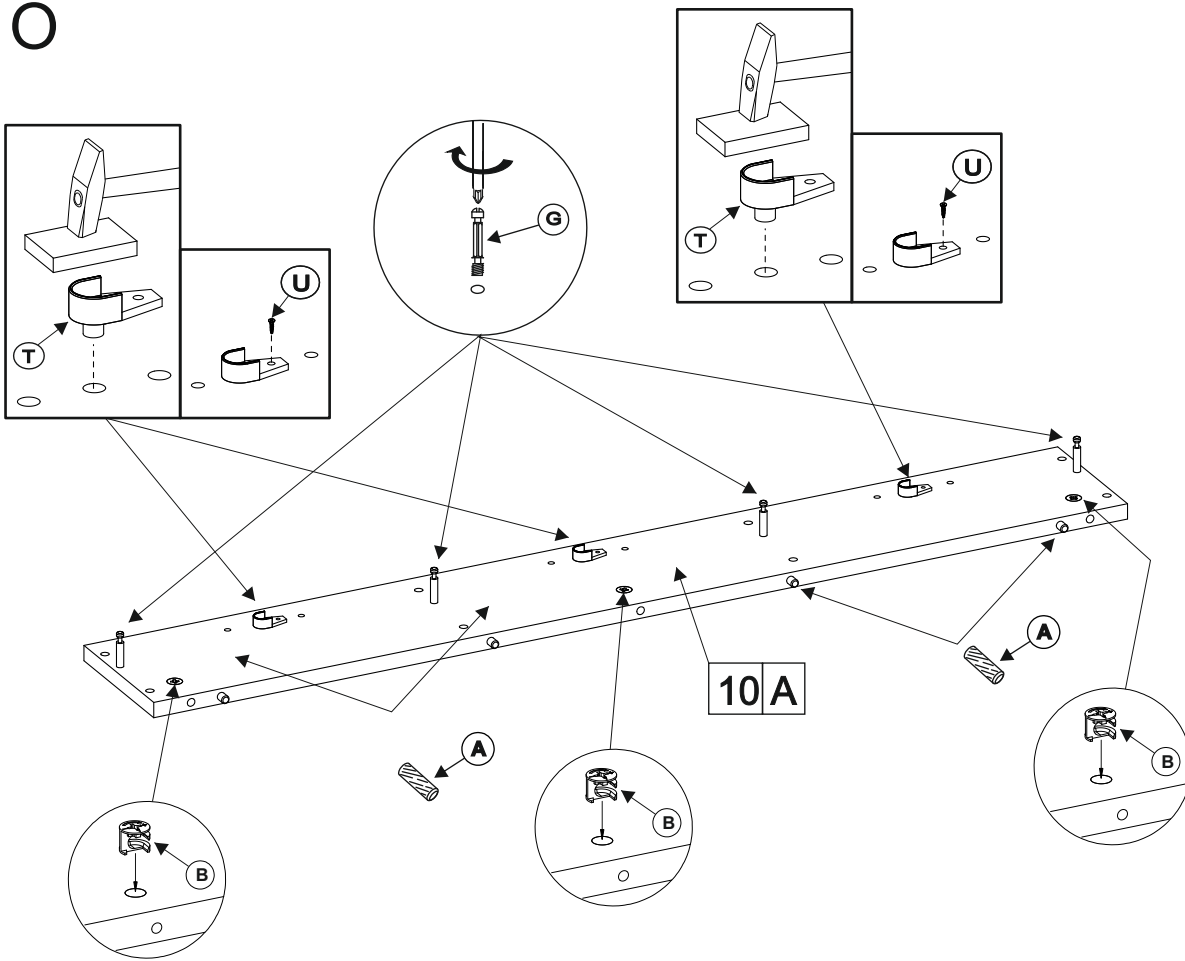

- $\text{Ø}8 \times 35$
4 x (A)
- $\text{Ø}8 \times 35$
3 x (F)
- $2,5 \times 10$
4 x (G)
- $2,5 \times 10$
3 x (U)
- (T)
- (B)

P

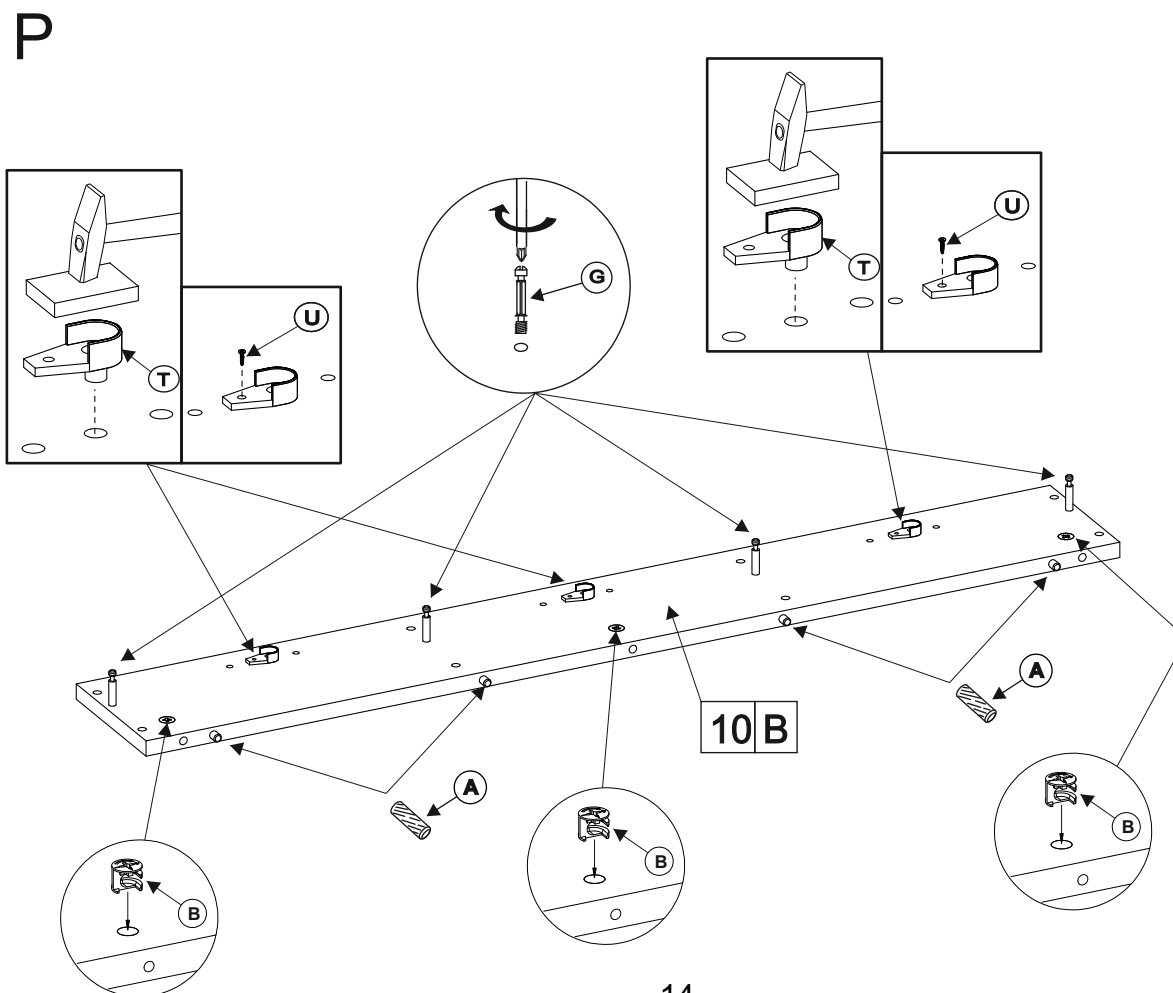



- $\text{Ø}8 \times 35$
4 x (A)
- $\text{Ø}8 \times 35$
3 x (F)
- $2,5 \times 10$
4 x (G)
- $2,5 \times 10$
3 x (U)
- (T)
- (B)

Q

- Ø8 x 35**



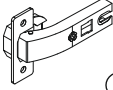

4 x (A)
- 

3 x (F)
- 

4 x (G)
- 

3x (C)
- 3,5 x 16**



6x (J)
- 

3 x (T)
- 2,5 x 10**



3 x (U)

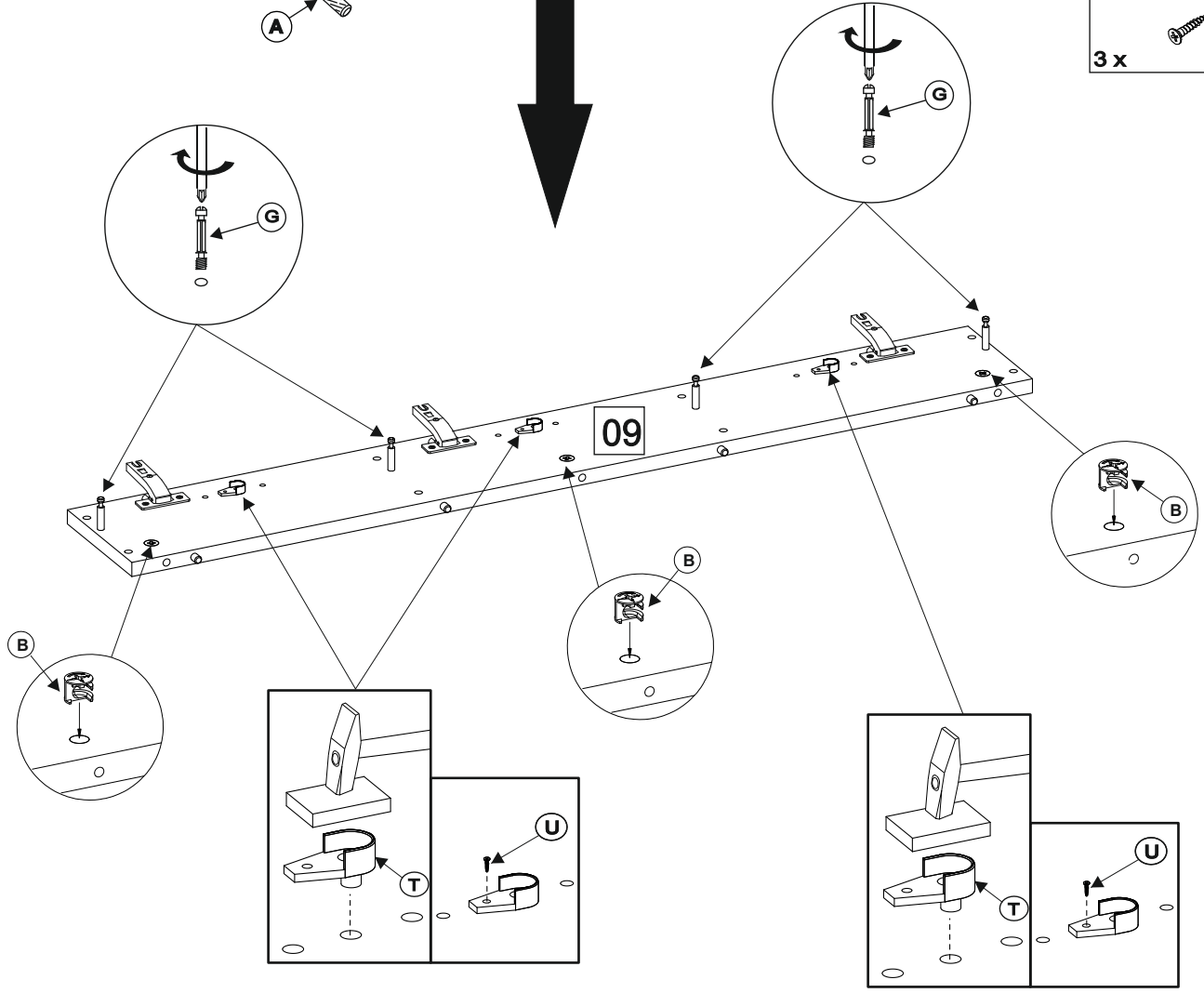
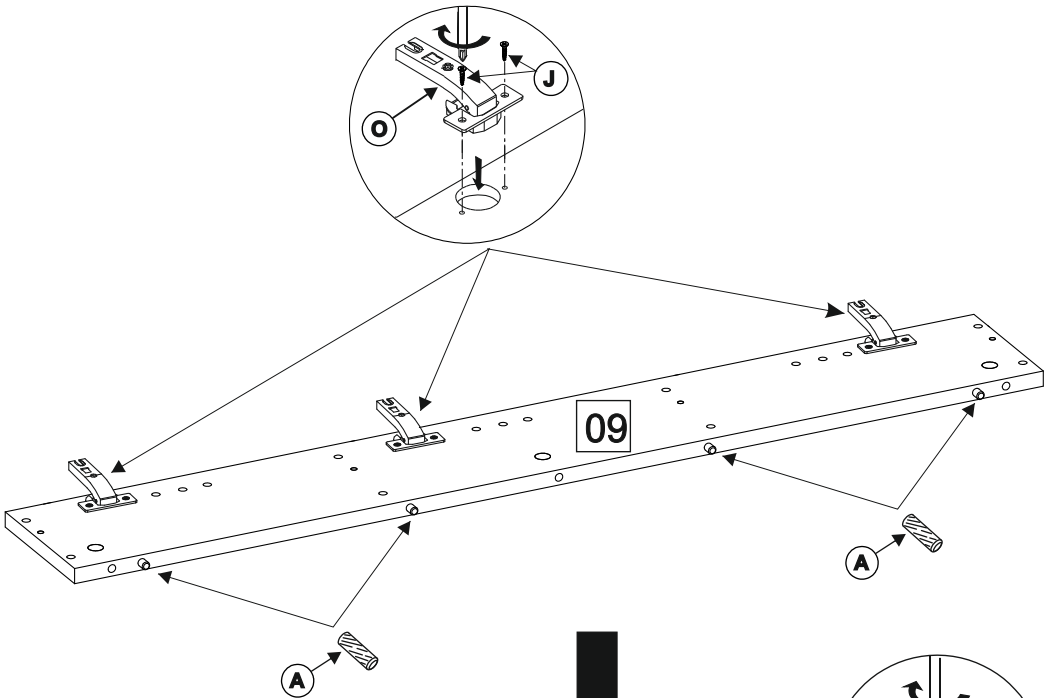

R

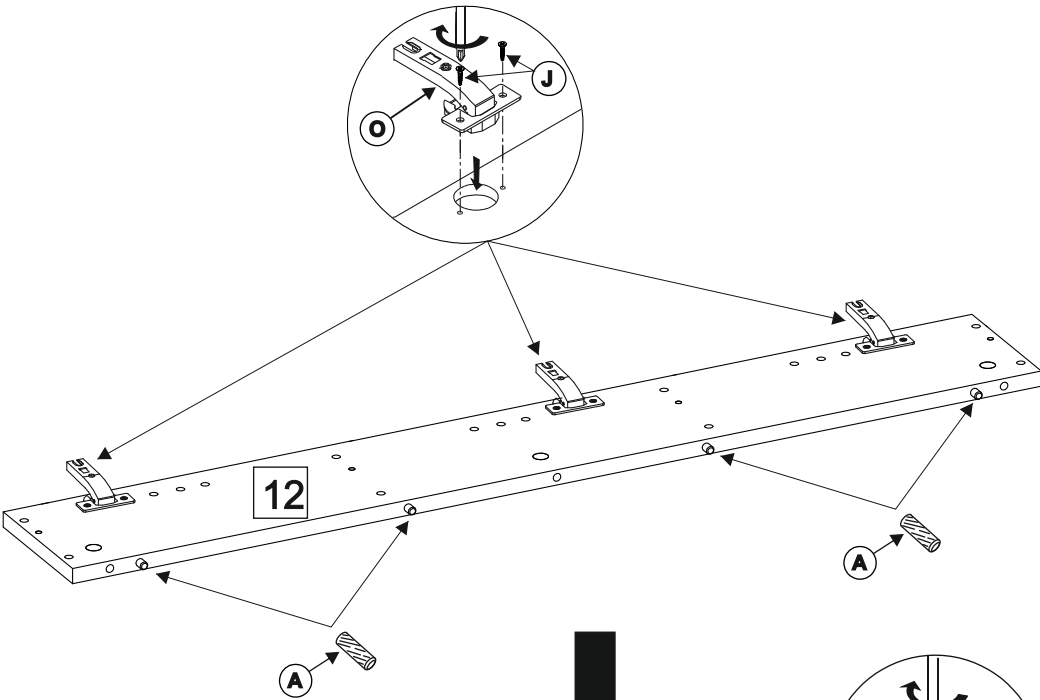

- Ø8 x 35
(A)

4 x
- (F)

3 x
- (G)

4 x
- (O)

3x
- 3,5 x 16
(J)

6x
- (T)

3 x
- 2,5 x 10
(U)

3 x

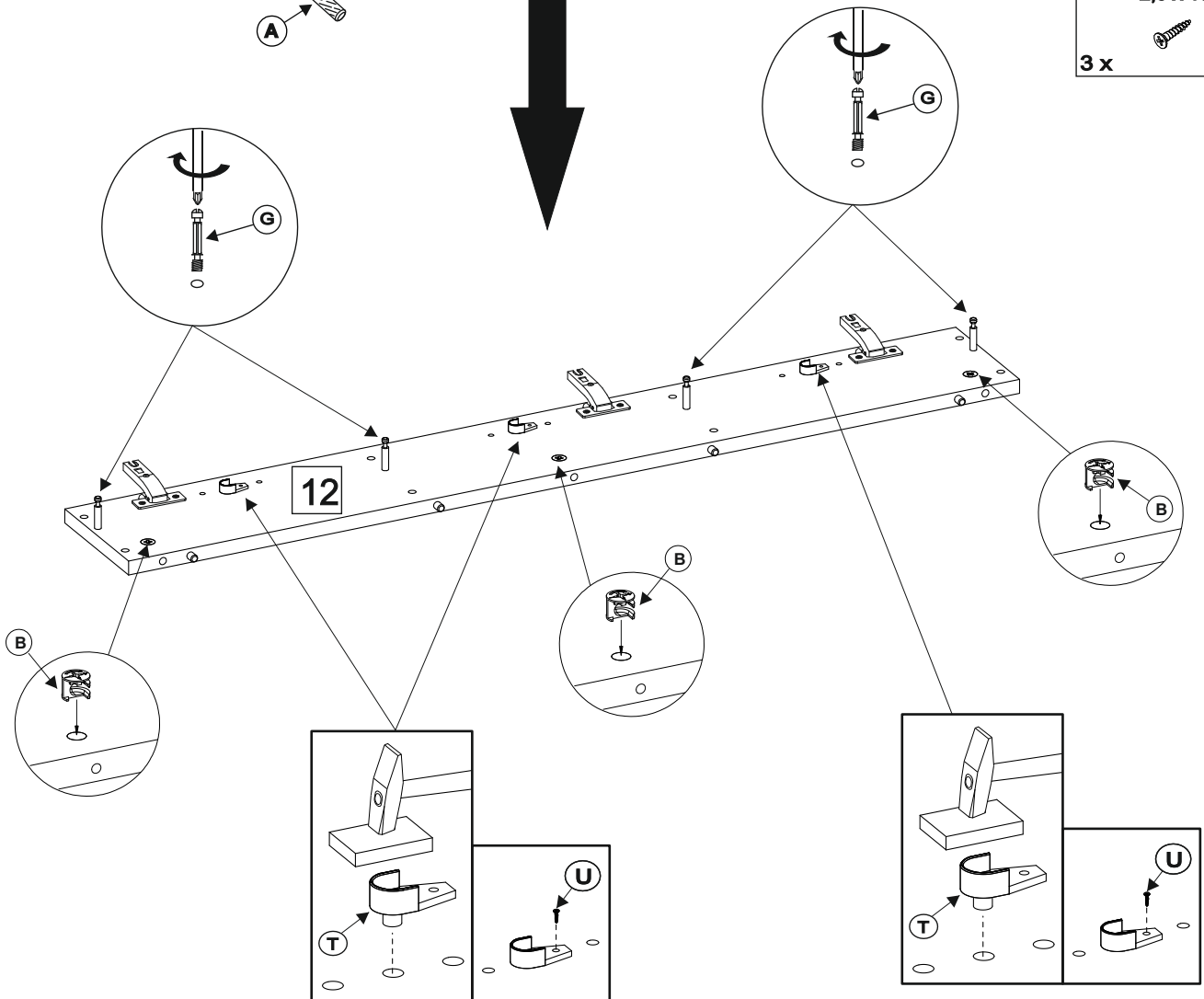

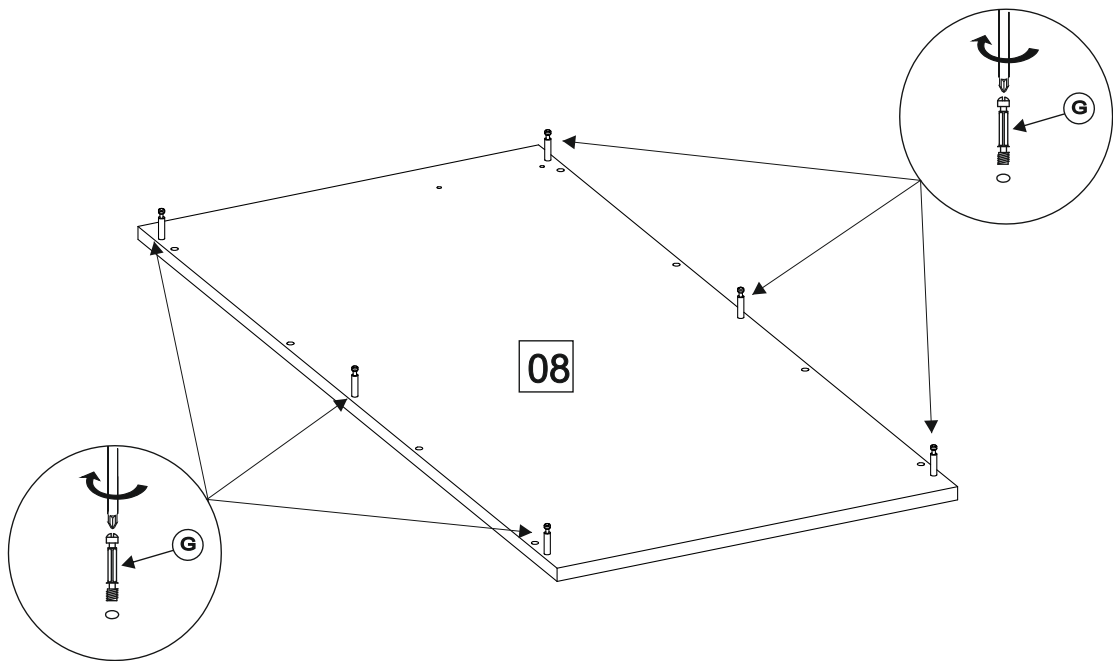
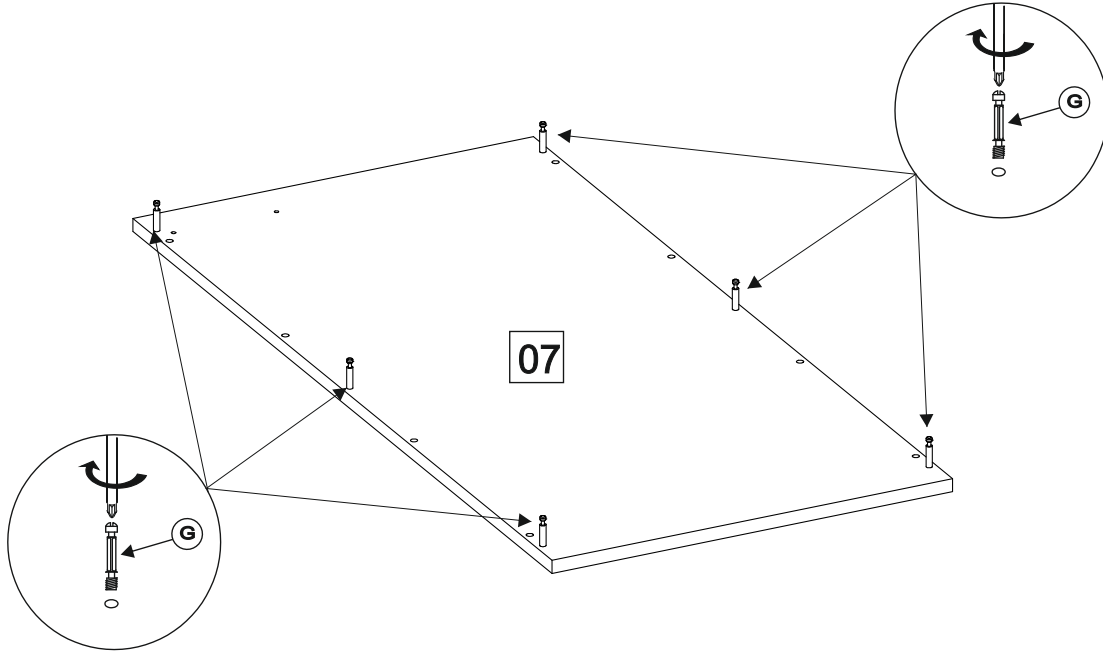
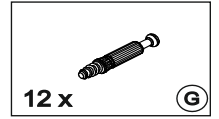

T

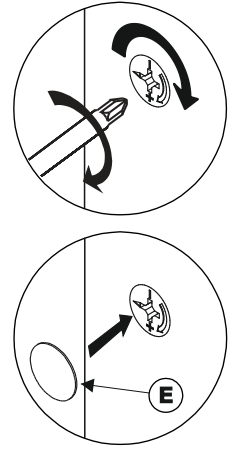
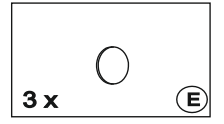
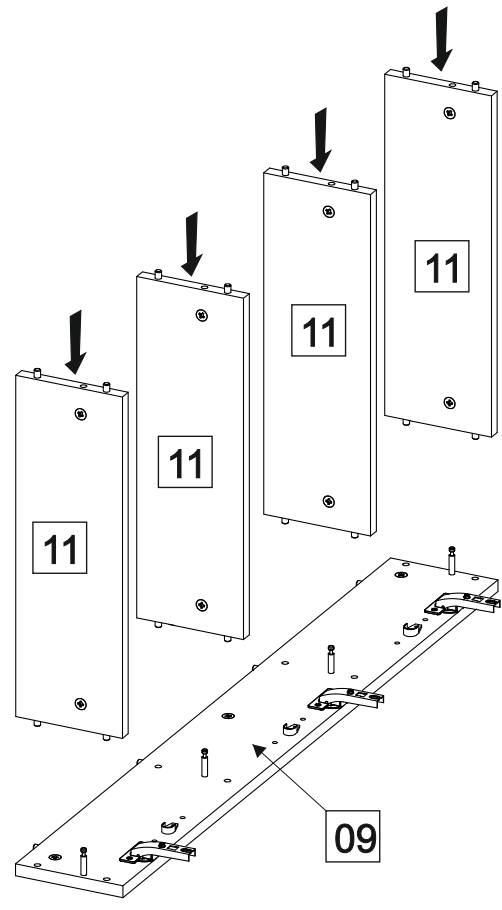

U

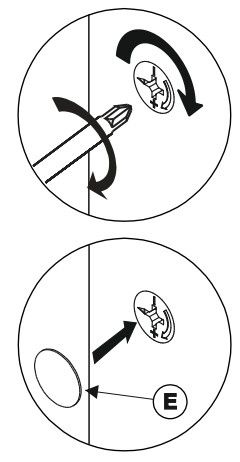
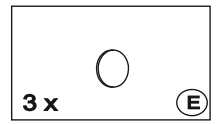
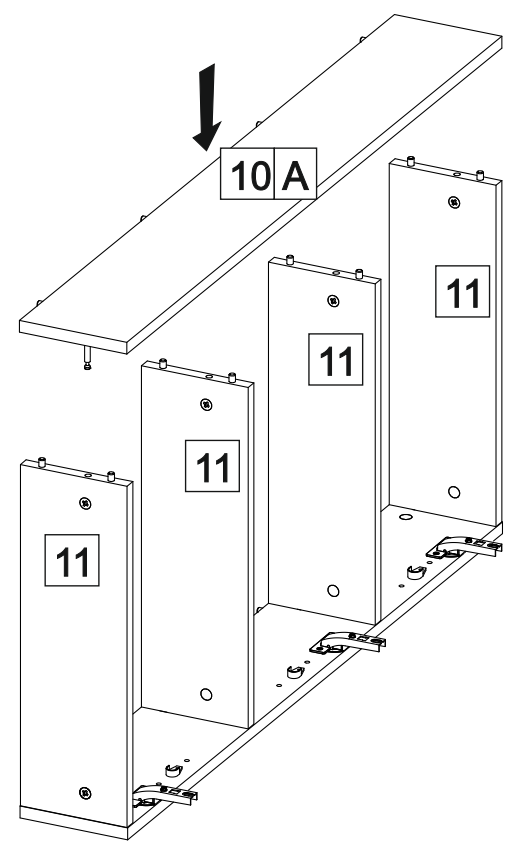

W

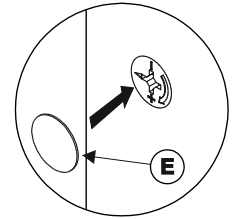
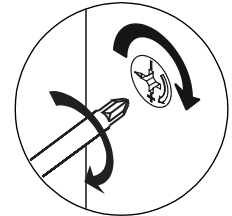
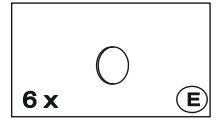
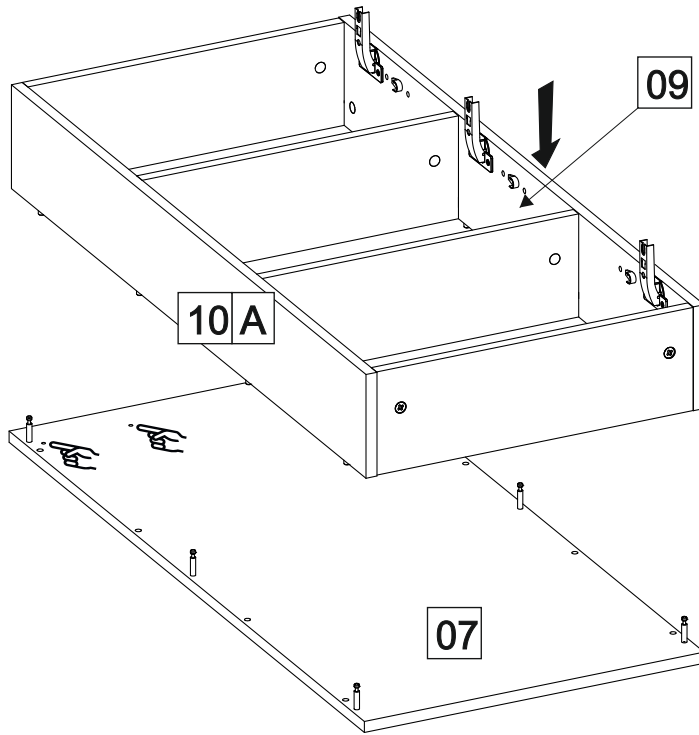

X

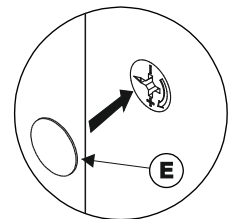
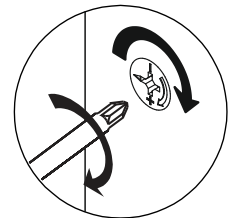
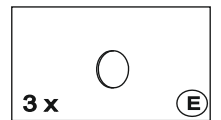
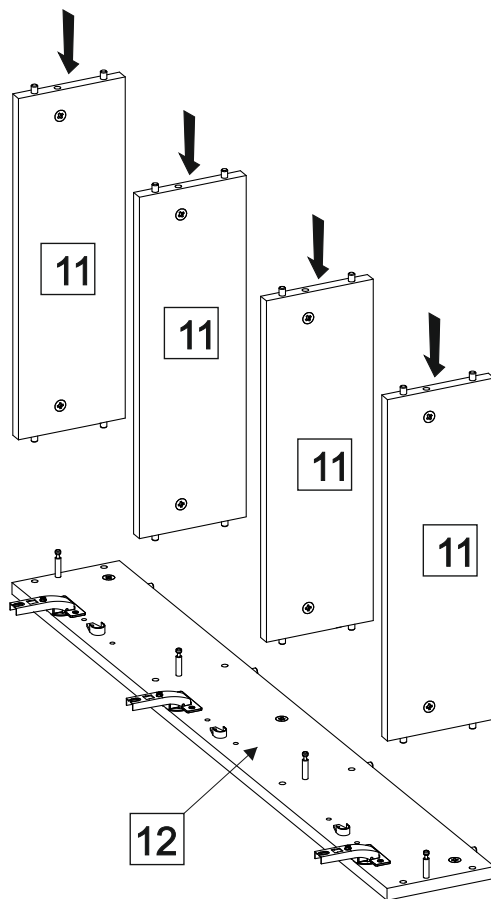

Y

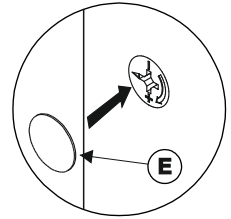
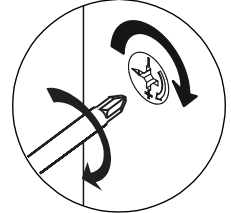
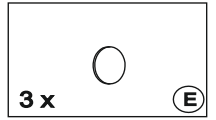
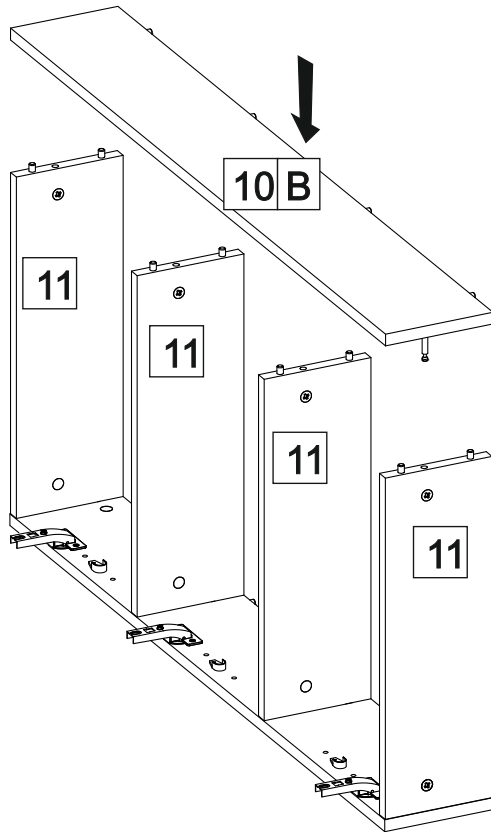

Z

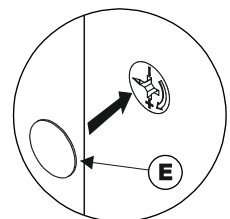
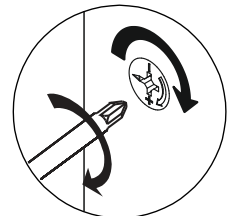
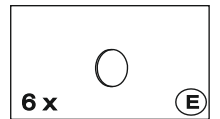
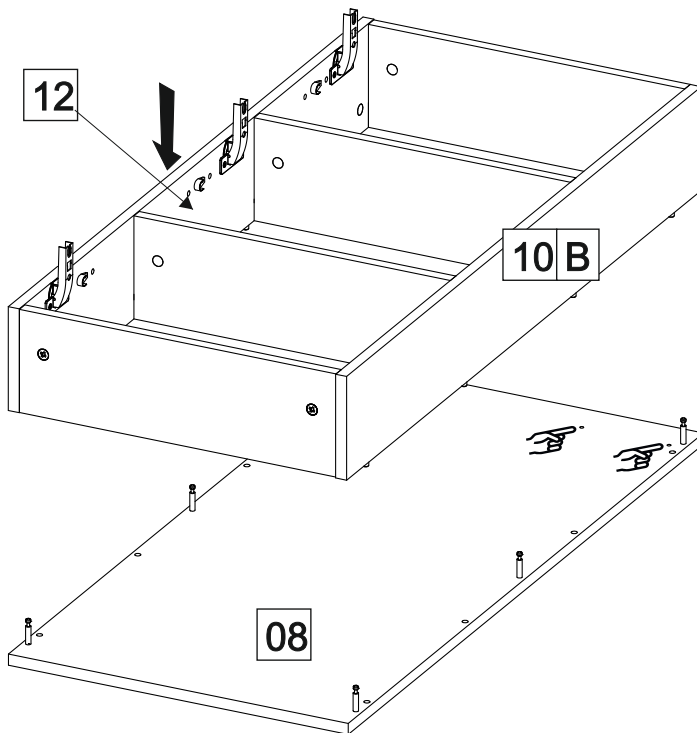

AA

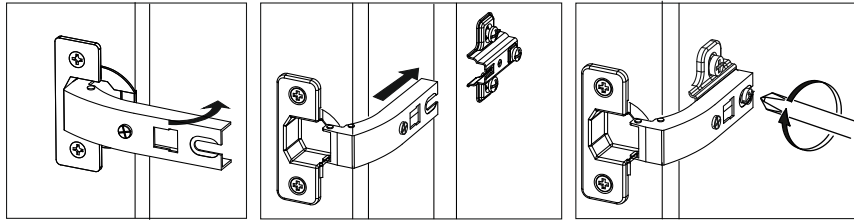

- 4 x 27
4 x (R)
- 2 x (S)
- 449mm
6 x (Q)
- 12 x (W)

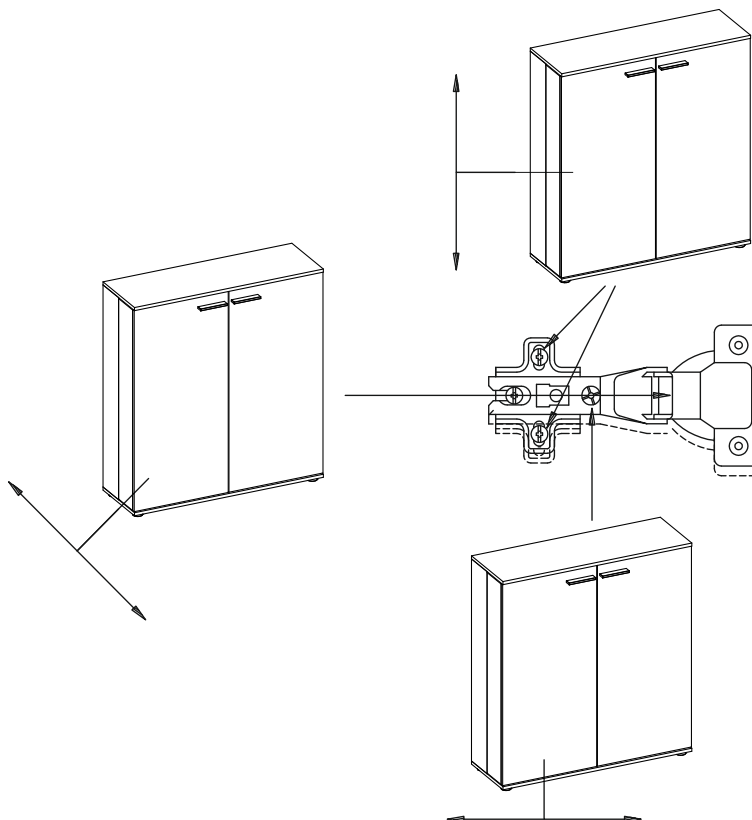
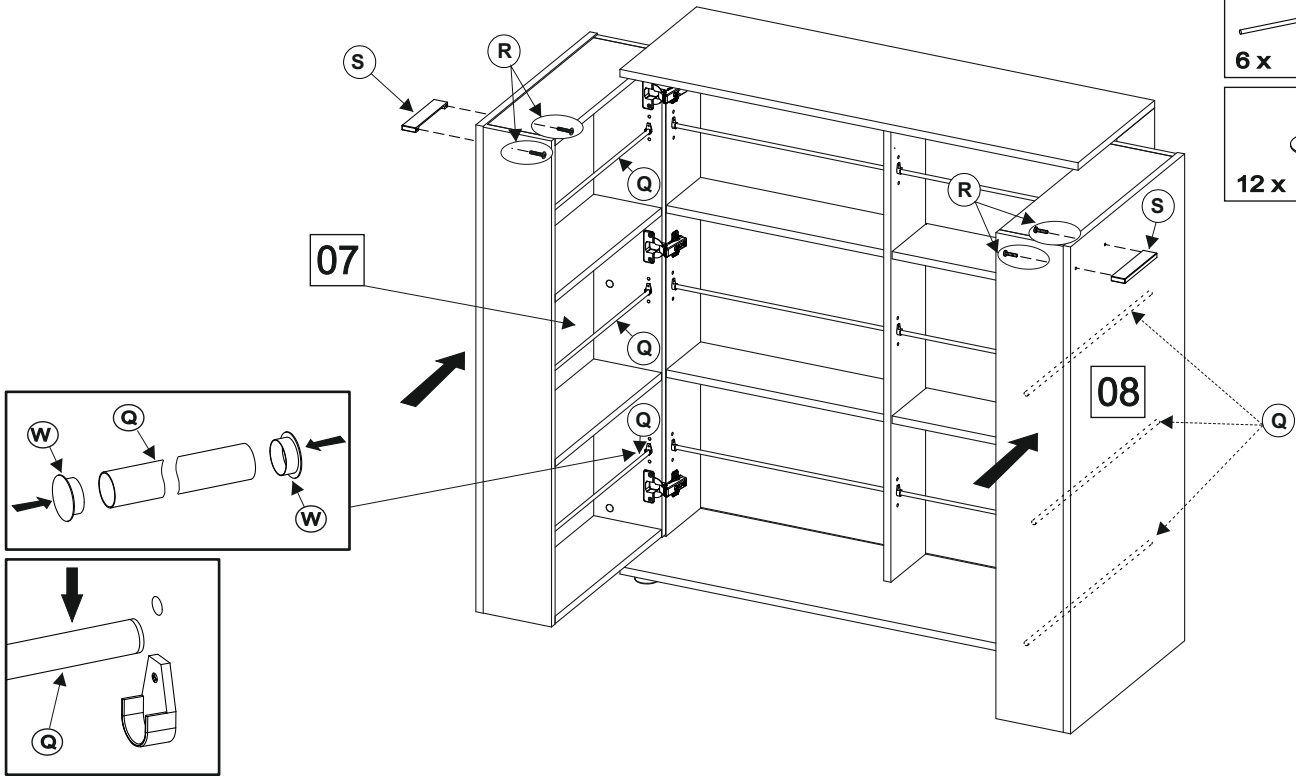



- (D) Das Möbel muss an der Wand befestigt werden!
- (GB) Please ensure to mount the furniture to the wall!
- (FR) Les meubles doivent être fixés au mur!
- (NL) Het meubel moet aan de wand worden vastgemaakt!
- (ES) El mueble se tiene que fijar a la pared!
- (PL) Mebel należy przymocować do ściany!



- (D) Informieren Sie sich vor der Wandmontage über das geeignete Montagematerial!
- (GB) Please get informed on suitable assembly materials before commencing the wall-mounting!
- (FR) Renseignez-vous sur le matériel de montage approprié avant le montage mural!
- (NL) Informeer u voor de wandmontage over het geschikte montagemateriaal!
- (ES) Infórmese antes del montaje en la pared del material apropiado de montaje!
- (PL) Przed montażem na ścianie upewnij się, jaki jest potrzebny właściwy materiał montażowy!



- (D) Beschaffen Sie sich das angemessene Material zur Wandbefestigung!
- (GB) Please obtain suitable wall-mounting materials!
- (FR) Procurez-vous le matériel approprié pour le montage mural!
- (NL) Verschaf u het adequate materieel voor de wandbevestiging!
- (ES) Procúrese el material adecuado para la fijación a la pared!
- (PL) Zakup odpowiedni materiał do przymocowania na ścianie!



- (D) Lassen Sie die Wandbefestigung von einer fachkundigen Person vornehmen!
- (GB) Ensure all wall-mounting is carried out by competent personnel!
- (FR) Faites effectuer le montage mural par une personne compétente!
- (NL) Laat de wandbevestiging door een professional uitvoeren!
- (ES) Deje que la fijación a la pared la haga un profesional!
- (PL) Zleć przymocowanie do ściany odpowiednio doświadczonemu osobie!

- (RU) Мебель должна крепиться к стене!
- (IT) Il mobile deve essere fissato alla parete!
- (HU) A bútor a falon rögzítendő!
- (P) O móvel tem que ser fixado na parede!
- (CZ) Nábytek musí být připevněn ke stěně!
- (SK) zverte kvalifikovanej ozone!

- (RU) Перед тем, как крепить мебель к стене, получите информацию о подходящем крепежном материале!
- (IT) Prima del fissaggio alla parete, informarsi sul materiale di montaggio adatto!
- (HU) A falra szerelés előtt tájékozódjon, hogy ehhez milyen szerelőanyagok szükségesek!
- (P) Antes da montagem na parede, informe-se sobre o material de montagem adequado!
- (CZ) Informujte se o vhodném montážním materiálu před montáží na stěnu!
- (SK) Pred montážou na stenu sa informujte o vhodnom montážnom materiáli!

- (RU) Приобретите соответствующий материал для крепления к стене!
- (IT) Procurarsi il materiale opportuno per il fissaggio alla parete!
- (HU) Szerezze be a falra szereléshez szükséges, megfelelő anyagokat!
- (P) Obtenha o material adequado para a montagem na parede!
- (CZ) Opatřte si vhodný materiál pro montáž na stěnu!
- (SK) Zabezpečte si vhodný materiál na montáž na stenu!

- (RU) Поручите выполнение работ по креплению к стене специалисту!
- (IT) Far effettuare il fissaggio alla parete ad un esperto!
- (HU) A bútor falra rögzítését végeztesse ehhez értő személlyel!
- (P) A montagem na parede deve ser executada por uma pessoa competente!
- (CZ) Montáž na stěnu nechte provést odborně způsobilou osobou!
- (SK) Montáž na stenu zverte kvalifikovanej osobe!

