

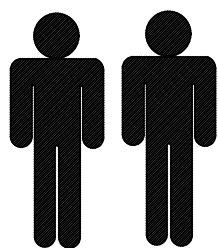

- PL -Montaż powinien być przeprowadzony zgodnie z instrukcją montażu producenta, w przeciwnym razie może pojawić się niebezpieczeństwo użytkowania.
- DE- Die Installation sollte gemäß den Installationsanweisungen des Herstellers erfolgen, da sonst die Gefahr einer Verwendung besteht.
- EN- Installation should be carried out in accordance with the manufacturer's installation instructions, otherwise there may be danger of use.
- CZ- Instalace by měla být provedena v souladu s instalačními pokyny výrobce, jinak může dojít k poškození.
- SK- Inštalácia by sa mala vykonávať v súlade s inštaláčnymi pokynmi výrobcu, inak môže dôjsť k poškodeniu.
- RU- Установка должна выполняться в соответствии с инструкциями производителя по установке, в противном случае может возникнуть опасность использования.
- SRB- Instalaciju treba izvesti u skladu sa uputstvima za ugradnju proizvođača, jer u suprotnom može doći do opasnosti od uporabe.
- HR- Instalaciju treba izvoditi u skladu s uputama za ugradnju proizvođača, jer u suprotnom može doći do opasnosti od uporabe.
- HU- A telepítést a gyártó telepítési útmutatója szerint kell elvégezni, különben a használat veszélye áll fenn.

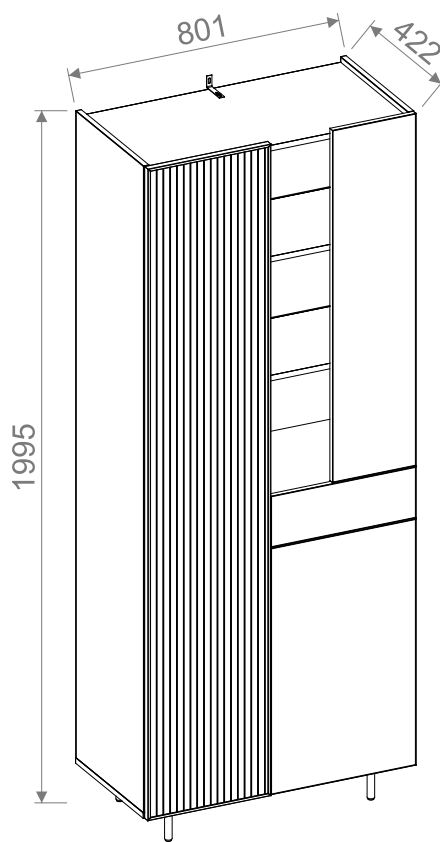

120 min

Potrzebne narzędzia/ Benötigtes Werkzeug/ Required tools/ Potřebné nástroje/  
Potrebné nástroje/ Необходимые инструменты/ Potreban alat/ Szereléshez szükséges szerszámok

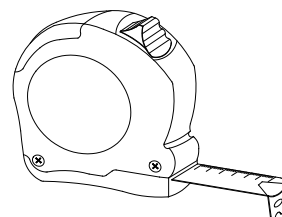
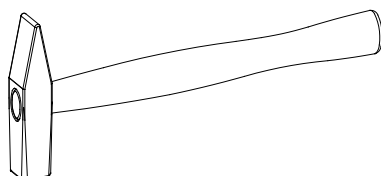
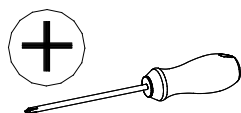



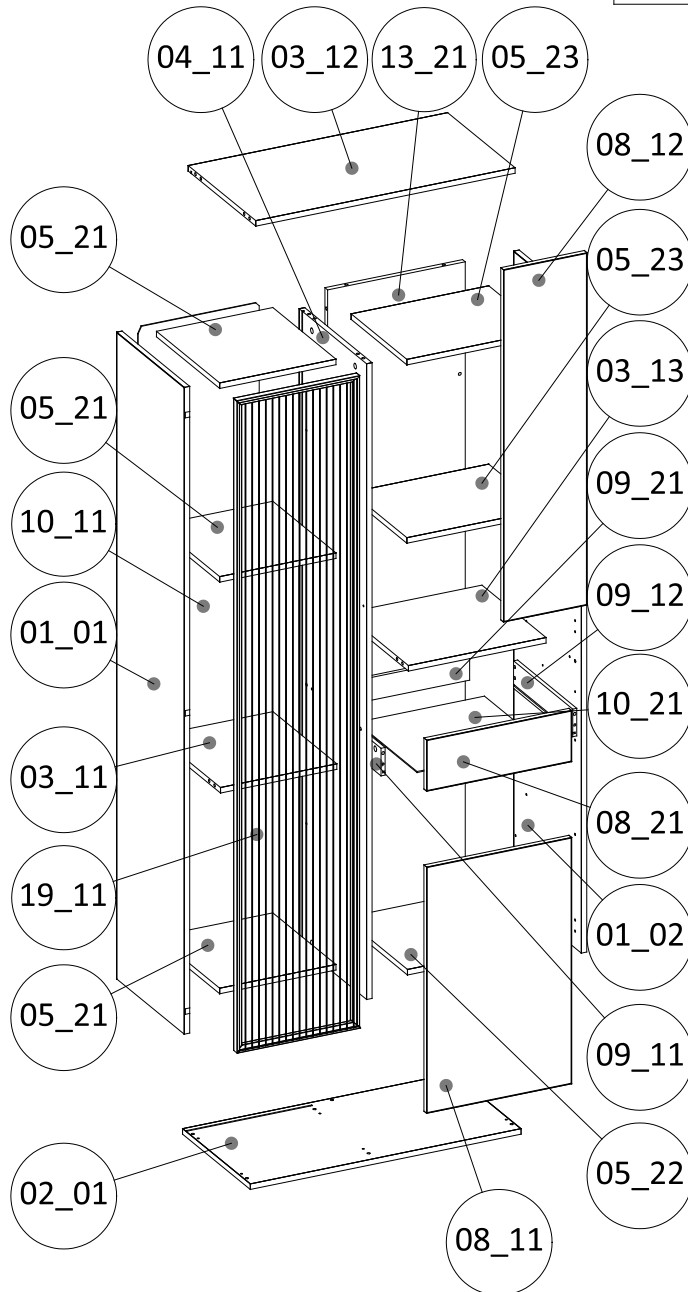

PL - WYMIARY ELEMENTÓW.  
 EN - THE DIMENSIONS OF THE ELEMENTS.  
 DE - ABMESSUNGEN DER ELEMENTE.  
 CZ - ROZMĚRY PRVKŮ.  
 SK - ROZMERY PRVKOV.  
 RU - РАЗМЕРЫ ЭЛЕМЕНТОВ.  
 SRB - DIMENZIJE ELEMENATA.  
 HR - DIMENZIJE ELEMENATA.  
 HU - A BÚTORELEMEK MÉRETEI.

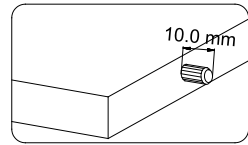
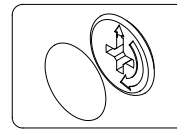
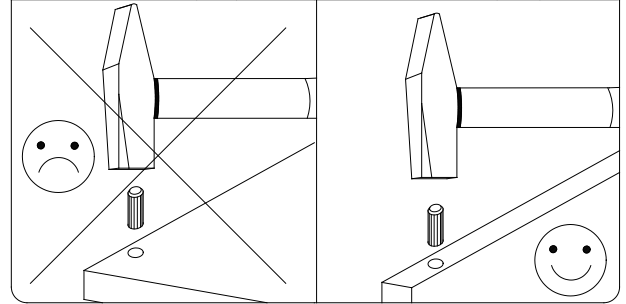
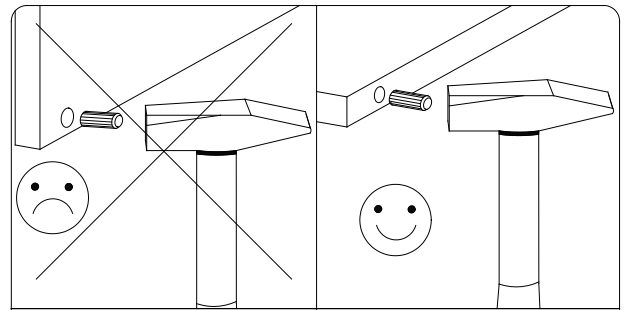
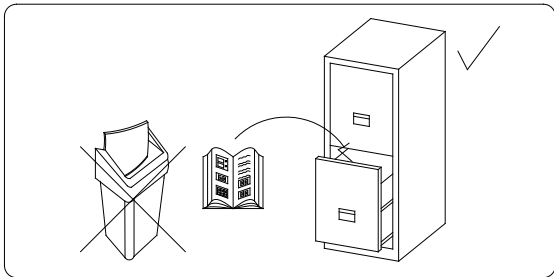
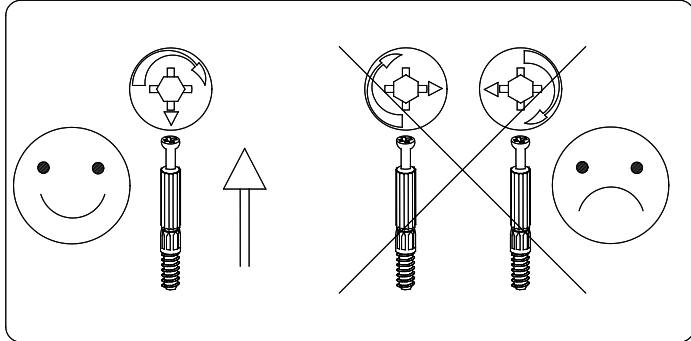
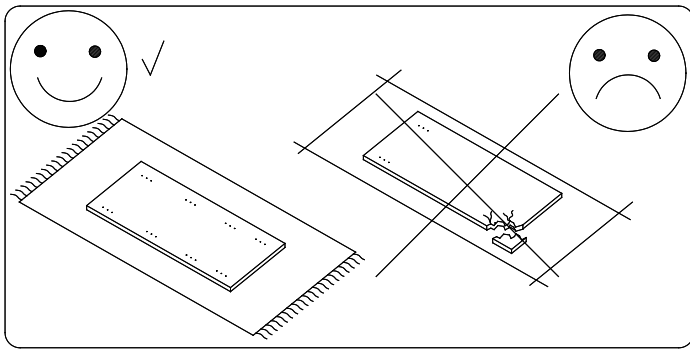
01_01	1874,0	400,0	16,0	1	3/3
01_02	1874,0	400,0	16,0	1	3/3
02_01	801,0	400,5	16,0	1	1/3
03_11	344,0	378,0	16,0	1	1/3
03_12	767,0	399,5	16,0	1	1/3
03_13	407,0	379,5	16,0	1	1/3
04_11	1842,0	399,0	16,0	1	2/3
05_21	344,0	374,0	16,0	3	1/3
05_22	407,0	375,0	16,0	1	1/3
05_23	407,0	330,0	16,0	2	1/3
08_11	713,5	429,0	16,0	1	2/3
08_12	1020,5	247,0	16,0	1	2/3
08_21	429,0	148,0	16,0	1	2/3
09_11	350,0	80,0	12,0	1	2/3
09_12	350,0	80,0	12,0	1	2/3
09_21	366,0	66,0	12,0	1	2/3
10_11	1856,0	358,0	3,0	1	3/3
10_21	378,0	357,0	3,0	1	3/3
13_21	1842,0	407,0	16,0	1	2/3
19_11	1887,0	365,0	20,5	1	3/3

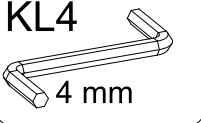
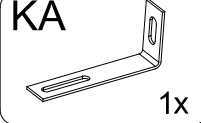
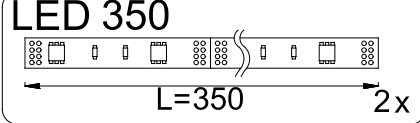
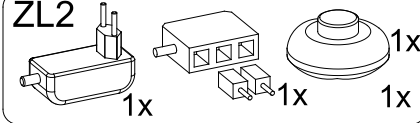
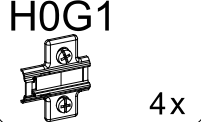
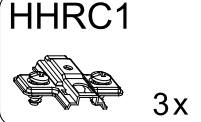

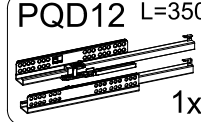
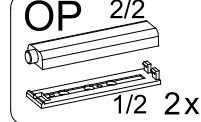
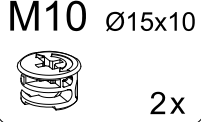
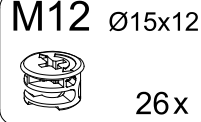
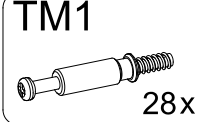
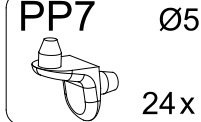
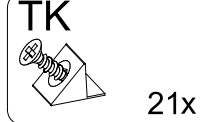
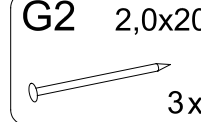
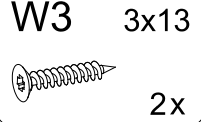
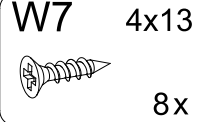
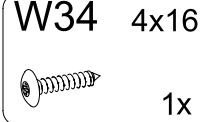
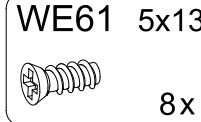

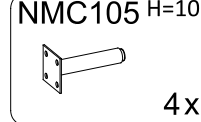
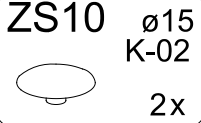
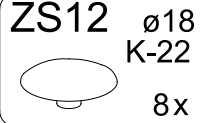
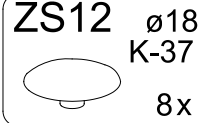
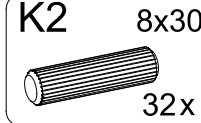
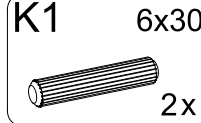
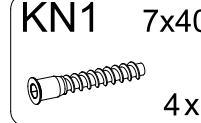
<b>KL4</b> 4 mm 	<b>KA</b> 1x 	<b>LED 350</b> L=350 2x 	<b>ZL2</b> 1x 
<b>H0G1</b> 4x 	<b>HHRC1</b> 3x 	<b>ZGP1</b> 4x 	<b>ZHRC1</b> 3x 
<b>PQD12 L=350</b> 1x 	<b>OP 2/2</b> 1/2 2x 	<b>M10</b> Ø15x10 2x 	<b>M12</b> Ø15x12 26x 
<b>TM1</b> 28x 	<b>PP7</b> Ø5 24x 	<b>TK</b> 21x 	<b>G2</b> 2,0x20 3x 
<b>W3</b> 3x13 2x 	<b>W7</b> 4x13 8x 	<b>W34</b> 4x16 1x 	<b>WE61</b> 5x13 8x 
<b>WE73</b> 6,3x13 16x 	<b>NMC105 H=105</b> 4x 	<b>ZS10</b> Ø15 K-02 2x 	<b>ZS12</b> Ø18 K-22 8x 
<b>ZS12</b> Ø18 K-37 8x 	<b>K2</b> 8x30 32x 	<b>K1</b> 6x30 2x 	<b>KN1</b> 7x40 4x 

Proszę sprawdzić kompletność okuć przed montażem  
Bitte überprüfen Sie die Vollständigkeit der Fittings vor der Montage  
Please check the completeness of the fittings before assembly  
Пожалуйста, проверьте комплектность фурнитуры перед установкой

Prosim zkontrolujte úplnosť konektorů před instalací  
Prosim skontrolujte úplnosť konektorov pred inštaláciou  
Prije montaže provjerite cjelovitost okova  
Pre postavljanja proverite kompletnost okova  
Kérjük, ellenőrizze a szerelvények teljességét a szerelés előtt

- 1**
- K2** 8x30 2x
  - M12** Ø15x12 2x
  - PP7** Ø5 6x

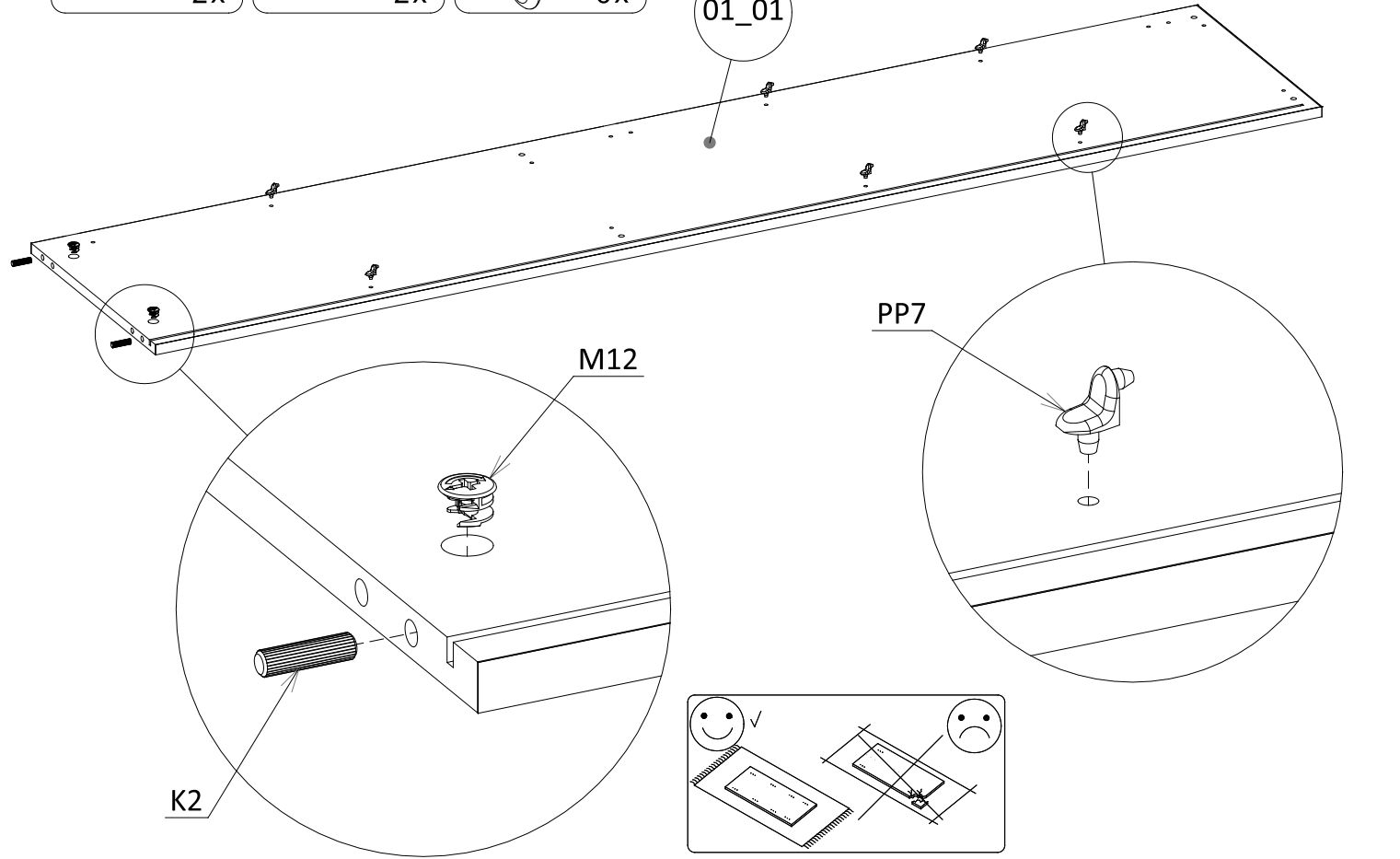

- 2**
- TM1** 4x
  - HHRC1** 3x

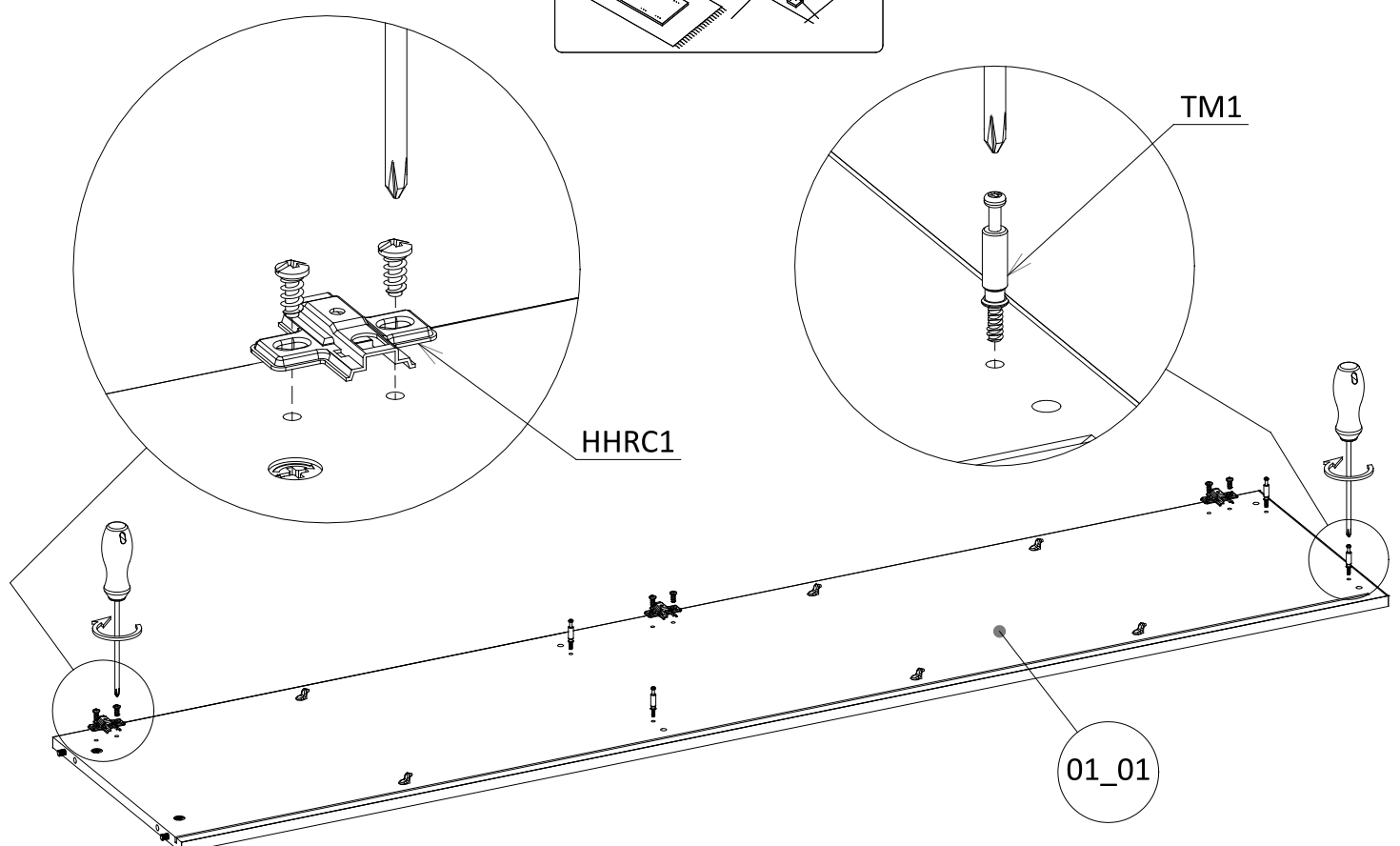
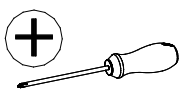
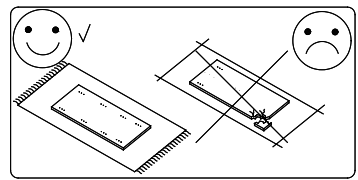

3

- K2** 8x30 2x
- M12** Ø15x12 2x
- PP7** Ø5 6x

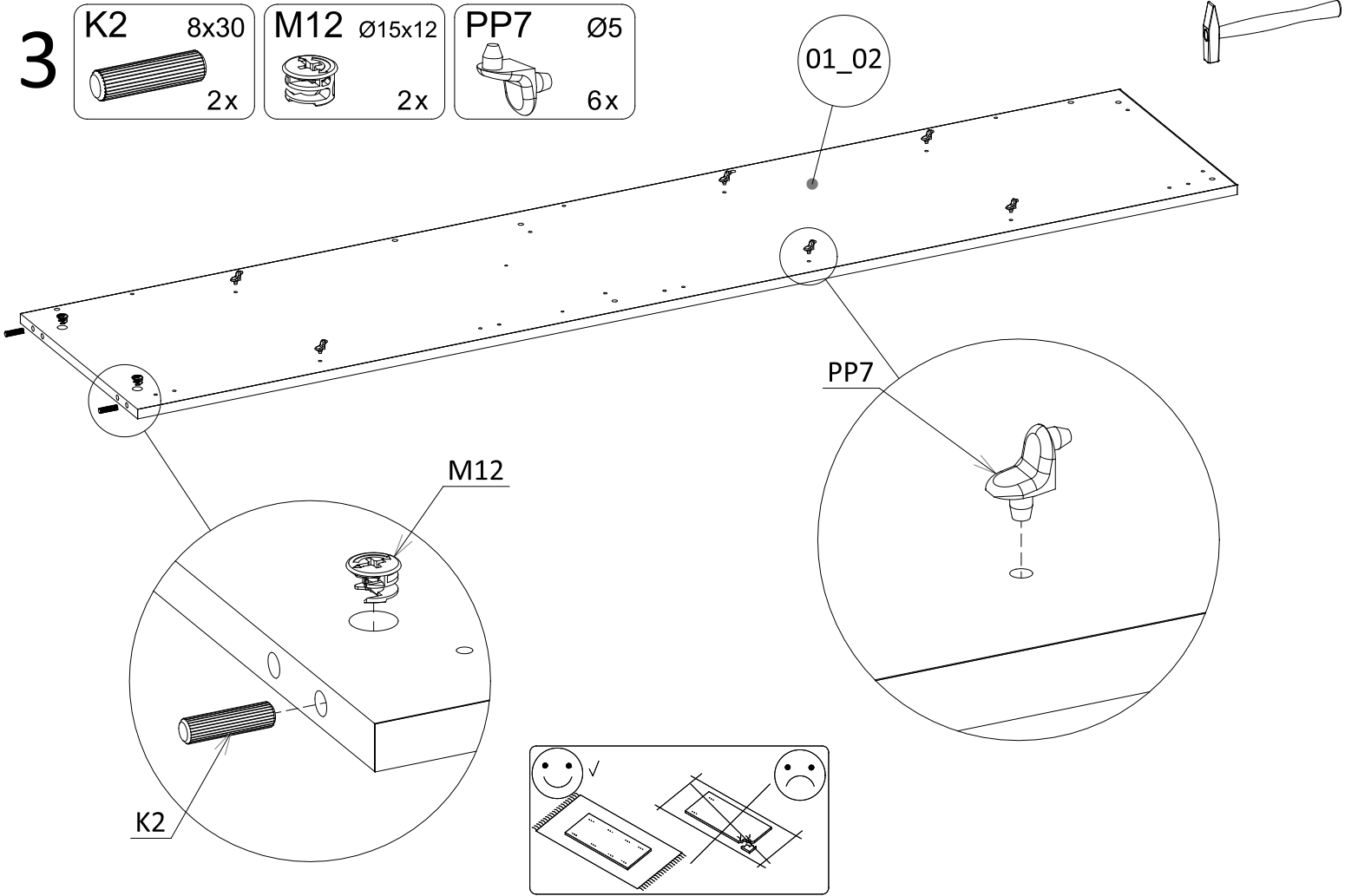

4

- TM1** 7x
- H0G1** 4x
- PQD12** L=350 1x
- WE61** 5x13 2x

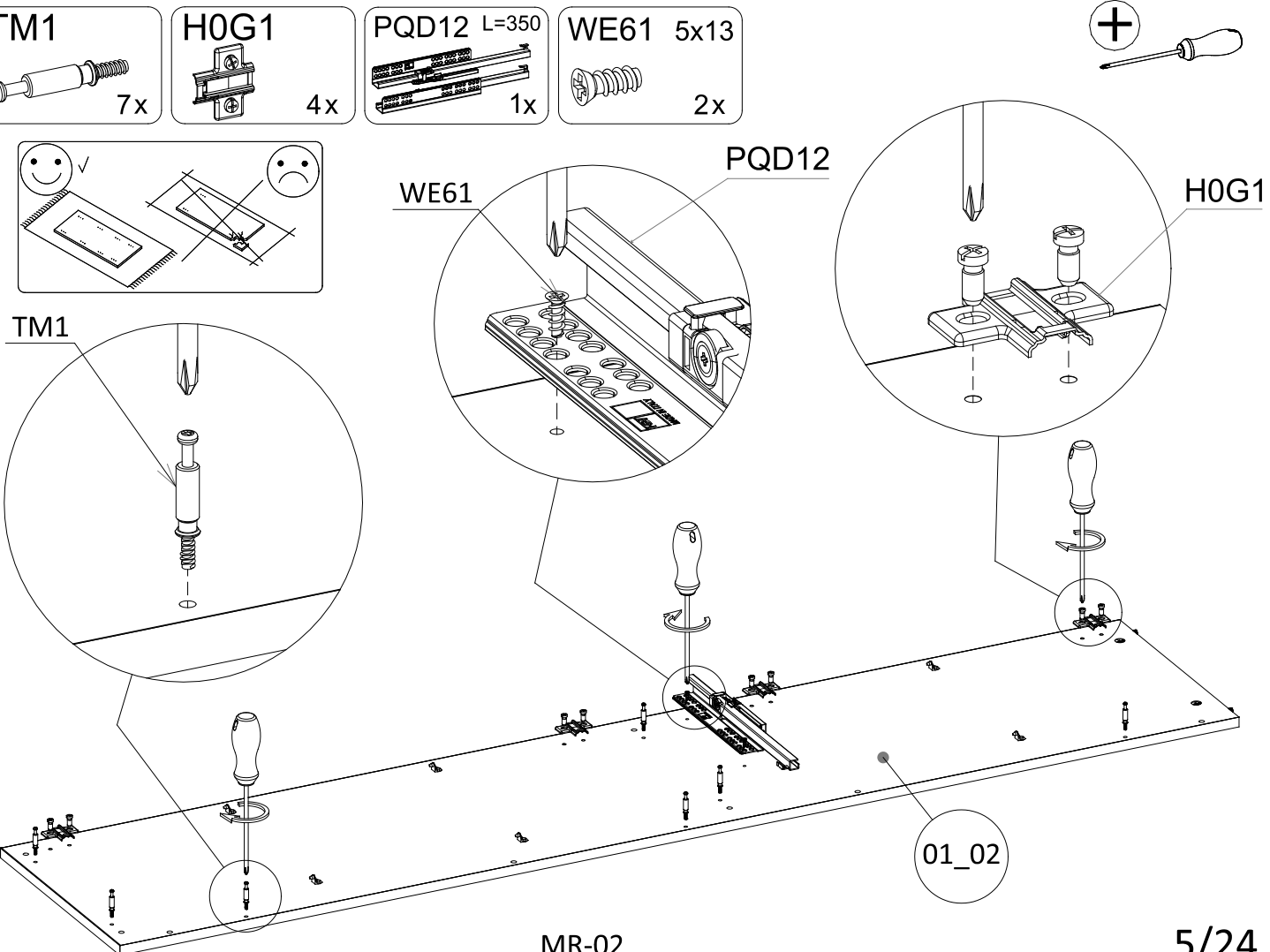

5

NMC105 H=105  
4x

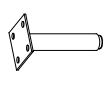

WE73 6,3x13  
16x

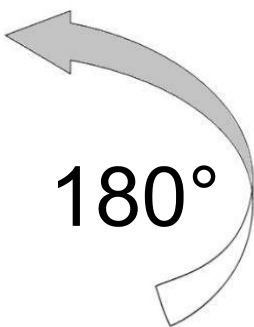
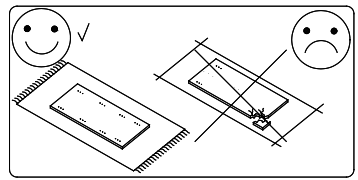
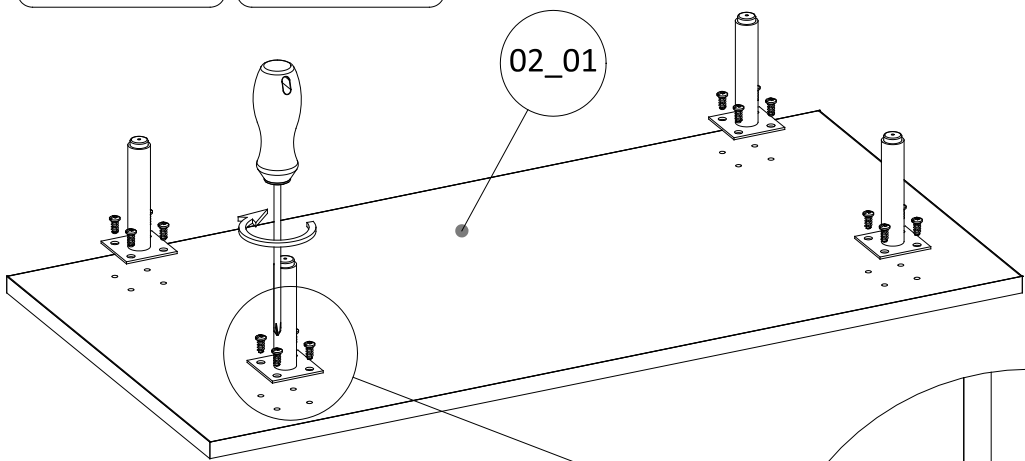
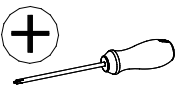

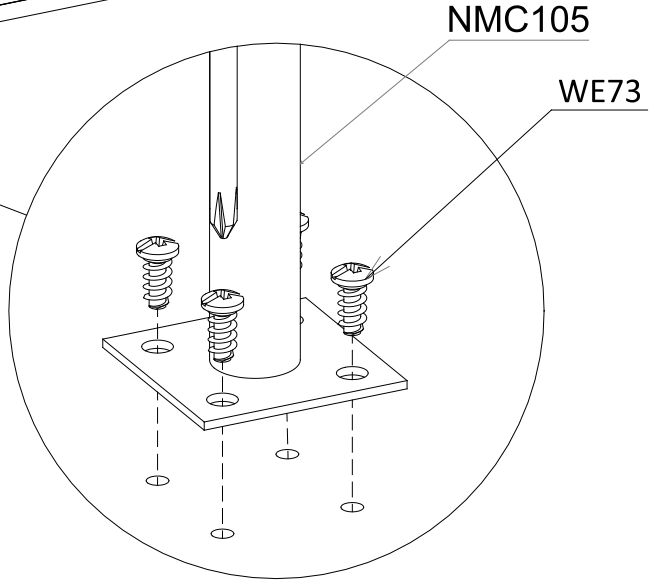

180°

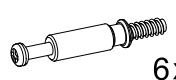
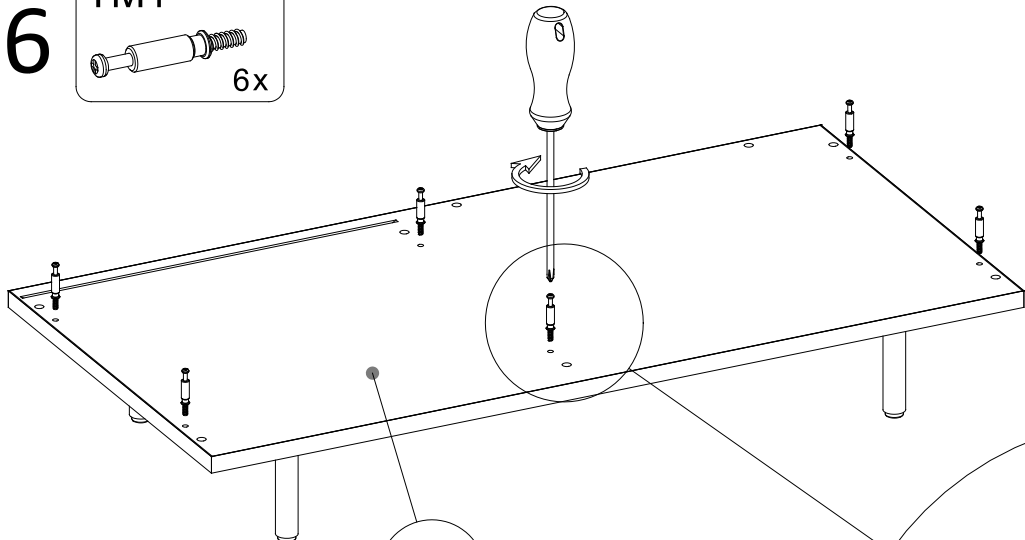
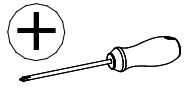

6

TM1  
6x



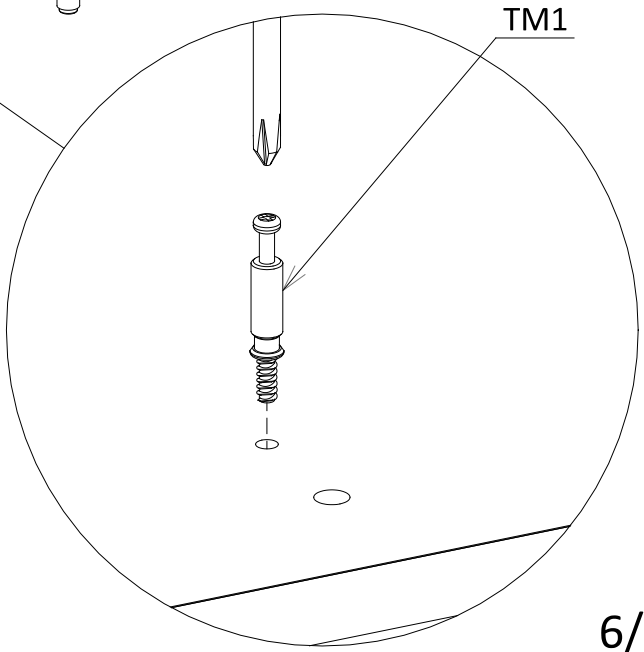

02\_01

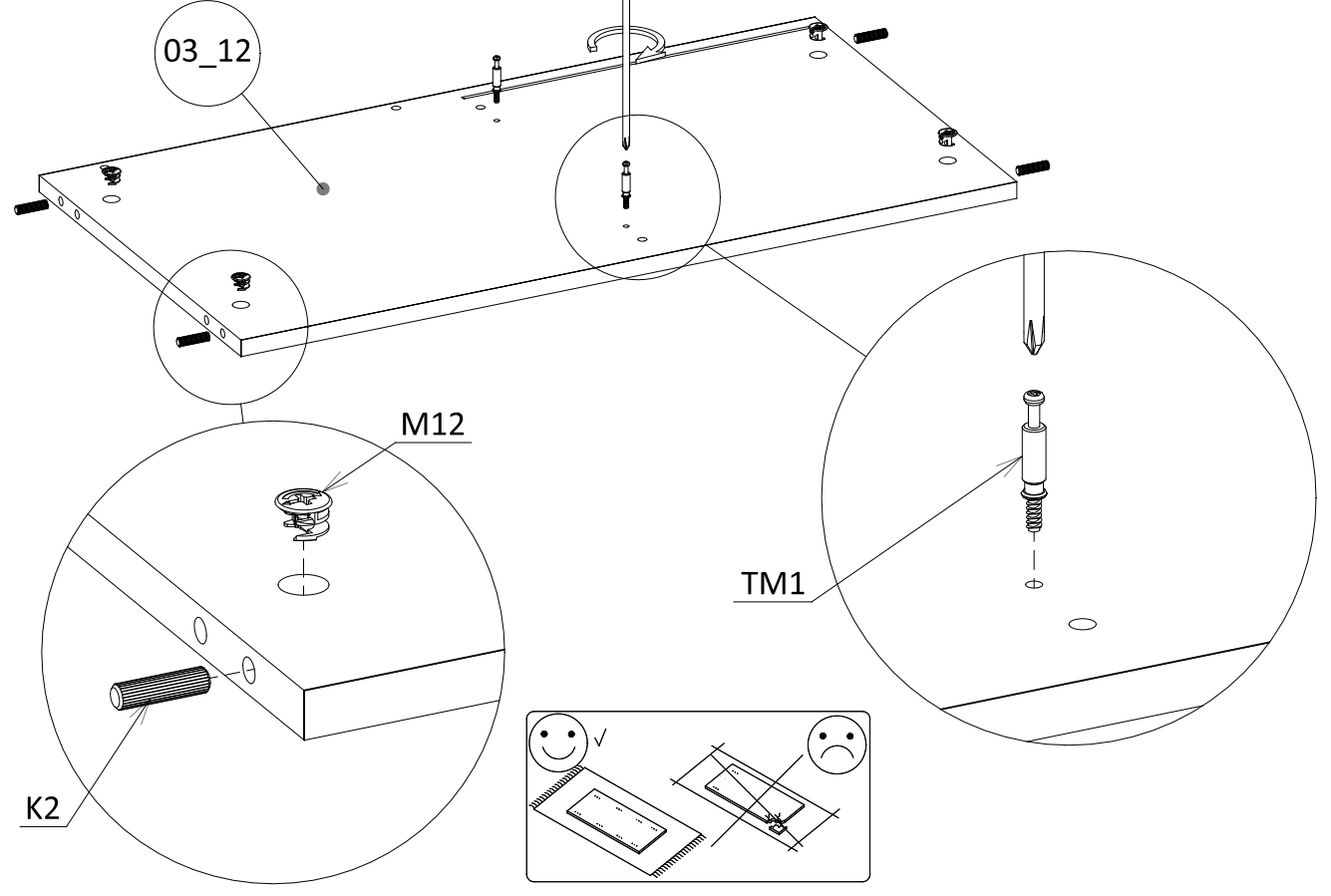
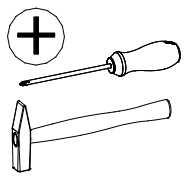

7

- K2** 8x30 4x
- M12** Ø15x12 4x
- TM1** 2x



8

- K2** 8x30 8x
- M12** Ø15x12 8x

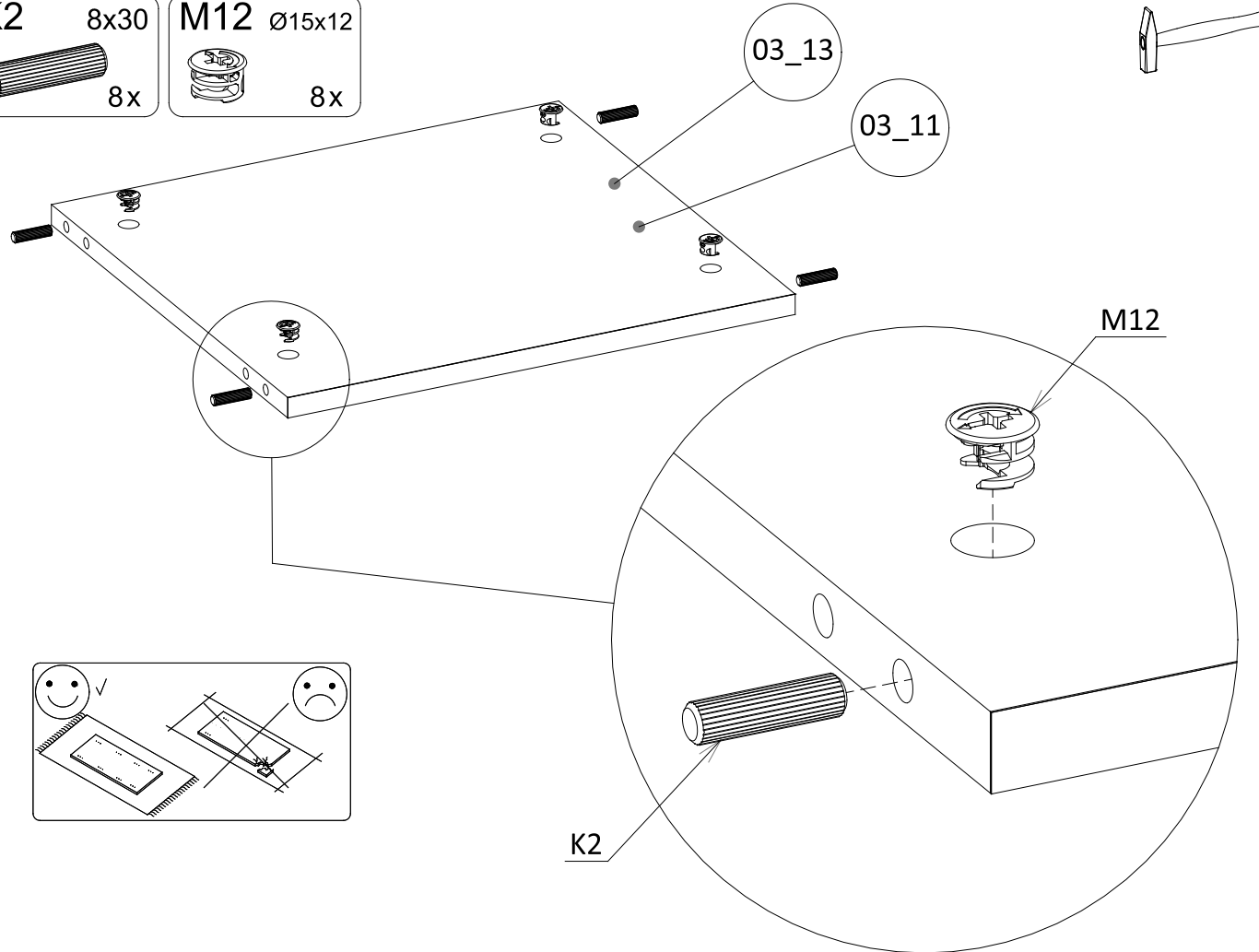

9

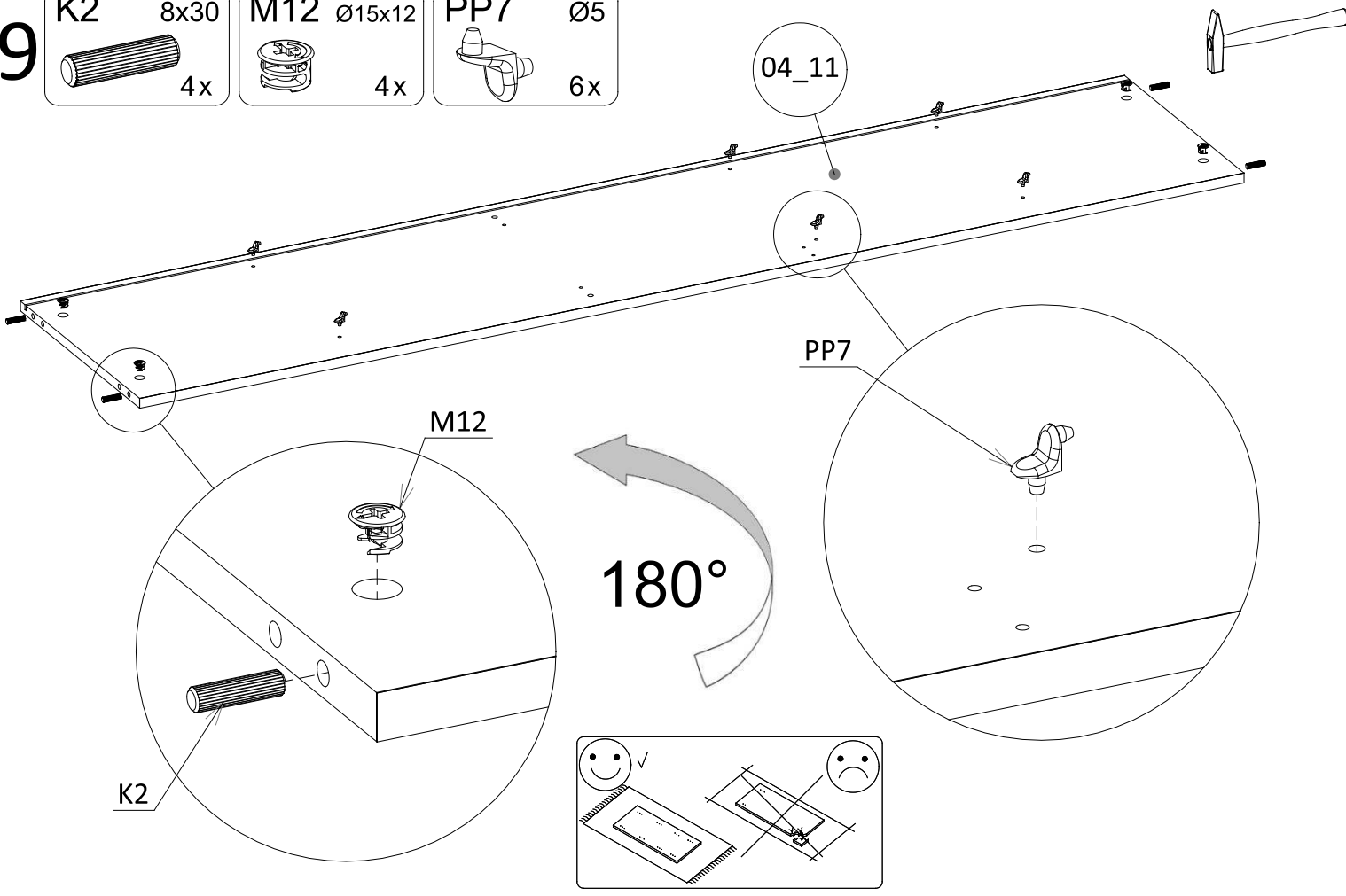
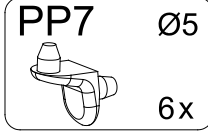
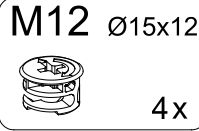
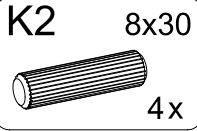

10

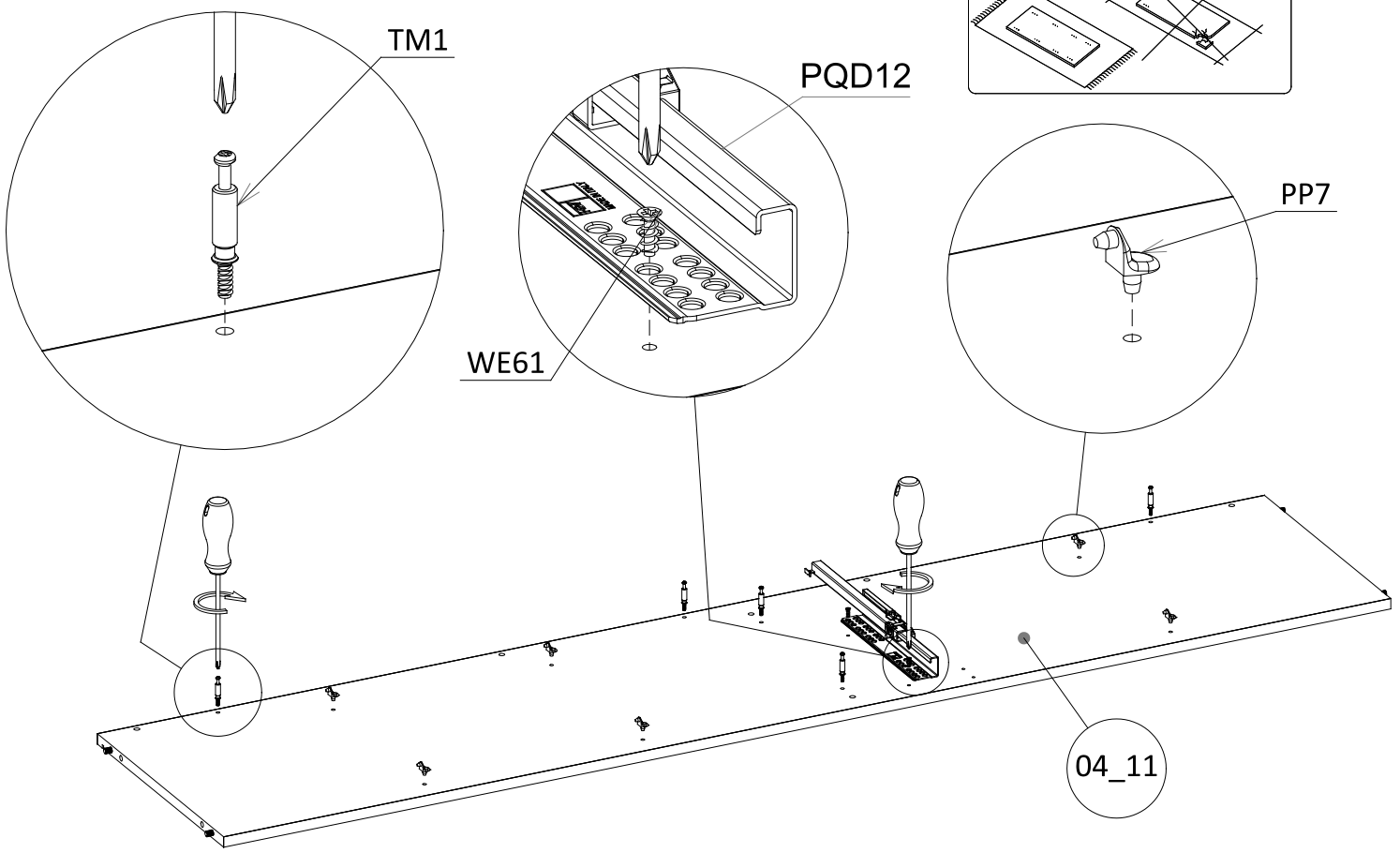
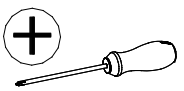
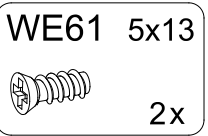
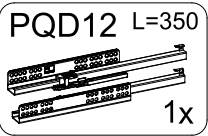
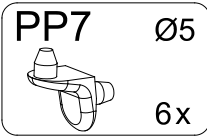
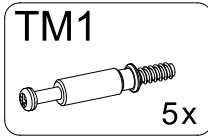



# 11

- K2** 8x30 12x
- M12** Ø15x12 6x

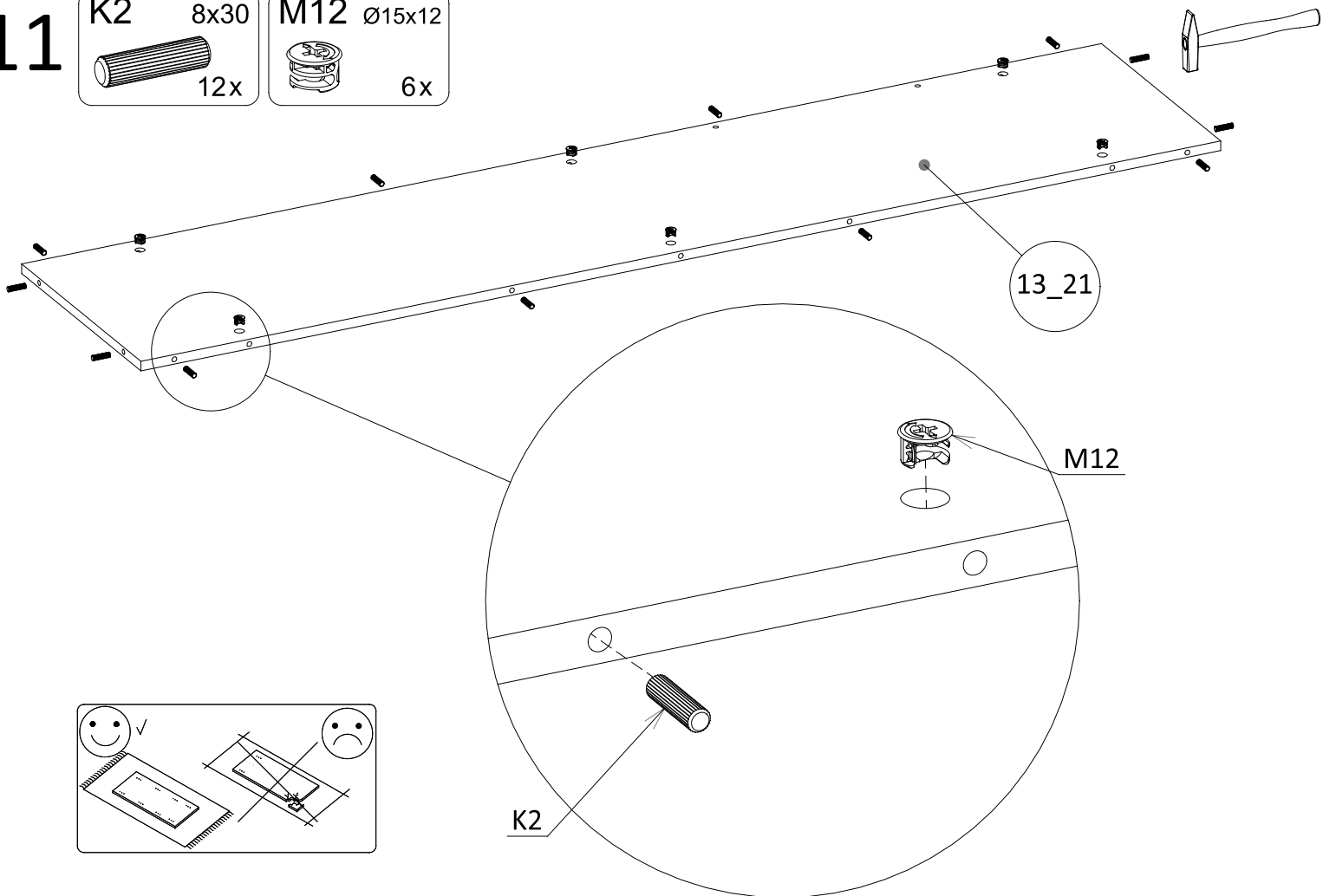

# 12

- ZS12** ø18 K-22 2x

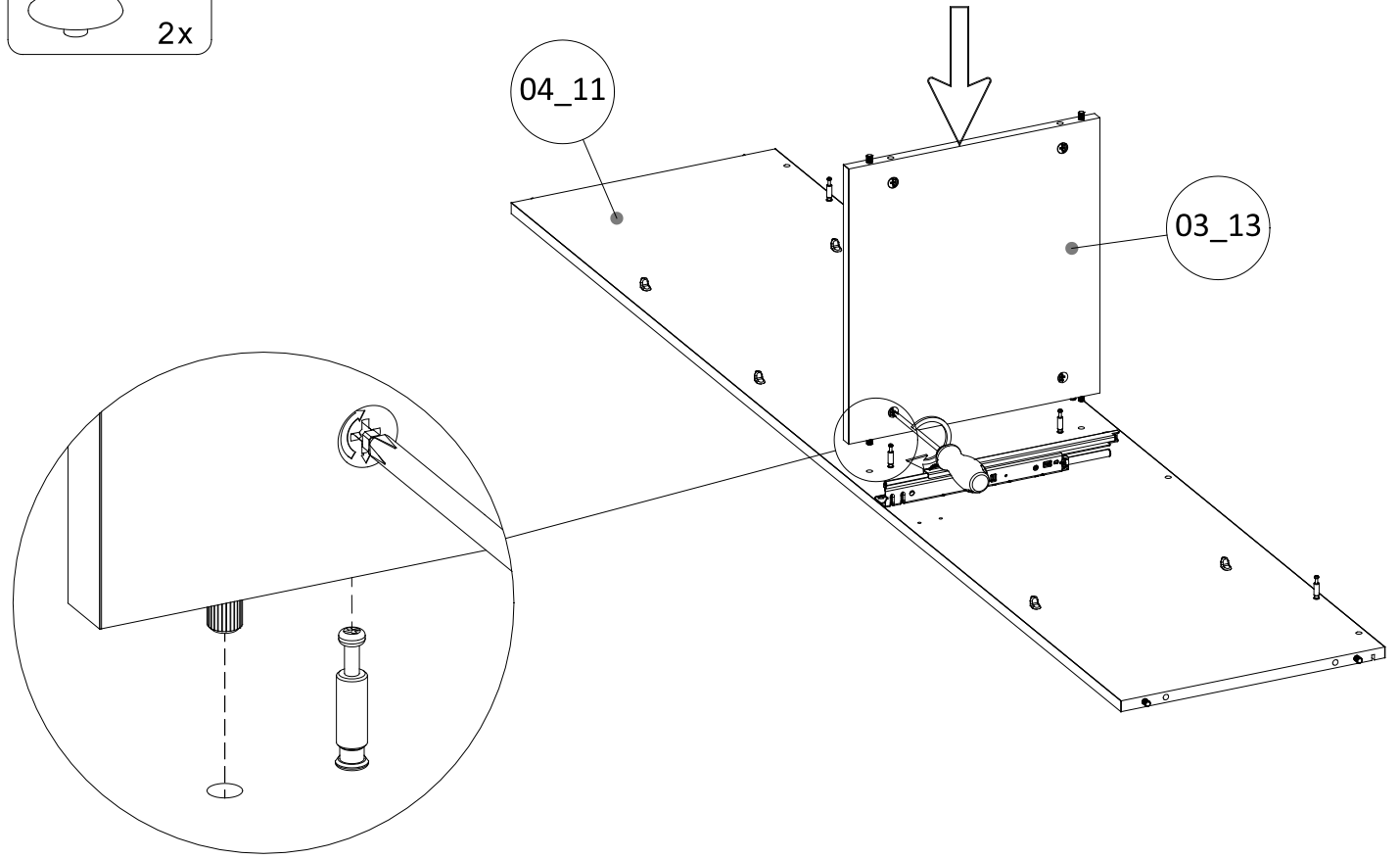
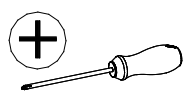

# 13

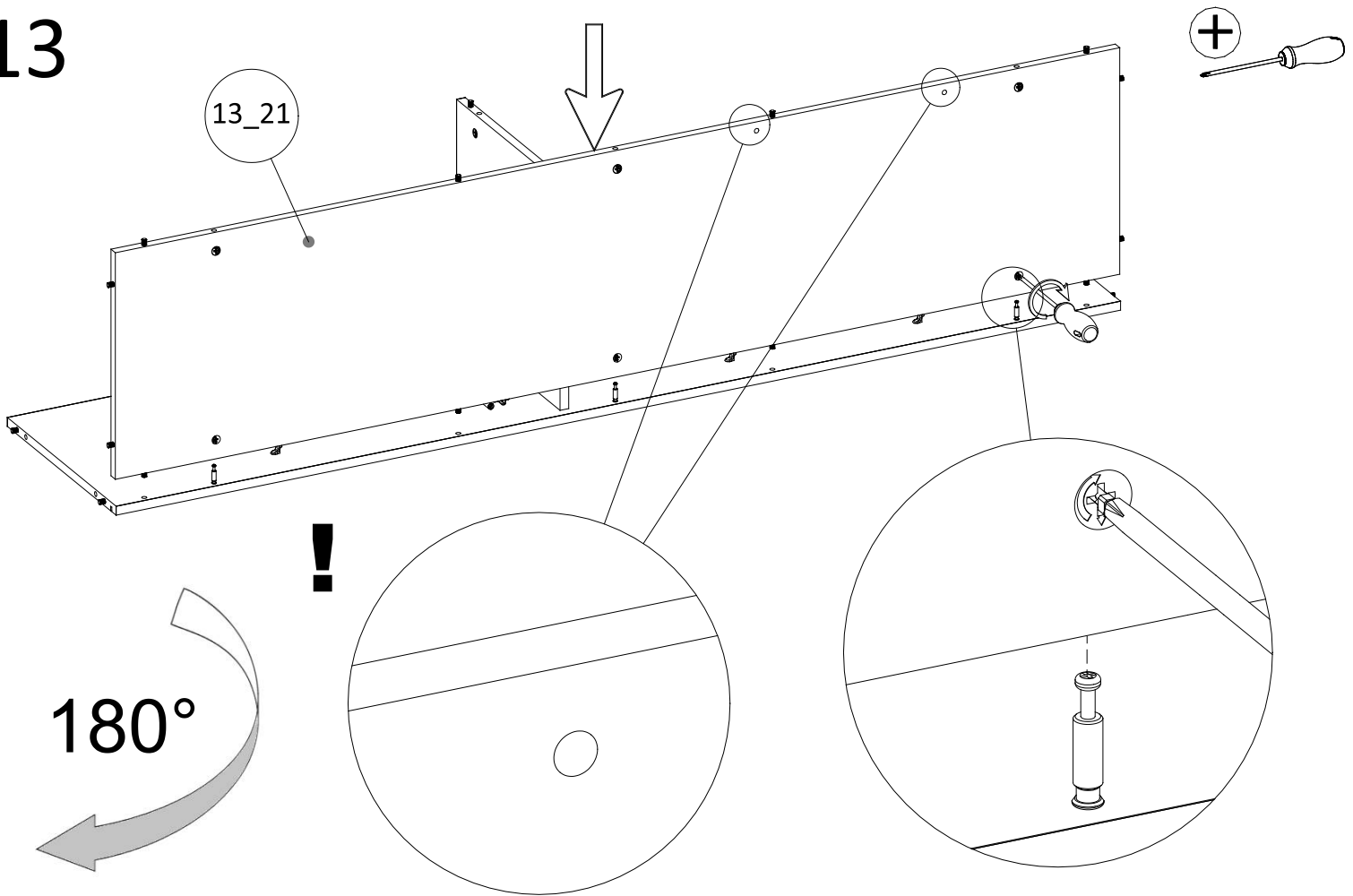

# 14

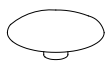
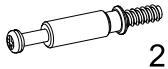
- |   |      |   |
|---|------|---|
| ZS12  | ø18  | TM1   |
|  | K-37 |  |
| 2x  |      | 2x  |

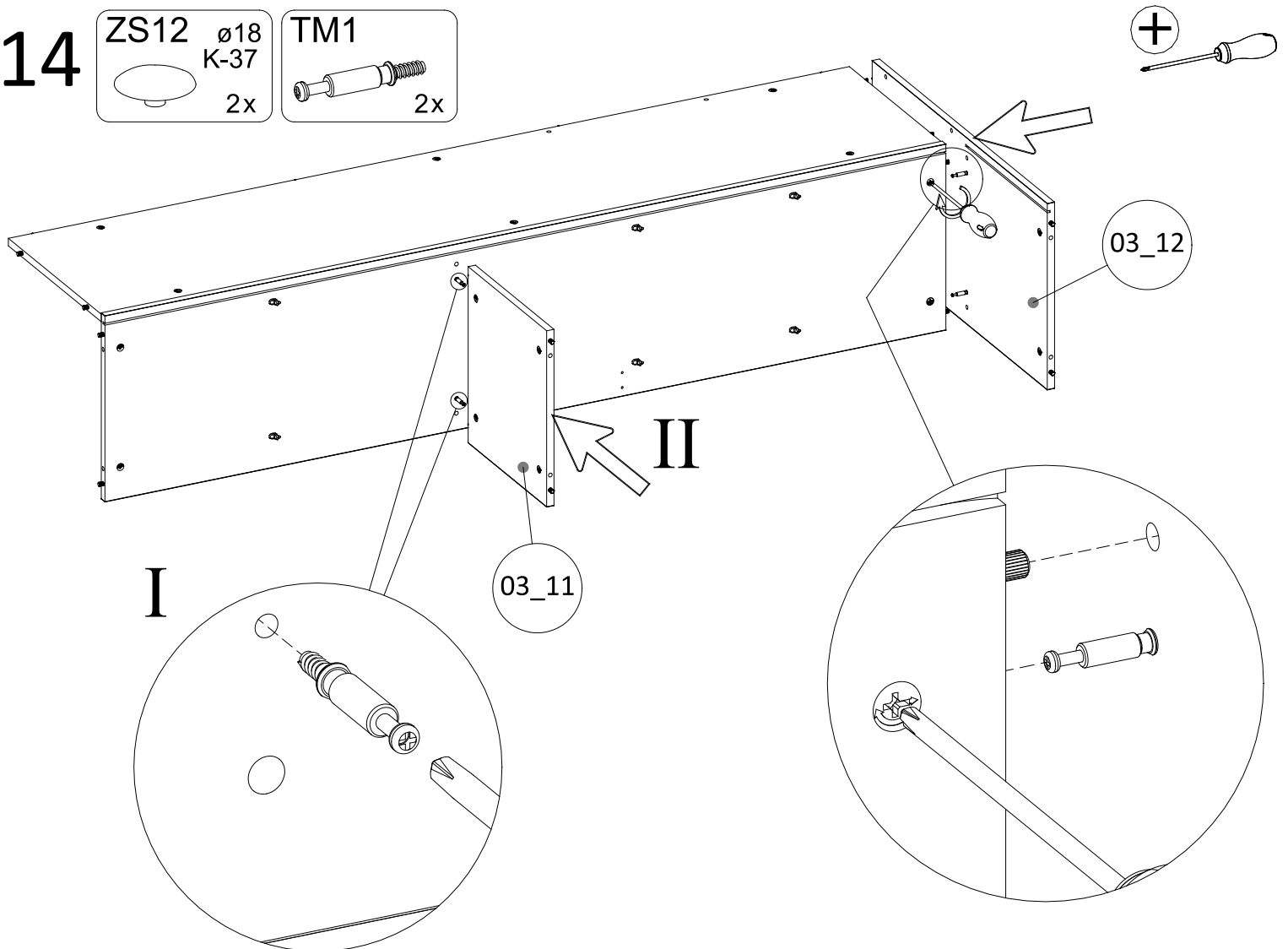

15

ZS12  $\varnothing 18$   
K-22  
2x

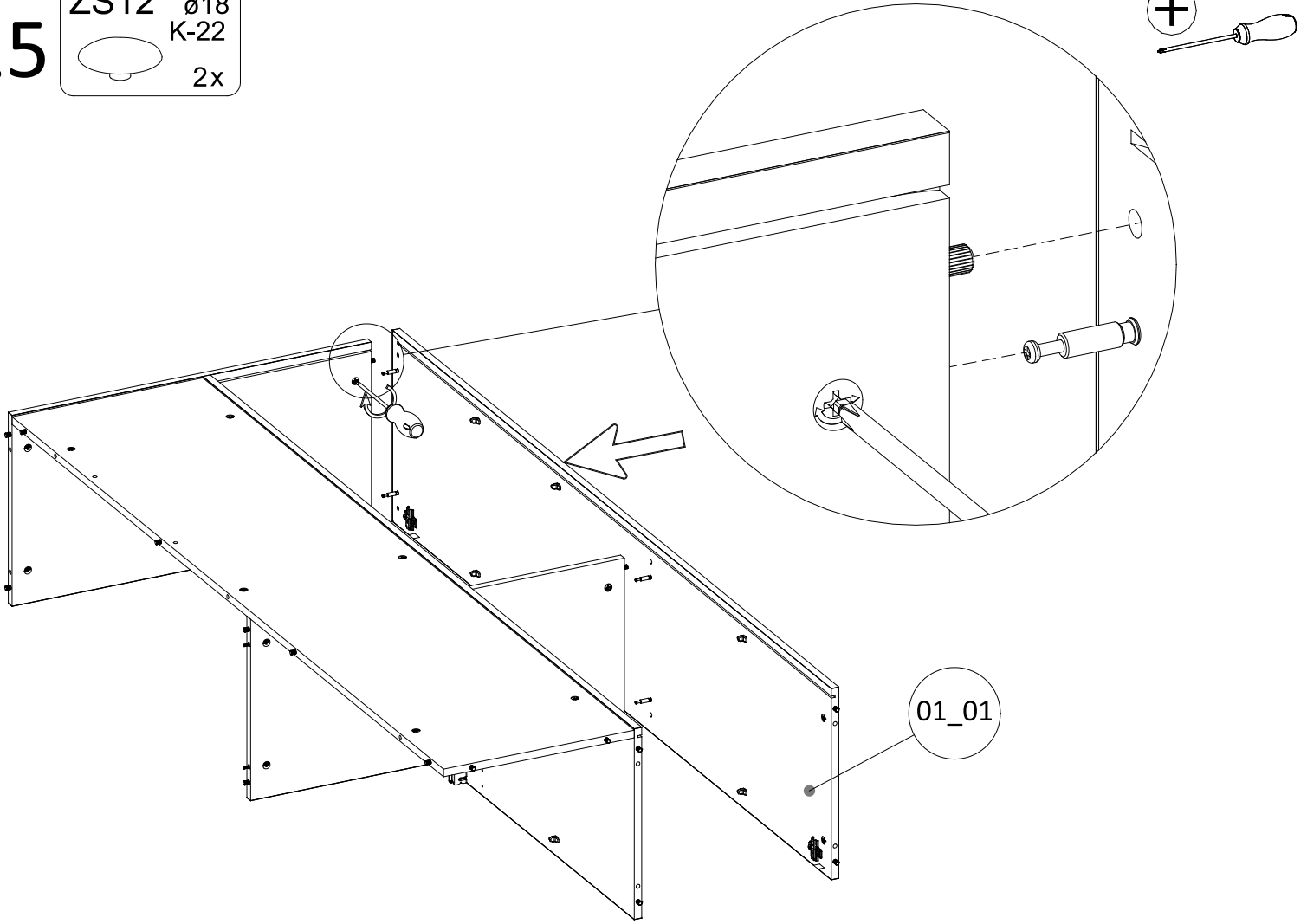

16

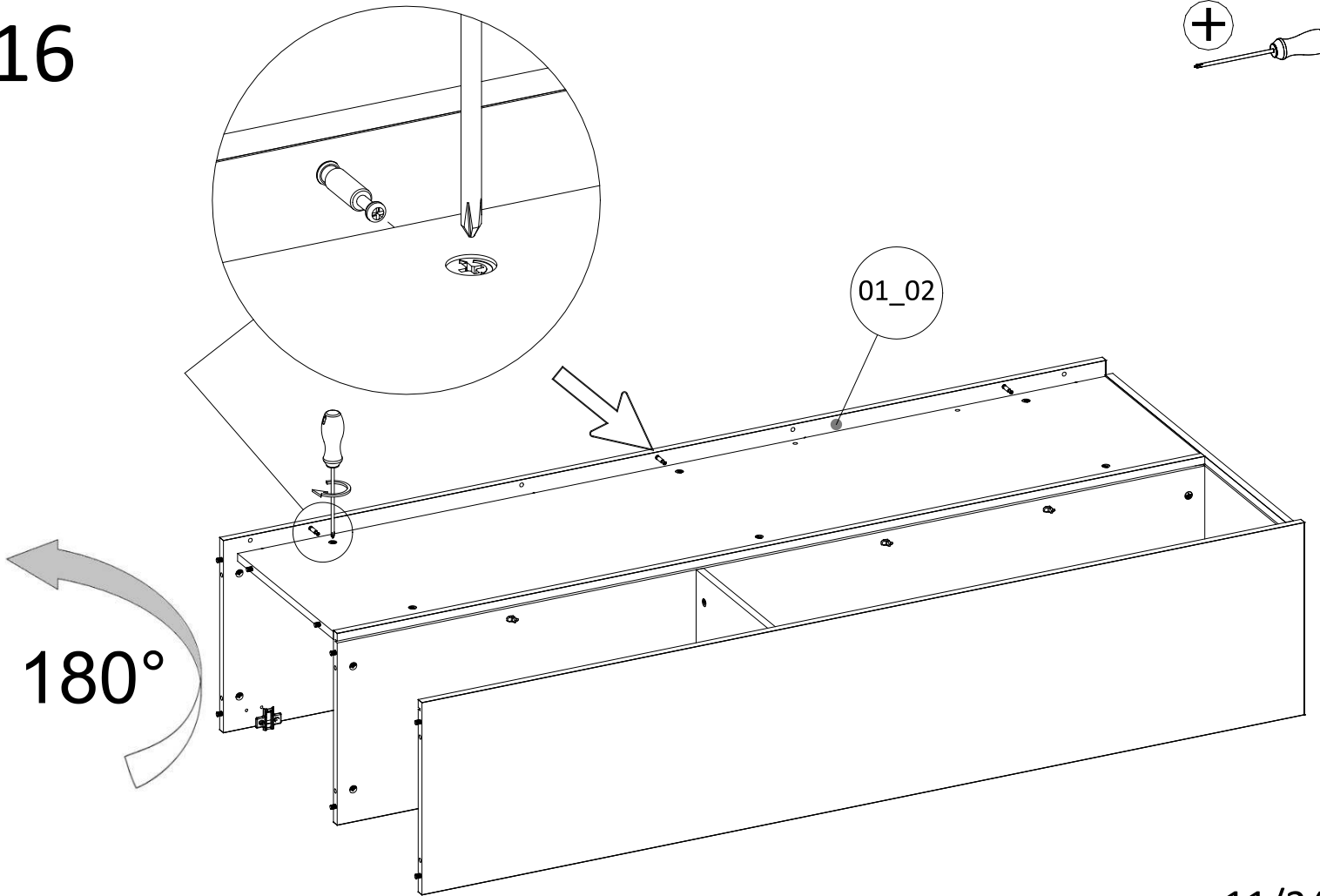
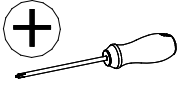

MR-02

11/24

17

ZS12  $\phi 18$   
K-22  
4x

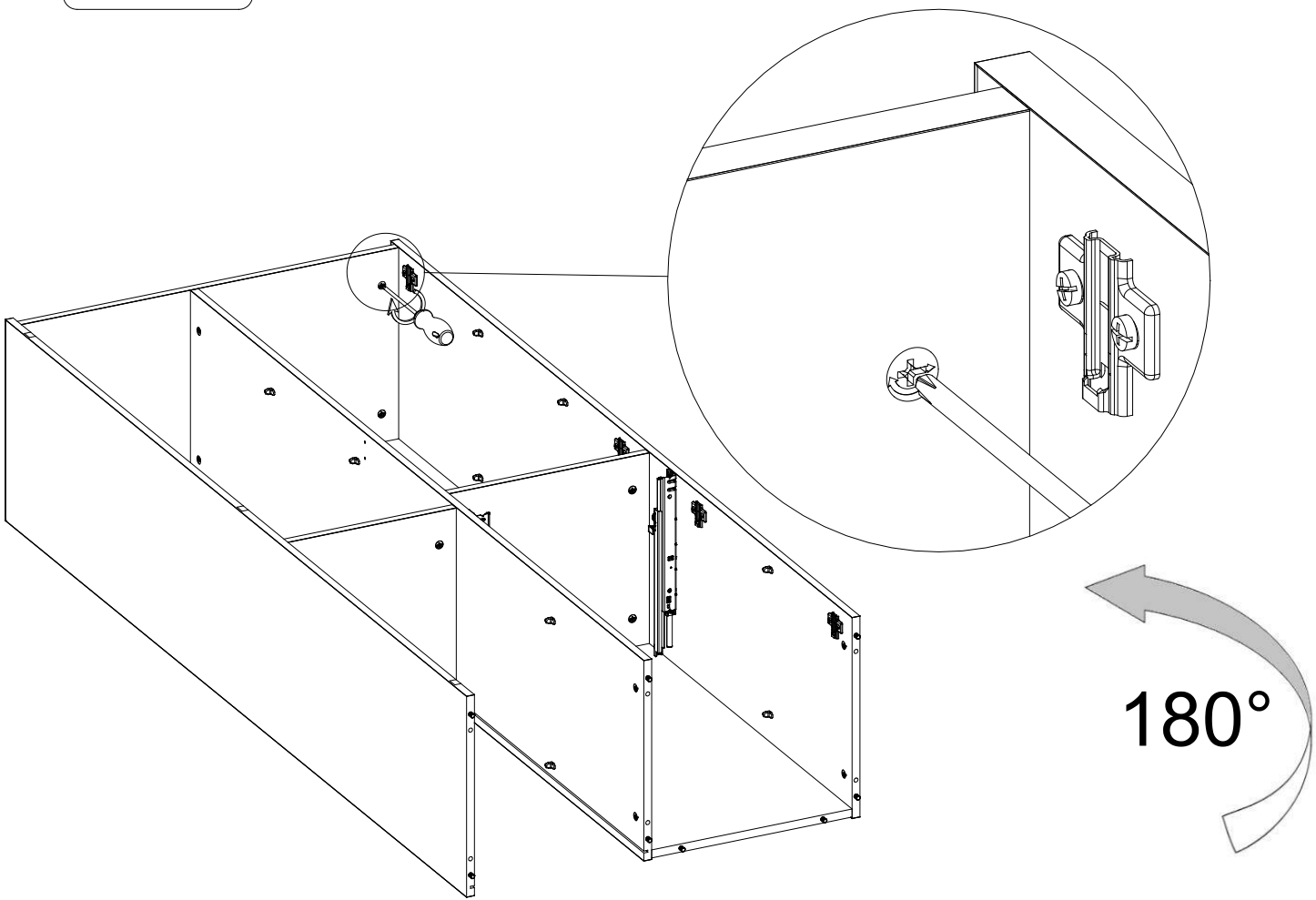
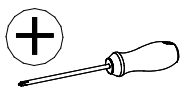

18

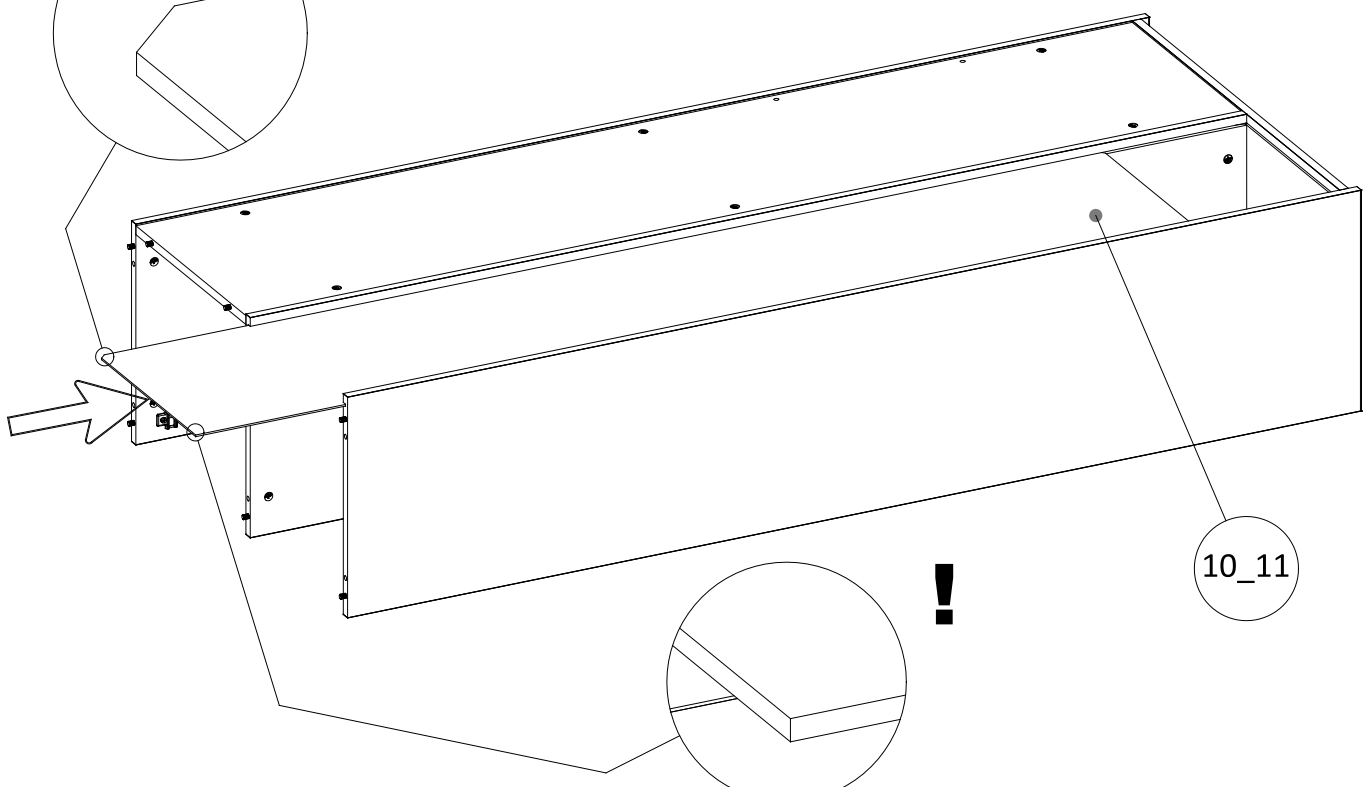
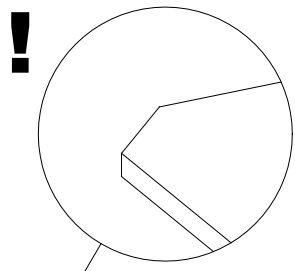

MR-02

12/24

# 19

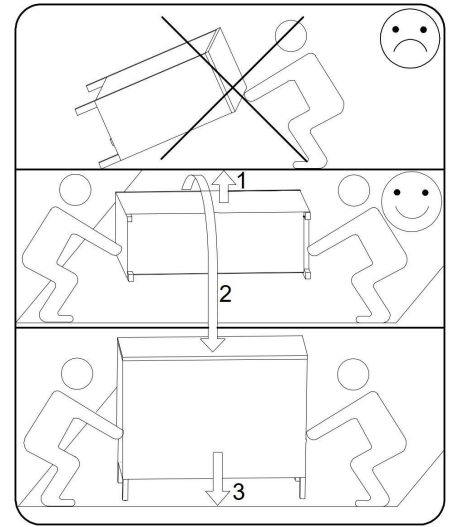
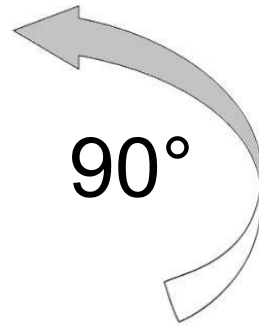
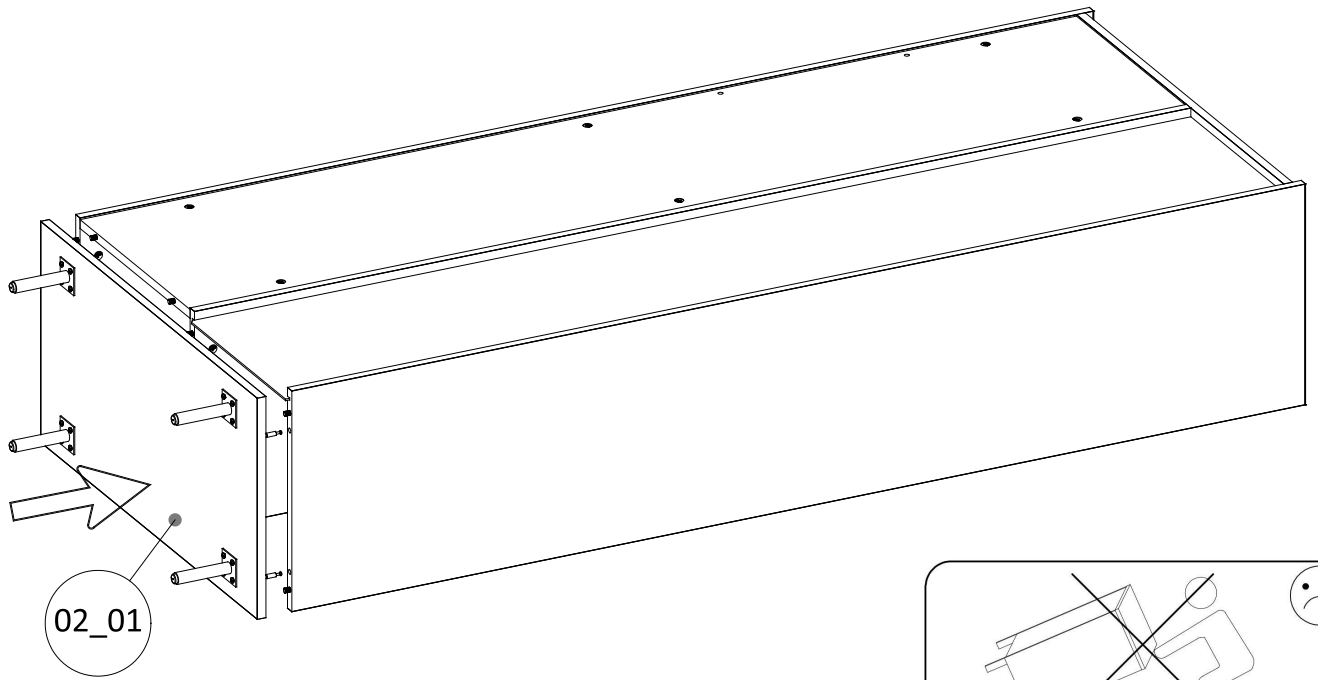

# 20

ZS12 ø18  
K-37  
6x

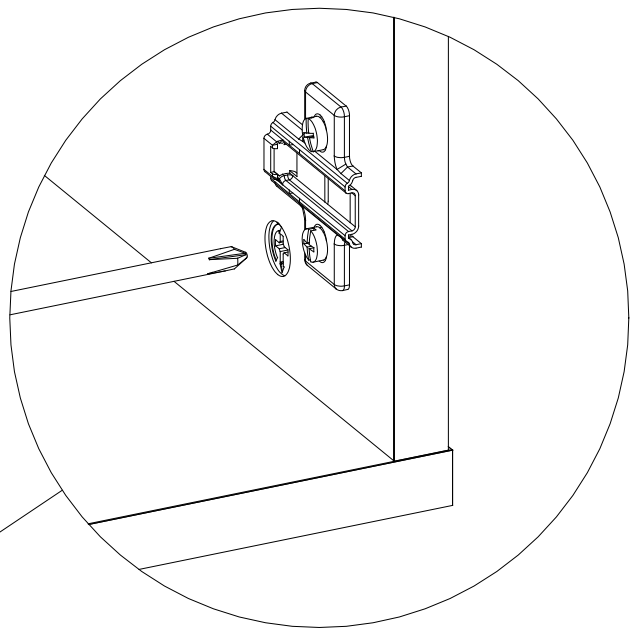
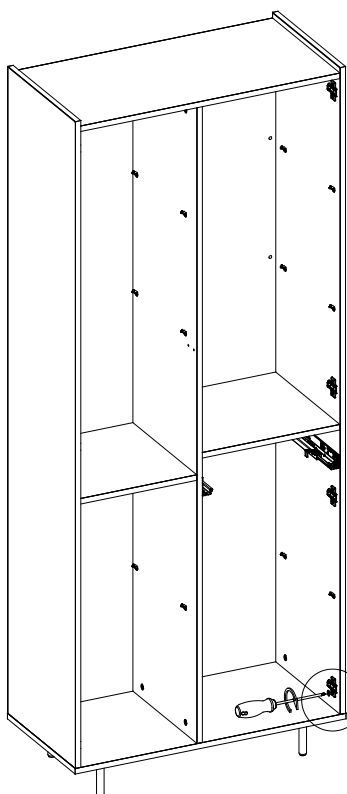
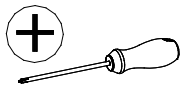

# 21

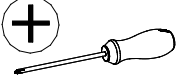
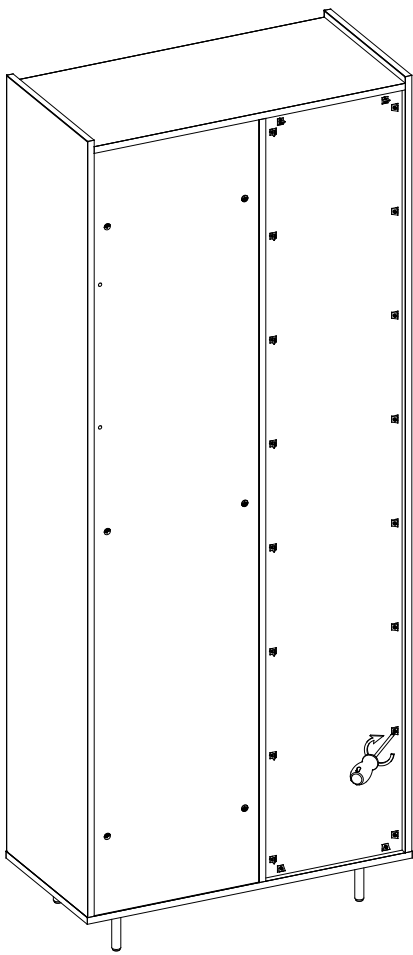
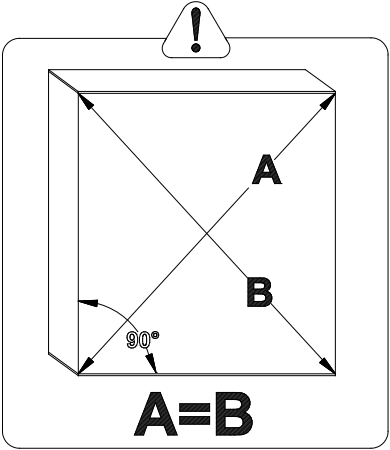
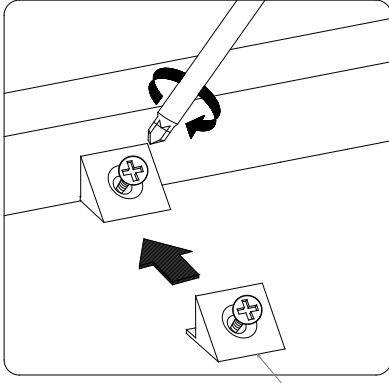
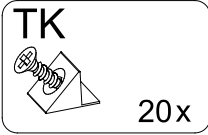

# 22

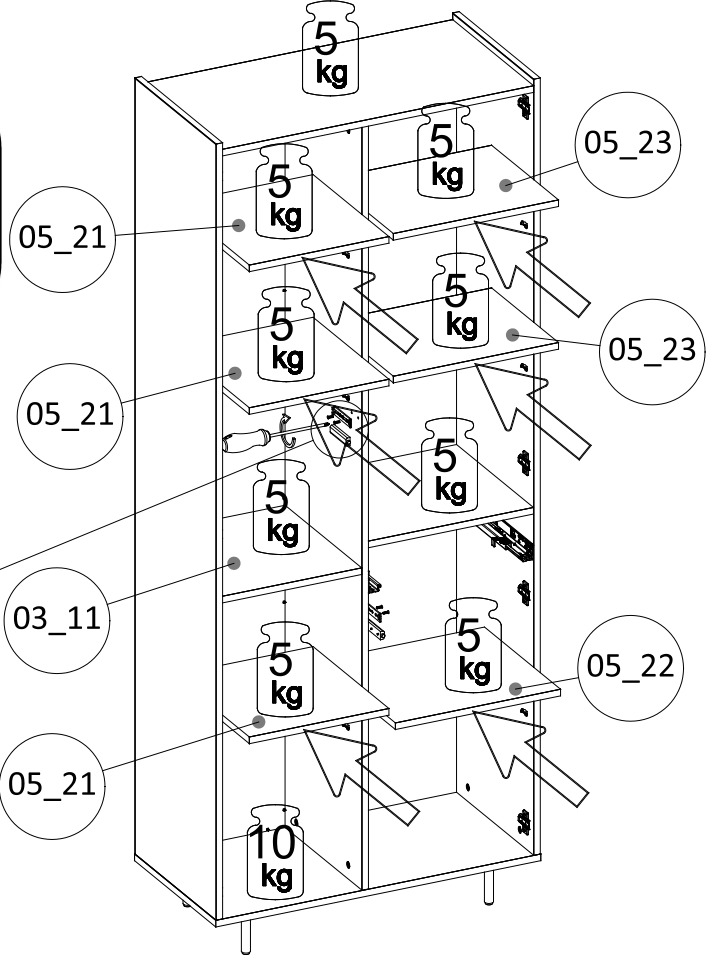
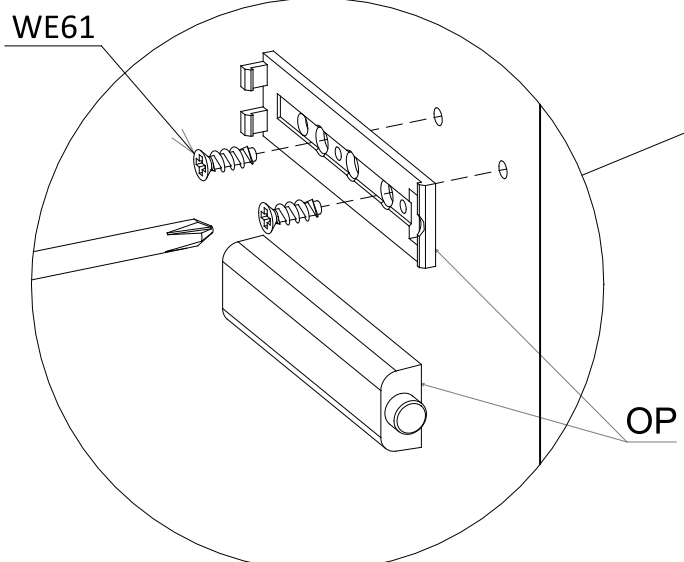
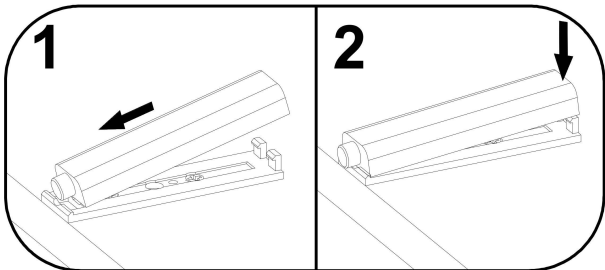
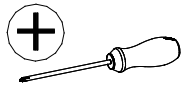
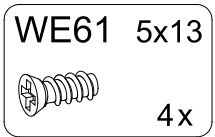
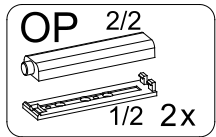

23

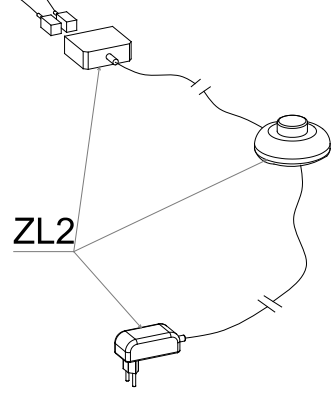
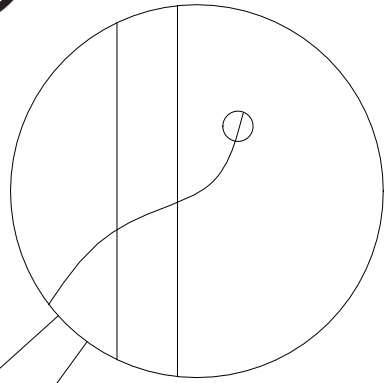
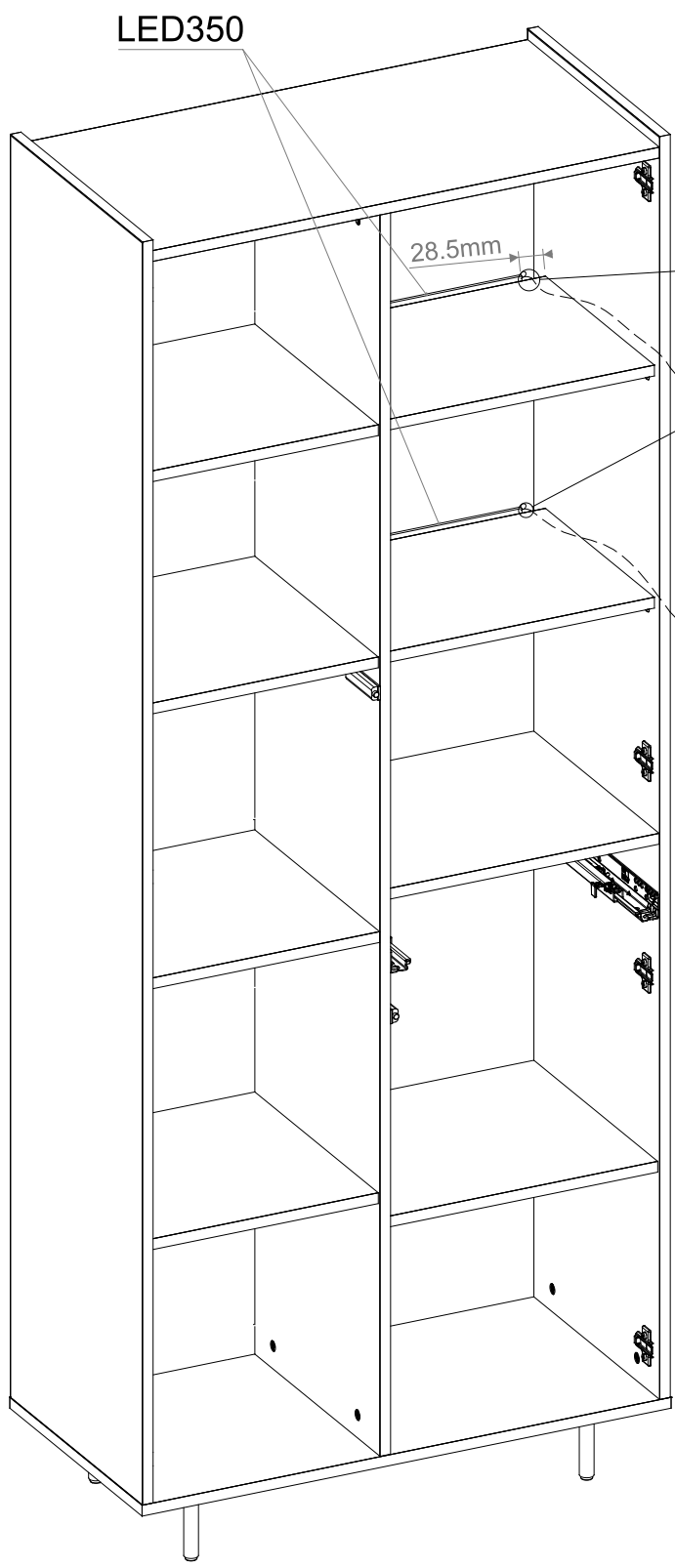
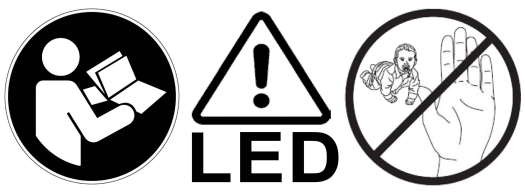
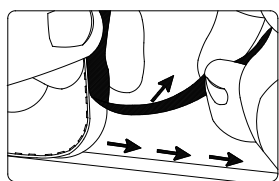
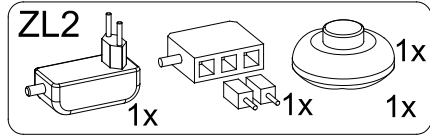
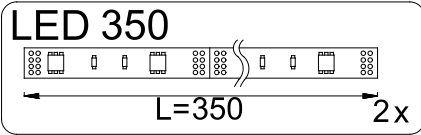

24

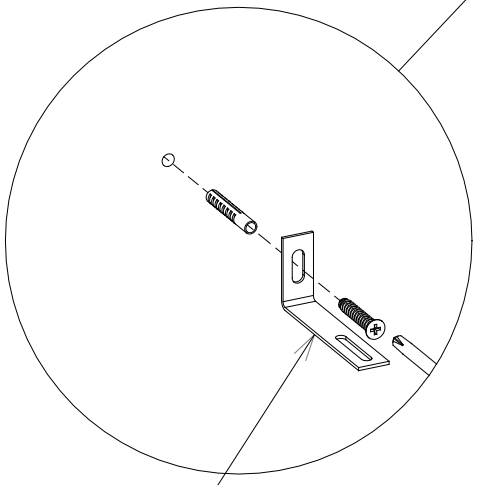
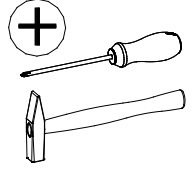
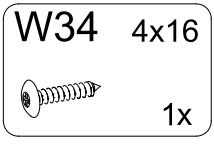
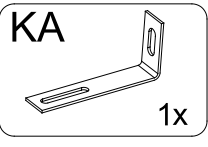

KA

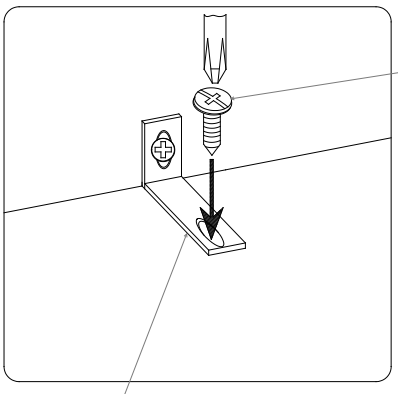

W34

KA

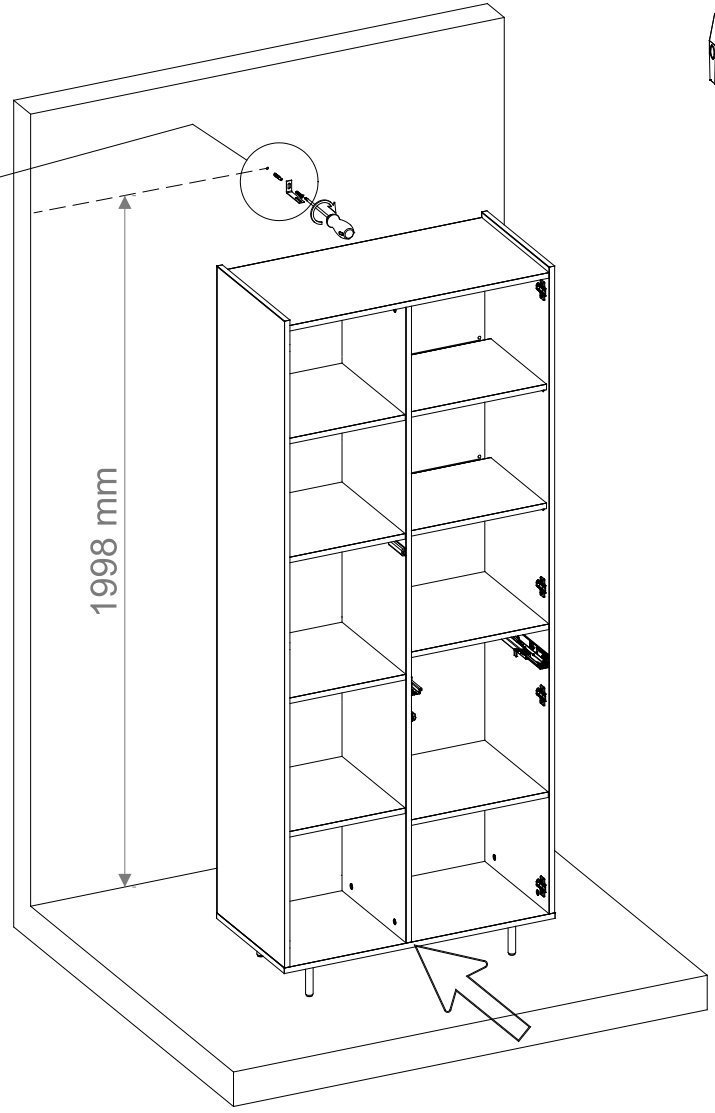

1998 mm

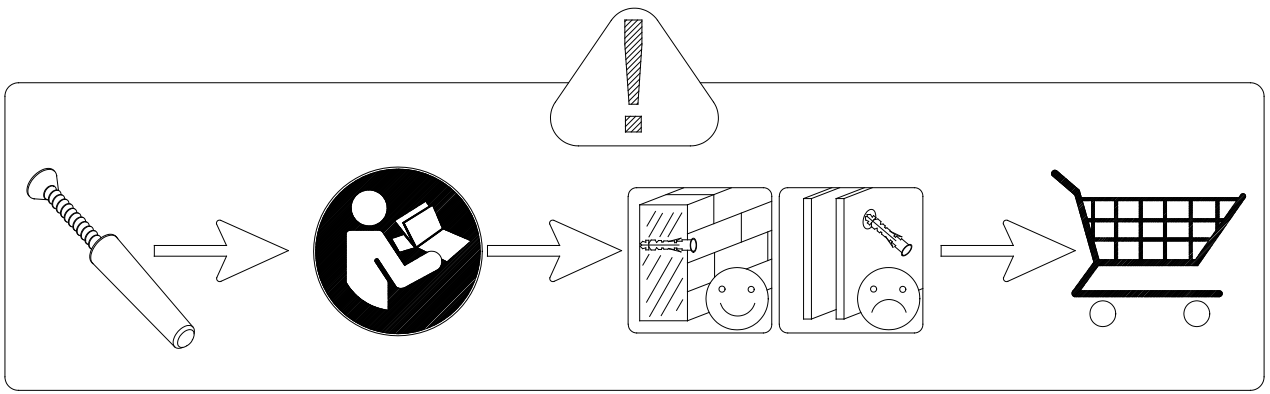
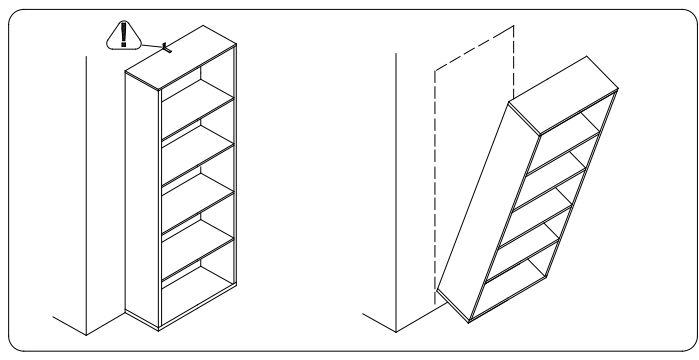



25

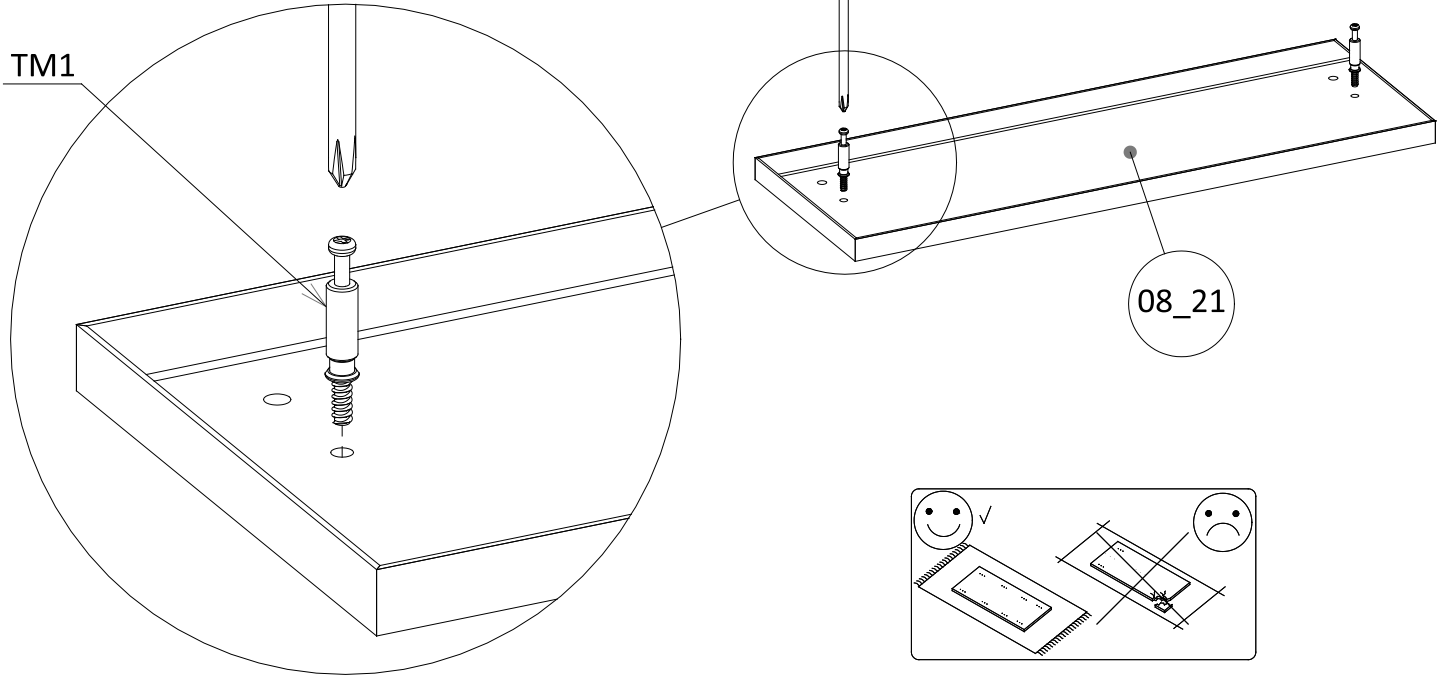
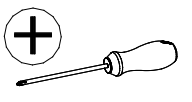
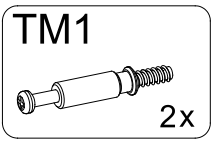

26

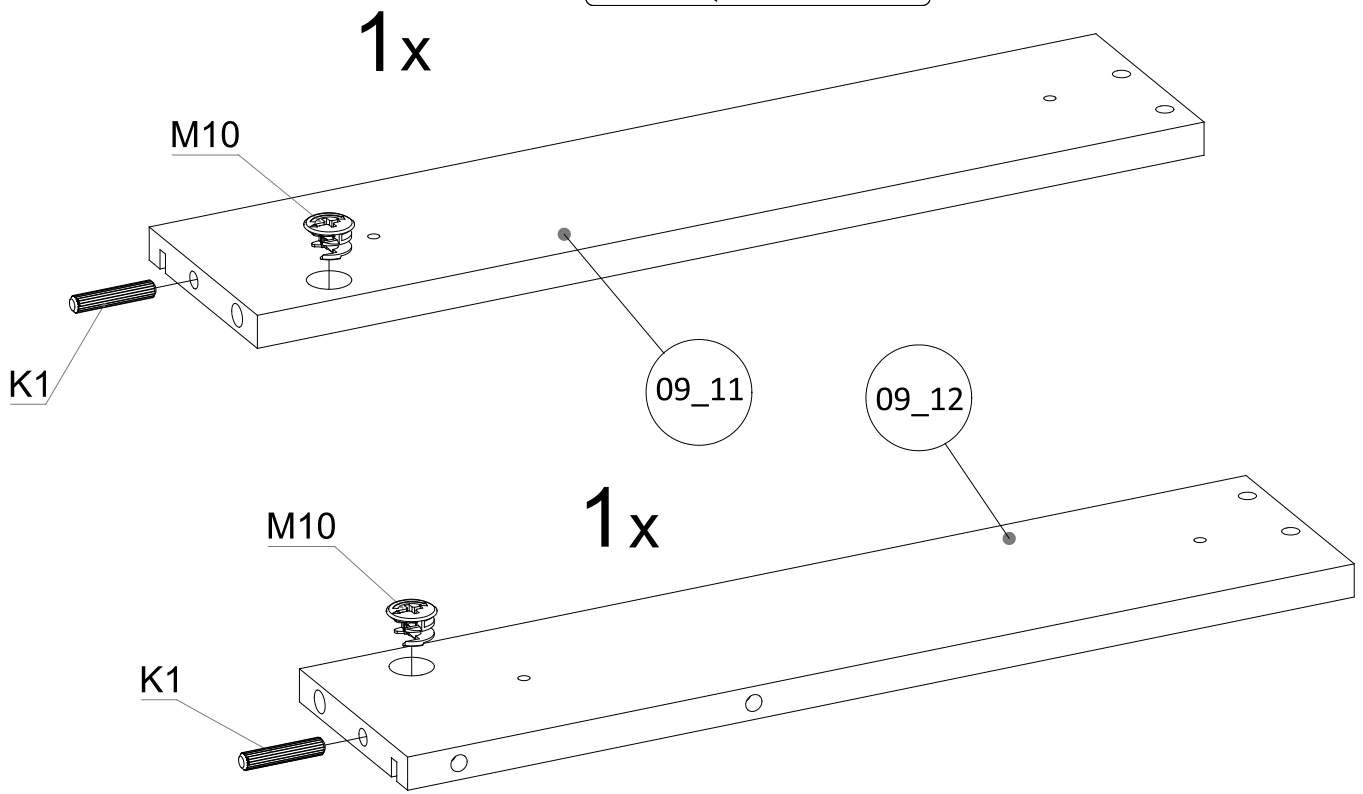
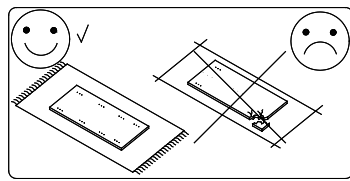
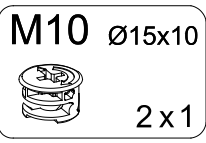
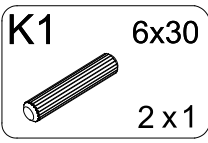

# 27

**KN1** 7x40  
4x1

**KL4**  
4 mm

1x

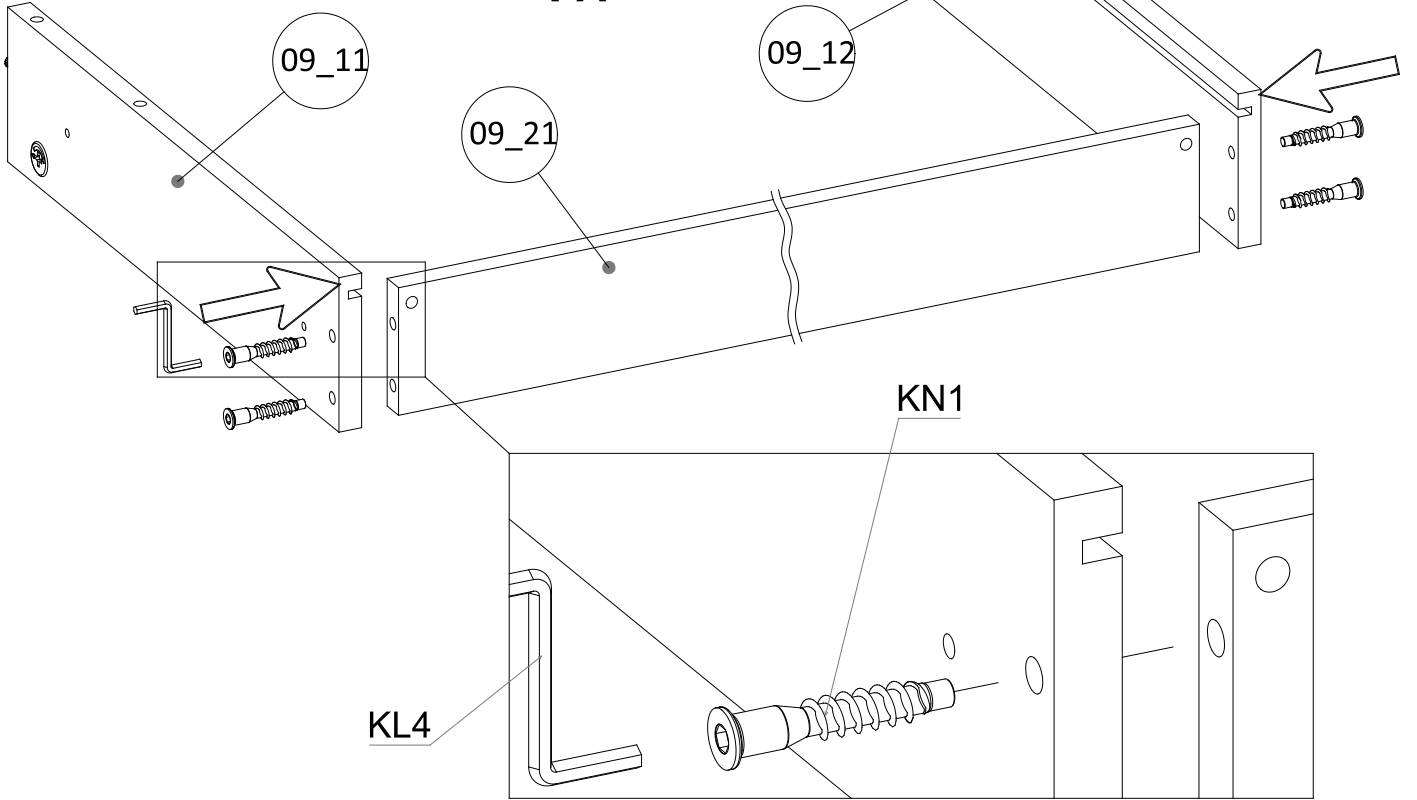

# 28

**ZS10** ø15  
K-02  
2x

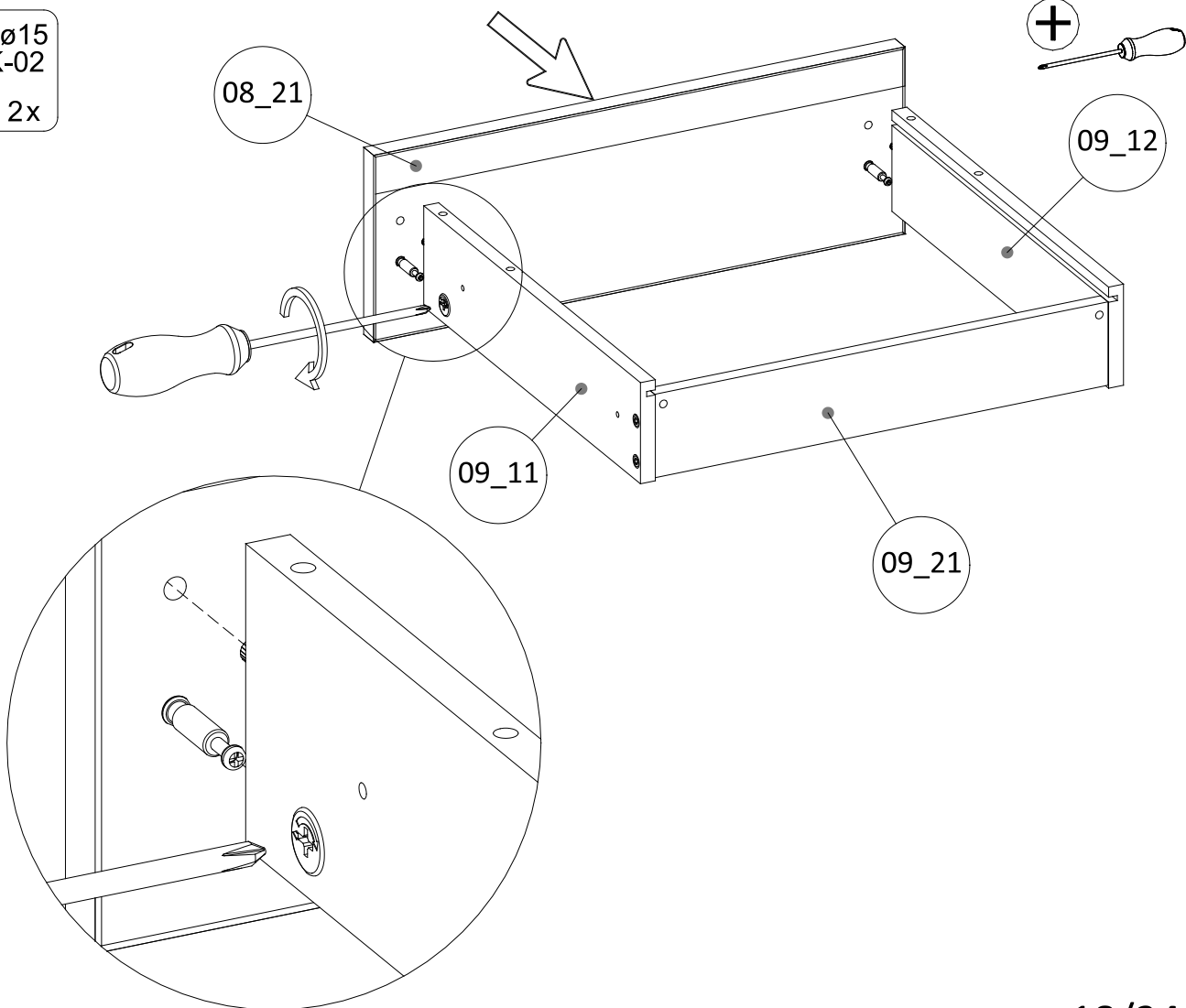

29

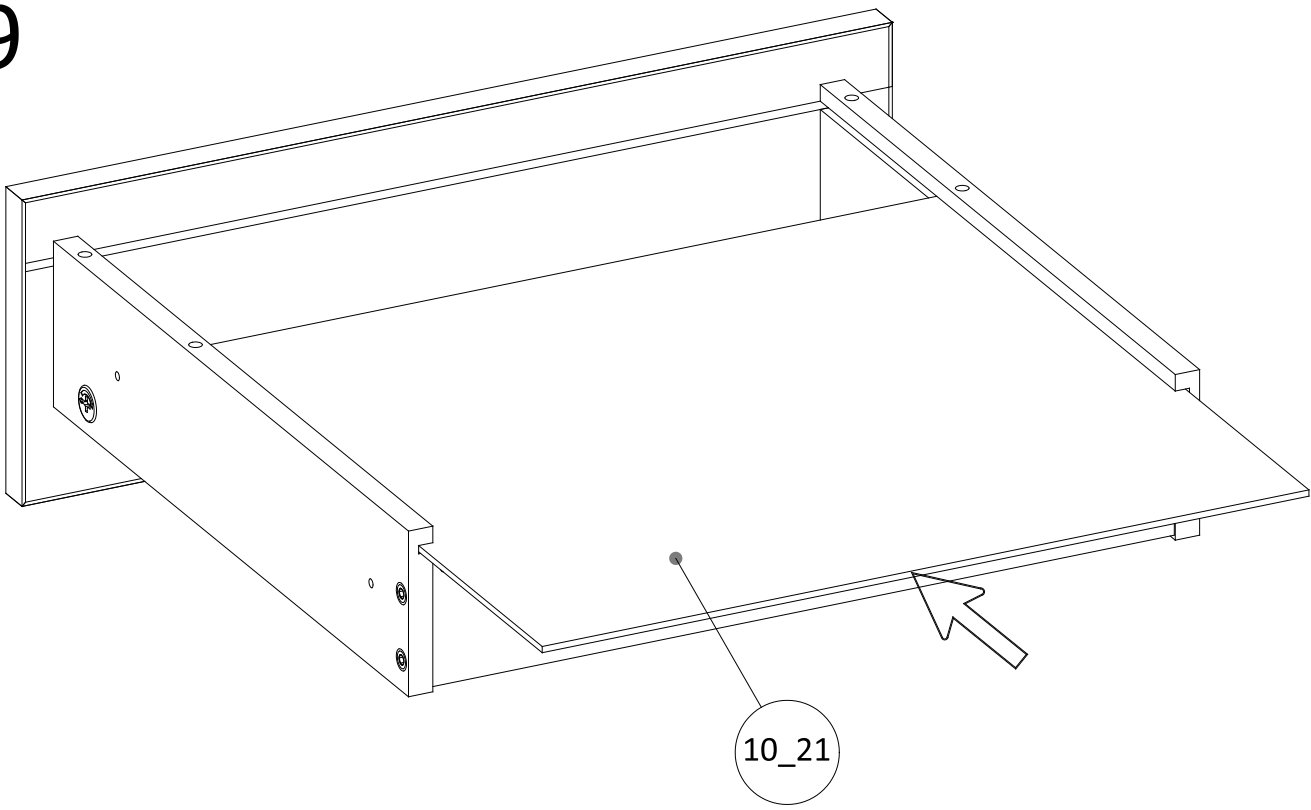

30

- G2 2,0x20 3x
- TK 1x

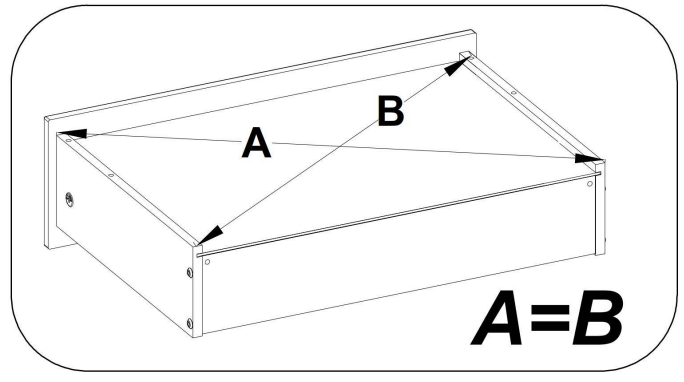
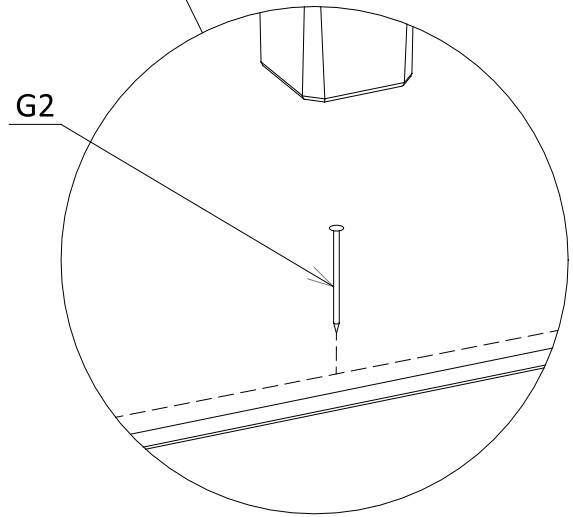
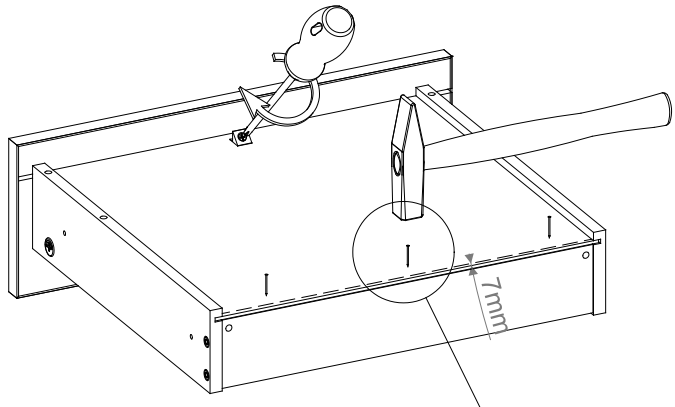
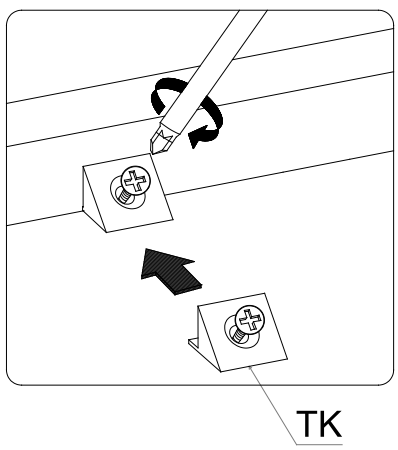
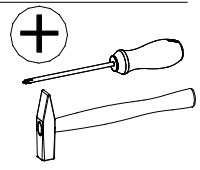

# 31

W3 3x13  
2x

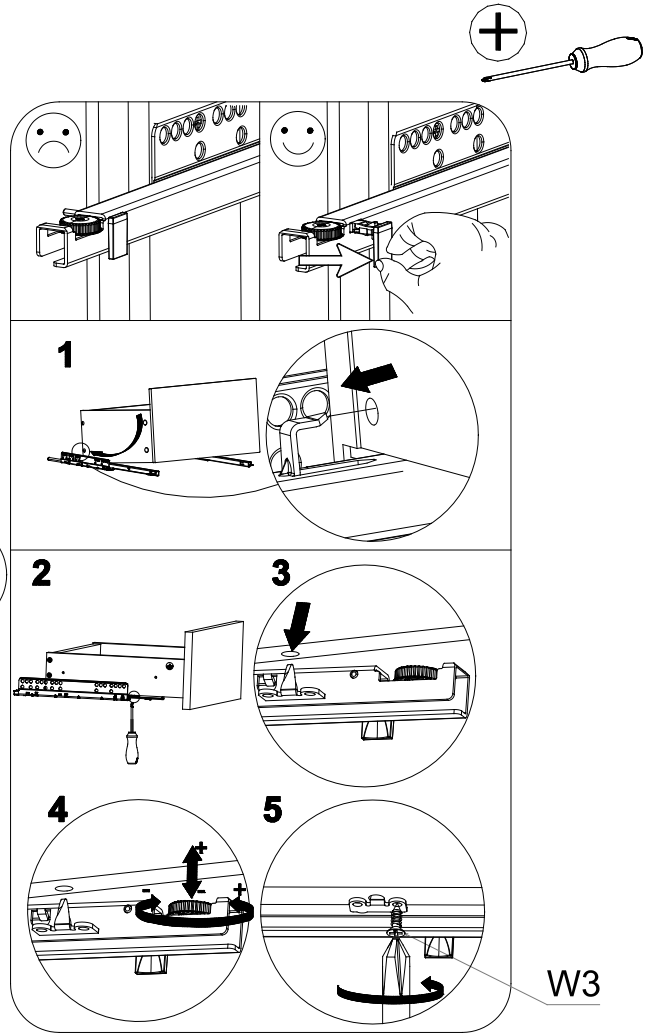
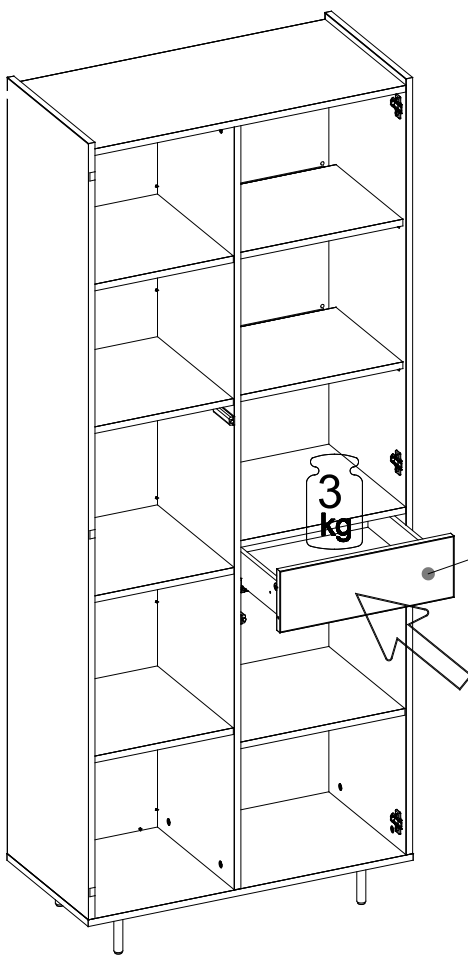

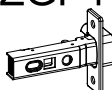

# 32

ZGP1 2x

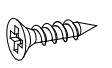
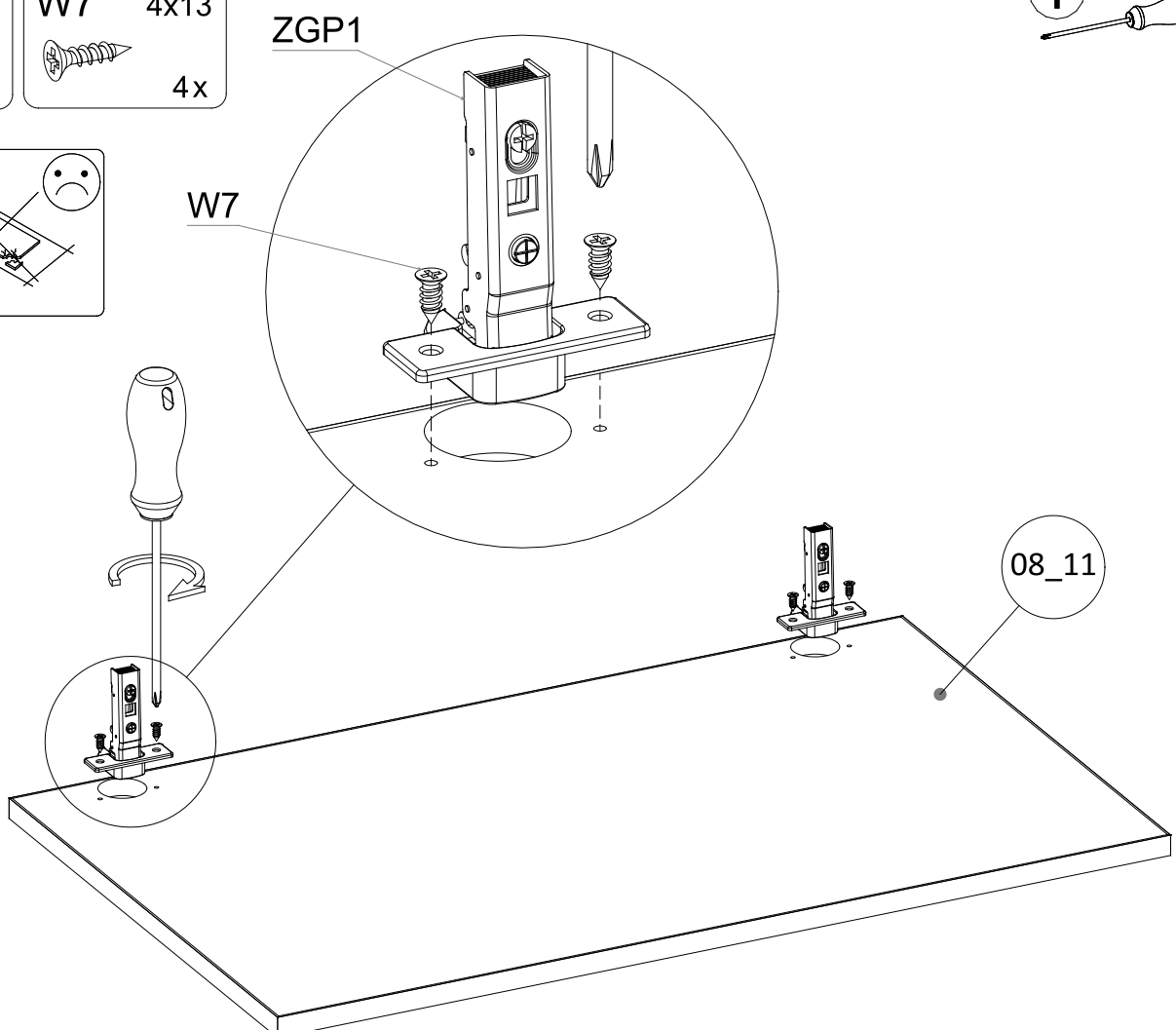
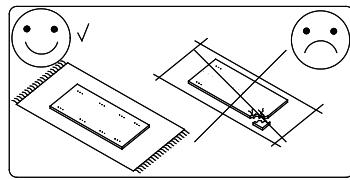
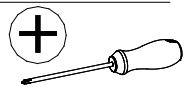

W7 4x13  
4x



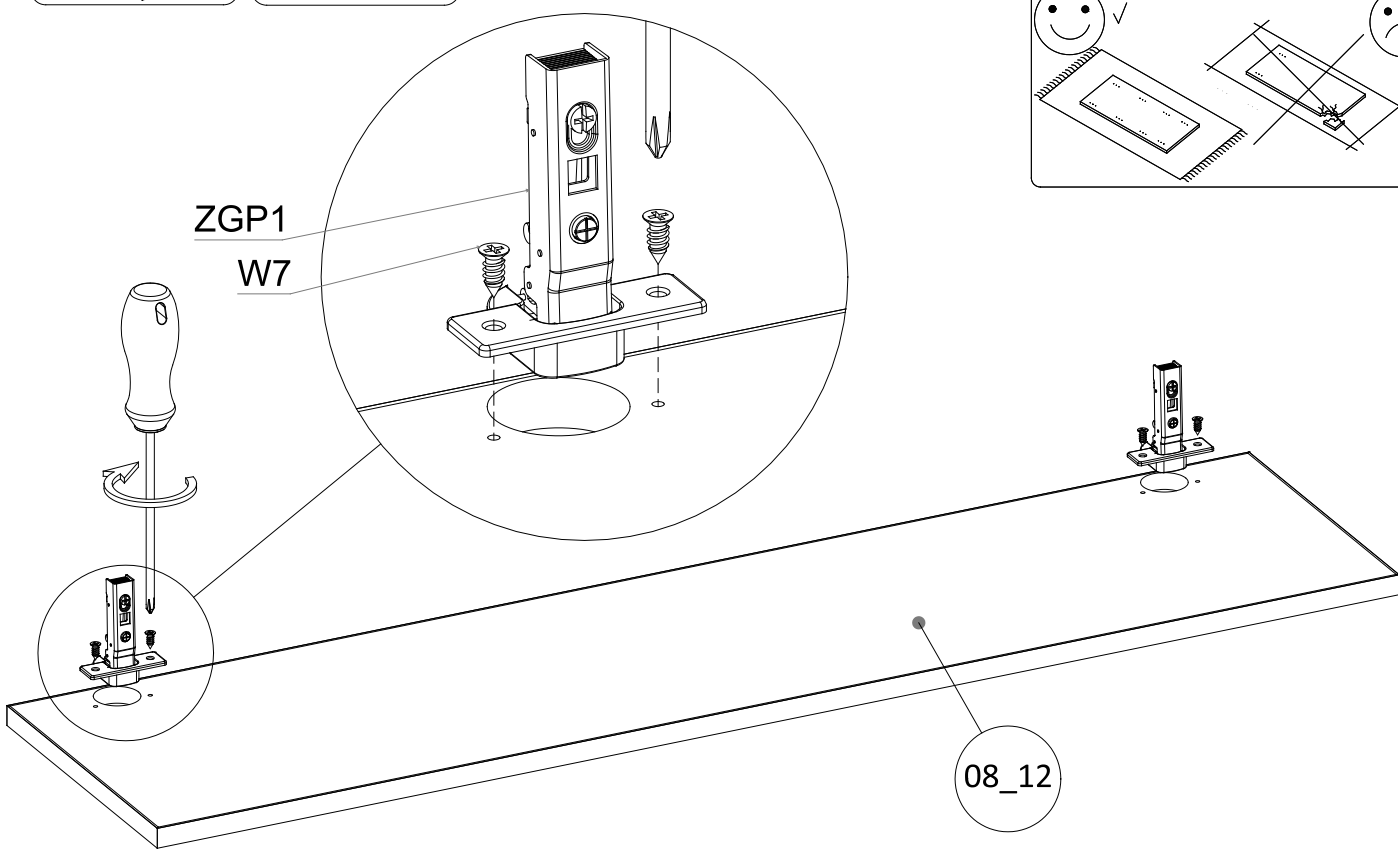
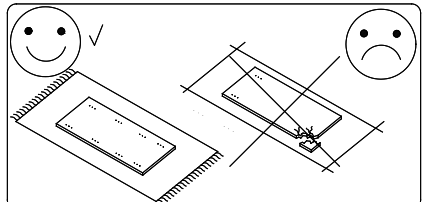
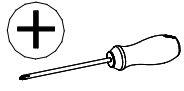
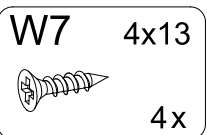
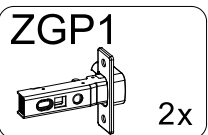

33

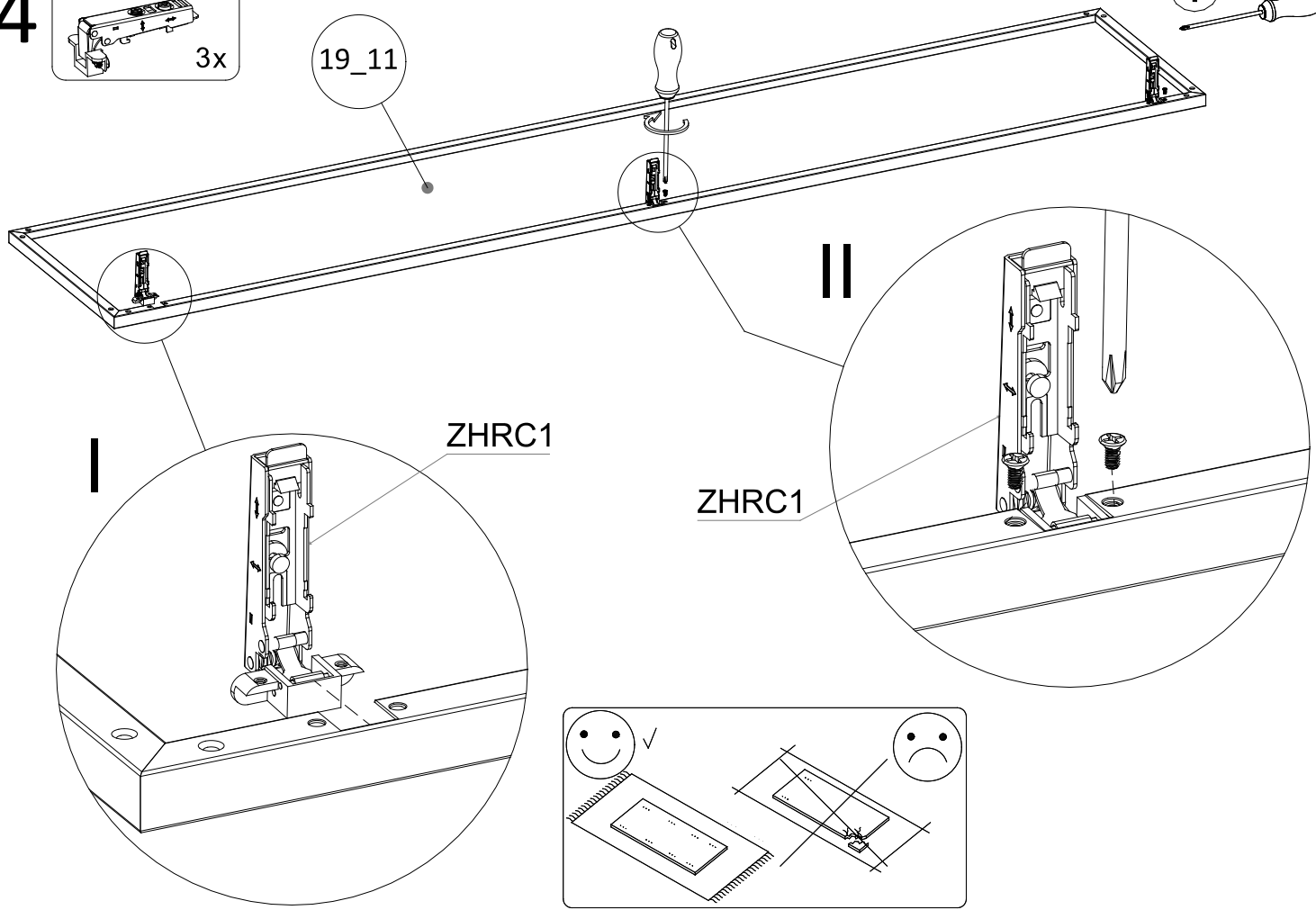
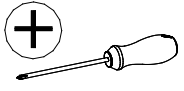
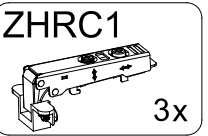

34

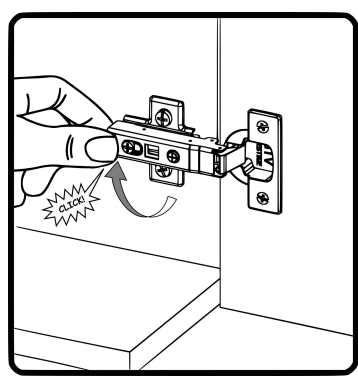
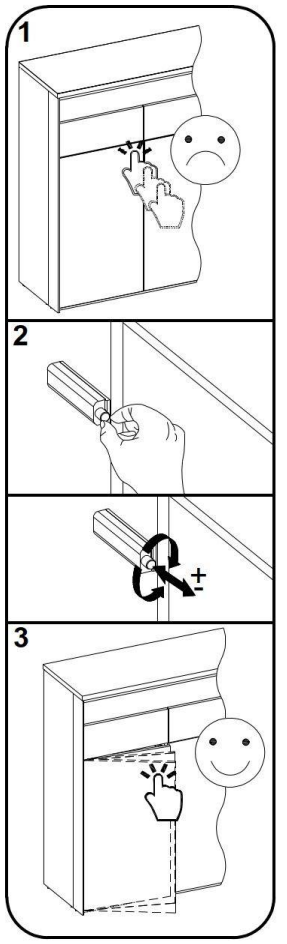
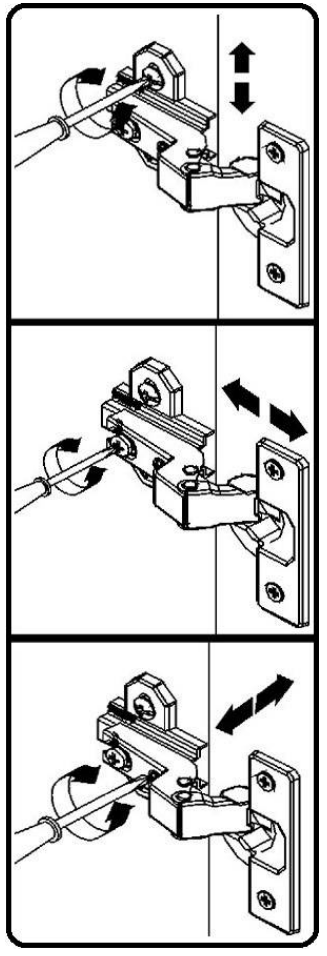
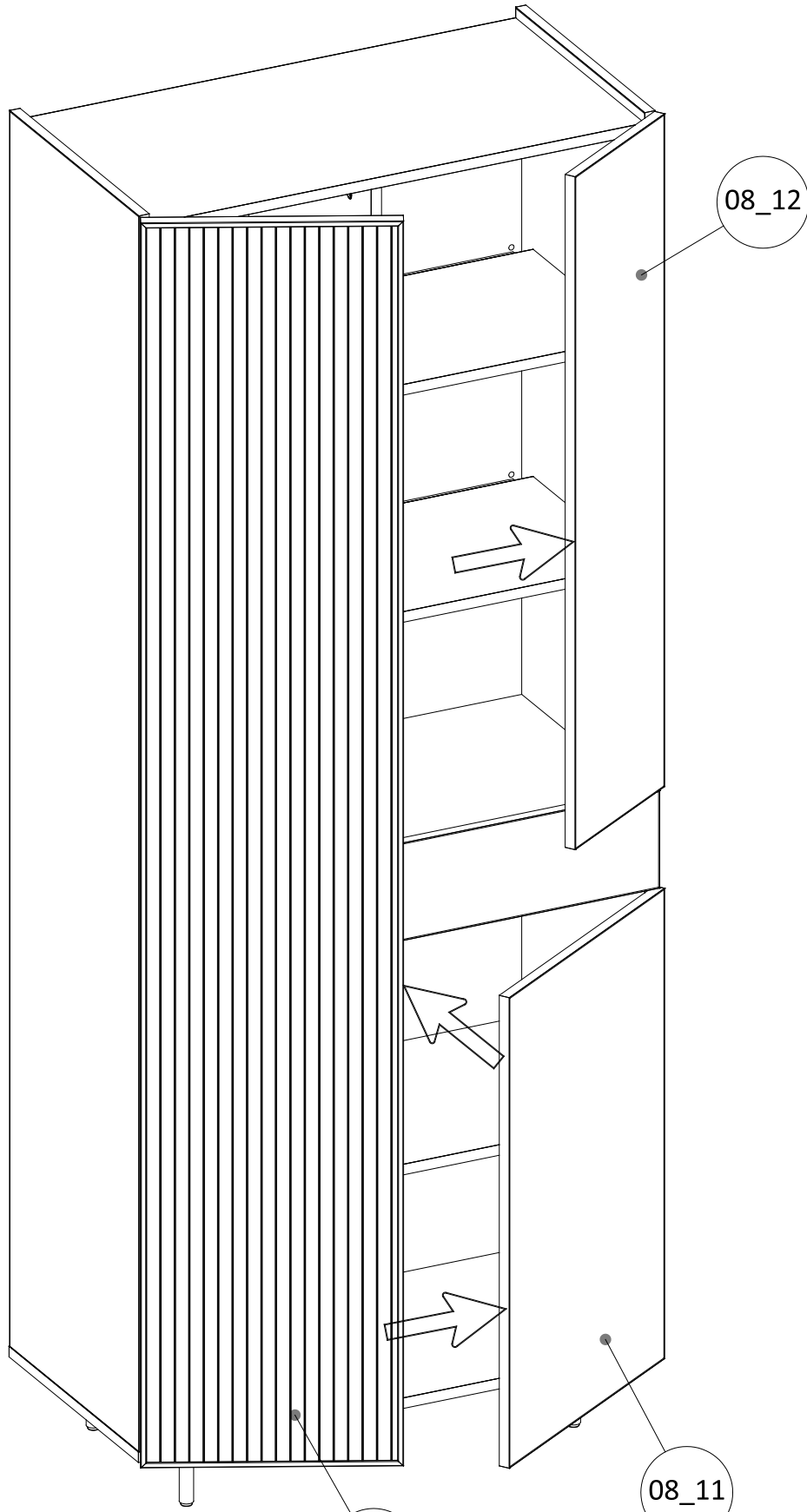
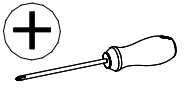



## **CZ**

### **Základy používání nábytku**

- 1.Nábytek by měl být používán k určenému účelu.
- 2.Nábytek by měl být používán v místnostech suchých, uzavřených a chráněných před škodlivými povětrnostními vlivy a před přímým slunečním zářením.
- 3.Nábytek by neměl být postaven na méně než půl metru před aktivními radiátory.
- 4.Nábytek musí být umístěn na rovném stabilním povrchu.
- 5.Montážní návod, počet součástí a příslušenství, které jsou nezbytné k montáži, najdete na informačním listu, který je přiložen k nábytku. Pokud byl na přání zákazníka dodán nábytek smontovaný, montážní návod není přiložen.
- 6.Na povrch nábytku nepokládejte vlhké předměty.
- 7.Po smontování nábytku seřídít (vyrovnat) dveře pomocí kolejničky.

### **Údržba a čištění:**

- 1.Povrchy z lamina a lakované čistit měkkým hadříkem.
- 2.K údržbě povrchu nepoužívejte žádné chemické látky ani hrubé hadříky.

Vážený zákazníku, v případě, že chybí některé části nebo jsou poškozené, označte je v montážních instrukcích a zašlete společně s reklamací. Pokud poškozená část bude napevno smontována, nebude se na ni vztahovat reklamace.

## **SK**

### **Základy používania nábytku:**

- 1.Nábytok by mal byť používaný na určený účel.
- 2.Nábytok by mal byť používaný v miestnostiach suchých, uzavretých a chránených pred škodlivými poveternostnými vplyvmi a pred priamym slnečným žiarením.
- 3.Nábytok by nemal byť postavený menej ako pol metra pred aktívnymi radiátormi.
- 4.Nábytok musí byť umiestnený na rovnom stabilnom povrchu.
5. Montážny návod, počet súčastí a príslušenstva, ktoré sú nevyhnutné na montáž, nájdete na informačnom liste, ktorý je priložený k nábytku. Pokiaľ bol na pranie zákazníka dodaný nábytok zmontovaný, montážny návod nie je priložený.
- 6.Na povrch nábytku nekladte vlhké predmety.
- 7.Po zmontovaní nábytku nastaviť (vyrovnať) dvere pomocou kolajničky.

### **Údržba a čistenie:**

- 1.Povrchy z lamina a lakované čistit mäkkou handričkou.
  - 2.Na údržbu povrchu nepoužívajte žiadne chemické látky ani hrubé handričky.
- Vážený zákazník, v prípade, že chýbajú niektoré časti alebo sú poškodené, označte ich v montážnych inštrukciách a zašlite spoločne s reklamáciou. Pokiaľ poškodená časť bude napevno zmontovaná, nebude sa na ňu vzťahovať reklamácia.