

Montageanweisung / Installation instructions / Instruction de montage / Istruzioni di montaggio  
montagehandleiding / Instrukcja montażu / Montaj talimatlar / Osszeszerelési útmutató / Nàvod k montáži /  
Nàvod na montáž / Instrucțiune de montaj / Инструкция по монтажу / Montaj talimatina / Monteringsanvisningar  
Upute za montažu / Instrucciones de Montaje / Navodila za montažo

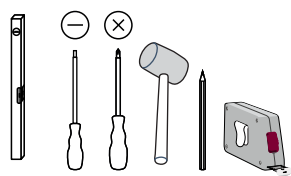

## DAMA MIRO PRISMA RIO VITTORIA

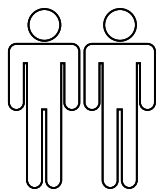
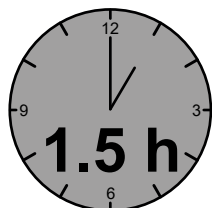
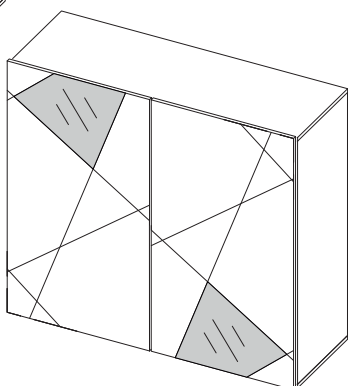
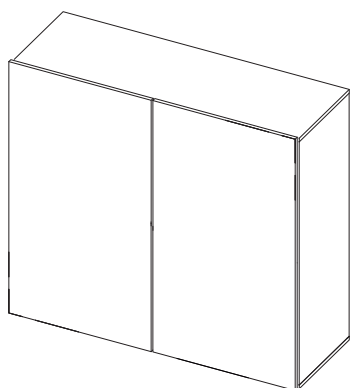
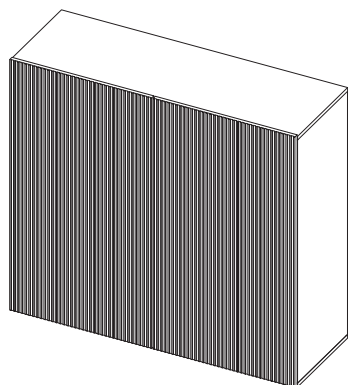
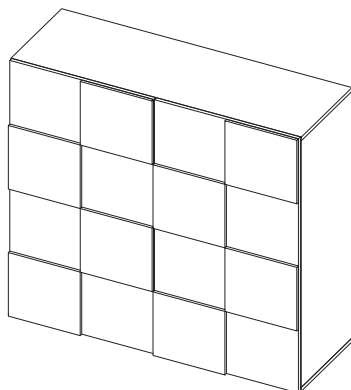

LC S.p.A  
Via del Piano s.n  
61030 Isola del Piano  
(PU) Italia  
<http://www.lcmobili.com>

**Pt** – leia atentamente as instruções de montagem, uma vez que não assumimos qualquer responsabilidade por defeitos resultantes de uma montagem incorrecta.

**D** – bitte lesen sie diese montageanleitung gut durch, Da wir für fehler, die durch falsche montage entstehen, Keine haftung übernehmen!

**Gb** – please read these installation instructions Through carefully as we cannot accept any liability For faults occurring as a result of incorrect installation!

**Cz** – přečtěte si prosím pozorně tento návod k montáži, Aby jste předešli chybám vzniklých špatnou montáží, Za které neručíme!

**F** – veuillez lire attentivement cette notice de montage, Car nous déclinons toute responsabilité en cas d'erreurs Découlant d'un montage erroné !

**I** – prego leggere attentamente le istruzioni per il montaggio, Poiché decliniamo qualsiasi responsabilità Per difetti derivanti da montaggio errato.

**S** - läs monteringsanvisningarna noggrant. Vi avsäger oss allt ansvar för defekter som Uppstår p.g.a. Felaktig montering.

**Hr** – pažljivo pročitajte upute za montažu, Jer otklanjamo svaku odgovornost za pogreške Nastale uslijed pogrešne montaže.

**Slo** – prosimo, da pozorno preberete navodila za montažo, Saj zavračamo vsakršno odgovornost za napake, Ki bi nastale zaradi napačne montaže.

**Nl** – leest u alstublieft deze montagehandleiding goed door, Voor fouten door verkeerde montage zijn wij niet verantwoordelijk.

**Pl** – prosze uwaznie zapoznac sie z instrukcja montazu, Poniewaz nie ponosimy odpowiedzialnosci za niewlasciwy montaz.

**HU** – Kérjük, olvassa el figyelmesen ezt az összeszerelési útmutatót, mert a helytelen összeszerelésből a dódó hibákért nem vállalunk felelősséget!

**SK** – Prosime, dobre prečítajte si tento návod na montáž, pretože nepreberáme žiadne ručenie za chyby, ktoré vzniknú na základe chybnej montáže!

**RO** – Vă rugăm să cititi cu atenție aceste instrucțiuni de montaj deoarece nu preluăm garanția pentru defecte ce apar datorită unui montaj incorect!

**RUS** – Пожалуйста, внимательно ознакомьтесь ù с данной инструкцией по монтажу, поскольку мы не несем ответственности за ошибки, причиной которых является неправильный монтаж.

**TU** – Ilkonce kullanma klavuzunu iyi okkuyun, yalnıs montaj yapasanız bunun sorumlusu biz degiliz.

**ES** – Se ruega leer con atención las instrucciones de montaje debido a que declinamos cualquier responsabilidad por defectos derivados de un montaje erróneo.

**DAMA  
MIRO  
PRISMA  
VITTORIA  
RIO**



**04FS**

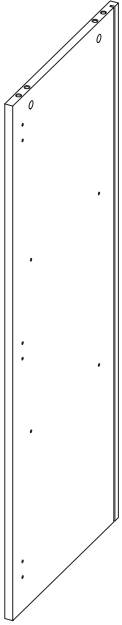

**04CI**

**04TR**



**04PI**



**04PI**

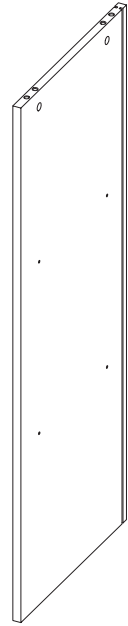

**04PI**



**04PI**

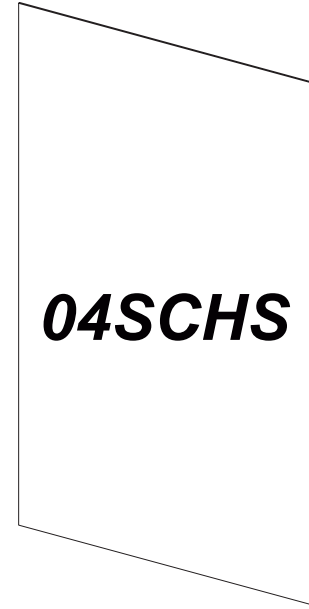

**04SCHS**

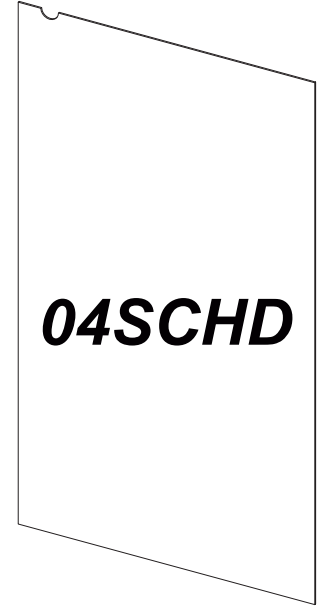

**04SCHD**



**04FO**

**04FD**

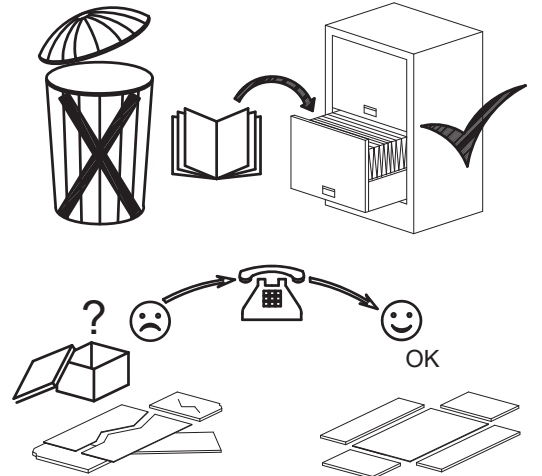

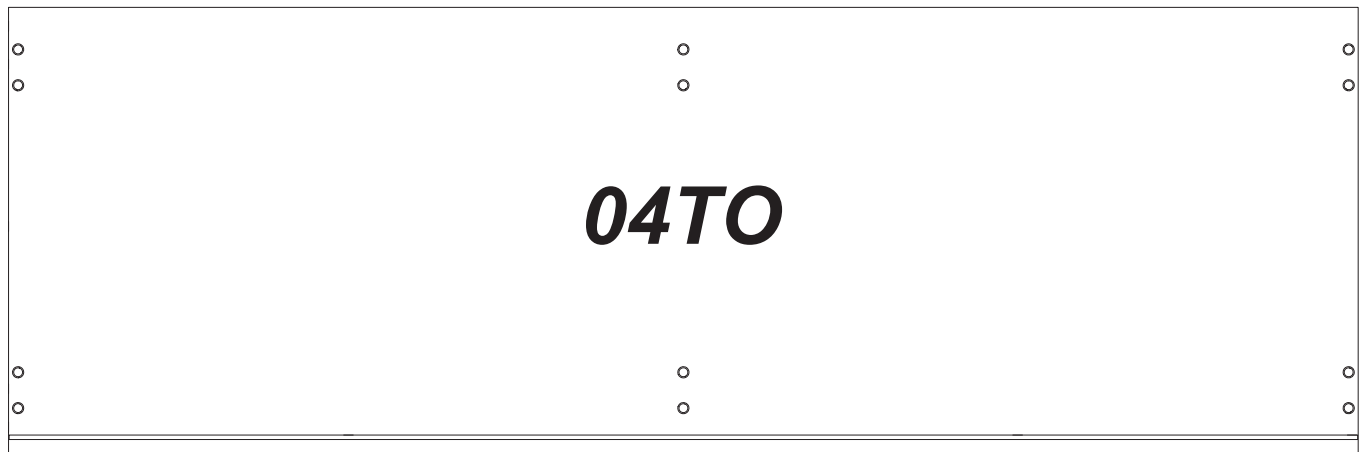

**Vrchní deska**  
**Horná deska**

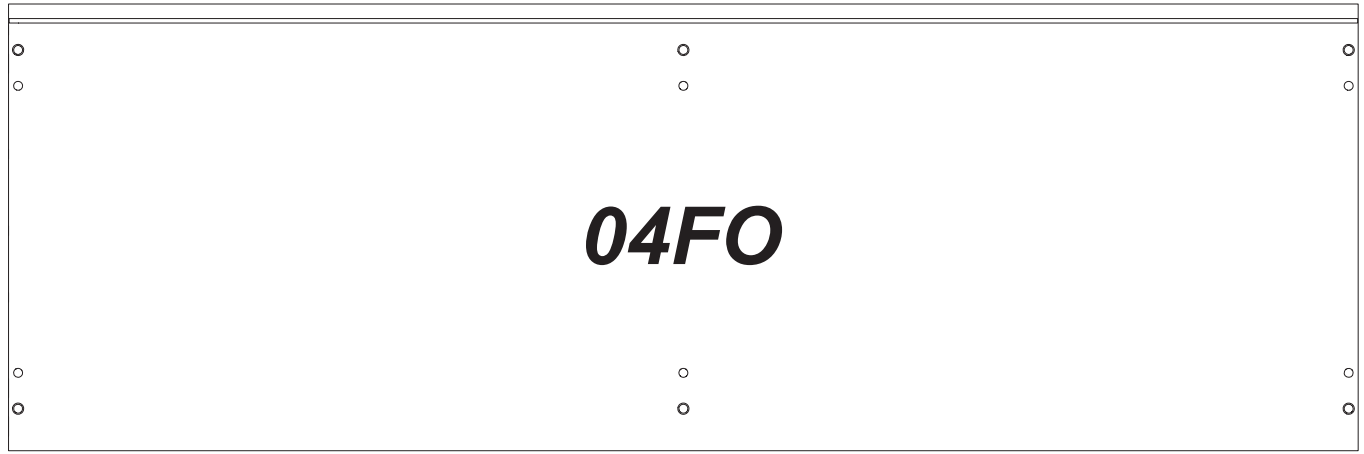
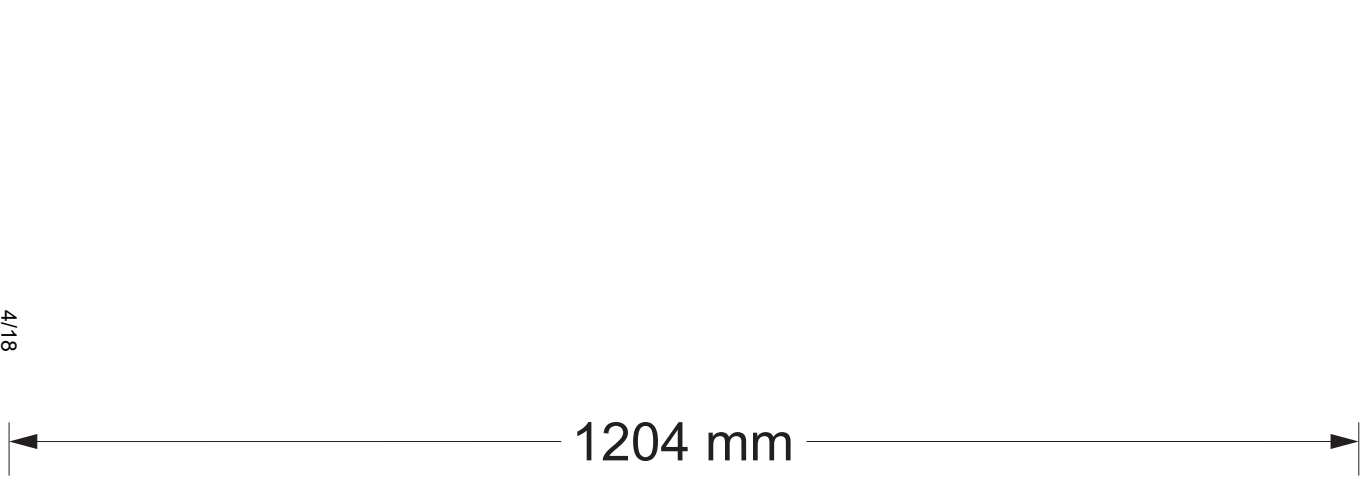
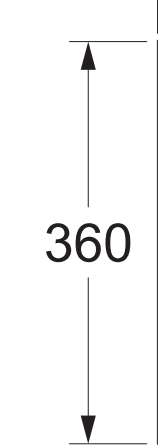
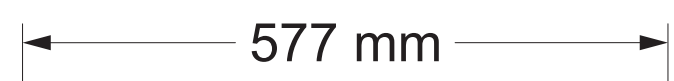

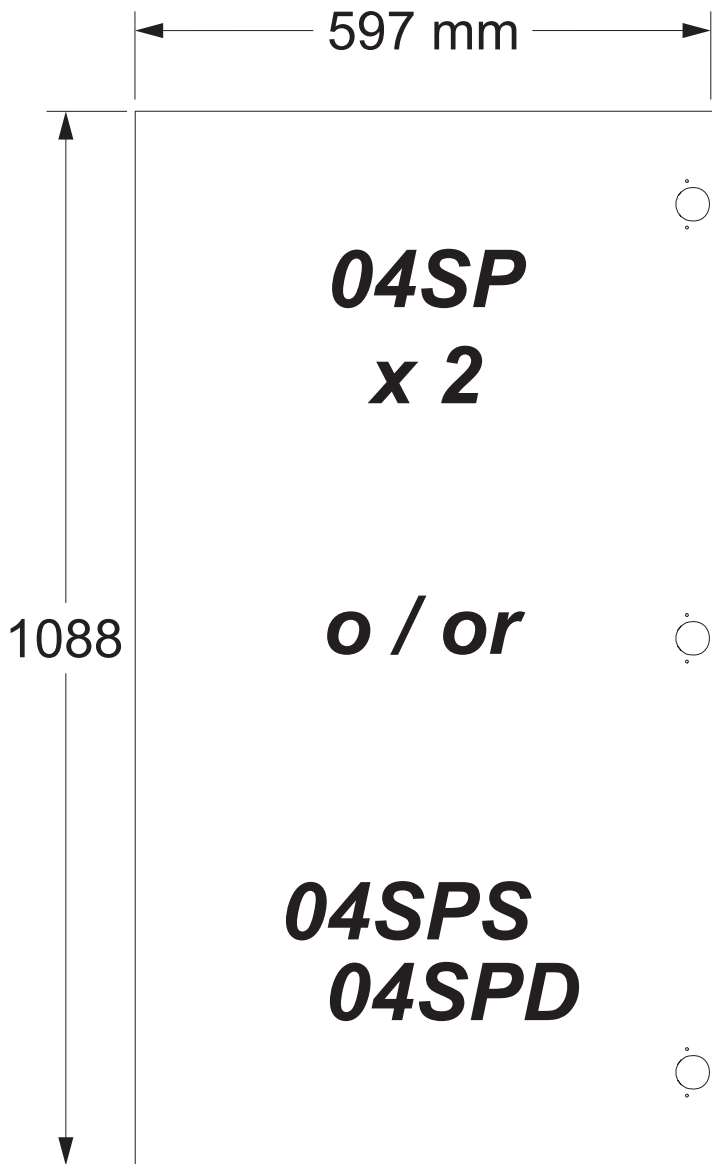

***elní strana***  
***Predná strana***

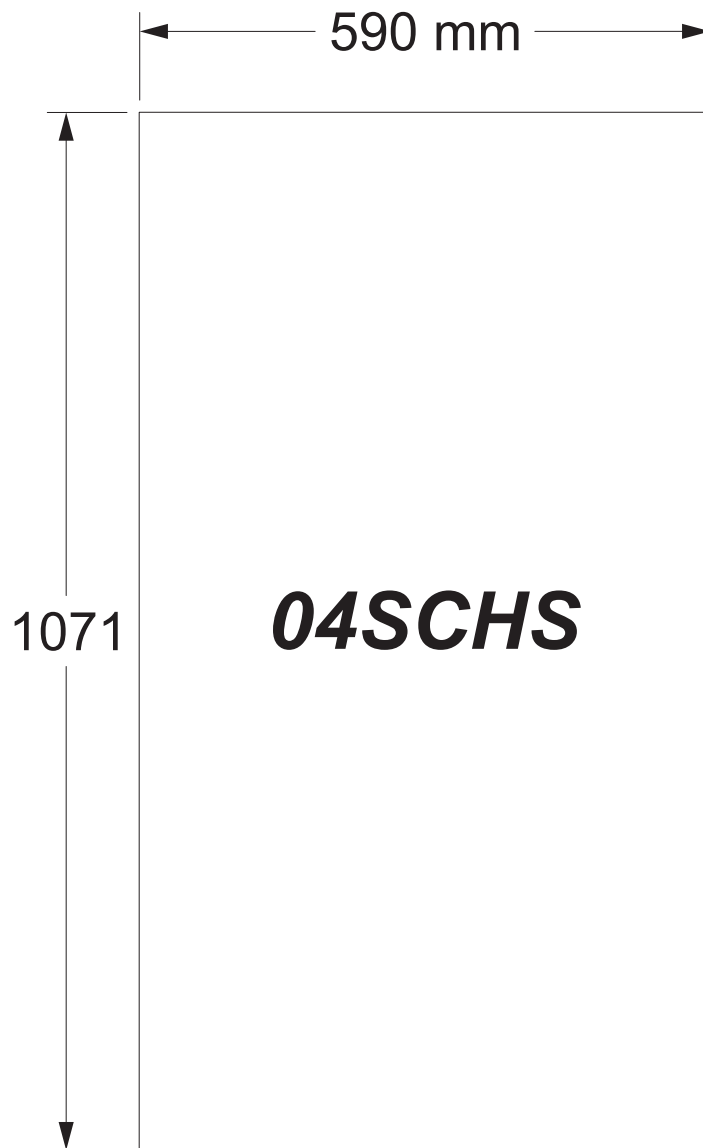

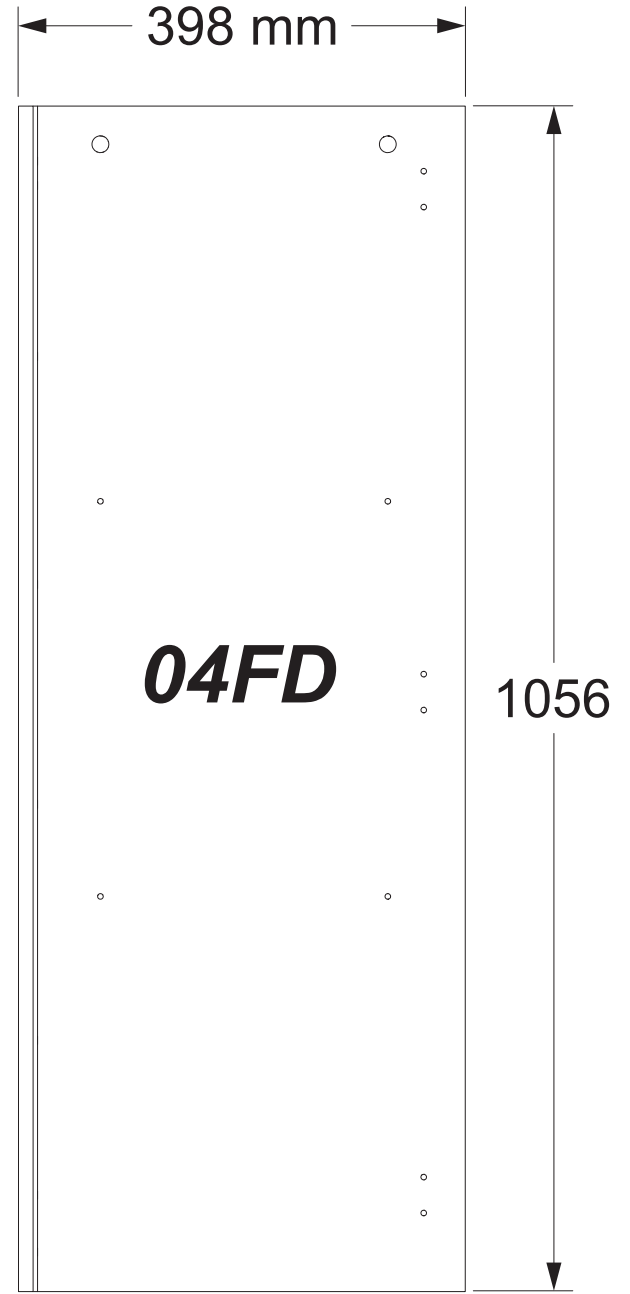
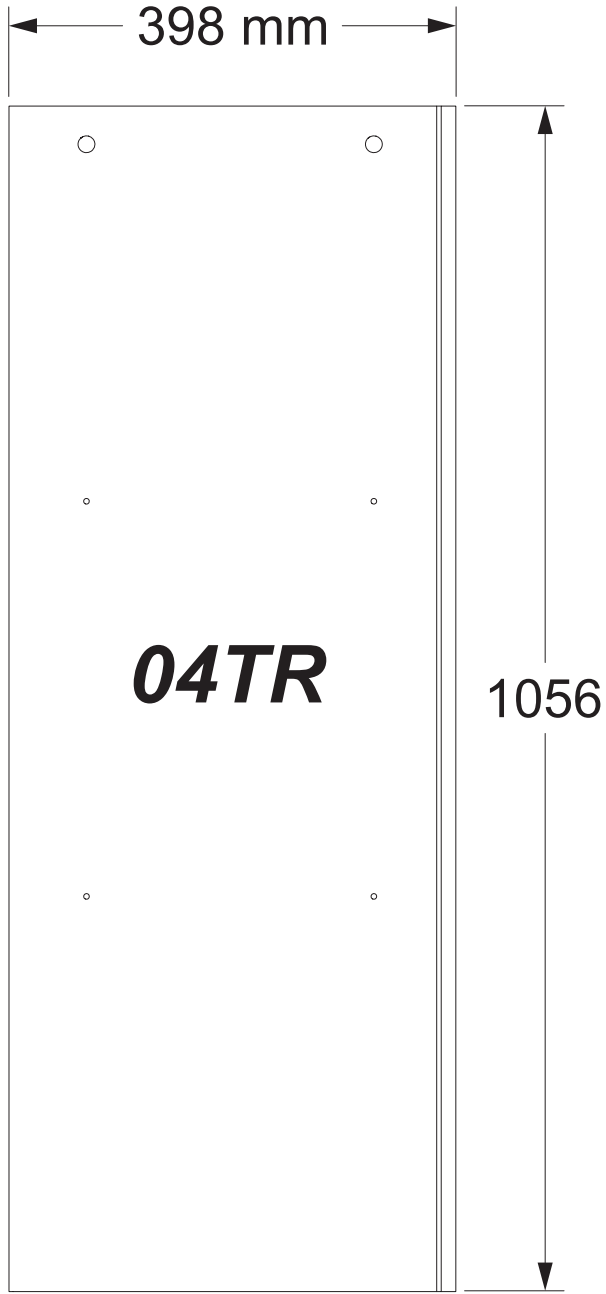
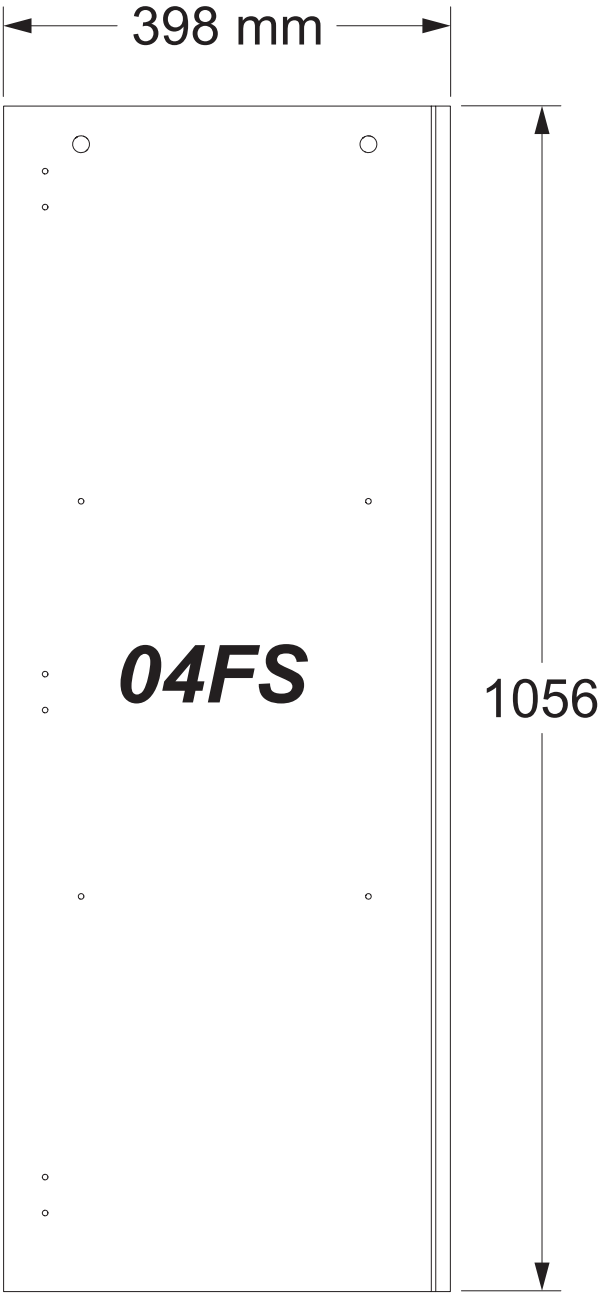

**DAMA**

**04SP x 2**

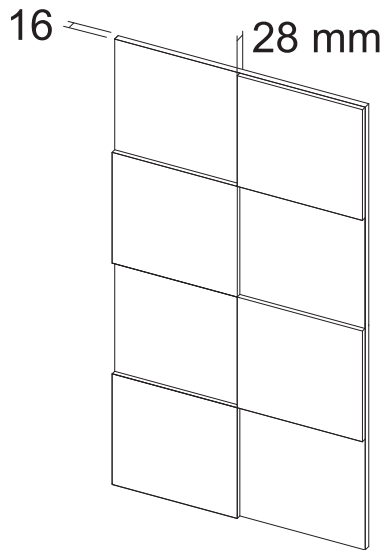
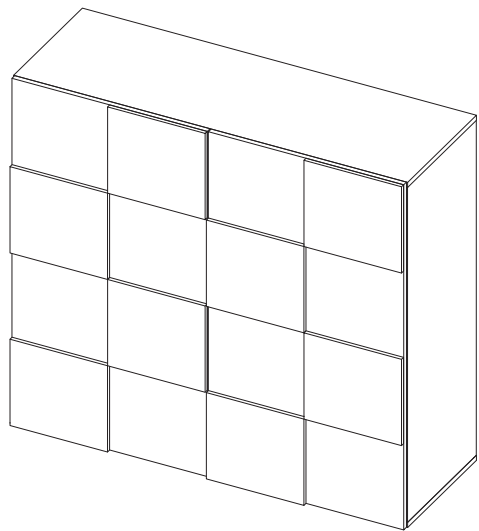

**RIO**

**04SP x 2**

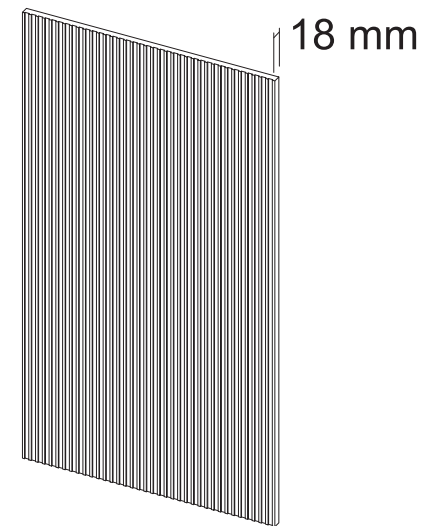
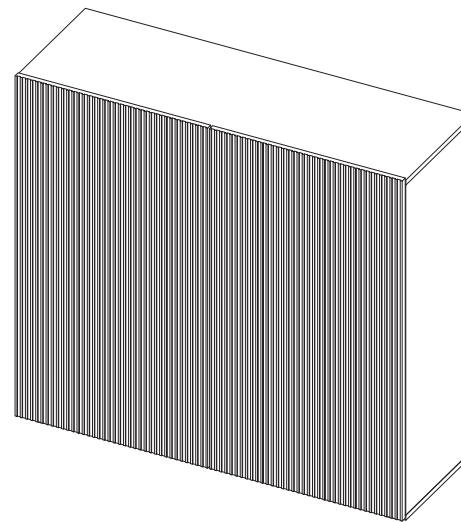

**MIRO/PRISMA**

**04SP x 2**

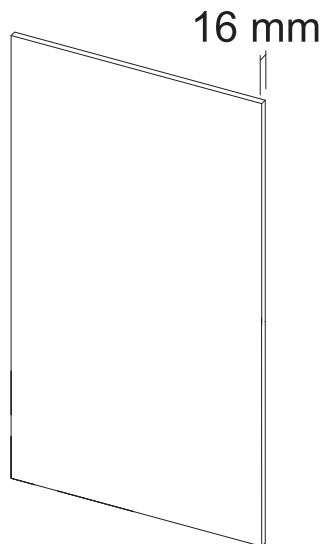
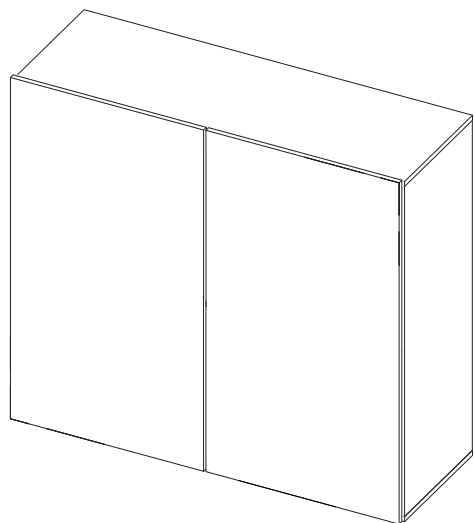

**VITTORIA**

**04SP x 2**

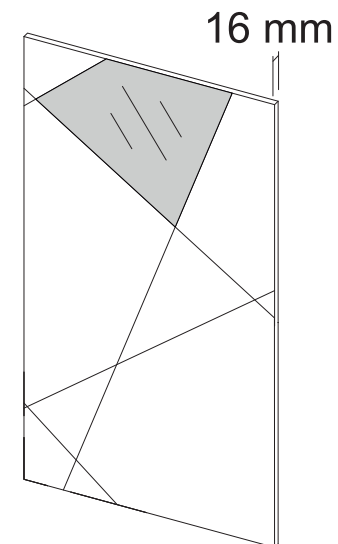
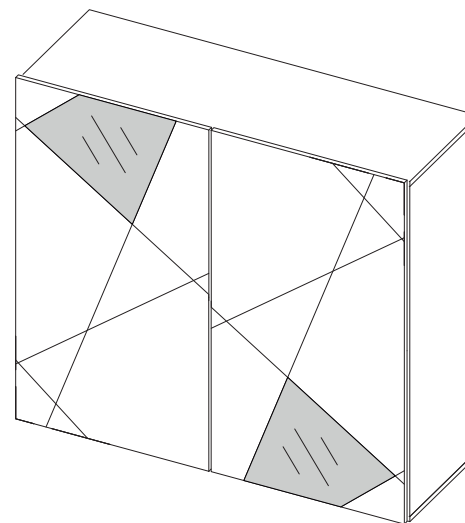

# DAMA

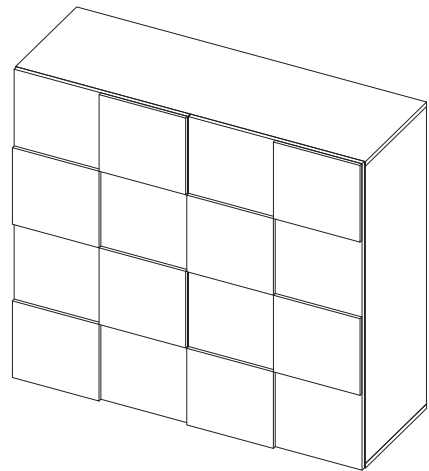

04SPS

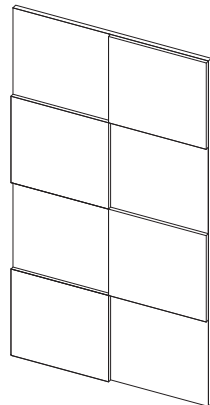

04SPD

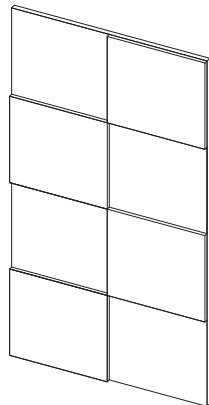

# RIO

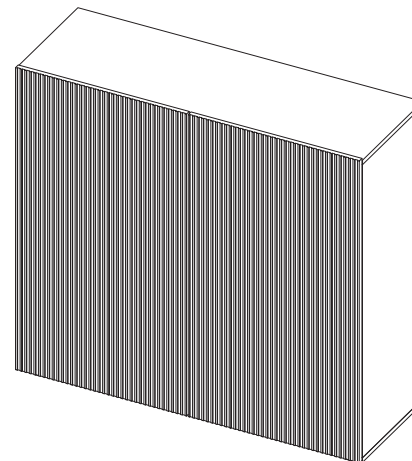

04SPS

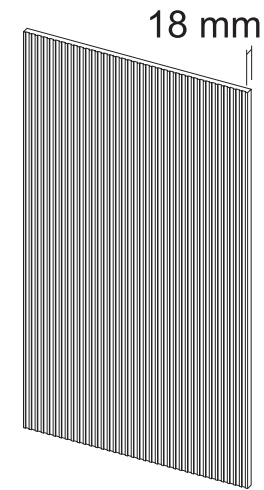

04SPD

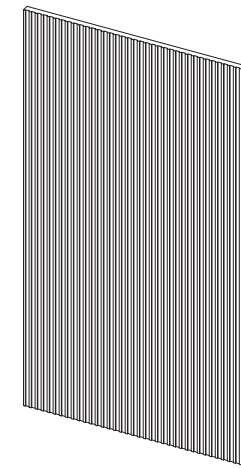

# MIRO/PRISMA

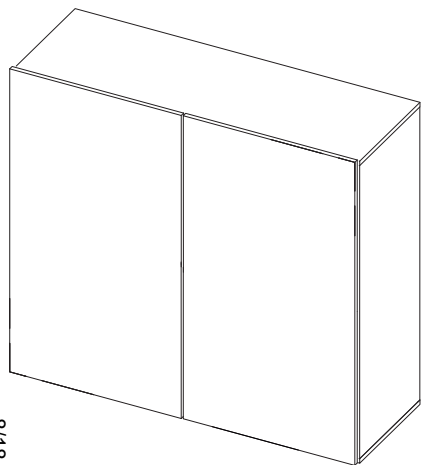

04SPS

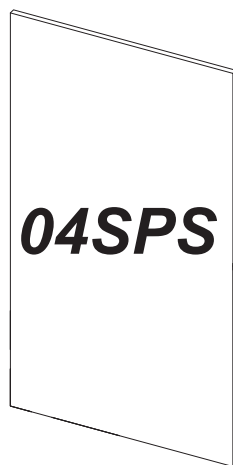

04SPD

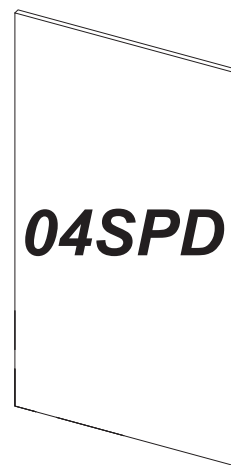

# VITTORIA

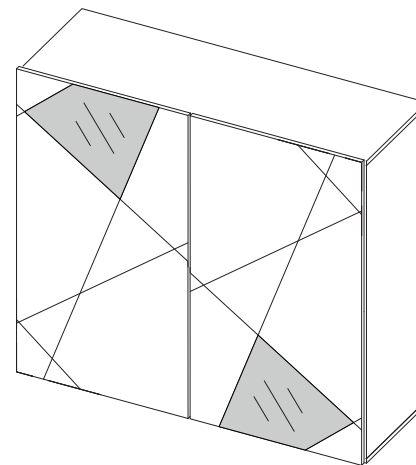

04SPS

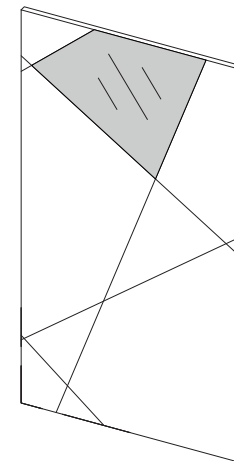

04SPD

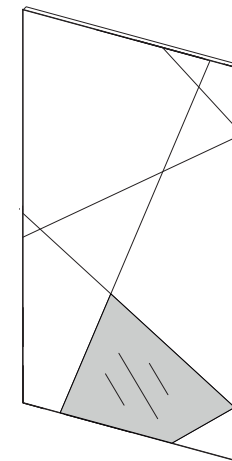

# RIO

## Ochranný obal

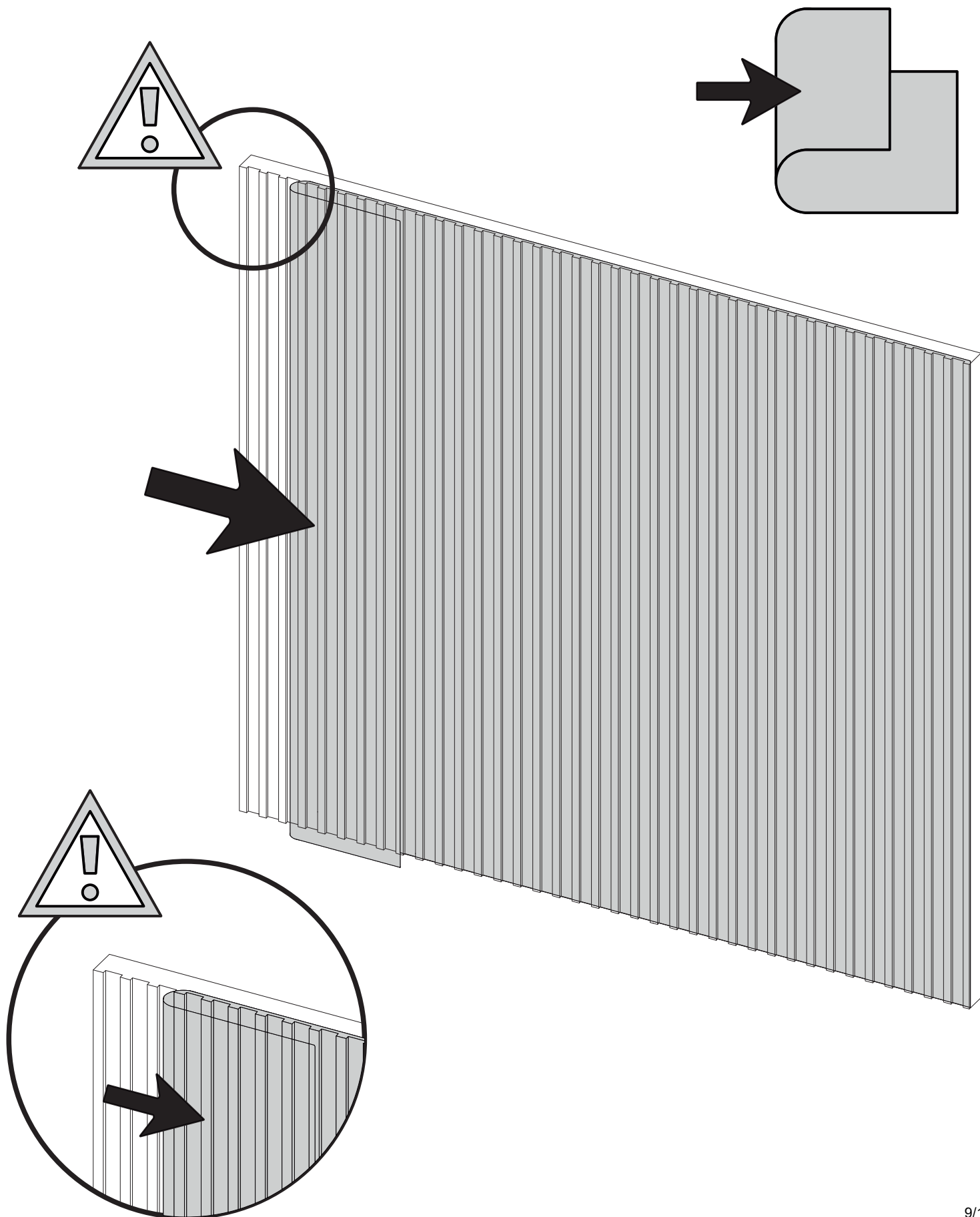

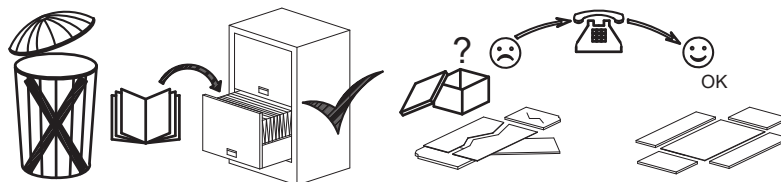

**H2E**

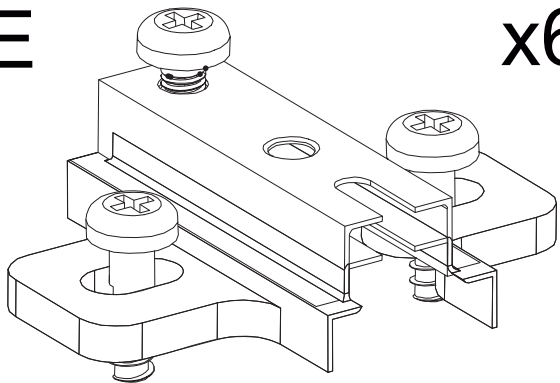

**x6**

**C0 x6**

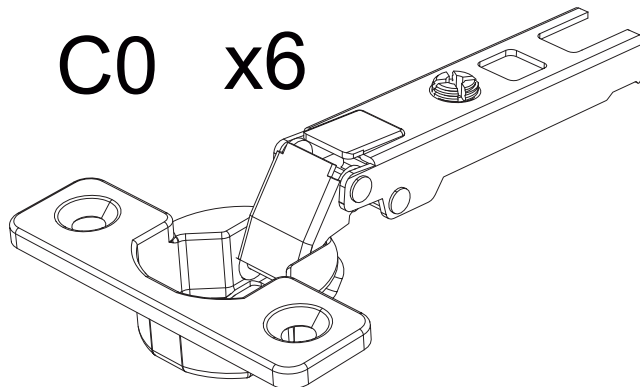

**V415**

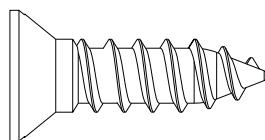

**x12**

$\varnothing 4 \times 15$  mm

**P**

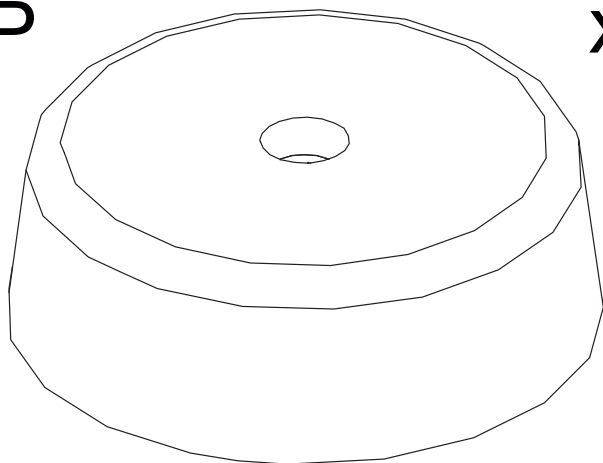

**x5**

**V4530**

**x5**

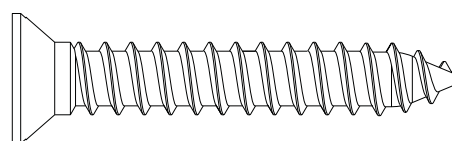

$\varnothing 4.5 \times 30$  mm

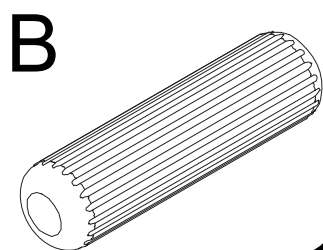
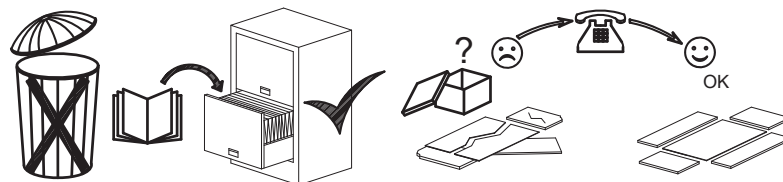

x12

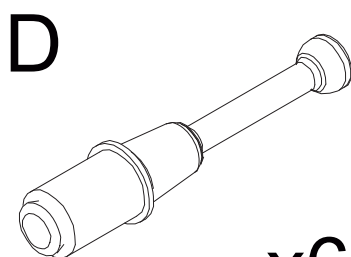

x6

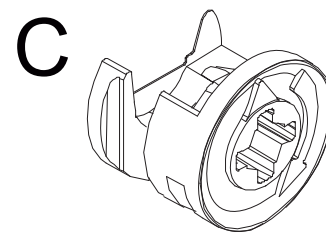

ø15

x6

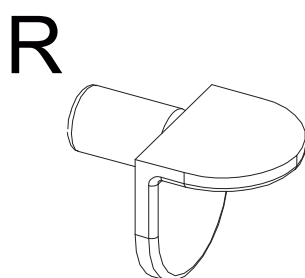

x16

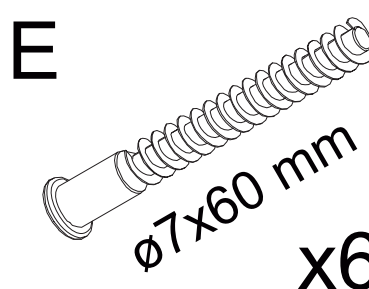

ø7x60 mm

x6

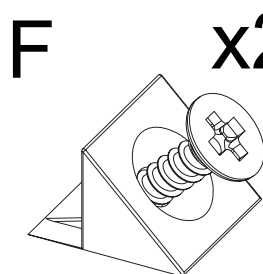

x20

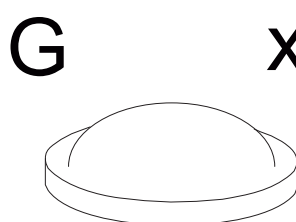

G

x4

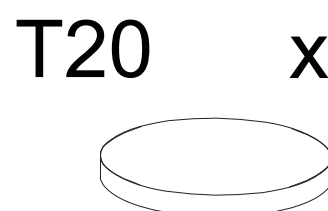

T20

x6

V418 x2

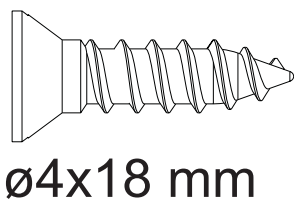

ø4x18 mm

PST x1

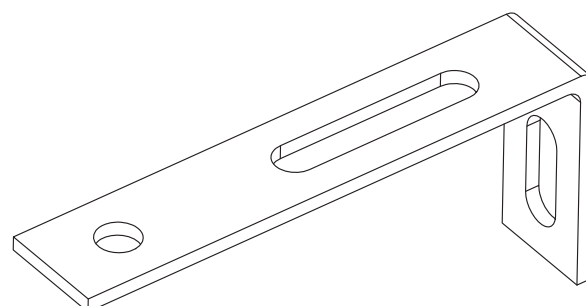

1

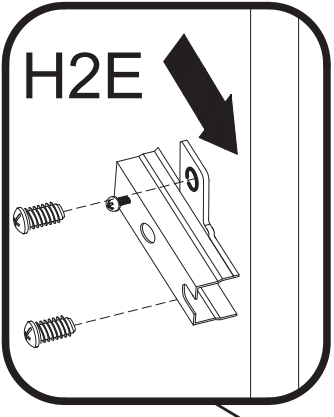
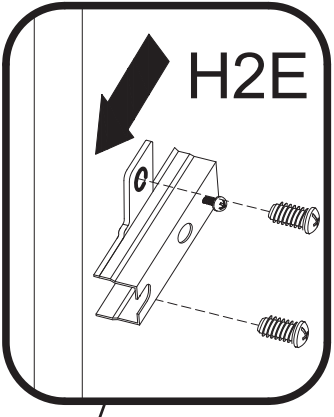

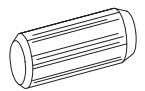
**B**  x12  
8x30 mm.

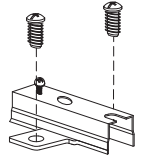
**H2E**  x6

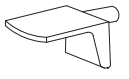
**R**  x16

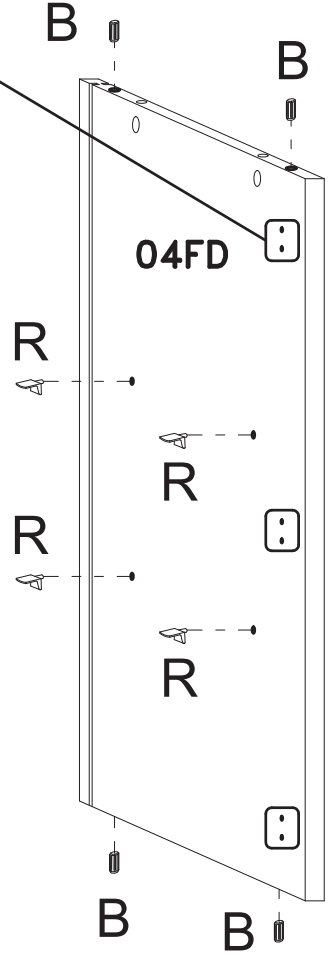
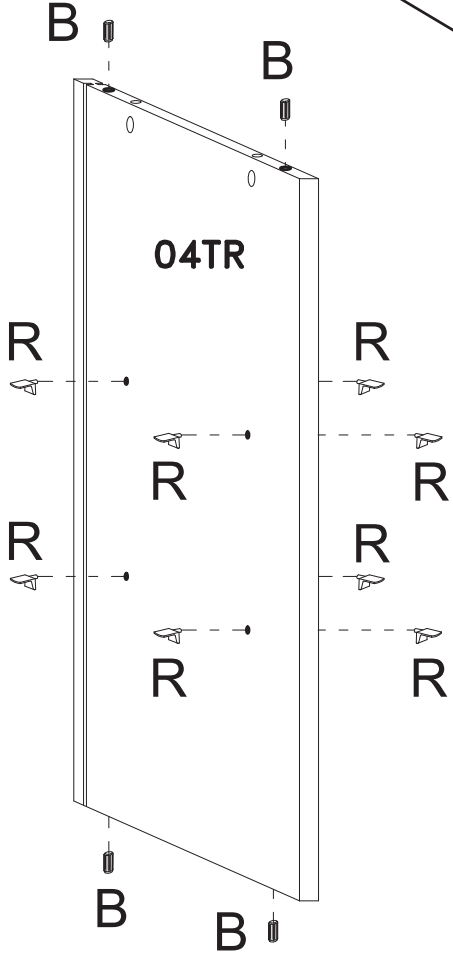
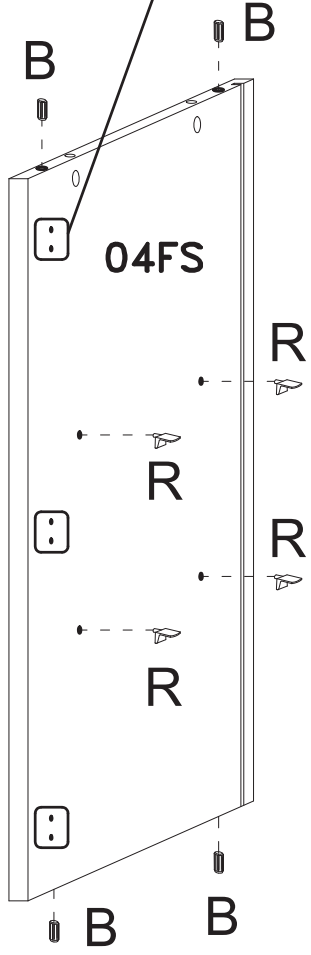

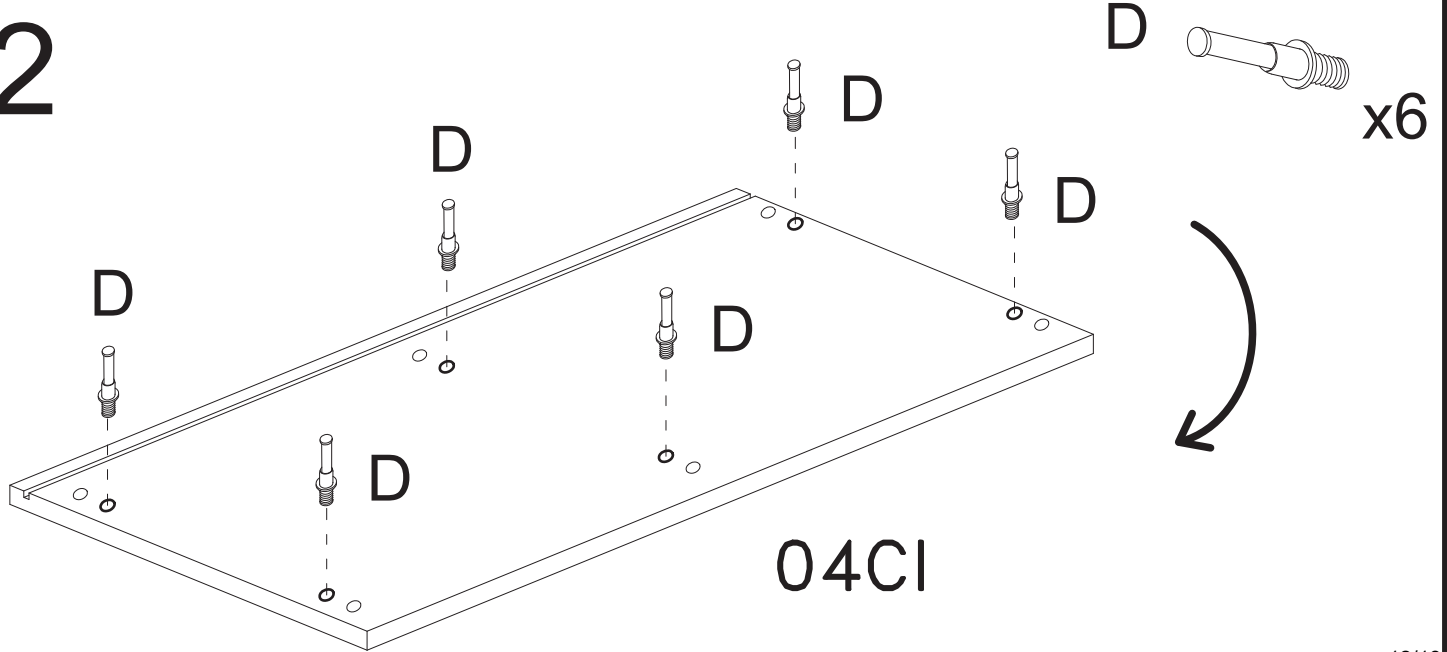

2

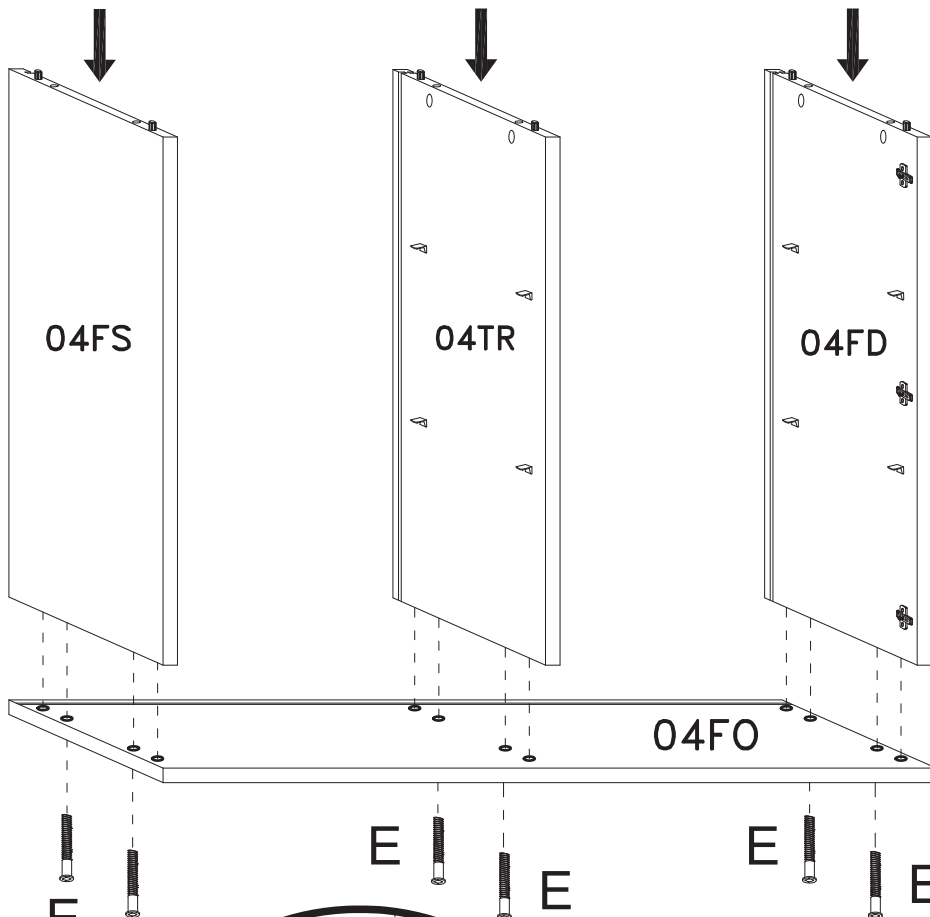

# 3

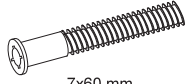

**E**  7x60 mm. x6

**V4530**  4.5x30 mm. x5

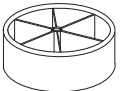
**P**  Ø 60 mm  
h 20 mm x5

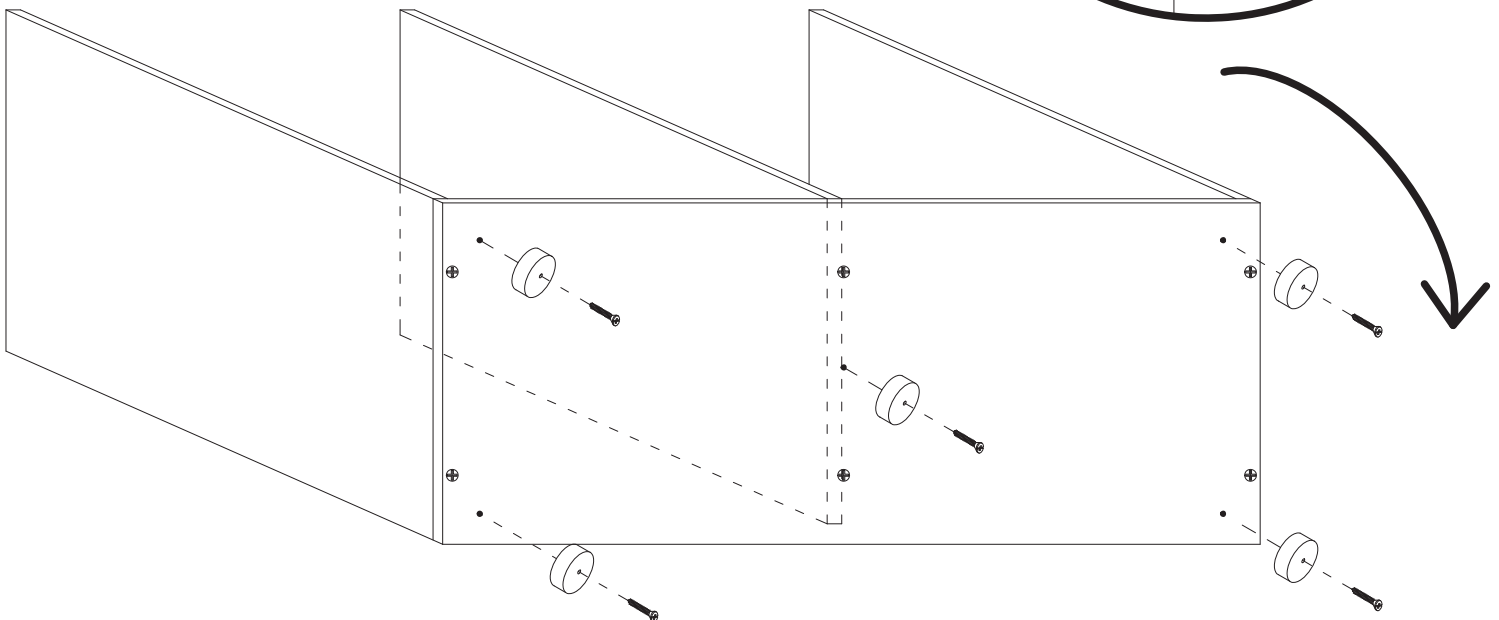
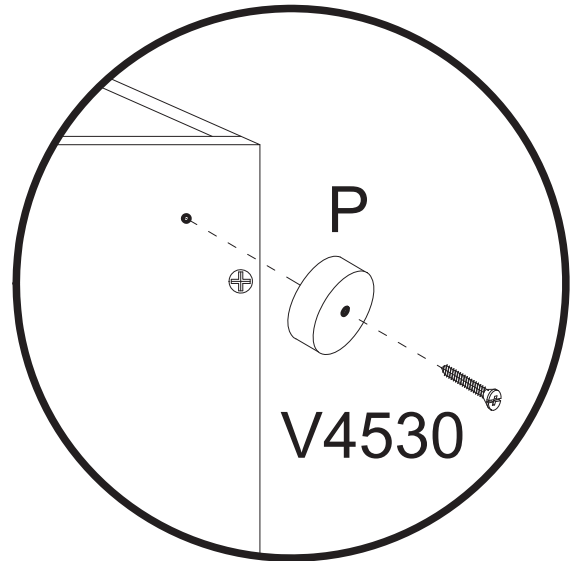
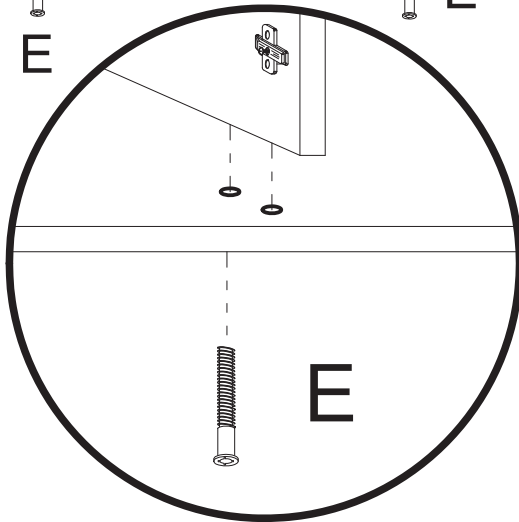

4

C

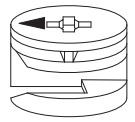

Ø15 mm.

x6

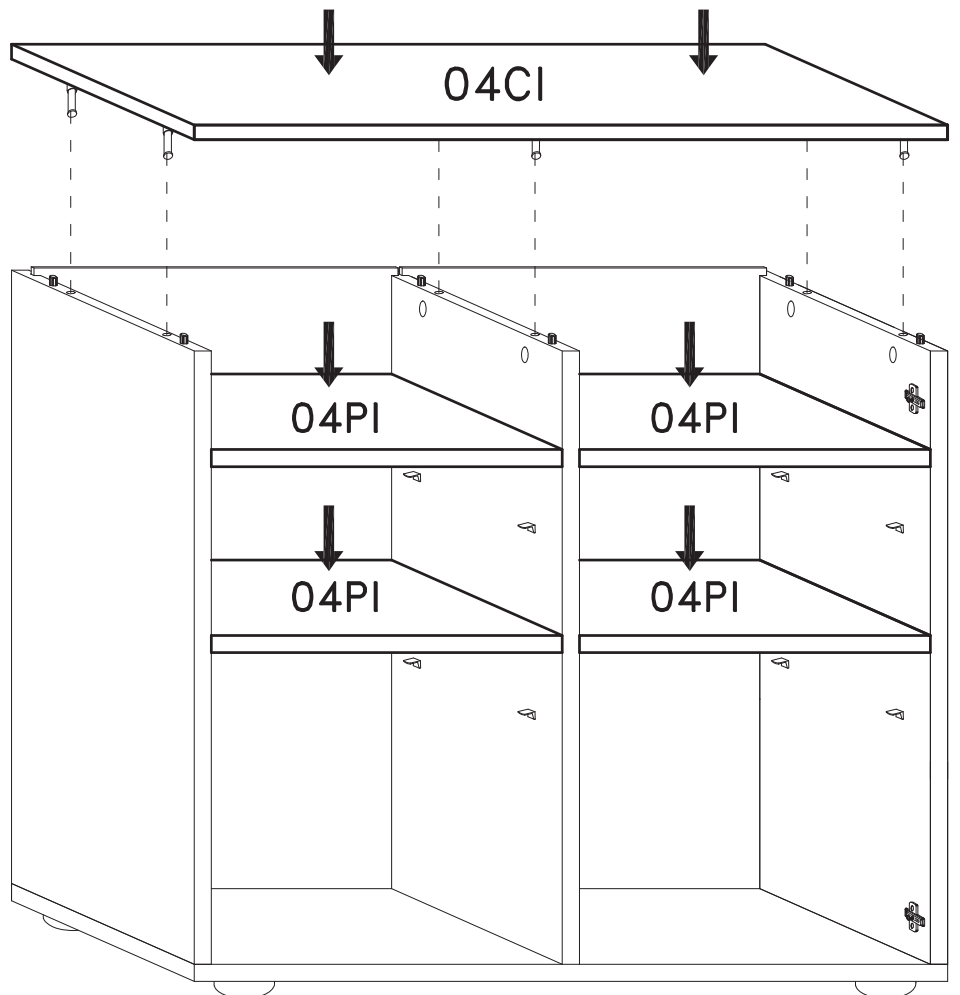
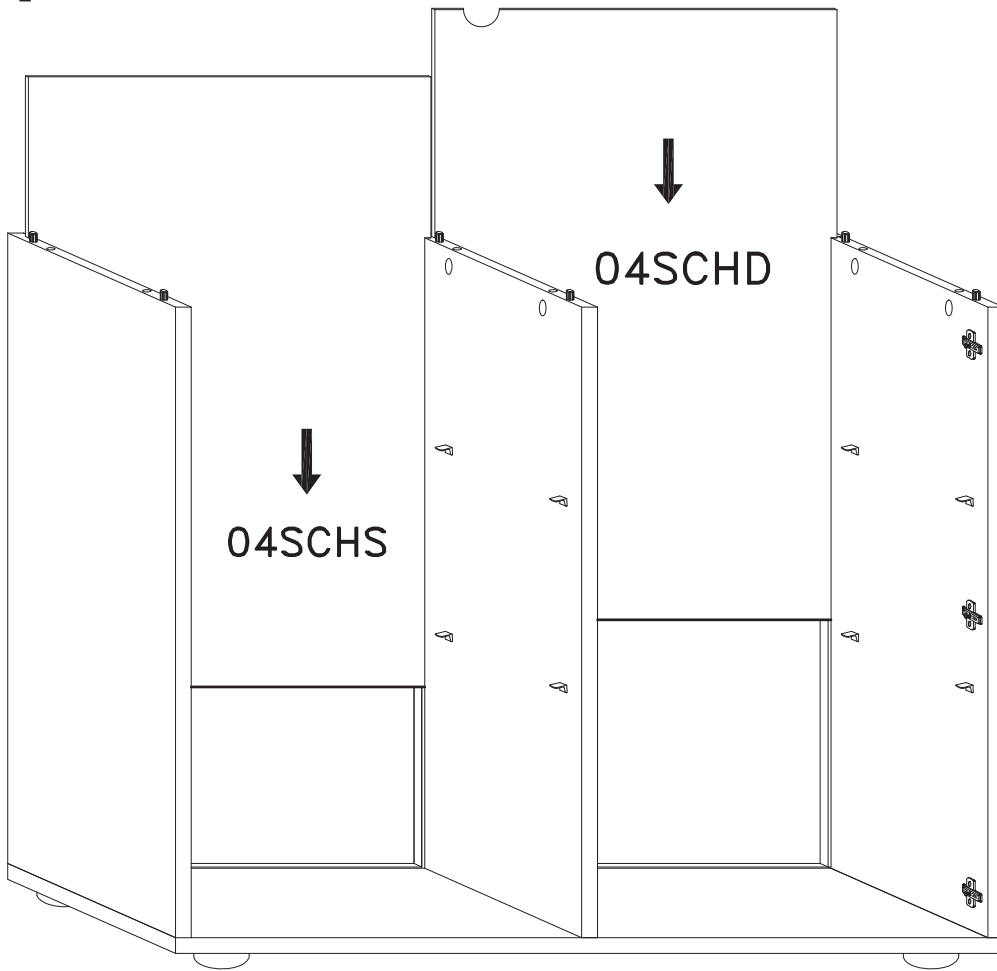

# 5

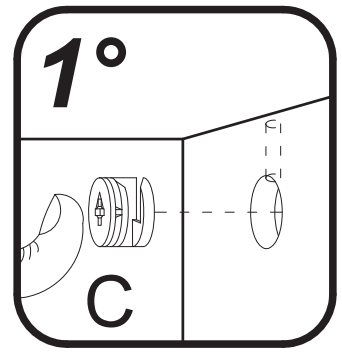
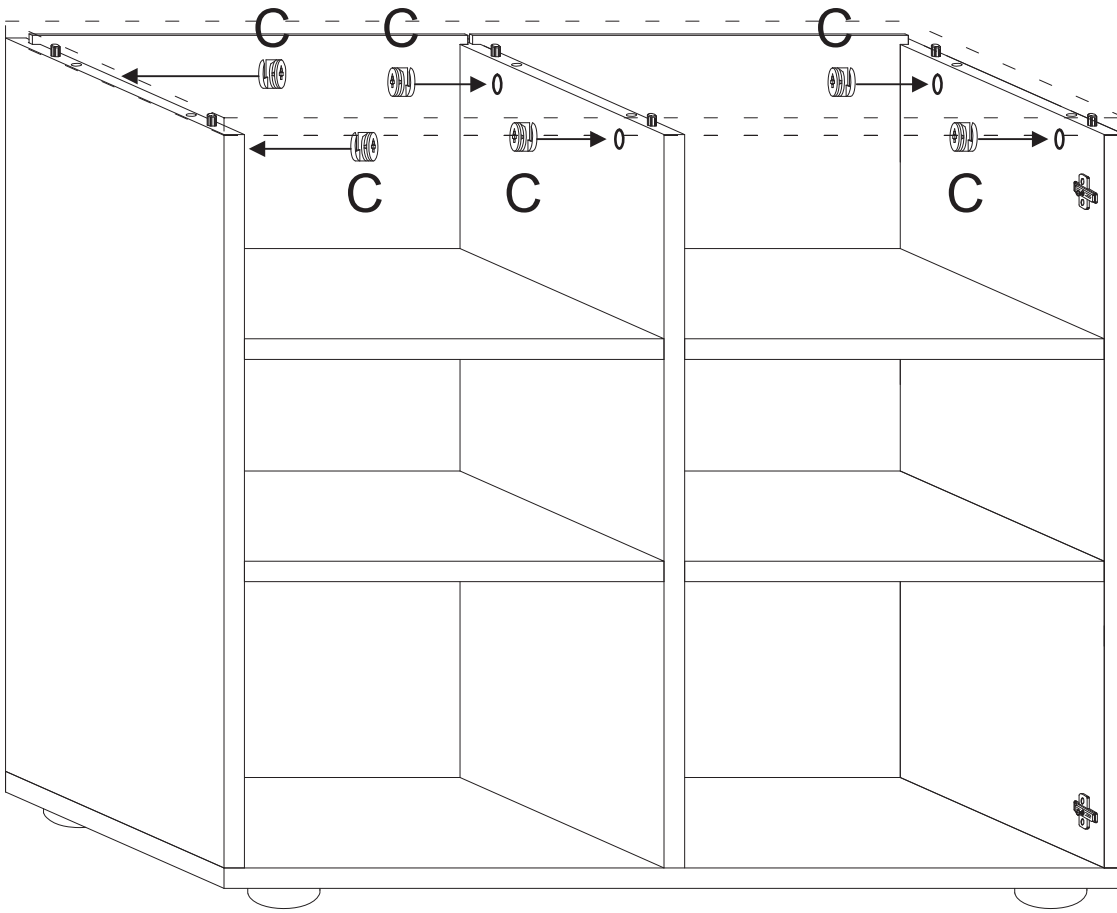

# 2°

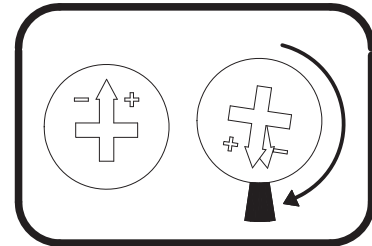
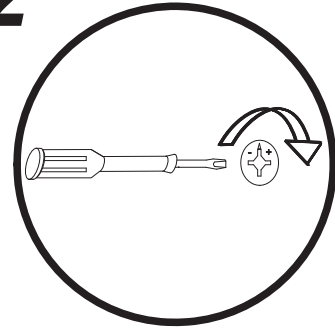

# 6

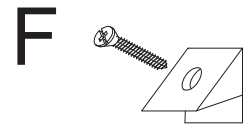
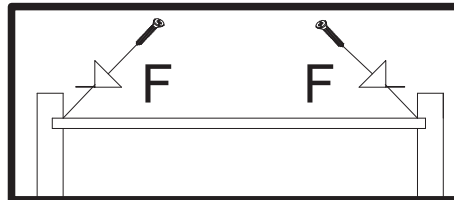

x20

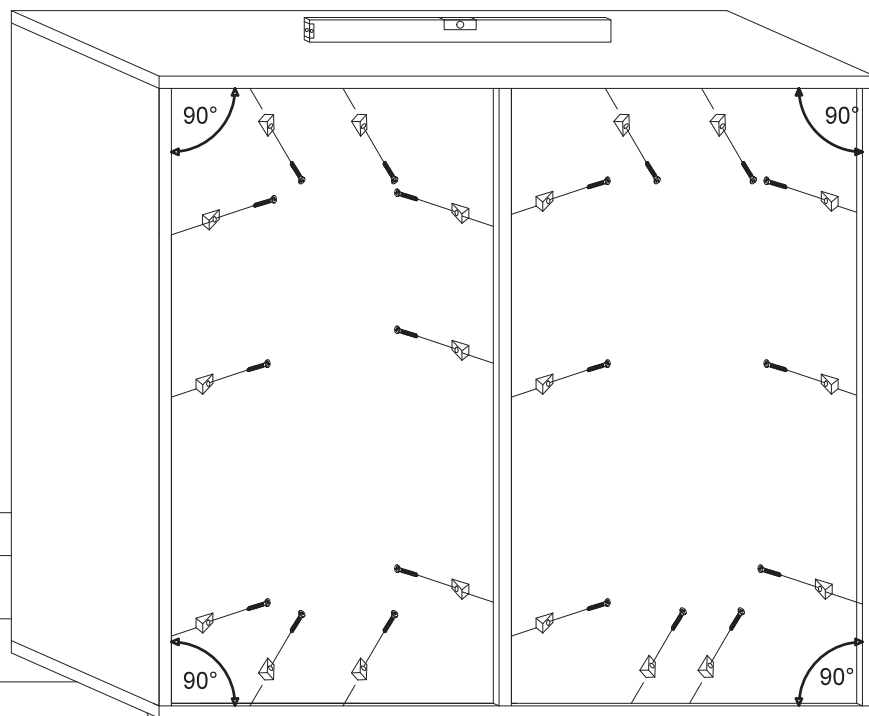

7

V415 x2

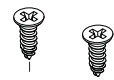

C0

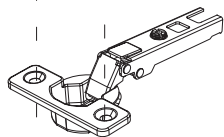

C0

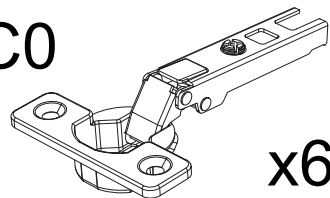

x6

V415

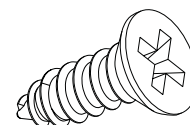

Ø4x15 x12

V415 x2

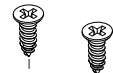

C0

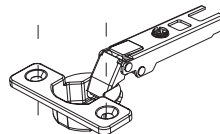

V415 x2

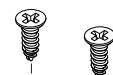

C0

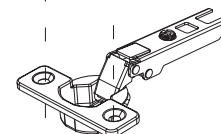

04SP x 2

V415

x 2

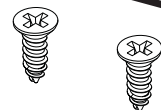

C0

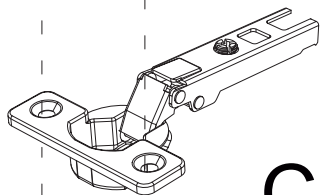

# 8

Vážený zákazníku, montáž závěsných prvků musí provádět kvalifikovaný personál.

Hmoždinky nejsou součástí balení.

Vyberte hmoždinky, které jsou nejvhodnější pro daný typ stěny.

Ujistěte se, že stěna je vhodná pro bezpečné uchycení závěsného prvku.

Vážený zákazník, montáž závesných prvkov musí vykonáva kvalifikovaný personál.

Hmoždinky nie sú súčasťou balenia.

Vyberte hmoždinky, ktoré sú najvhodnejšie pre daný typ steny.

Uistite sa, že stena je vhodná na bezpečné upevnenie závesného prvku.

PST  
x1

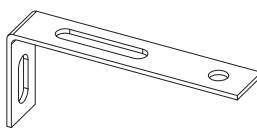

V418  
x2

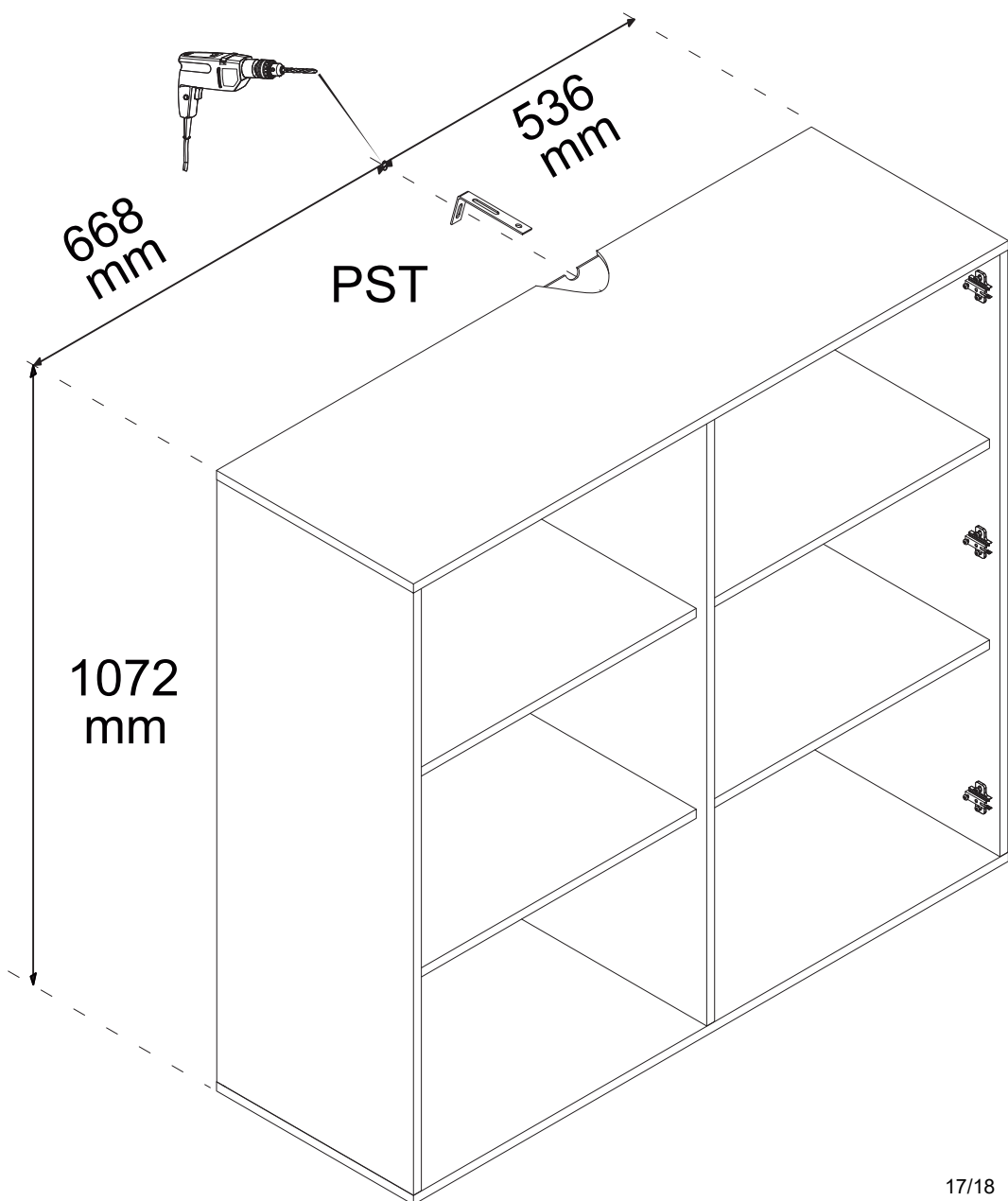
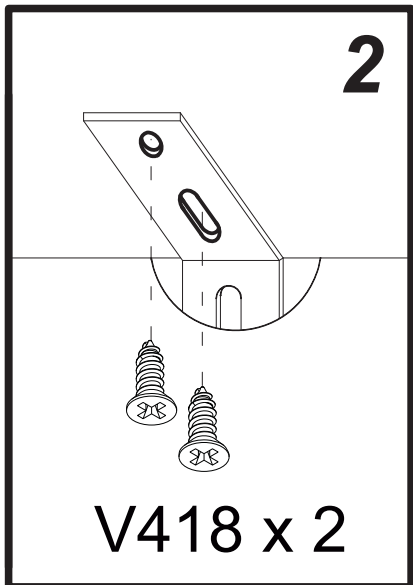
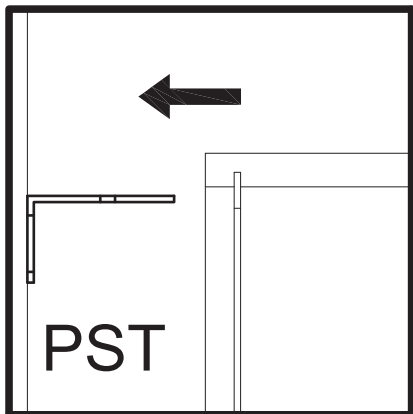
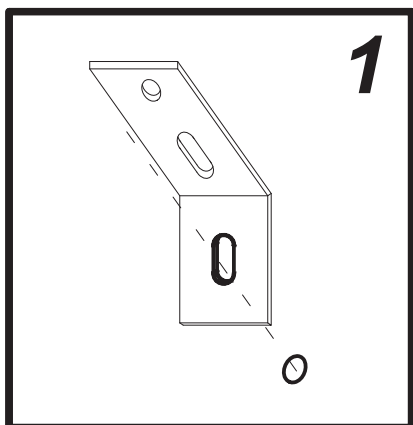
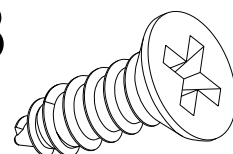

9

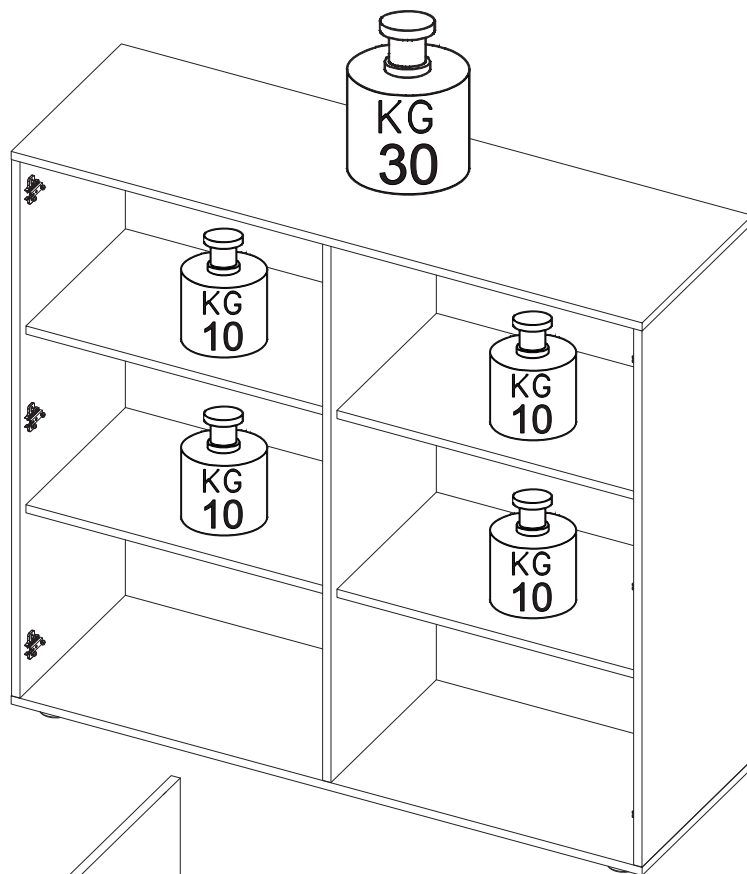
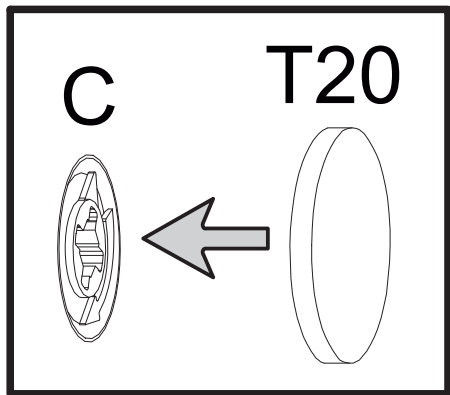

G



x4

T20



x6

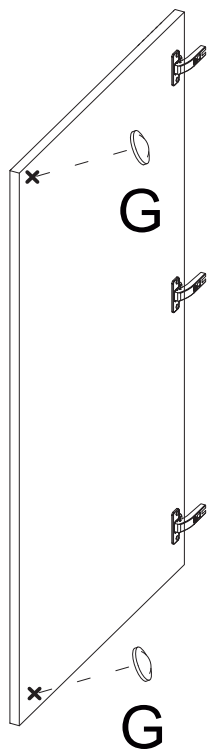

**04SP**

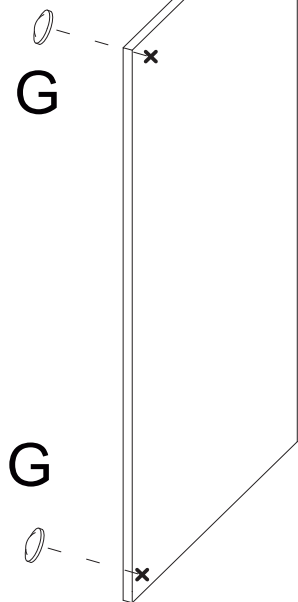

**04SP**

