

# ŠATNÍ SKŘÍŇ ŠATNÍKOVÁ SKŘIŇA HEDWIG

Montážní/Montážny návod

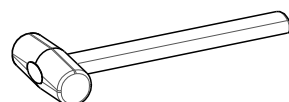

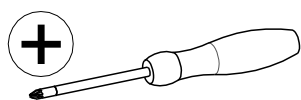
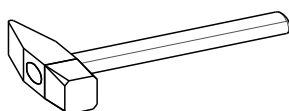
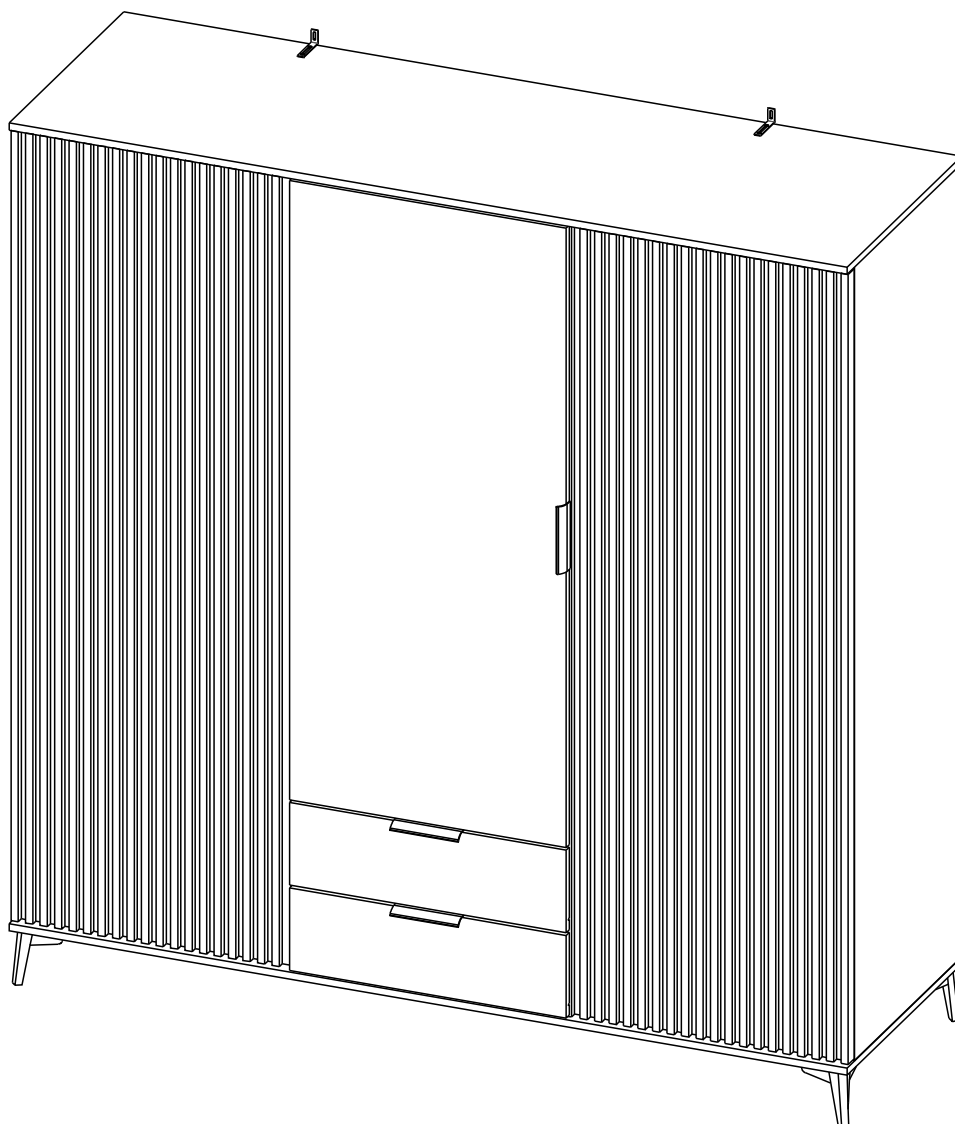
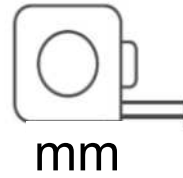
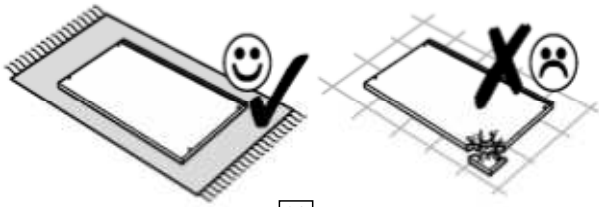

NR	il.	szer. [mm]	dl. [mm]
1	1	559	1768
2	1	559	1768
3	1	584	1768
4	1	584	1768
5	1	600	1850
6	1	600	1850
7	2	559	598
8	1	582	588
9	3	582	588
10	3	614	1794
11	1	611	1380
12	2	611	1760
13	2	184	611
14	2	130	350
15	2	130	350
16	2	353	539
17	2	103	531

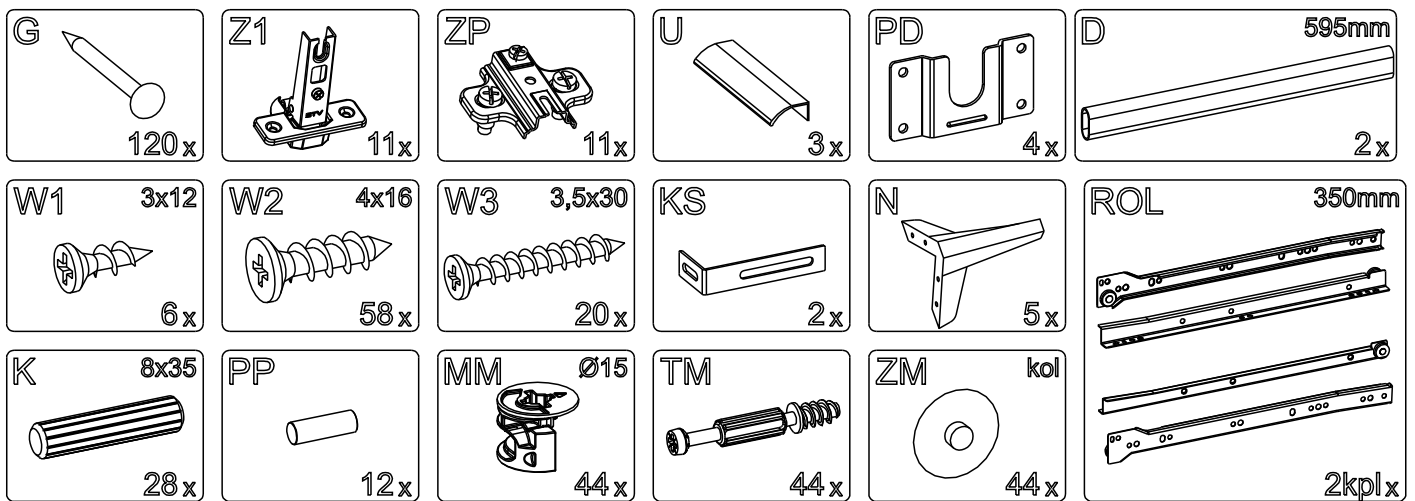
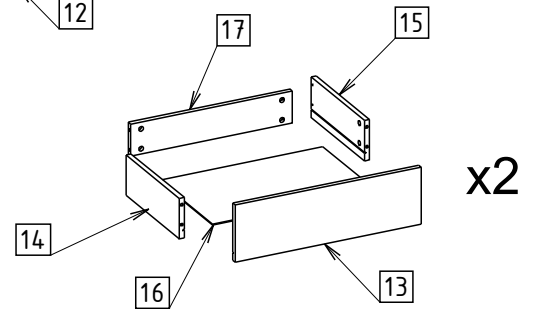
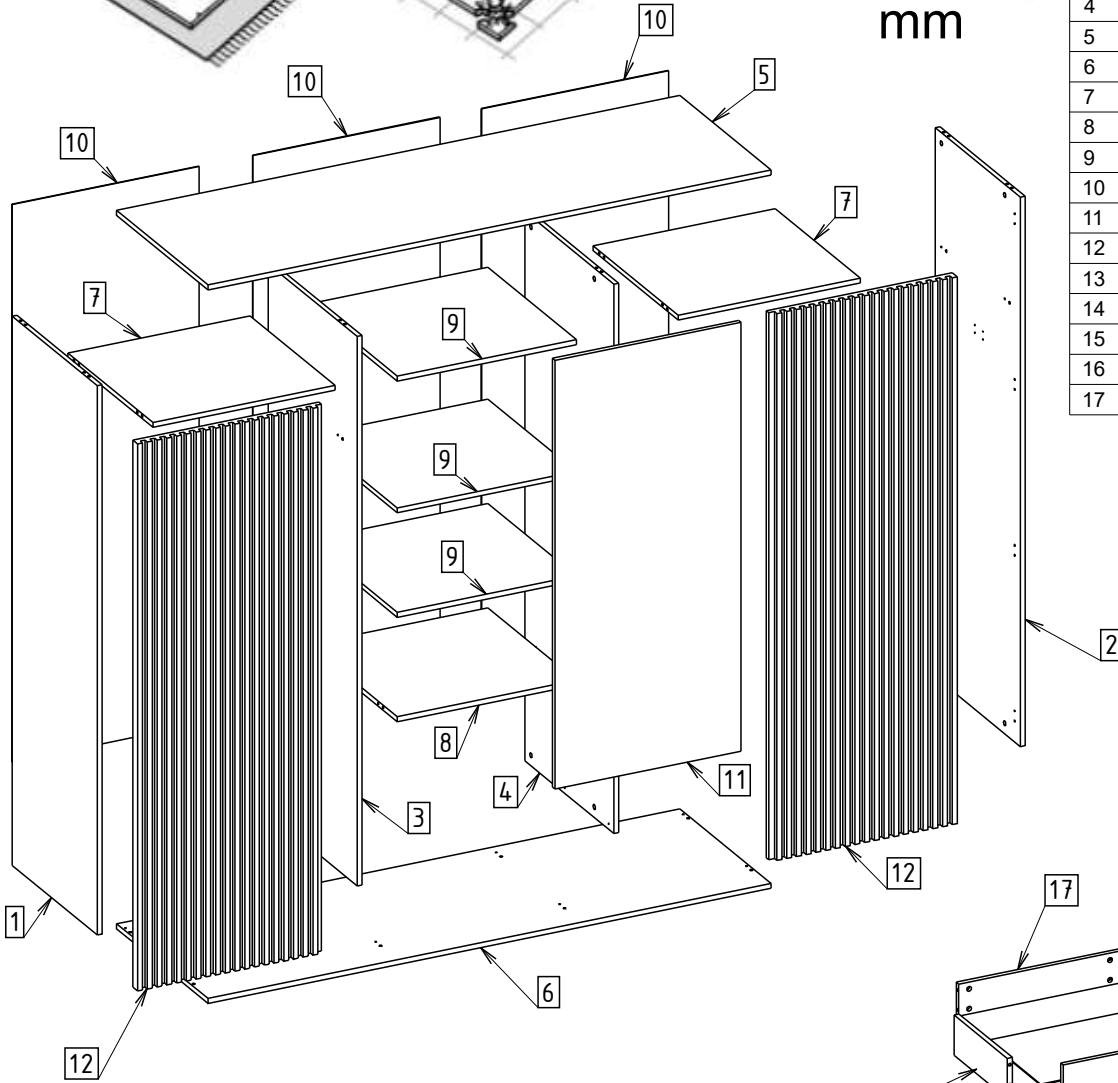

1

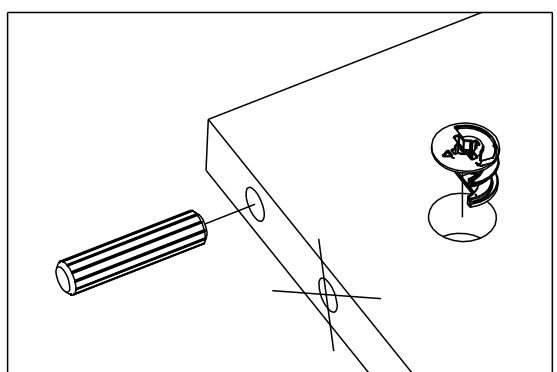
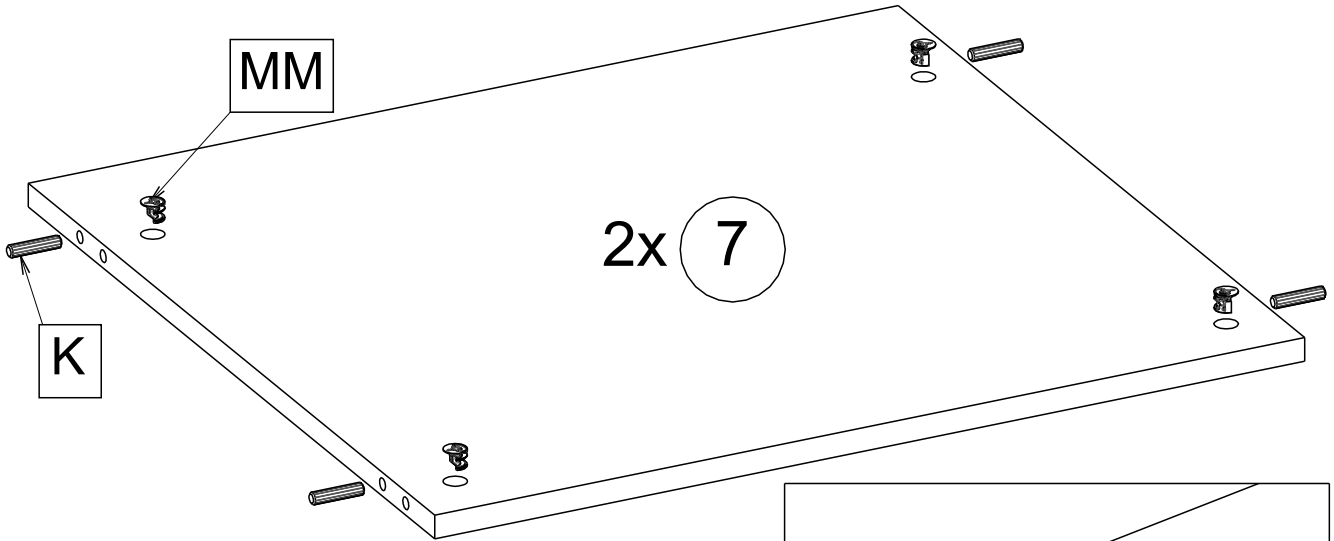
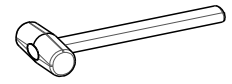
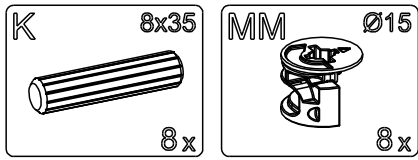

2

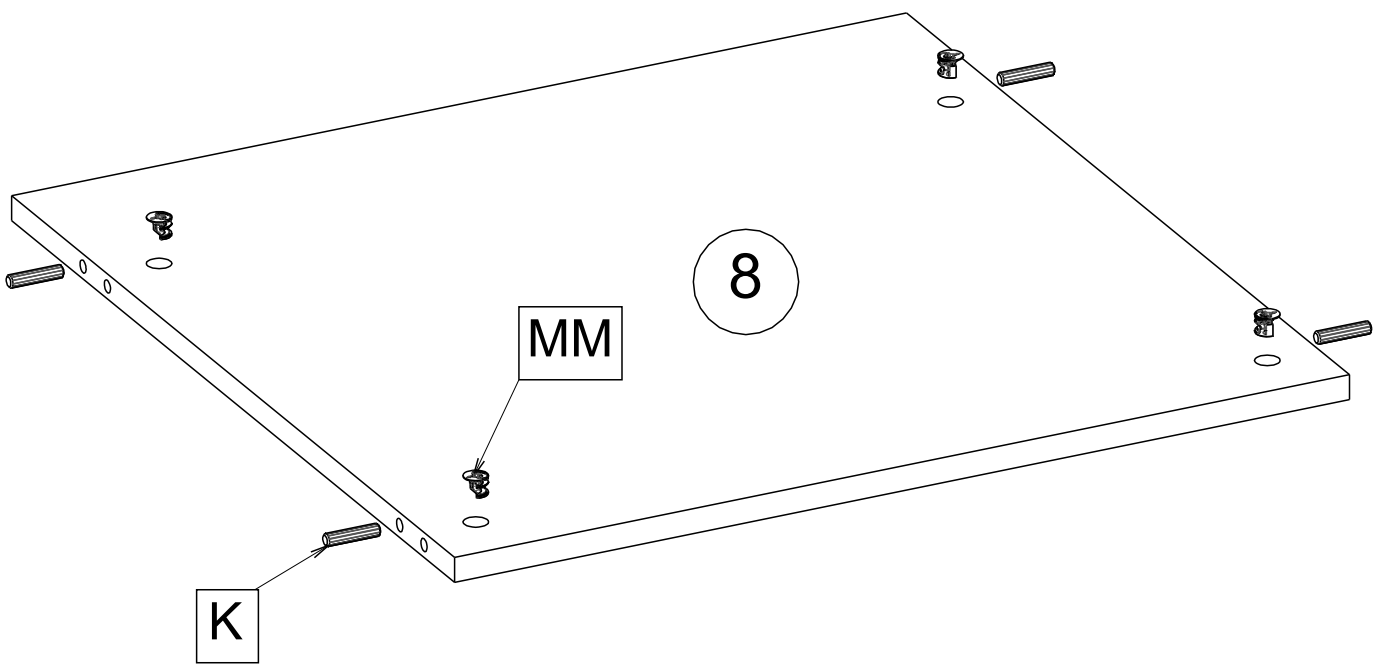
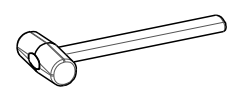
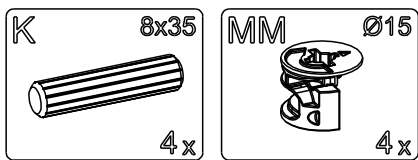

3

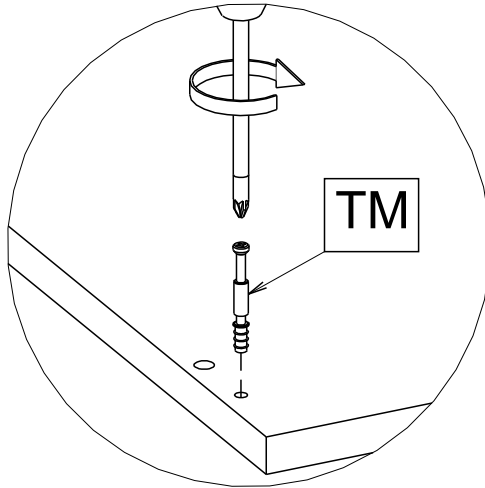
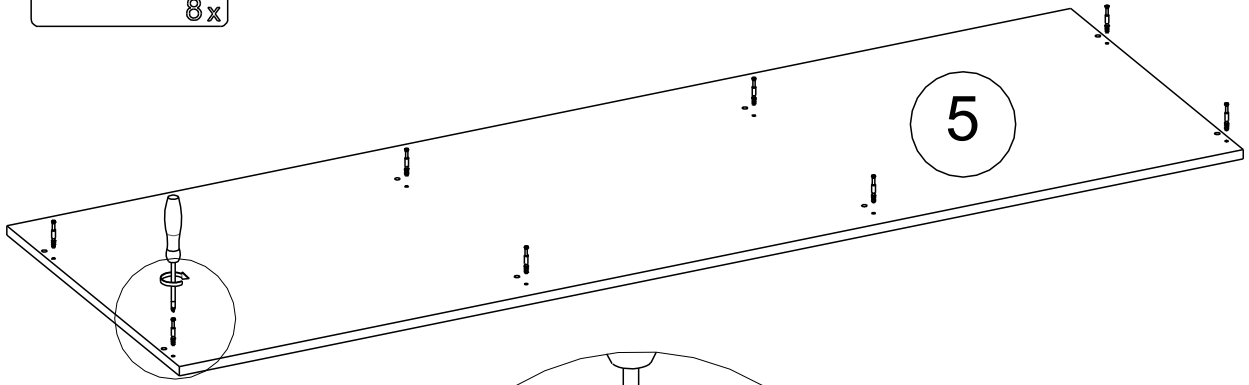
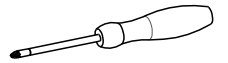
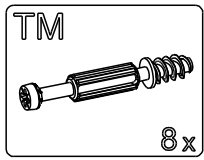

4

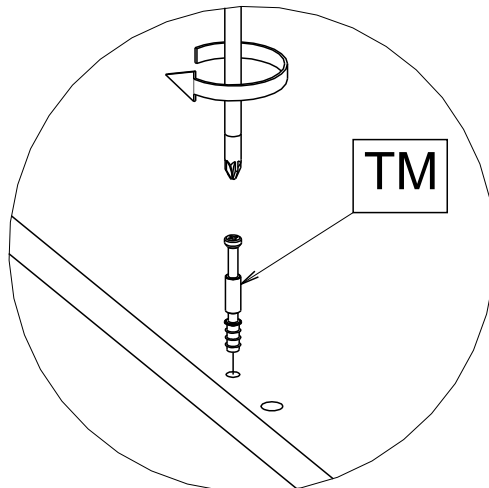
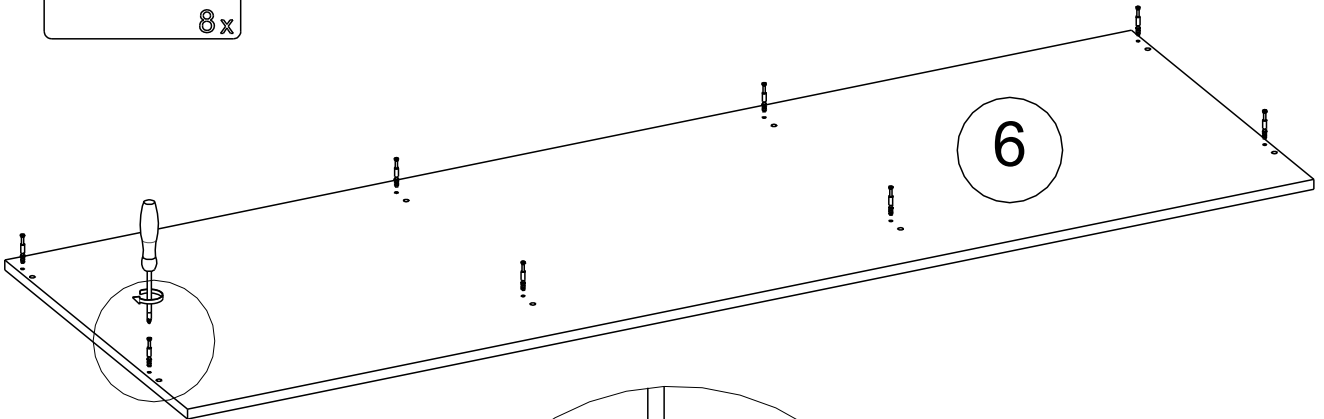
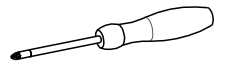
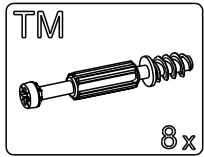

5

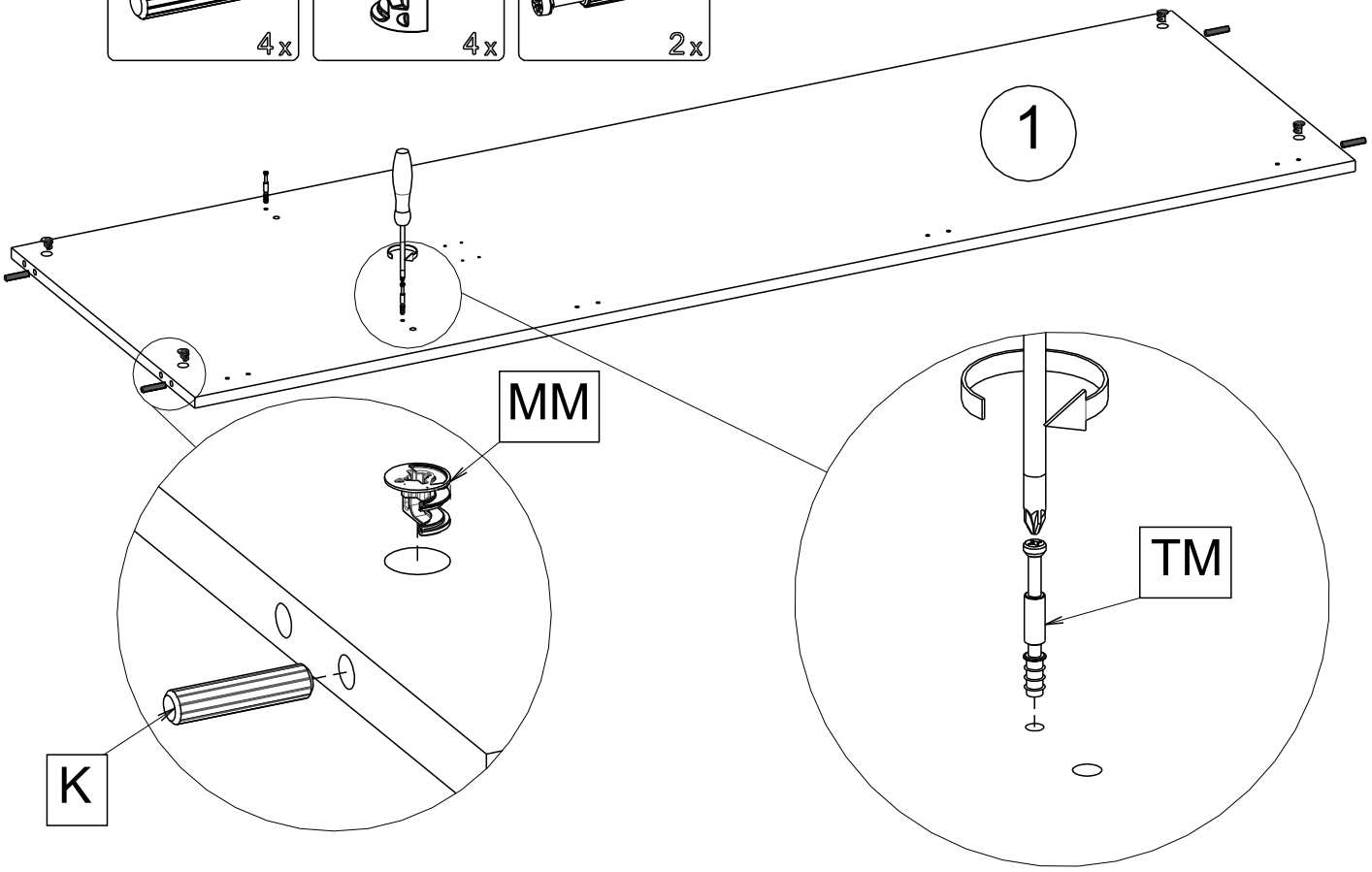
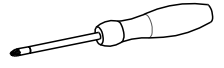
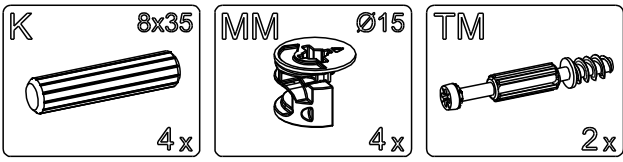

6

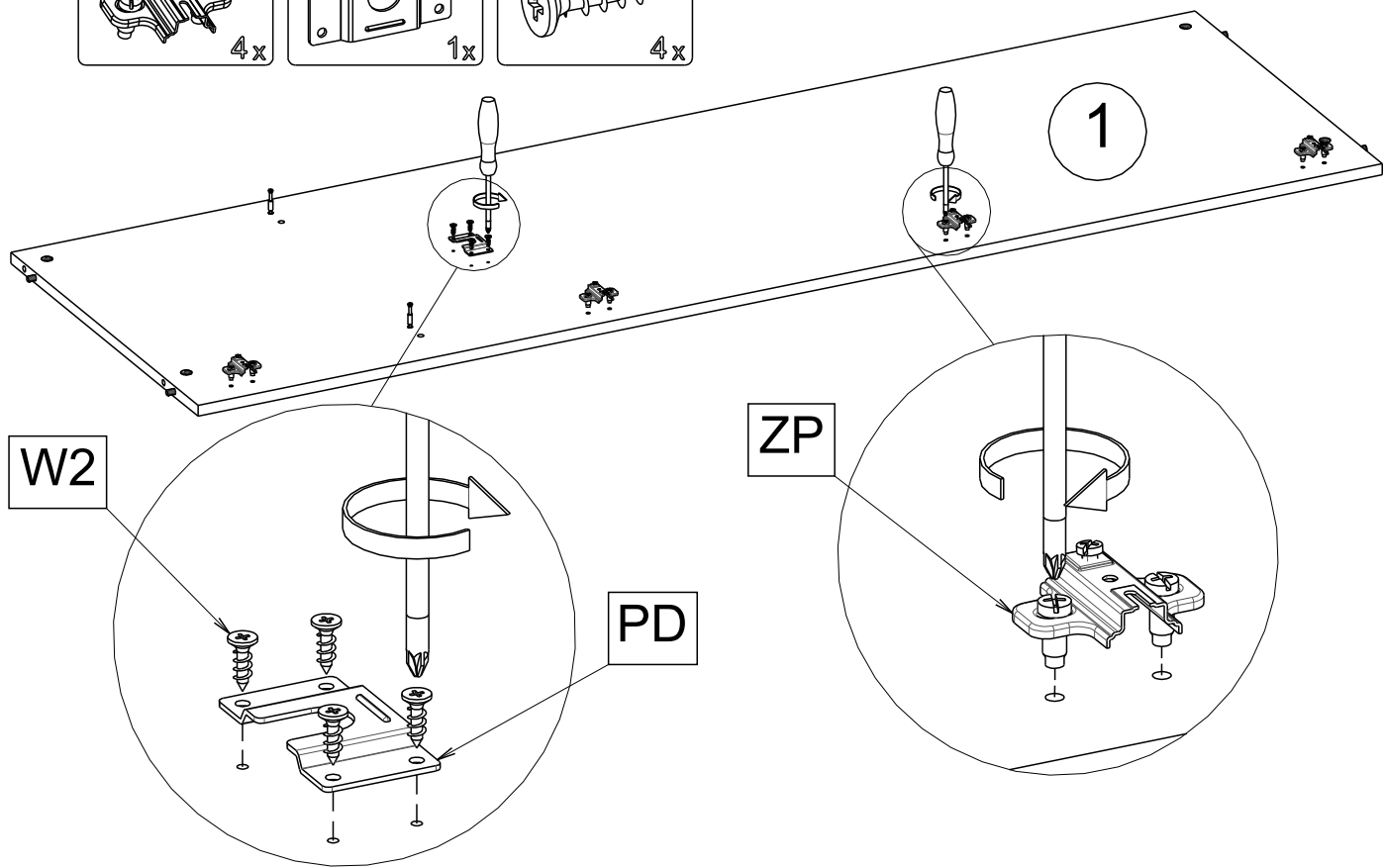
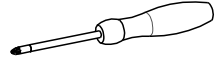
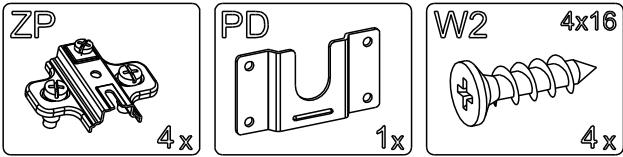

7

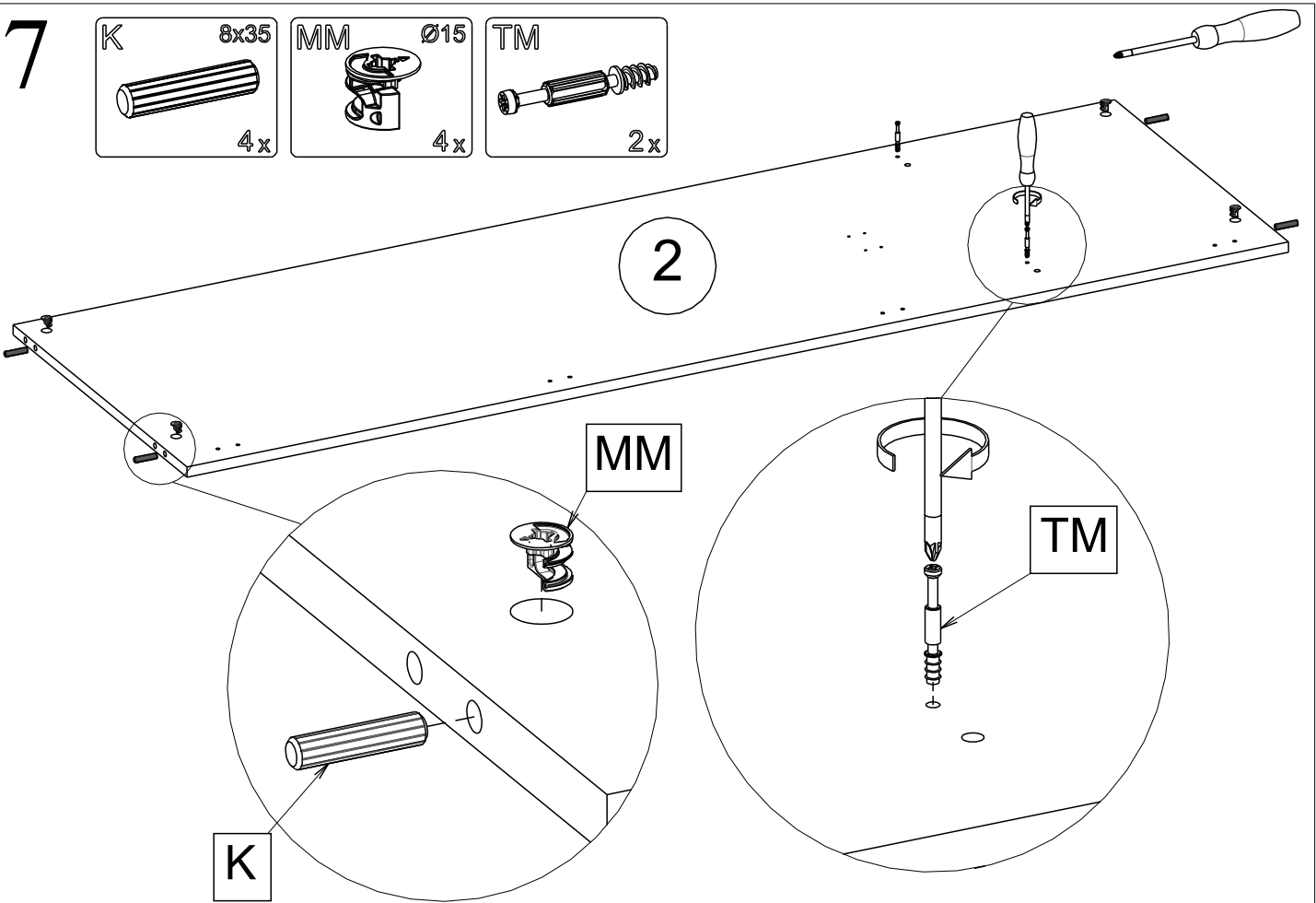
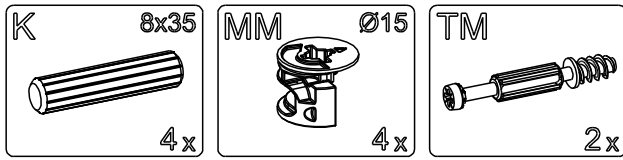

8

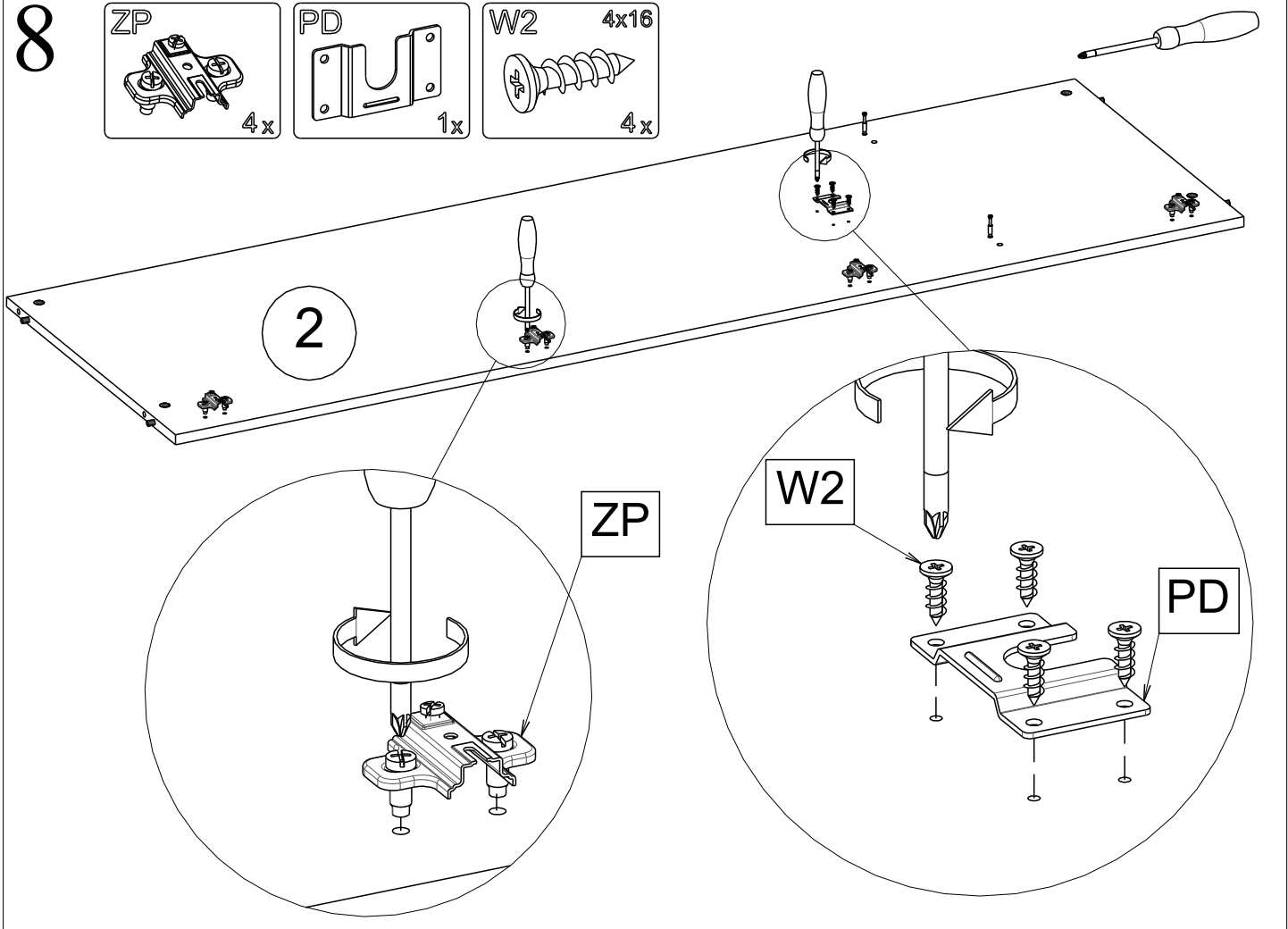
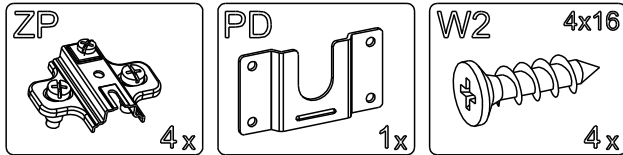

9

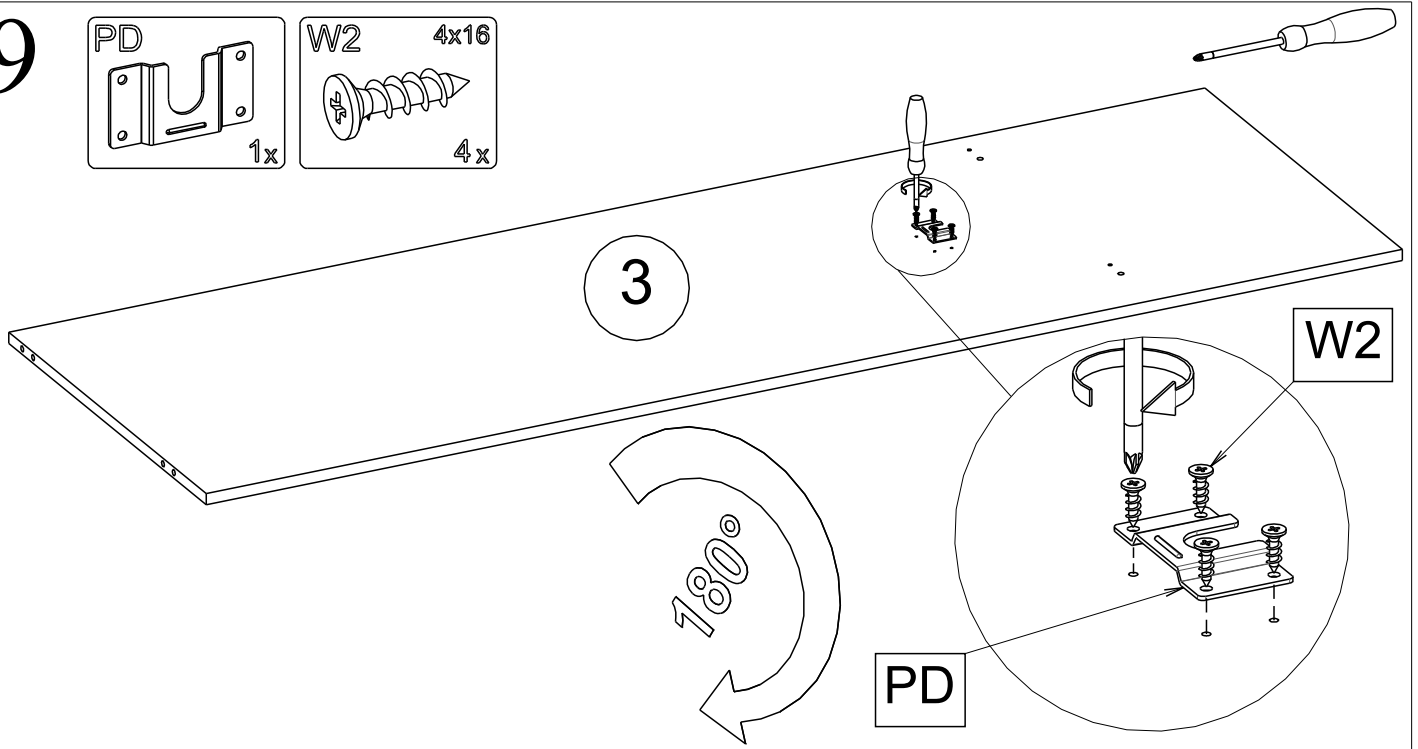
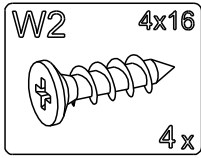
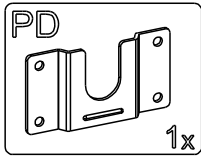

10

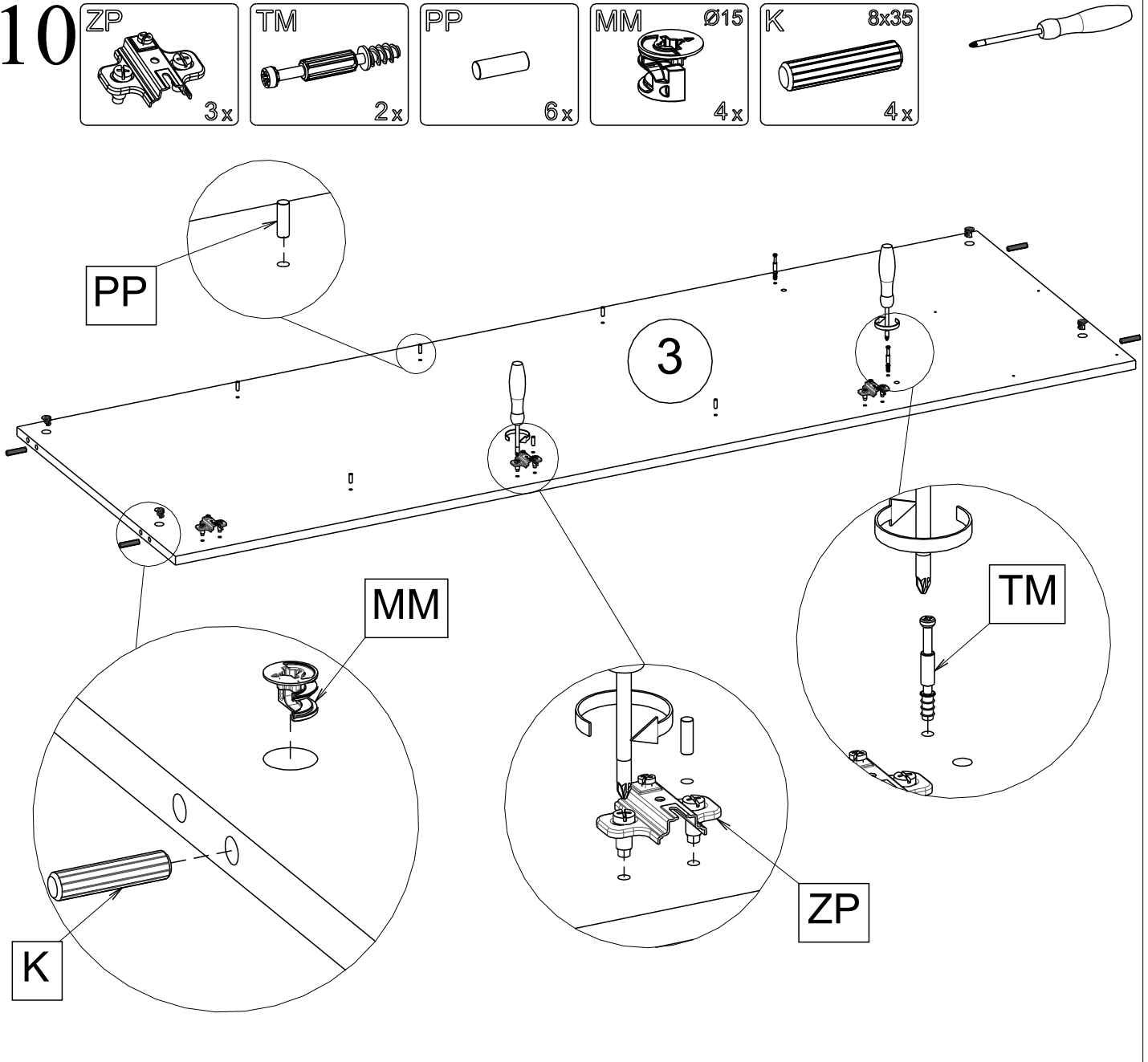
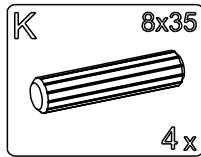
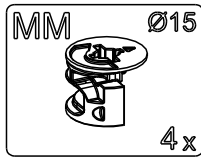
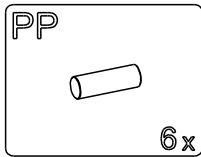
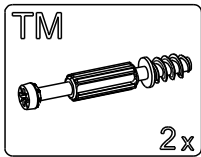
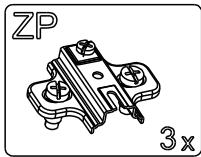

# 11

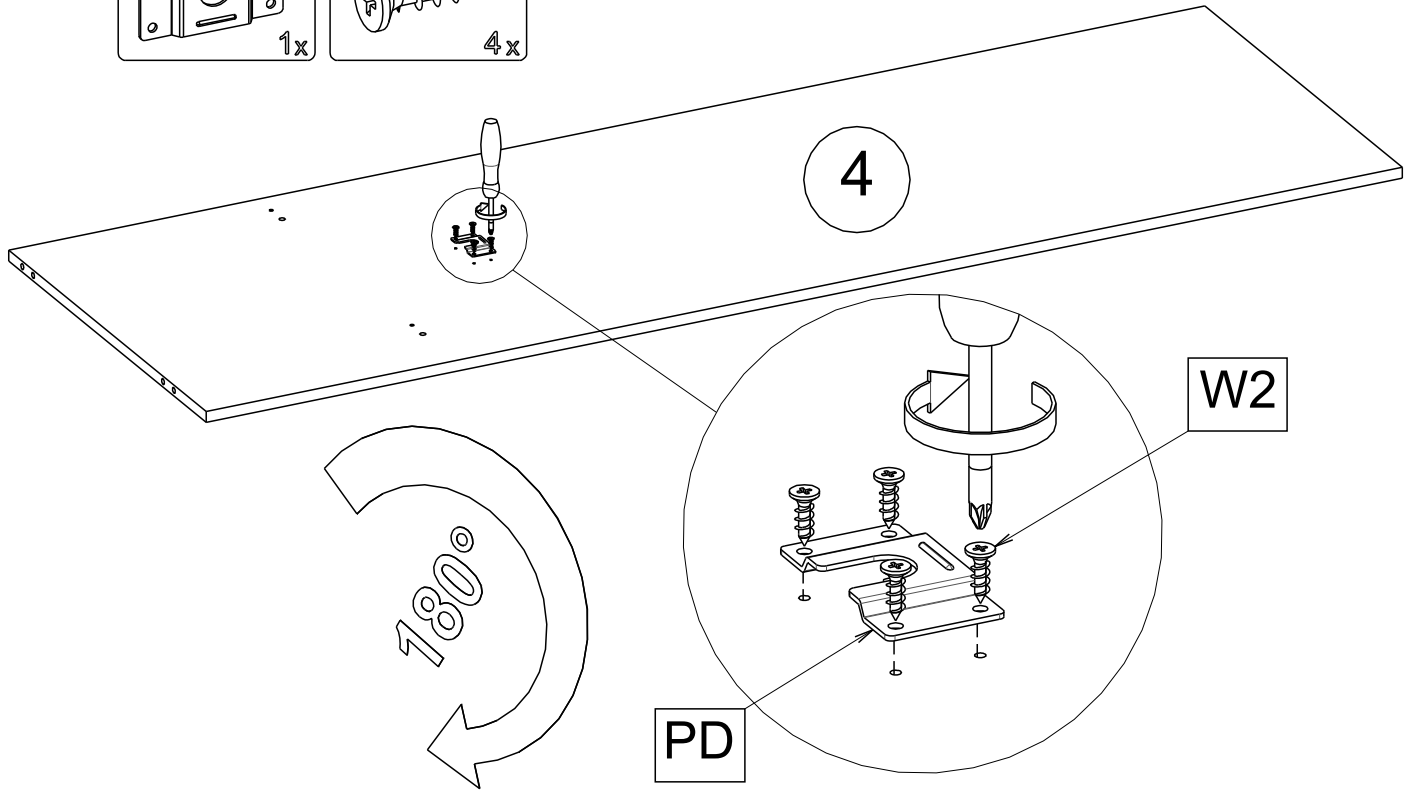
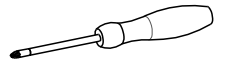
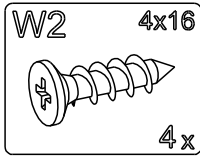
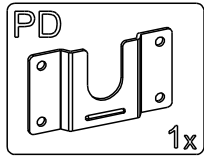

# 12

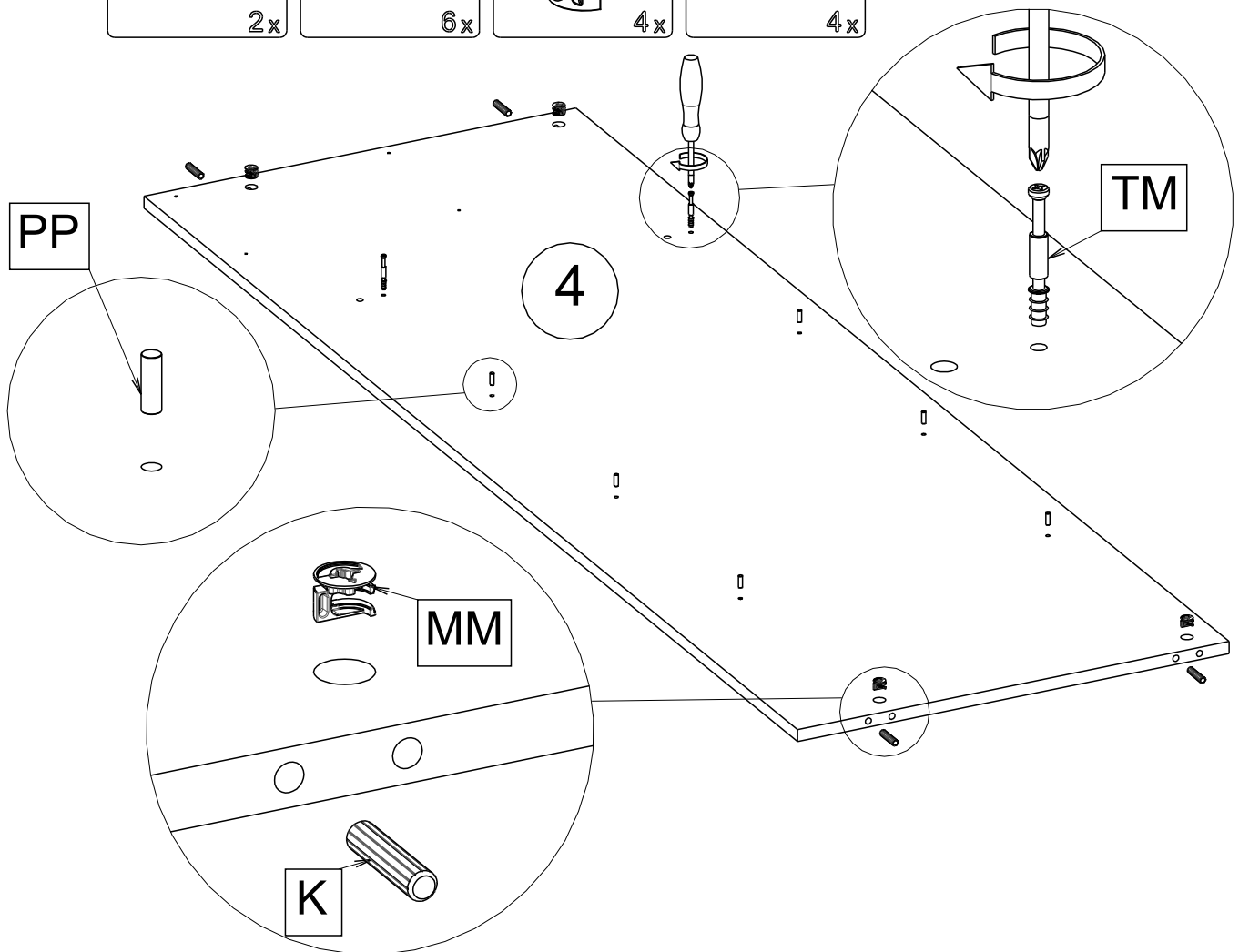
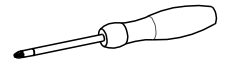
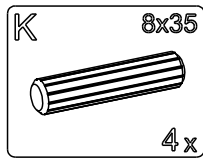
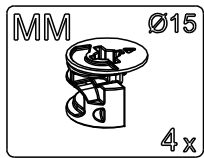
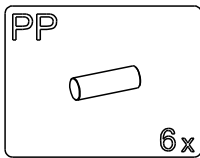
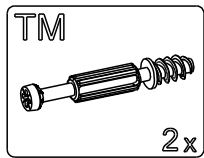



# 13

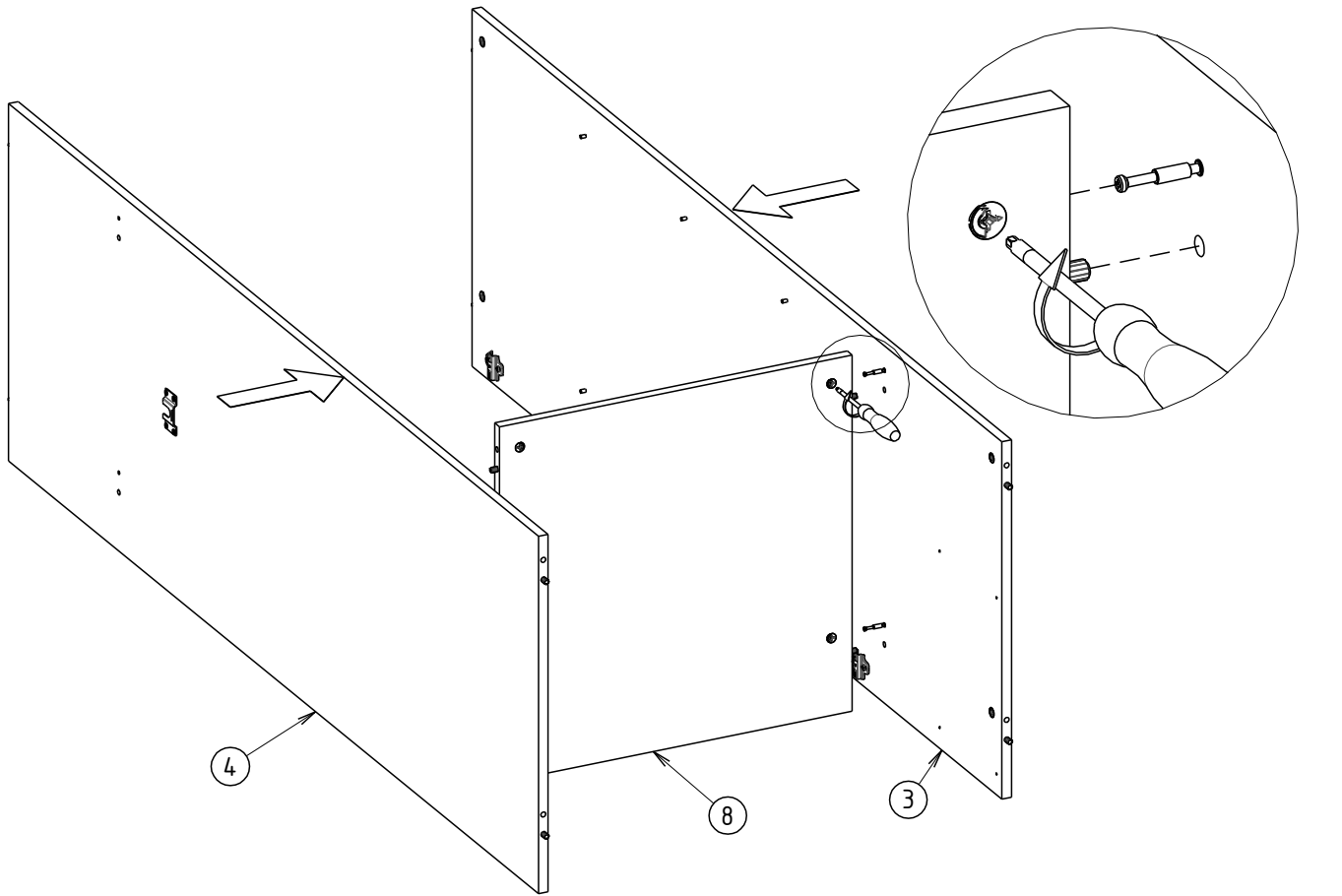

# 14

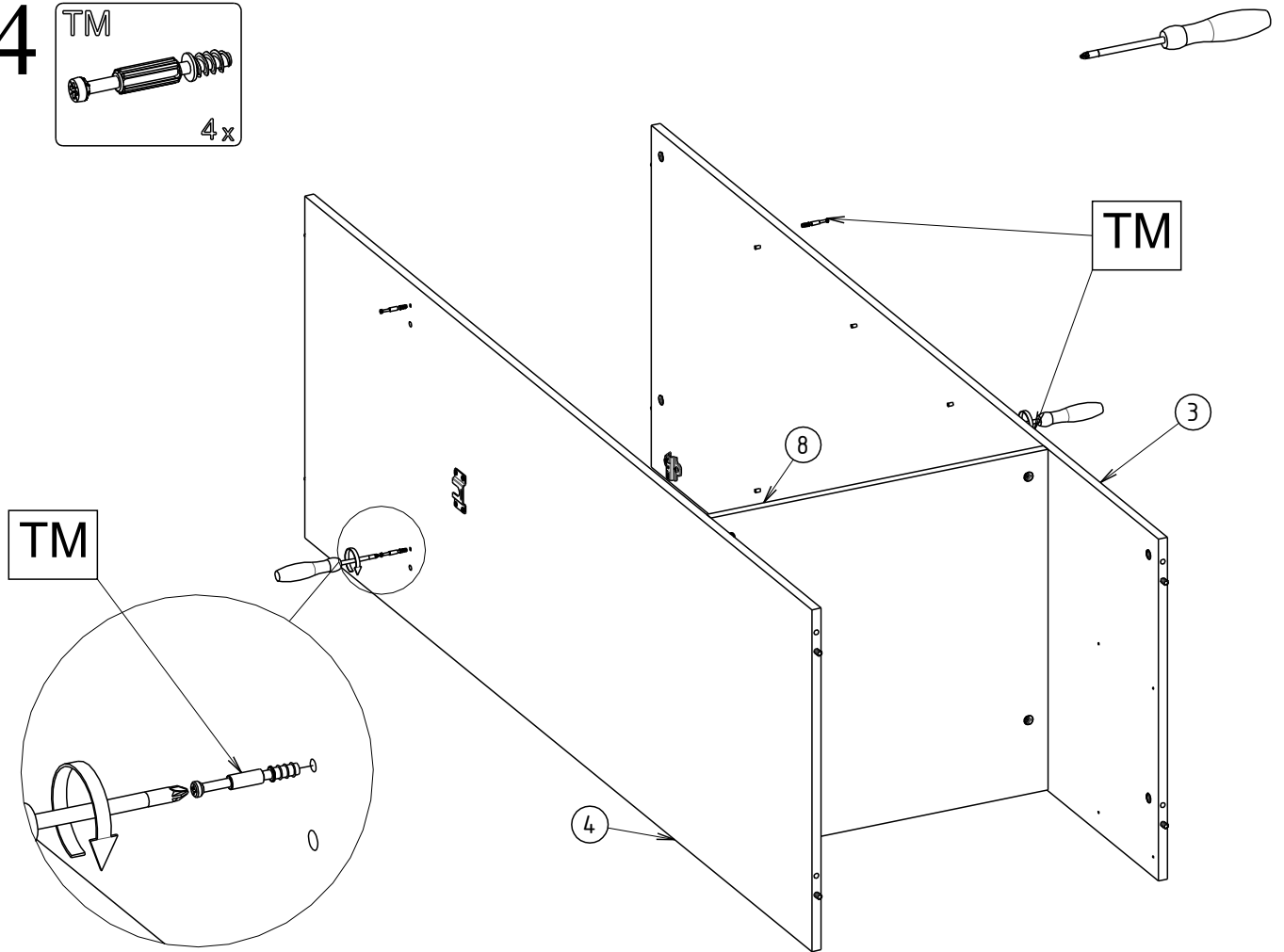
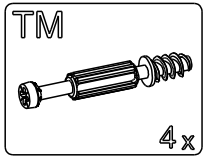

# 15

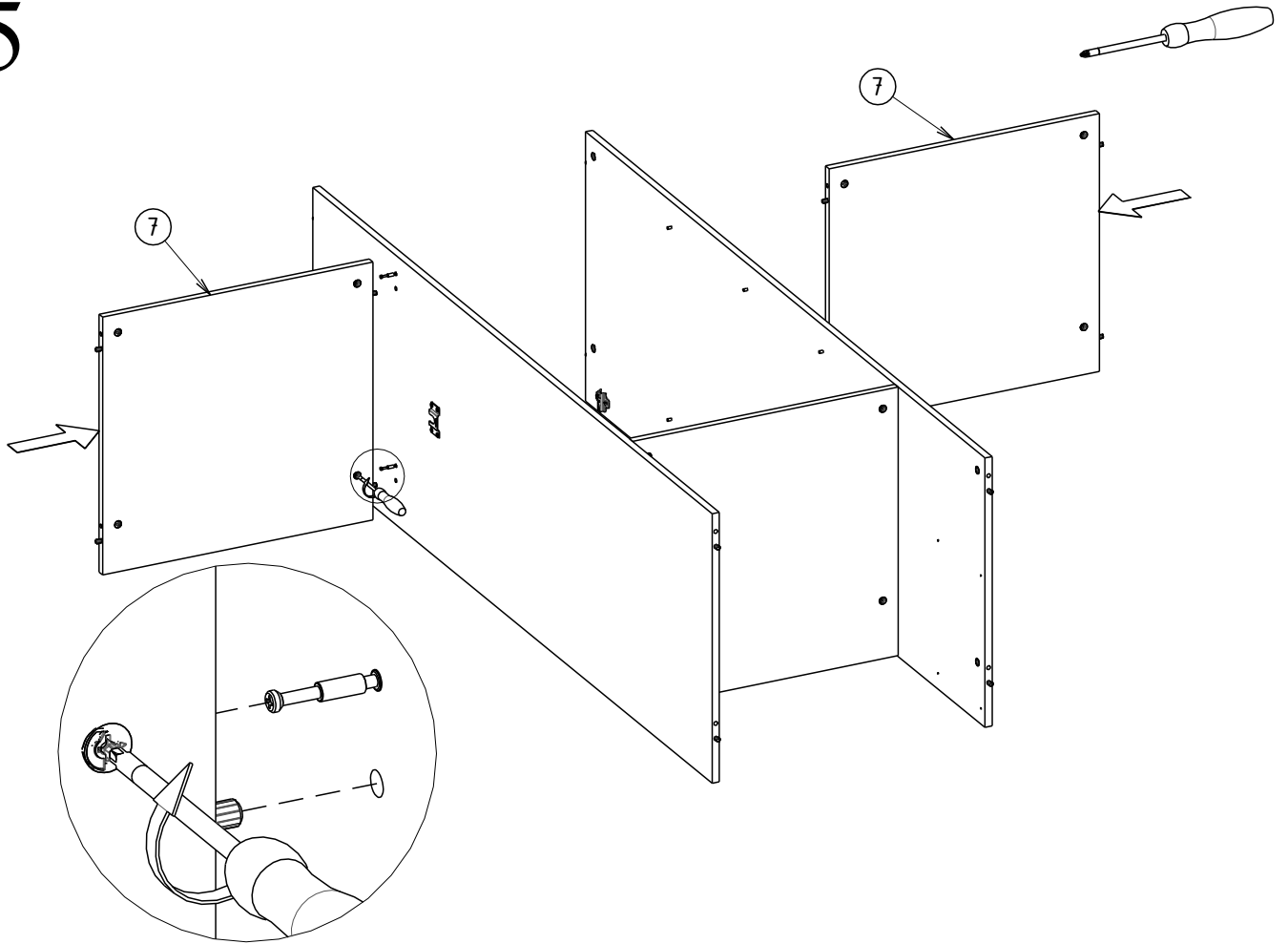

# 16

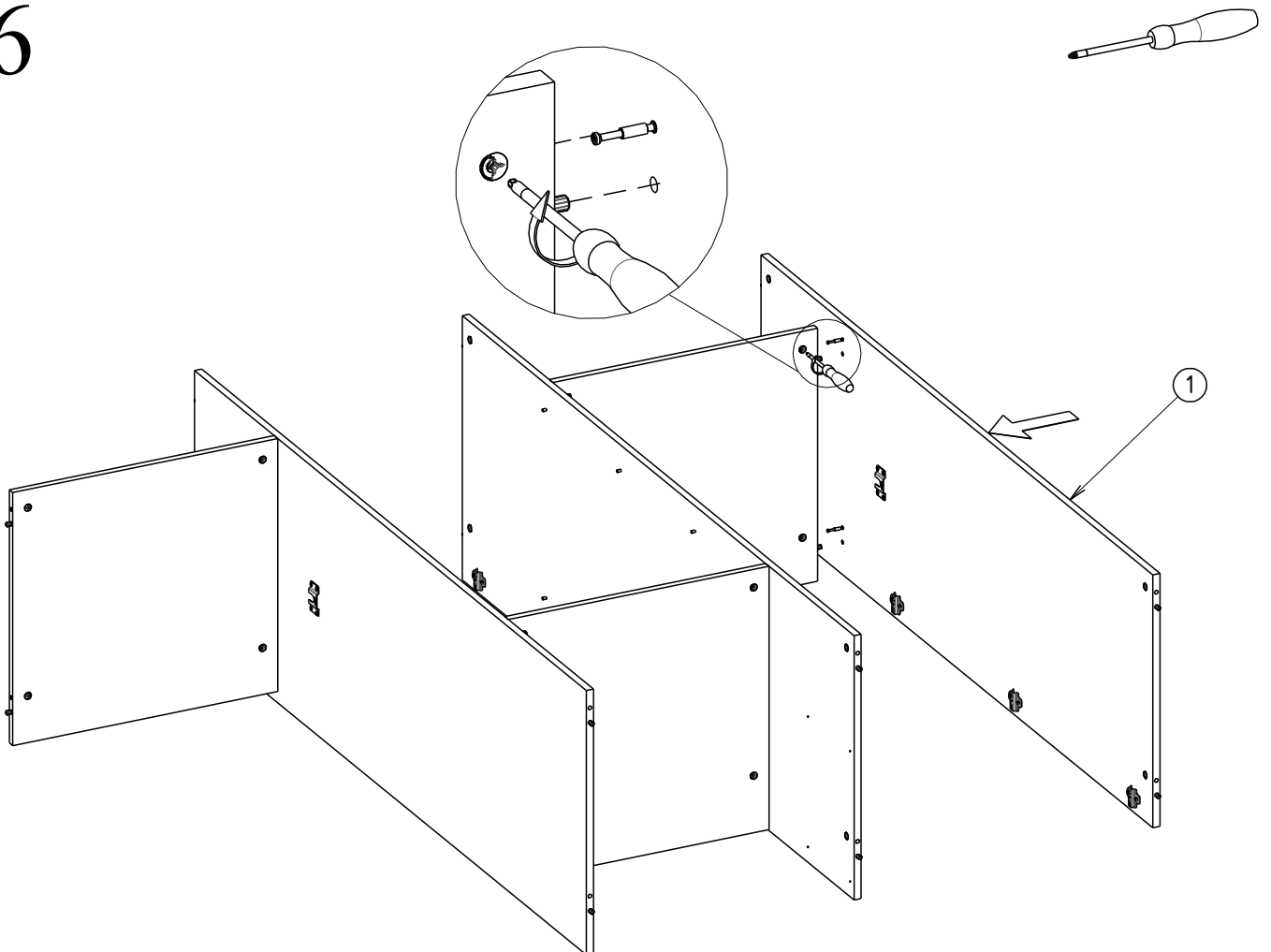

# 17

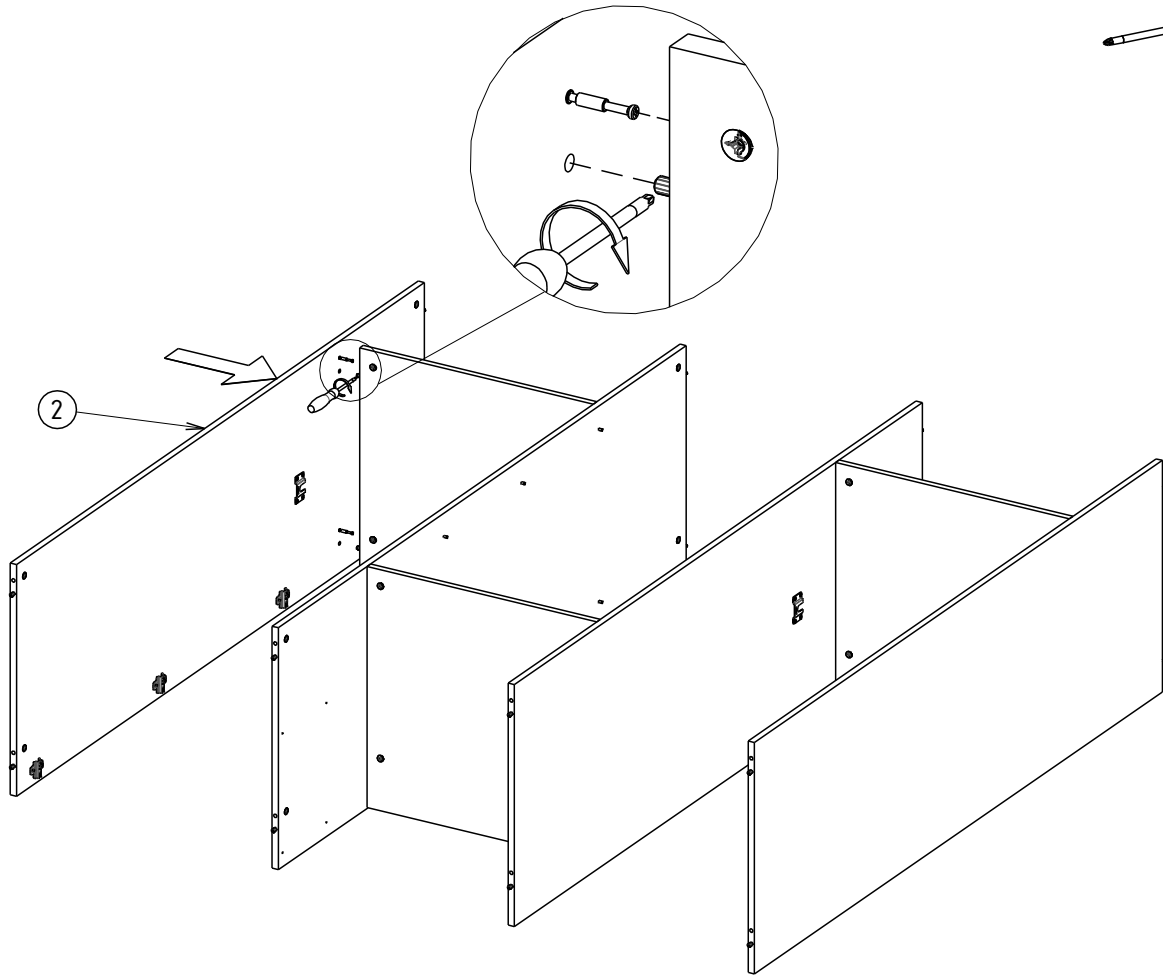

# 18

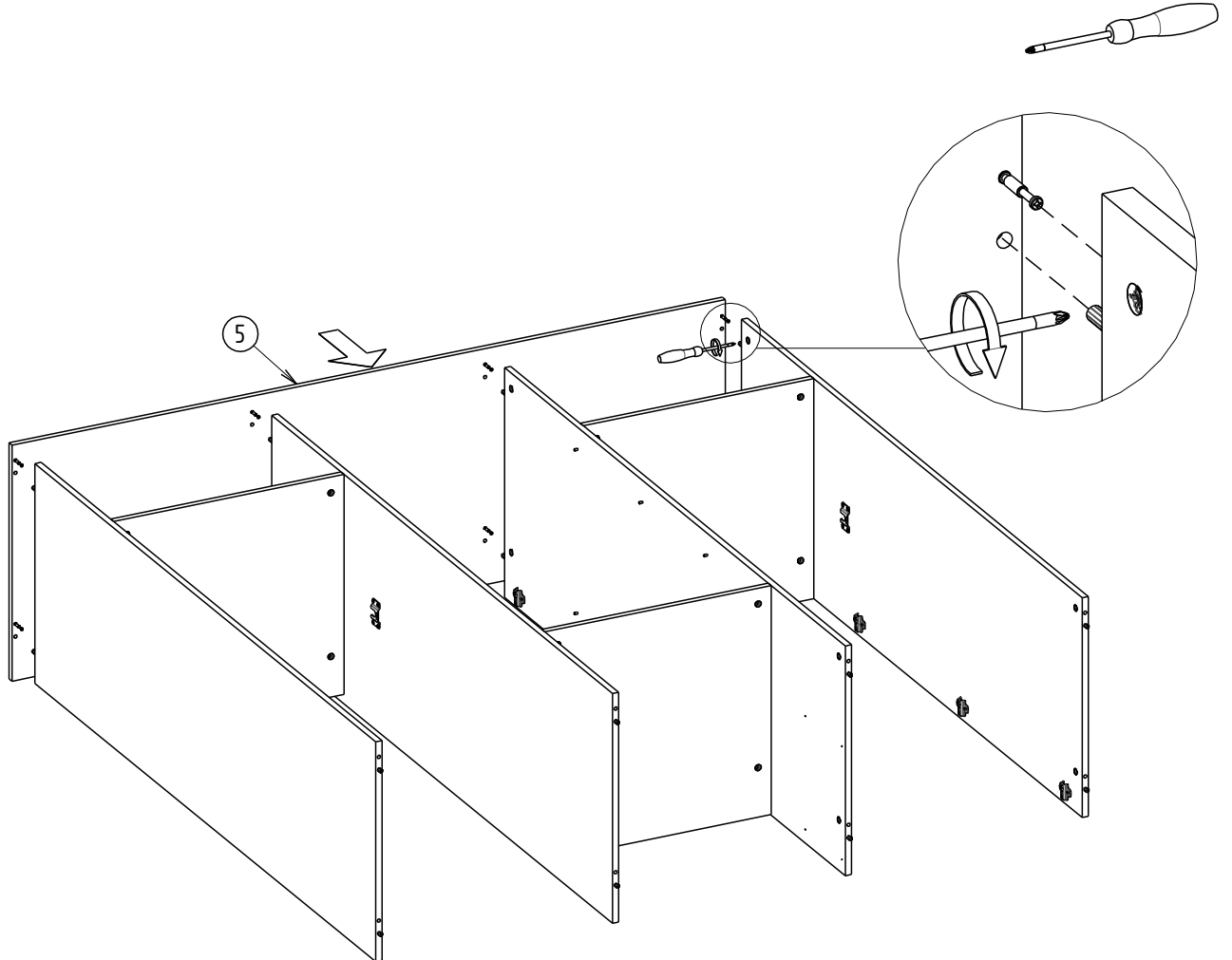

# 19

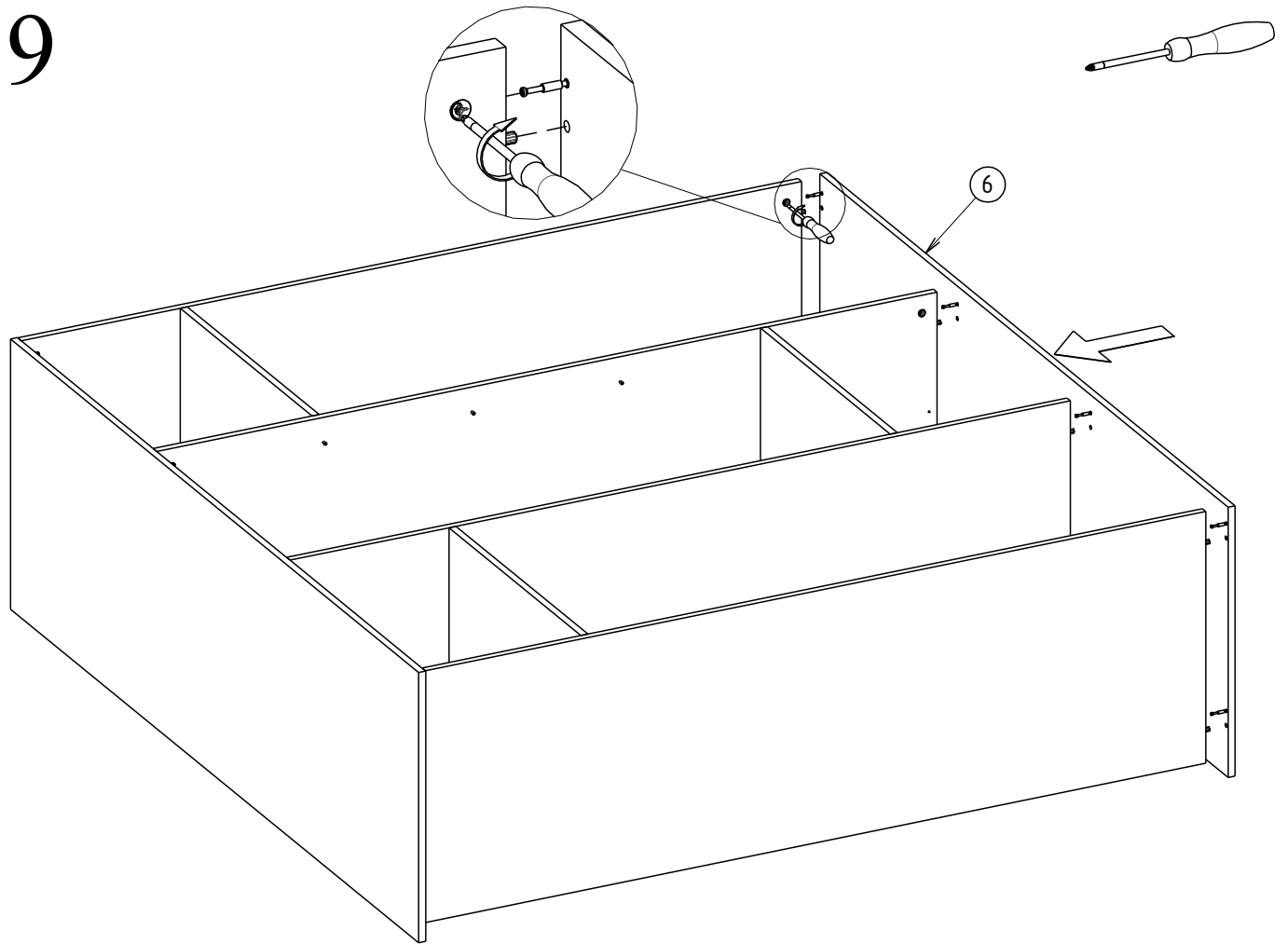

# 20

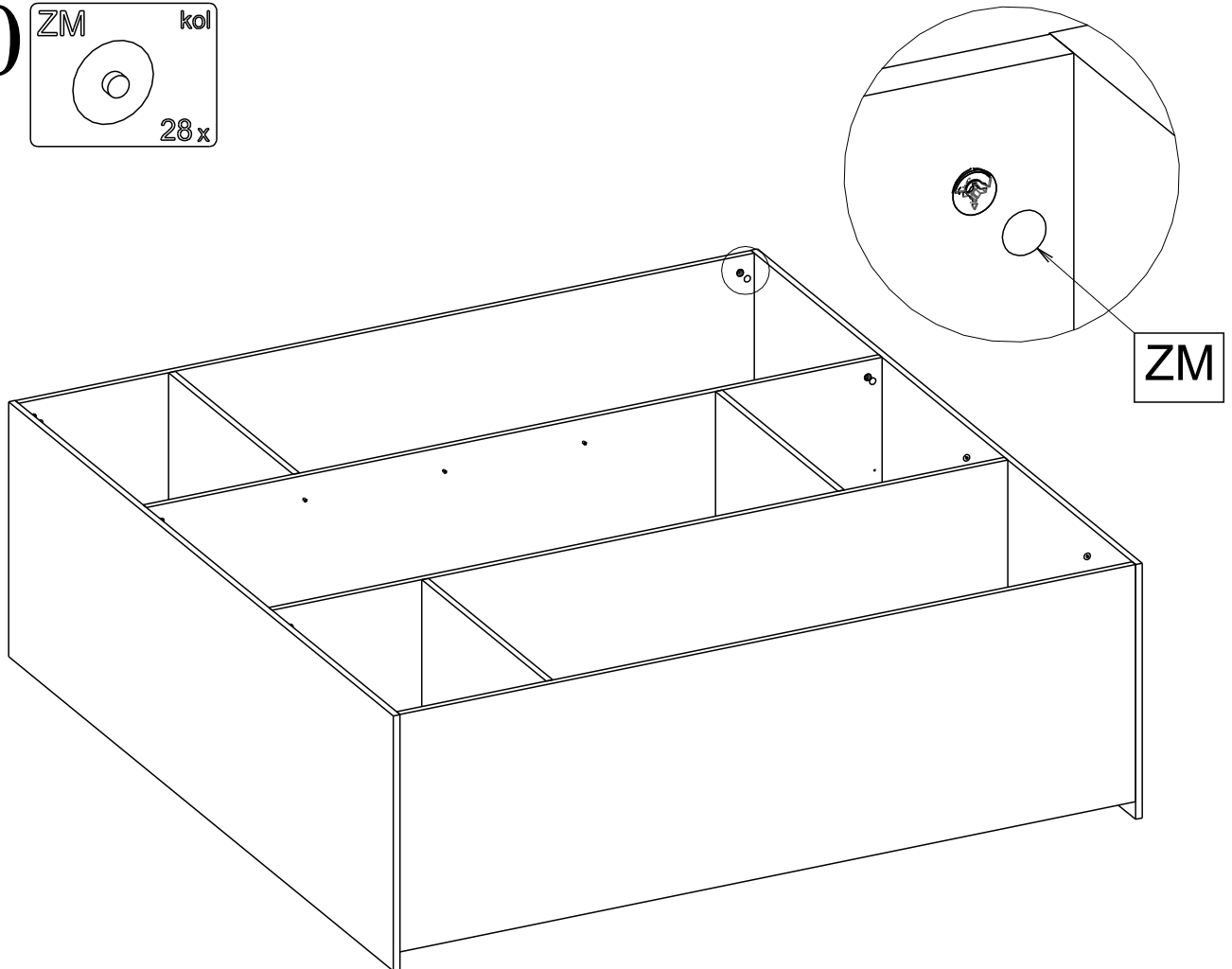
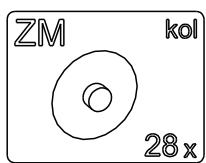

# 21

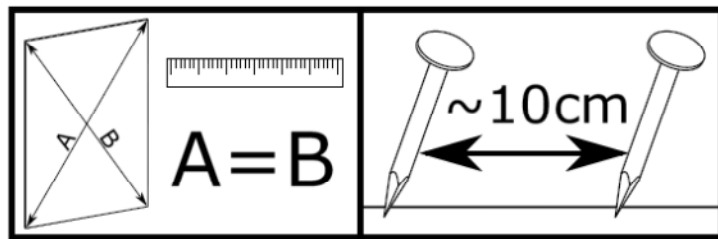
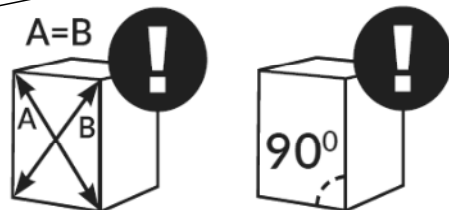
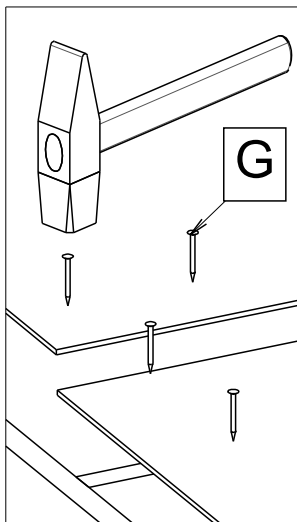
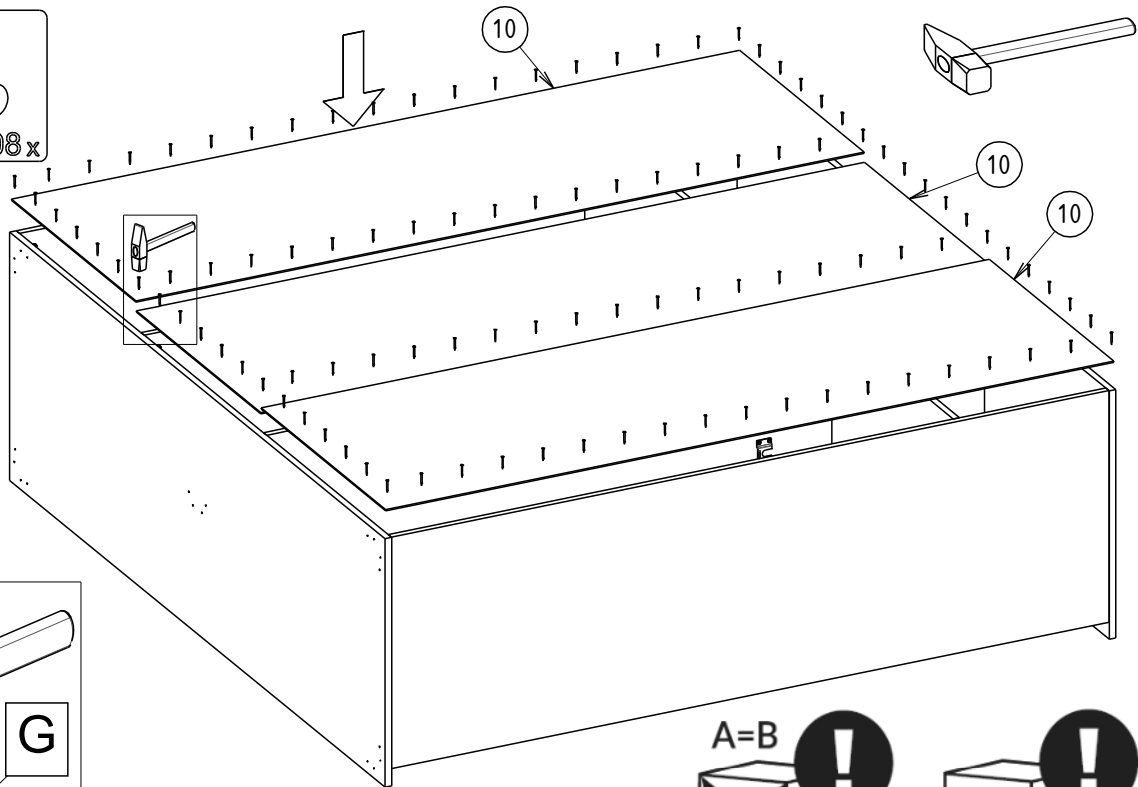
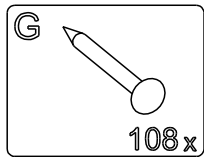

# 22

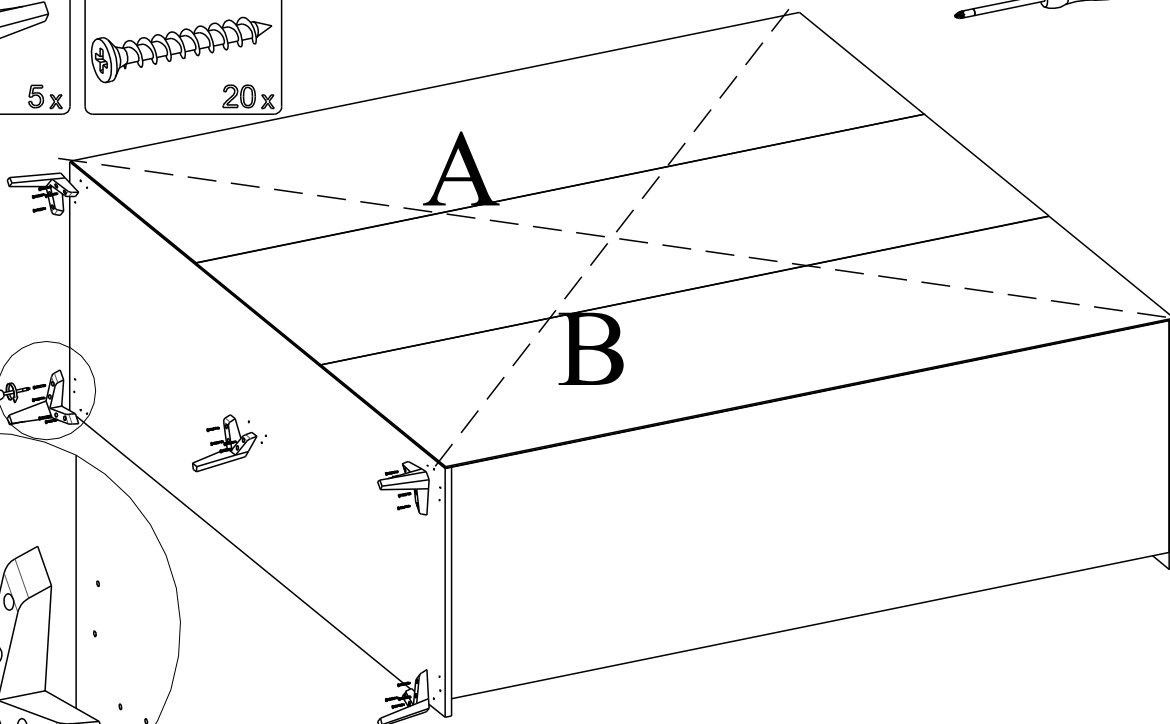
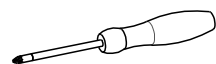
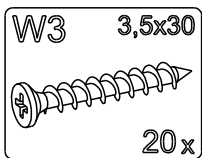
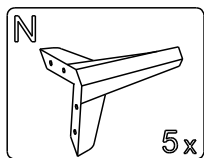

W3

N

23

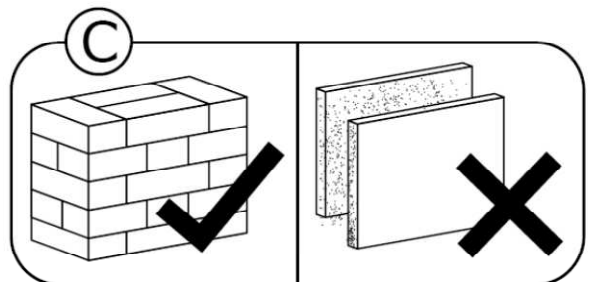
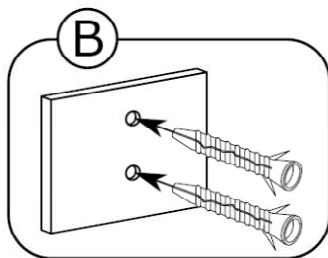
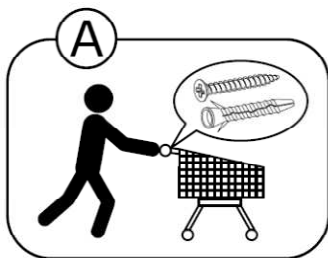
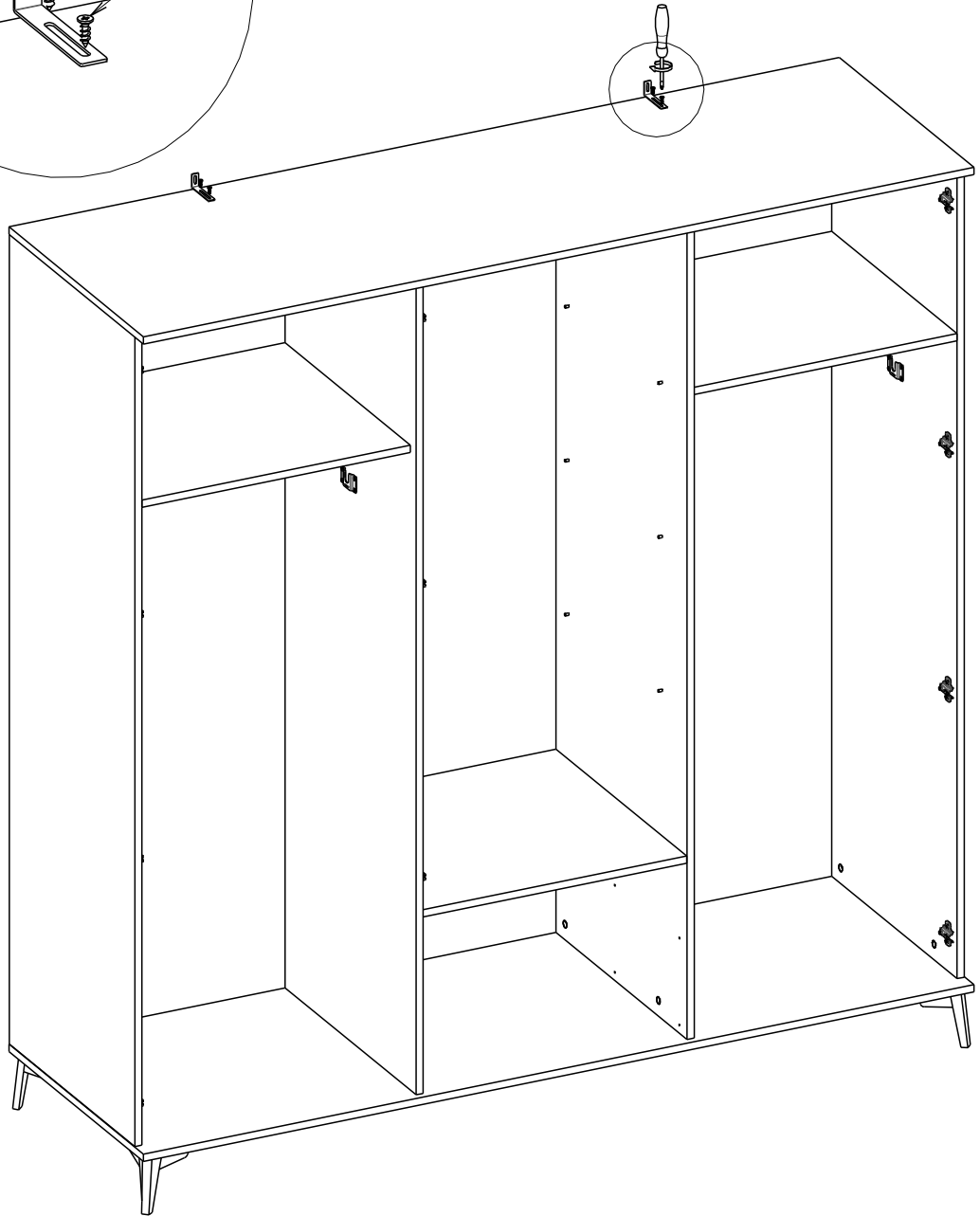
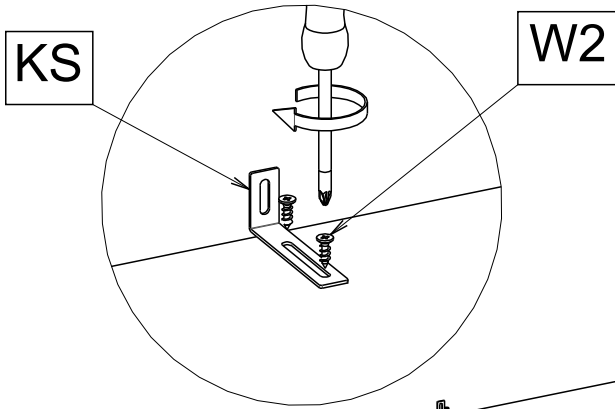
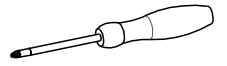
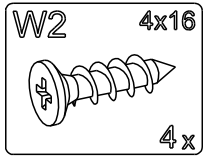
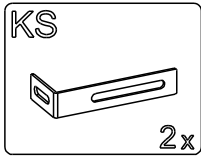

# 24

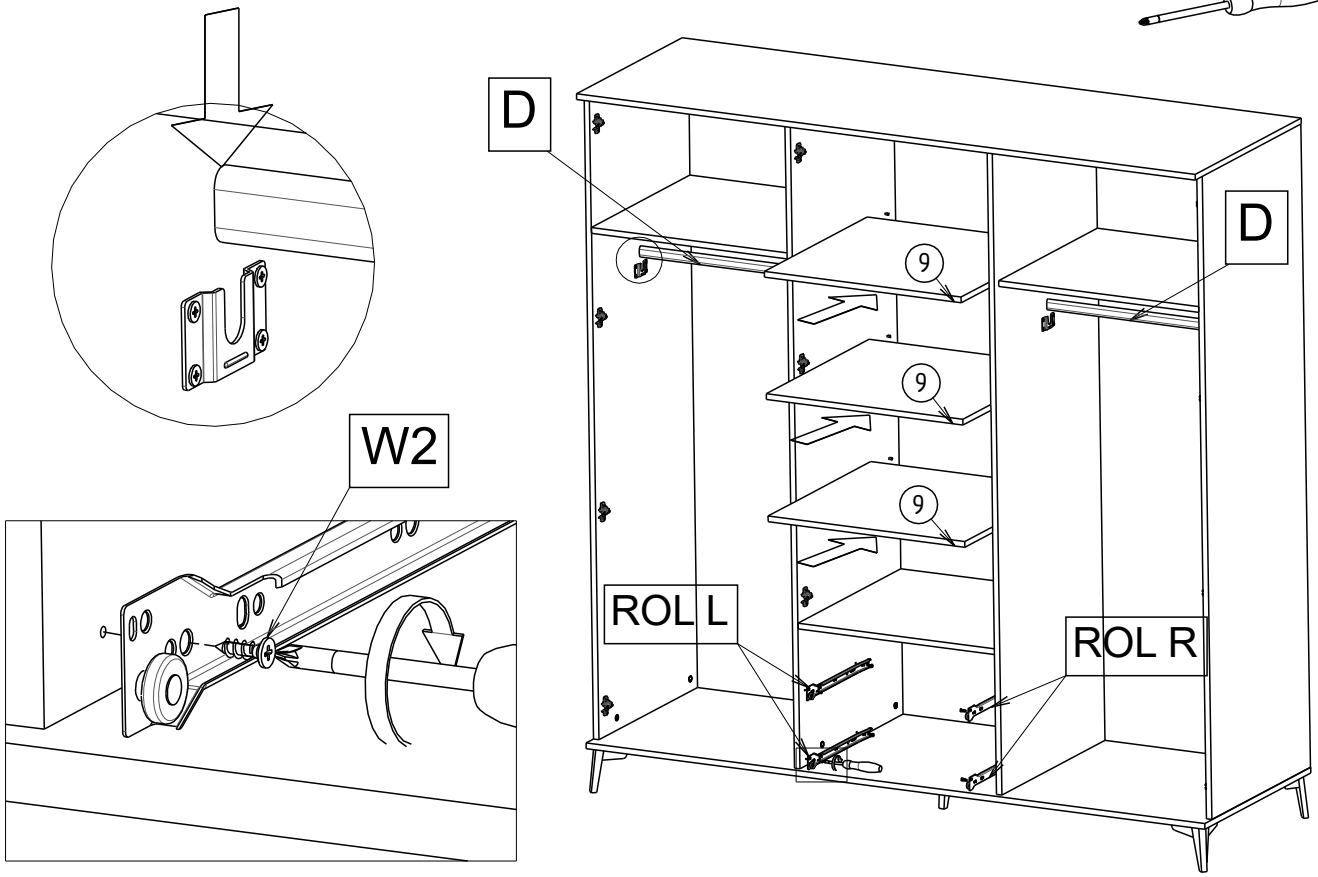
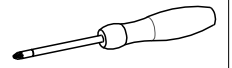
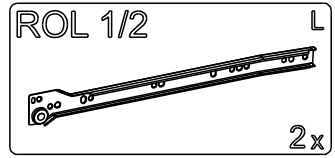
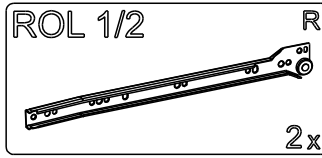
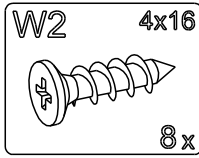
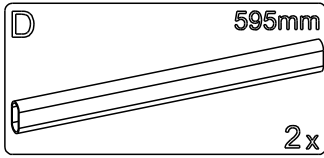

# 25

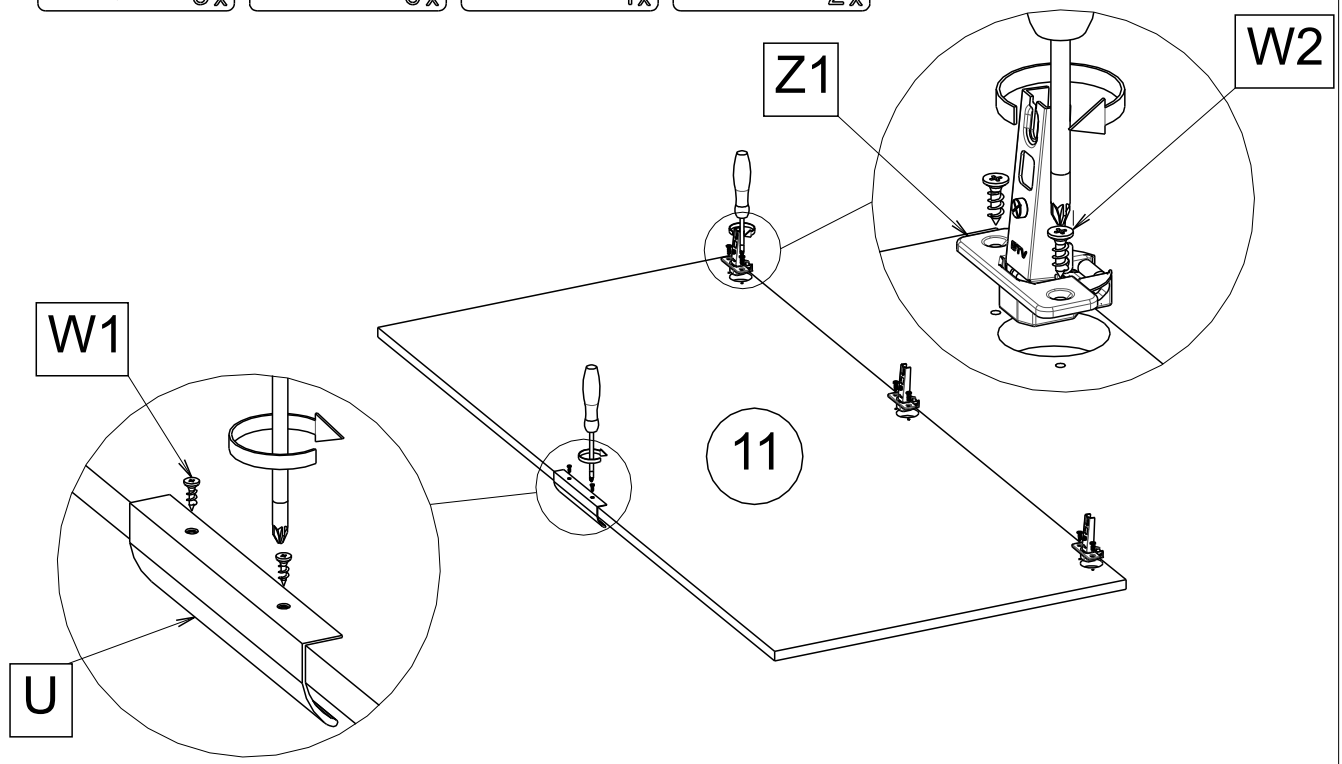
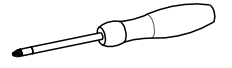
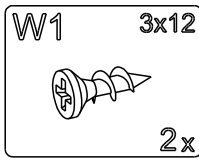
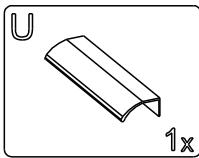
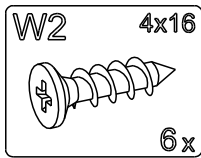
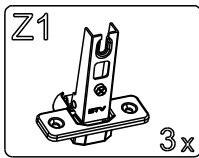

# 26

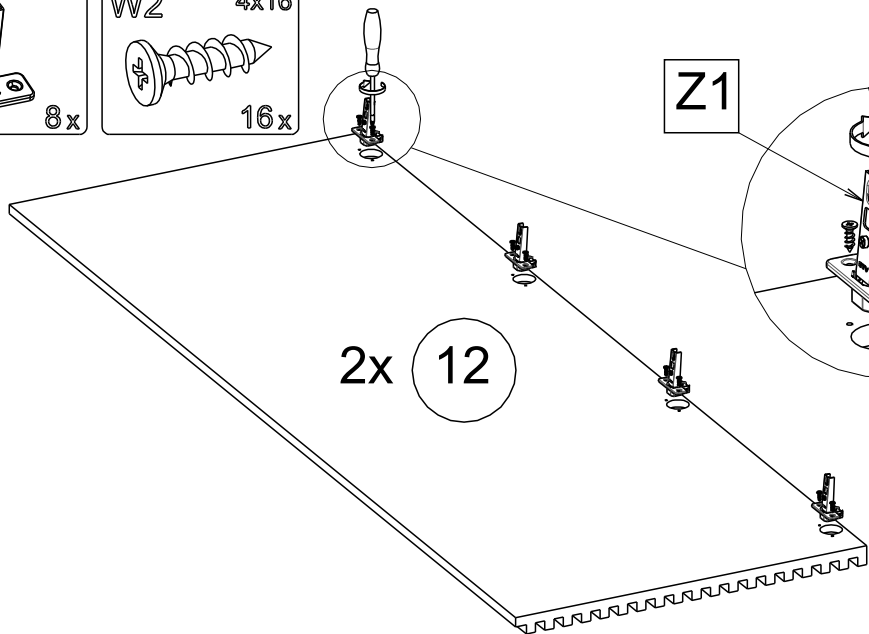
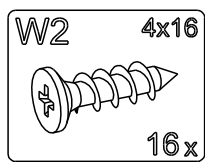
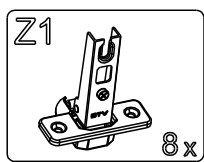

# 27

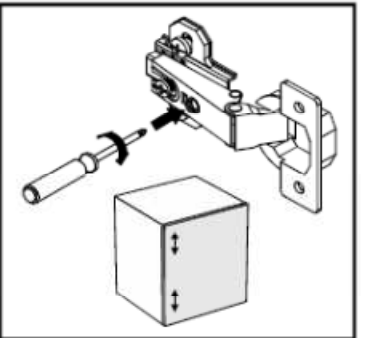
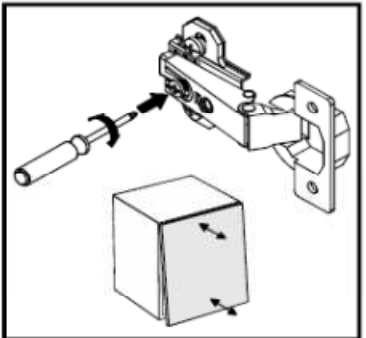
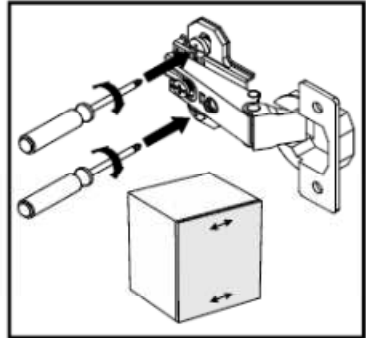
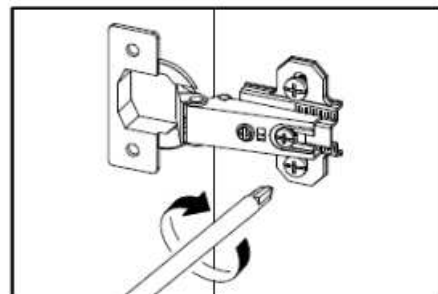
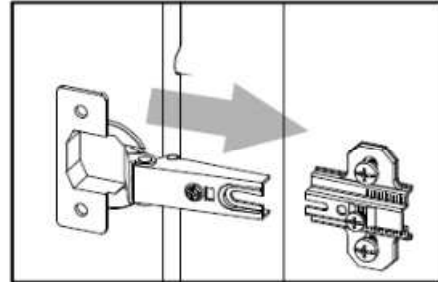
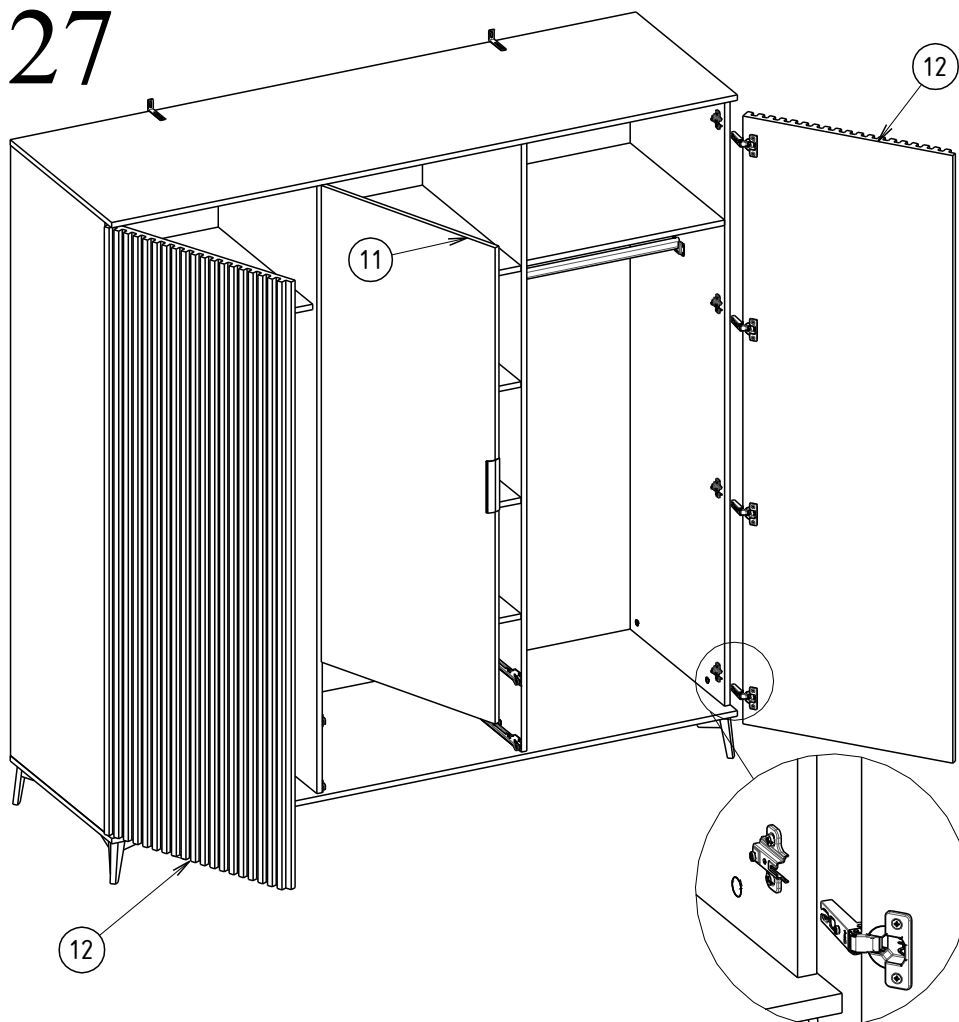



28

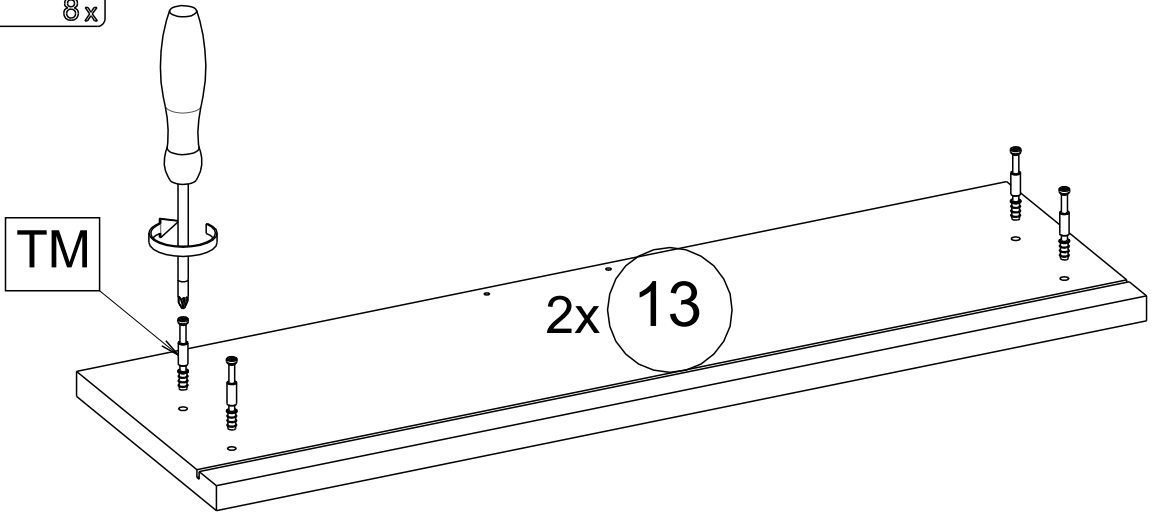
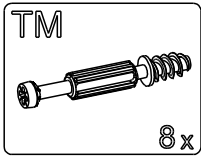

29

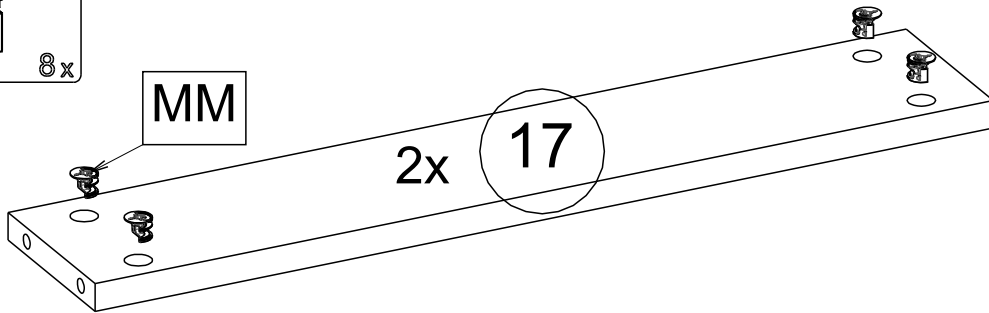
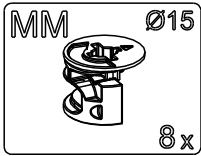

30

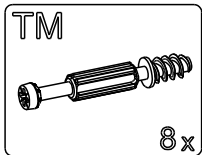
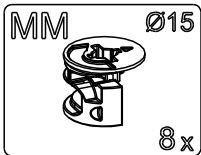

TM

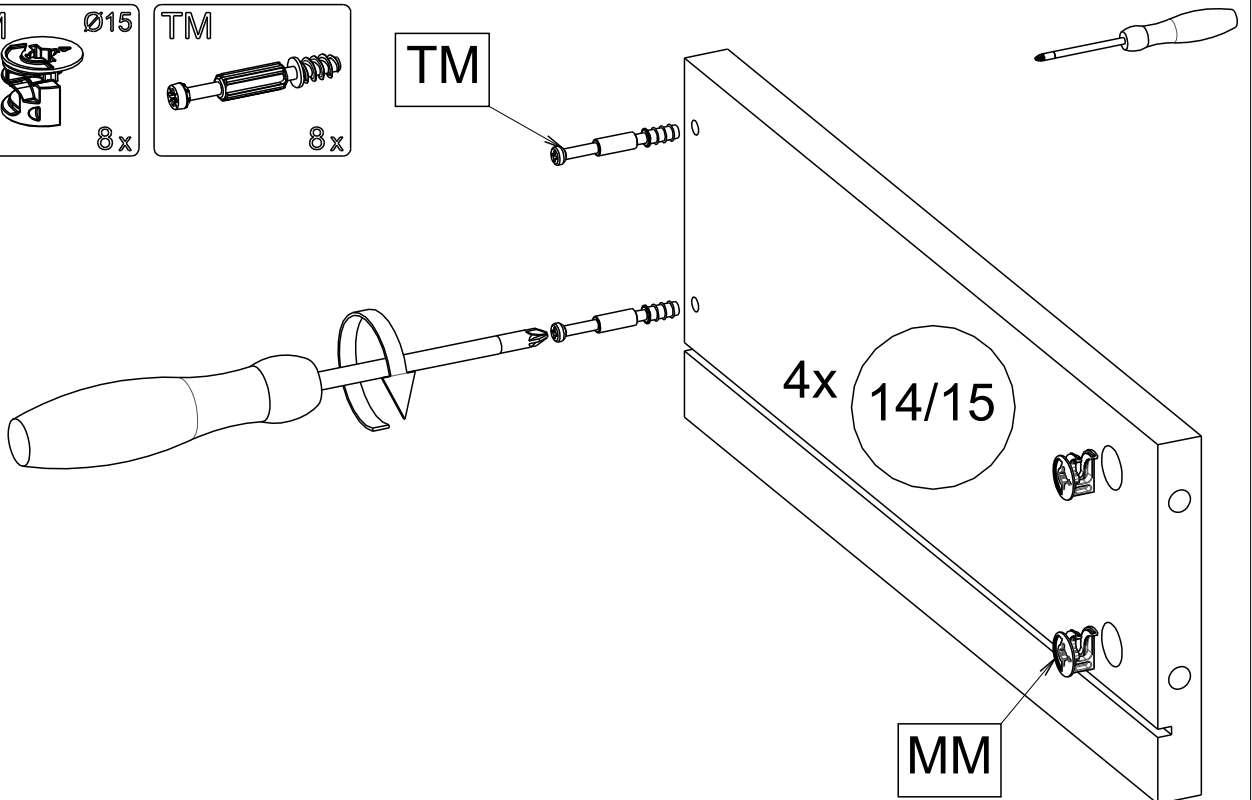



34

ROL 2/2

L+R

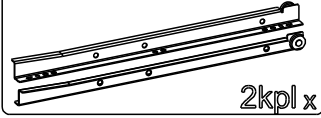

W2

4x16

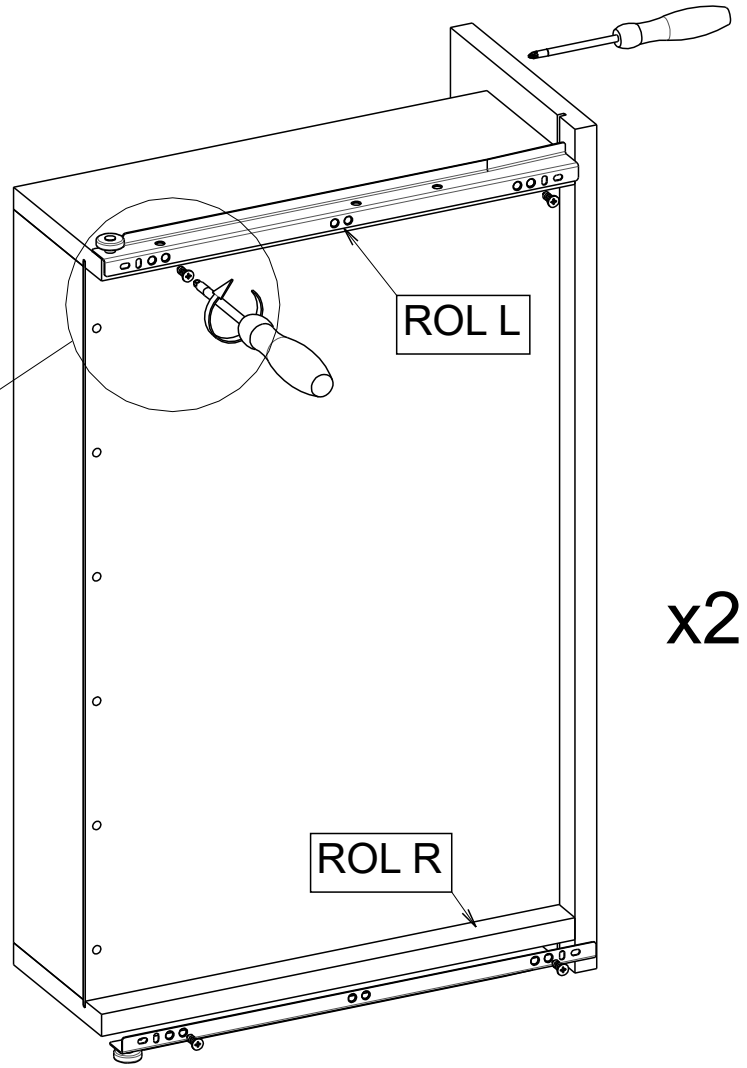
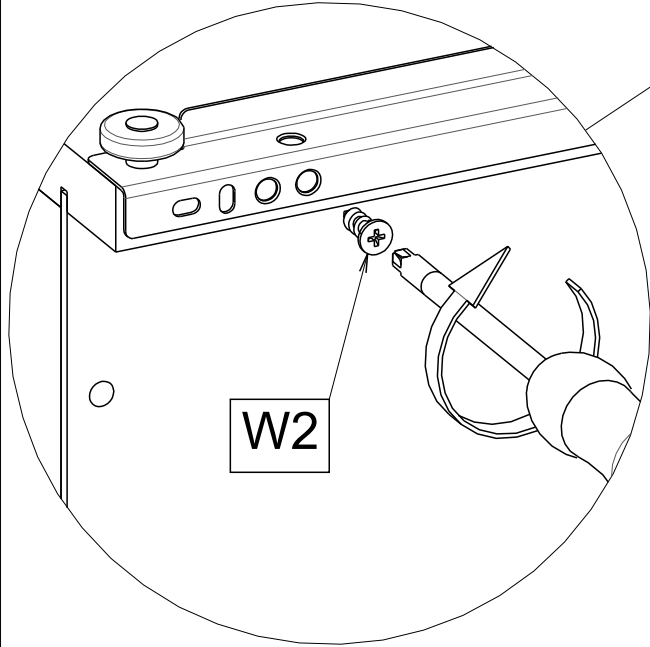
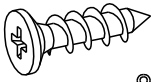

35

ZM

kol



U

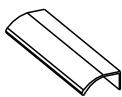

W1

3x12

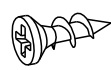

2x

