

A	B	C	D
1	GF1- 008	447	210 1/3
2	GF1- 009	447	200 1/3
3	GF1- 109	1837	414 1/3
4	GF1- 110	1837	414 1/3
5	GF1- 111	350	414 1/3
6	GF1- 306	508	414 1/3
7	GF1- 5018	1938	60 1/3
8	GF1- 5019	1938	60 1/3
9	GF1- 5020	1938	38 1/3
10	GF1- 5021	1938	38 1/3
11	GF1- 5022	1938	60 1/3
12	GF1- 5023	1938	60 1/3
13	GF1-907	1854	283 1/3
14	LH - 1820	1820	14 1/3
15	GF1- 203	602	450 2/3

A	B	C	D
16	GF1- 307	508	414 2/3
17	GF1- 309	508	400 2/3
18	GF1- 310	508	409 2/3
19	GF1- 403	101	44 2/3
20	GF1- 405	453	56 2/3
21	GF1- 551	400	120 2/3
22	GF1- 552	400	120 2/3
23	GF1- 555	400	150 2/3
24	GF1- 556	400	150 2/3
25	GF1- 558	395	120 2/3
26	GF1- 559	395	150 2/3
27	GF1- 906	410	399 2/3
28	GF1-011	1404	447 3/3

28x φ15x12mm #16 r1	28x 20/9 r16	6x φ3,5x15 mm p51	22x φ16 s2	1x z1	2x φ7x50 mm e1	8x φ5x50 mm e32	16x s1
12x φ6x13 mm e3	33x φ8x30 mm f1	4x k1	6x d36	60x l1	13x φ3,5x16 mm p38	3x a98	3x b98
3x c415	3x M4x22 mm j30	4x φ8x50 mm f6	4x 400 w208/1	4x 400 w208/2	24x φ7x28 mm e22	8x φ5x17 mm d1	
12x Ø3,5x12 mm p140	1x n26v1						1x 1x

1 §2

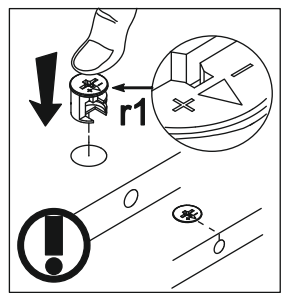
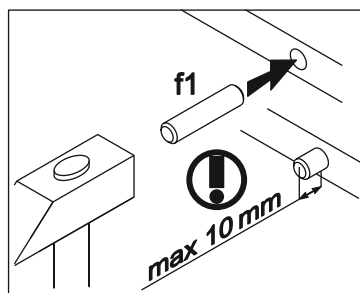
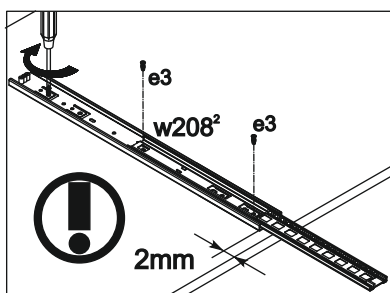
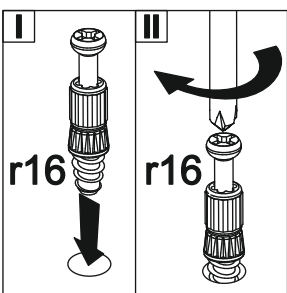
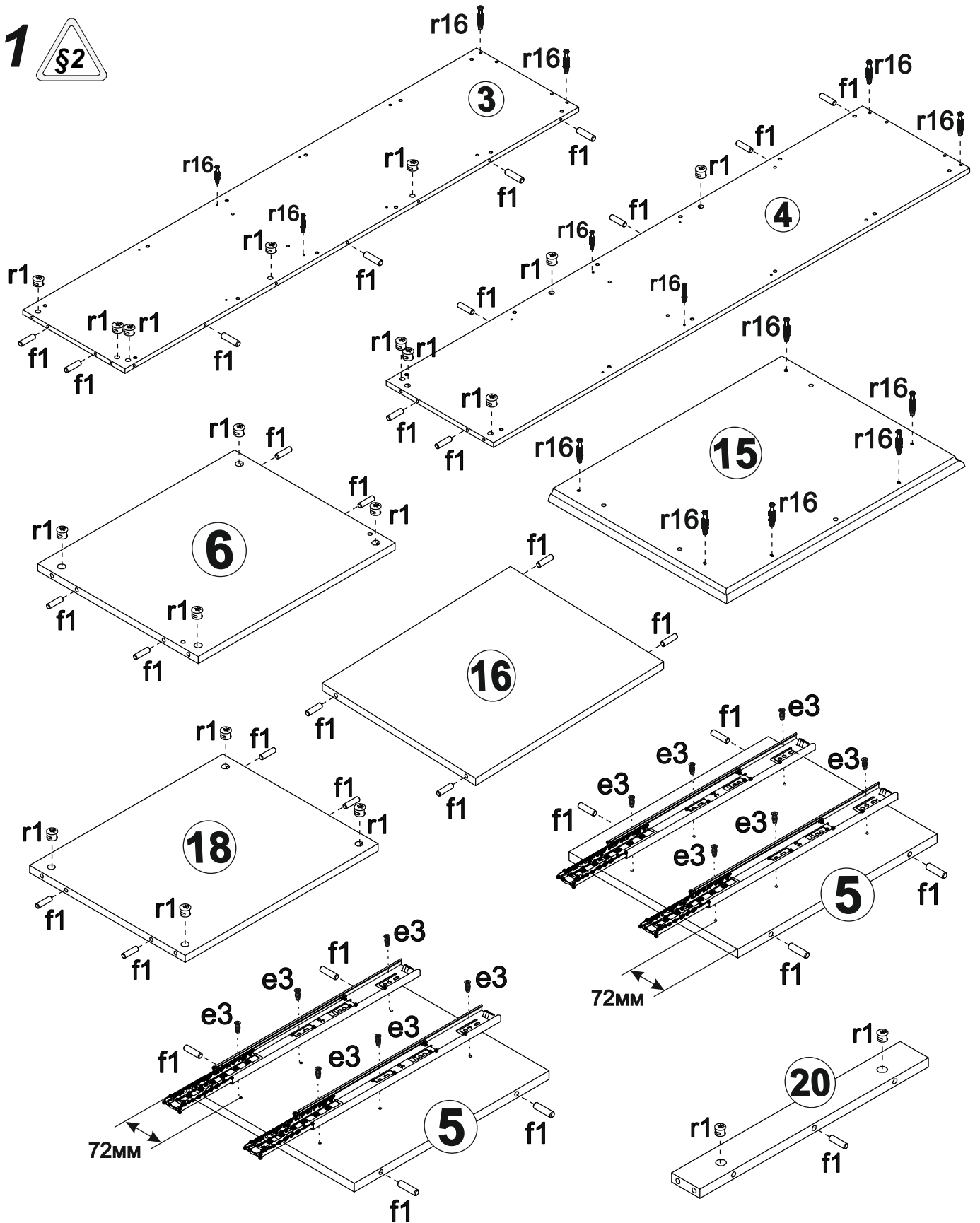

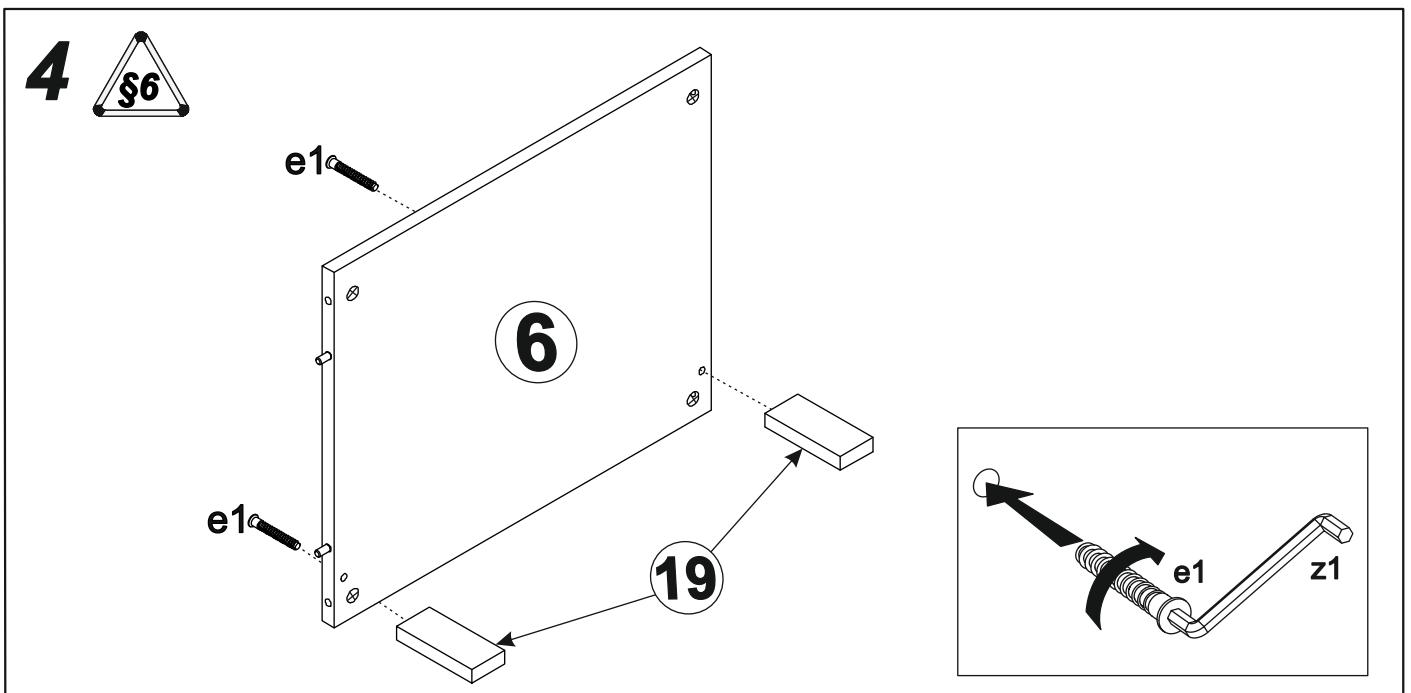
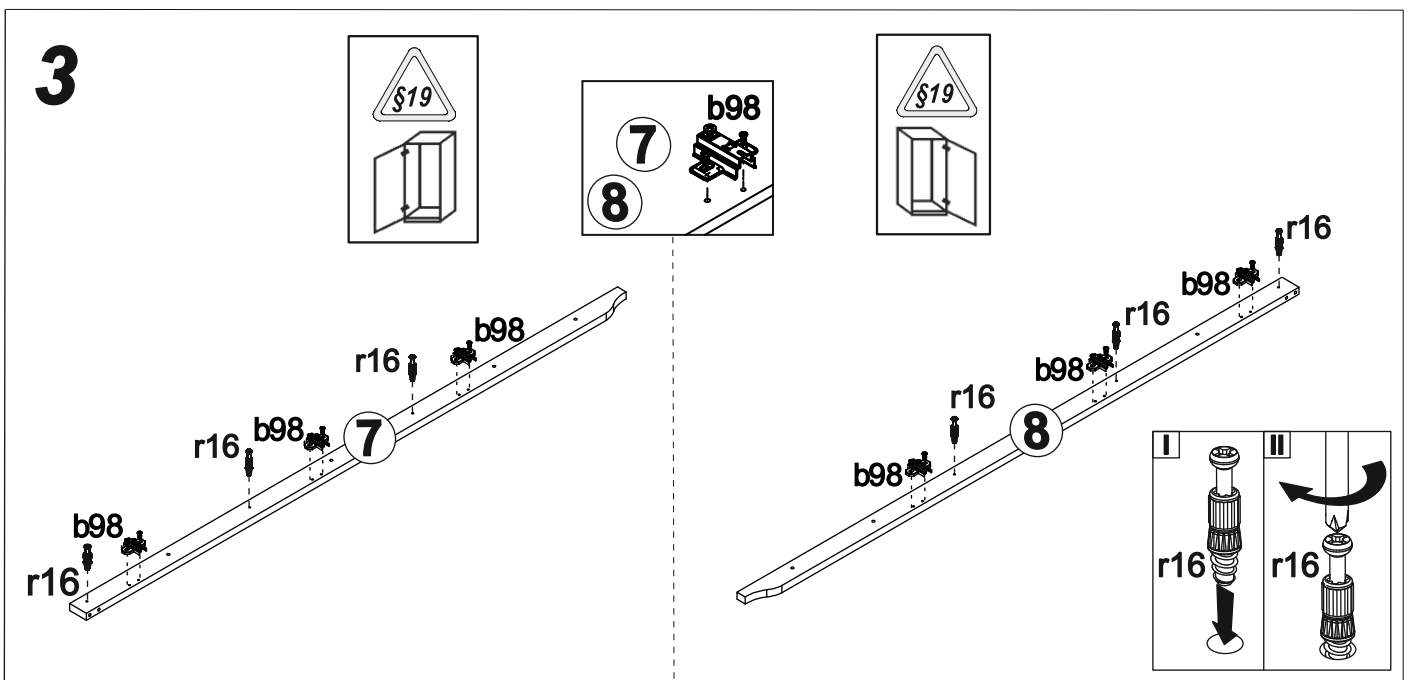
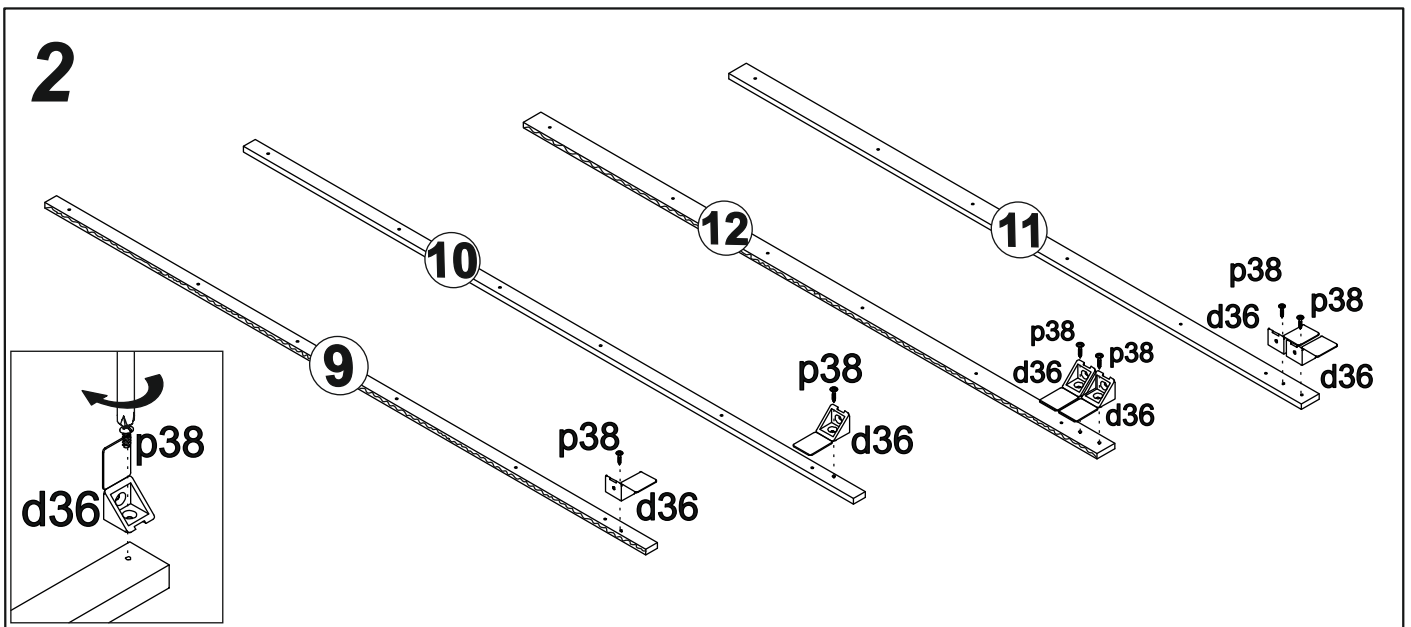

5

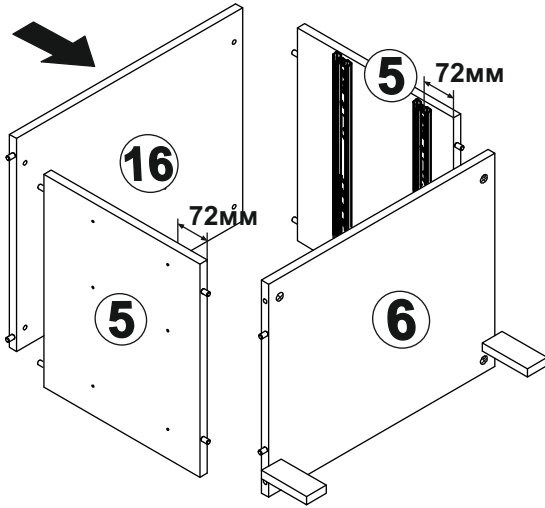

6

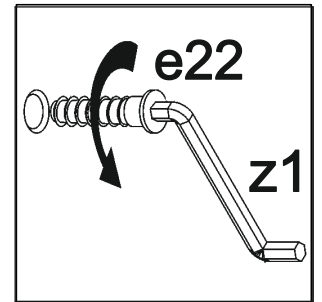
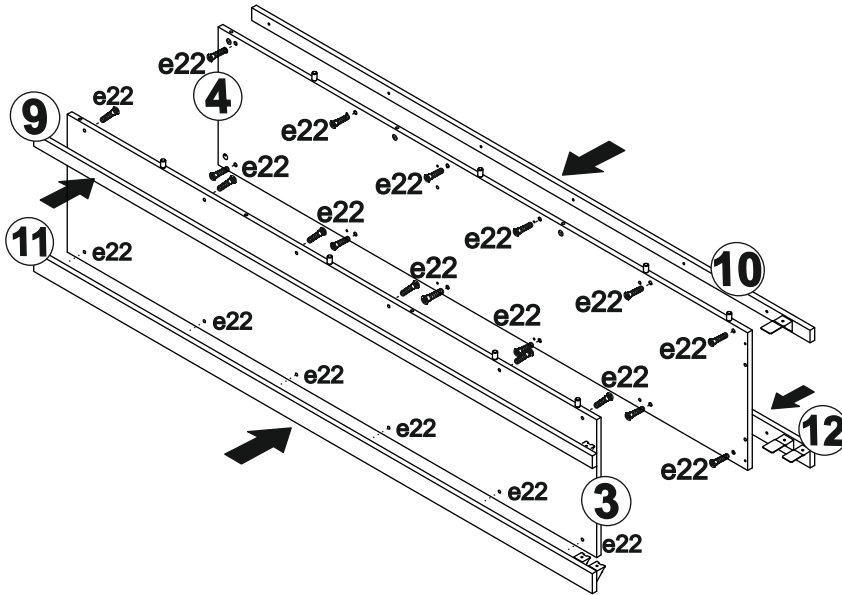

7

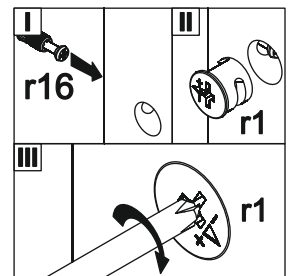
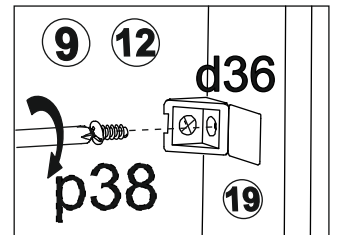
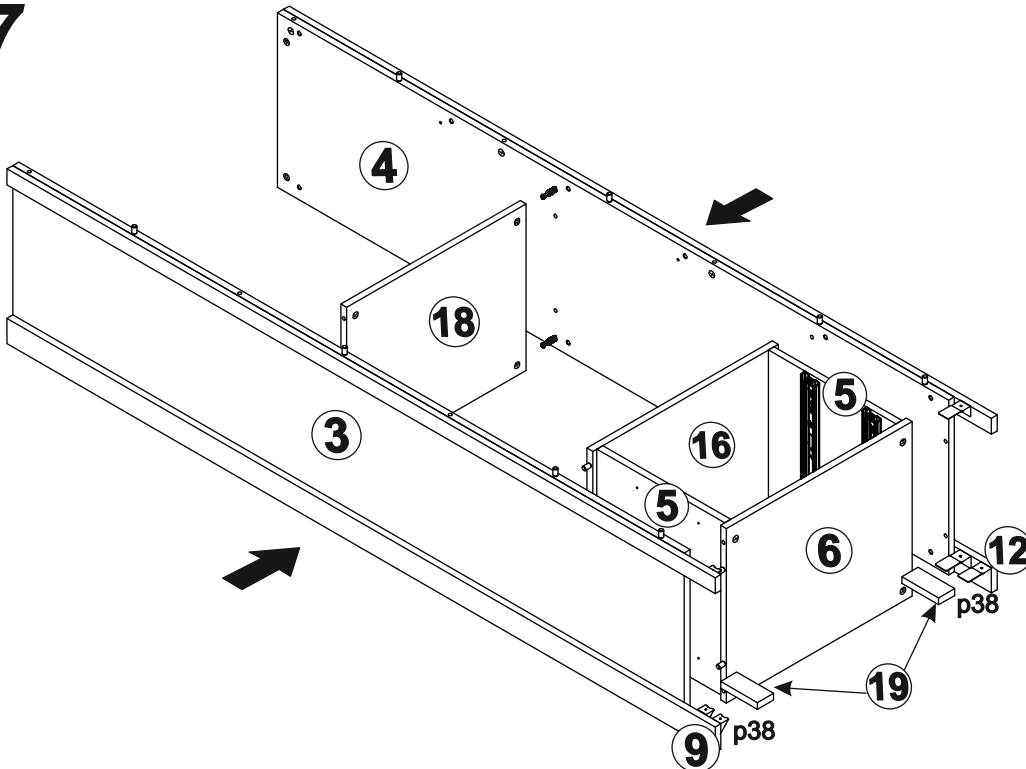

8

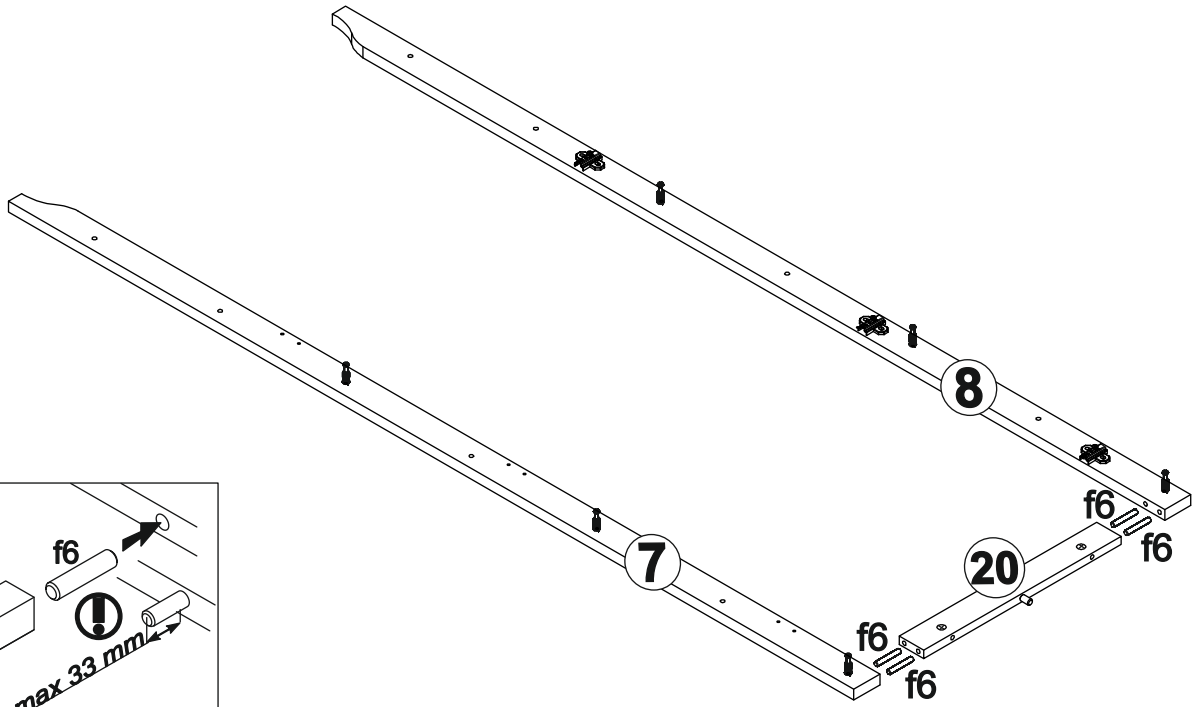

9

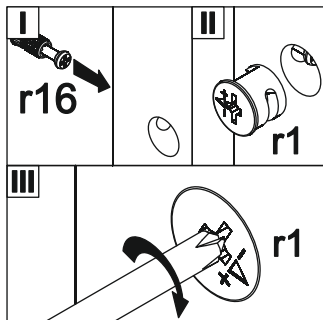
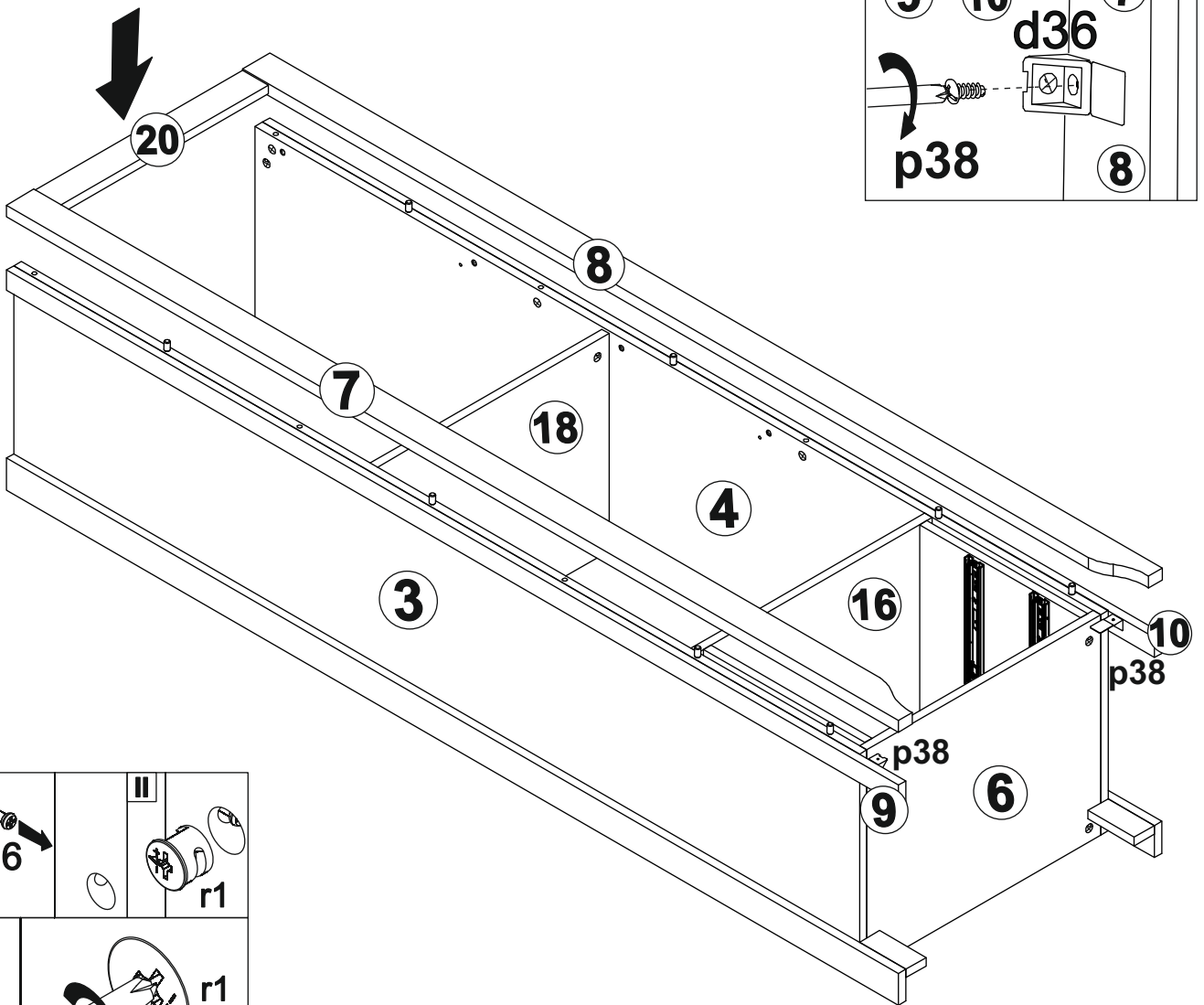

10

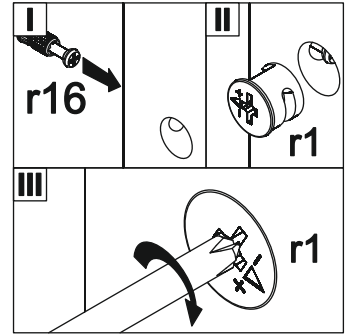
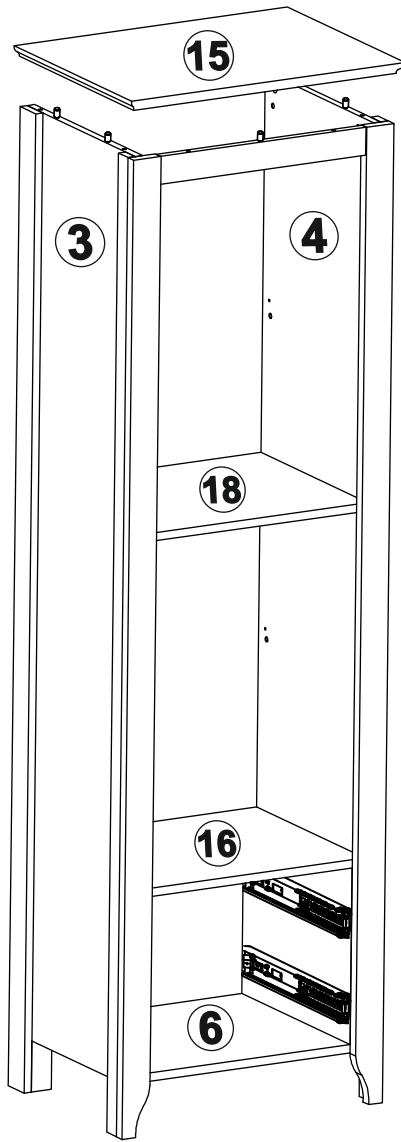

11

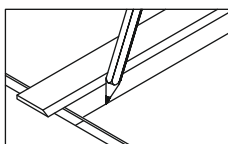
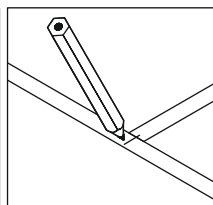
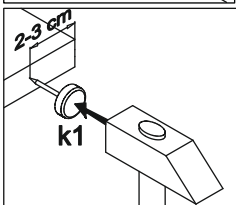
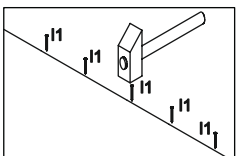
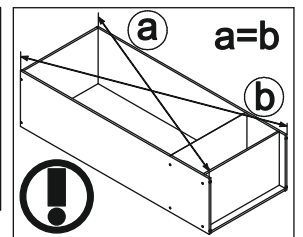
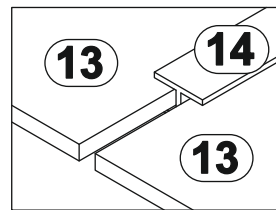
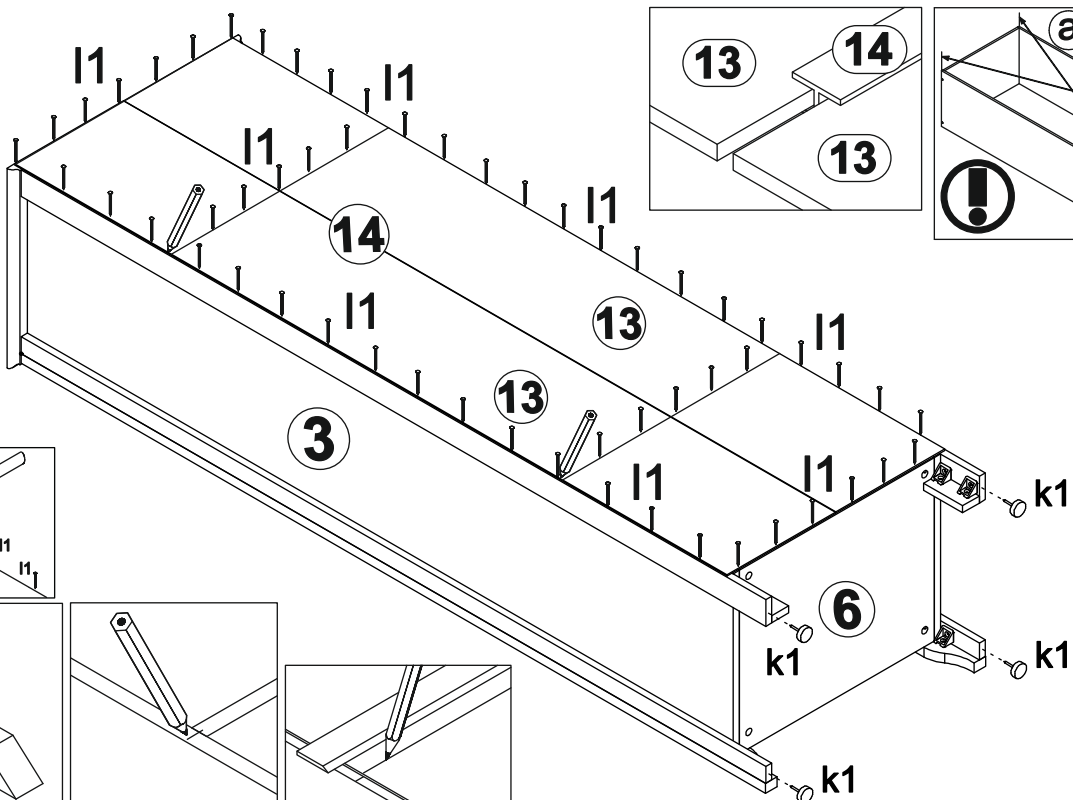

12

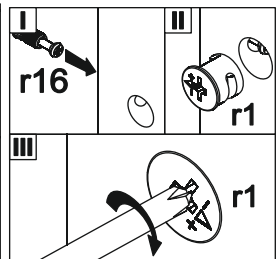
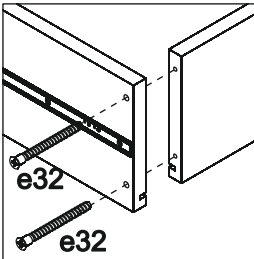
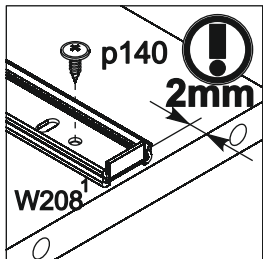
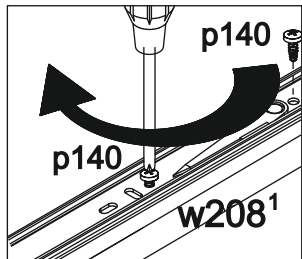
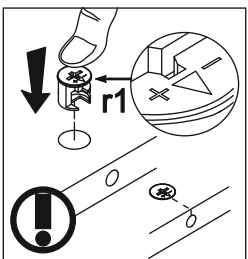
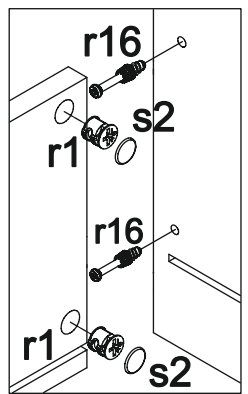
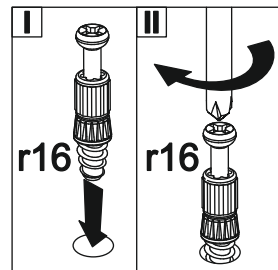
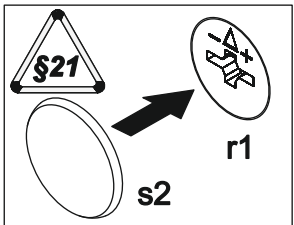
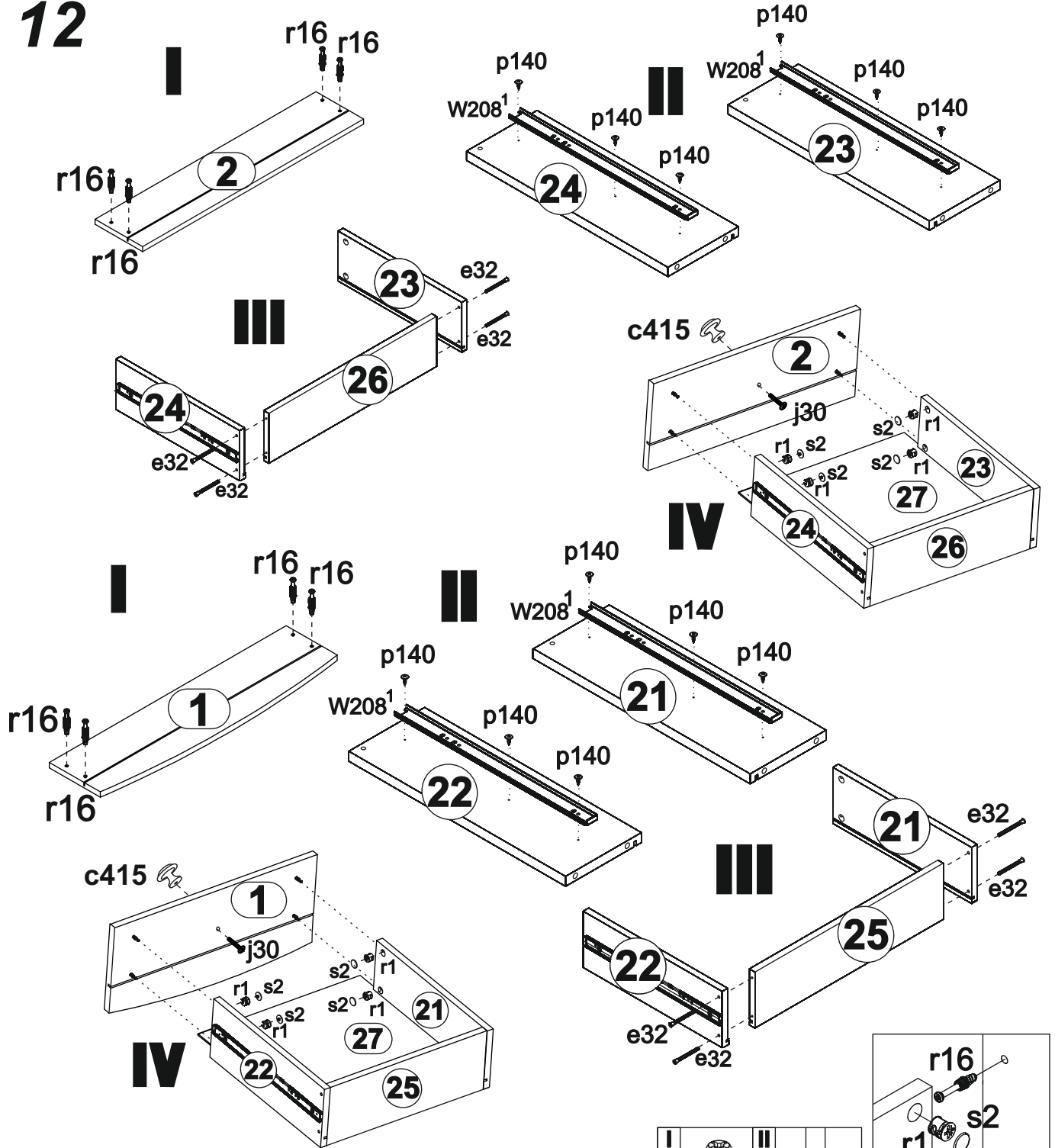

13

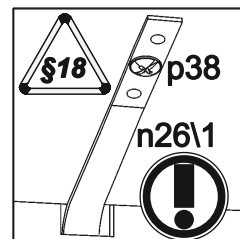
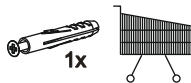

c415

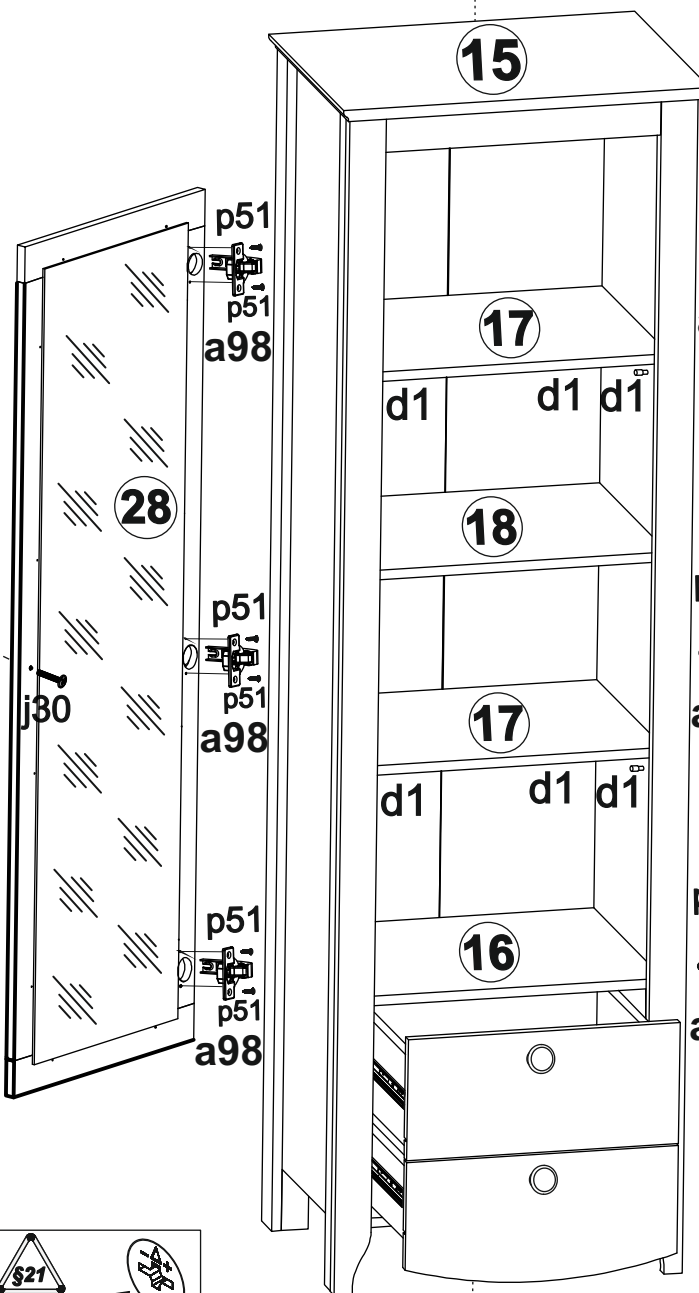

c415

