

Julia 2,6

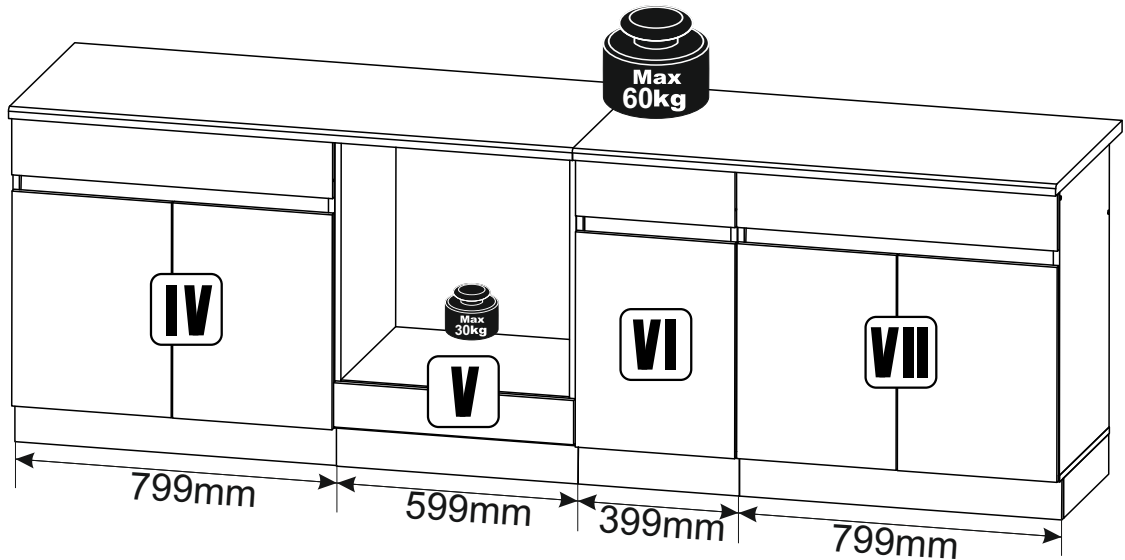

| | | | | | | |
|------------------------------|---------------------------|---------------------------|--------------------------------------|-----------------------------|----------------------------|----------------------------|
| 22x k0 a44 | 22x b19 | 9x φ15x12mm #16 r1 | 9x 20/9 r16 | 8x φ16 s2 | 16x s1 | 12x φ6x13 mm e3 |
| 72x φ8x30 mm f1 | 32x φ5x17 mm d1 | 10x φ5x50 mm e32 | 66x φ7x50 mm e1 | 1x z1 | 184x l1 | 16x φ3,5x13 mm p5 |
| 48x φ3,5x15 mm p51 | 26x φ3,5x13 mm p1 | 8x φ3x12 mm p54 | 2x 400 mm w5\CL | 2x 400 mm w5\CR | 2x 400 mm w5\DL | 2x 400 mm w5\DR |
| 8x n122\1 | 24x φ4x30 mm p21 | 2x a210 | 2x b105 | 72x φ3,5x16 mm p38 | 8x ø5 s4 | 2x φ7x28 mm e22 |
| 1x m5 ¹ L | 1x m5 ² | 8x n10 | 24x M4x12 mm j45 ¹ | 12x j45 ² | 12x k7 ⁴ | 16x k7 ² |
| 8x 81x21x15/1,5mm n14 | | | | | | 16x k7 ¹ |

| | | | | |
|------------------------|-------------------------------|-------------------------------|-------------------------------|-------------------------------|
| 6x φ3x12 mm p54 | 2x z100/1 ¹ | 2x z100/1 ² | 2x z100/1 ³ | 2x z100/1 ⁴ |
|------------------------|-------------------------------|-------------------------------|-------------------------------|-------------------------------|

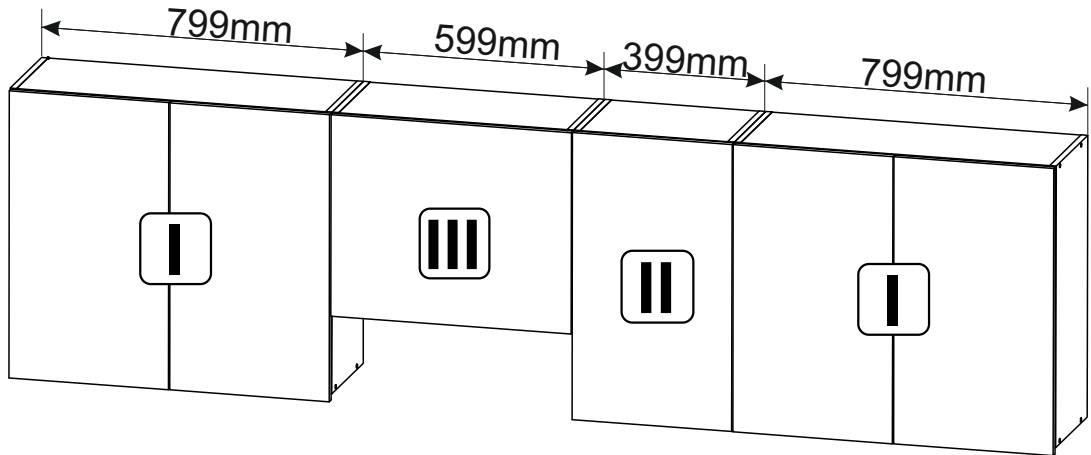
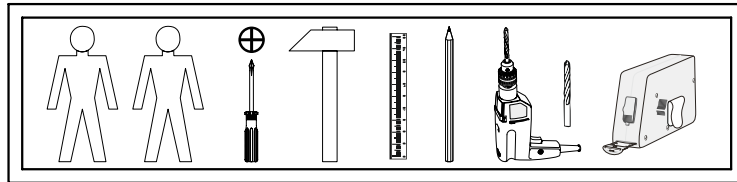
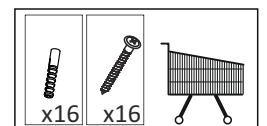

I

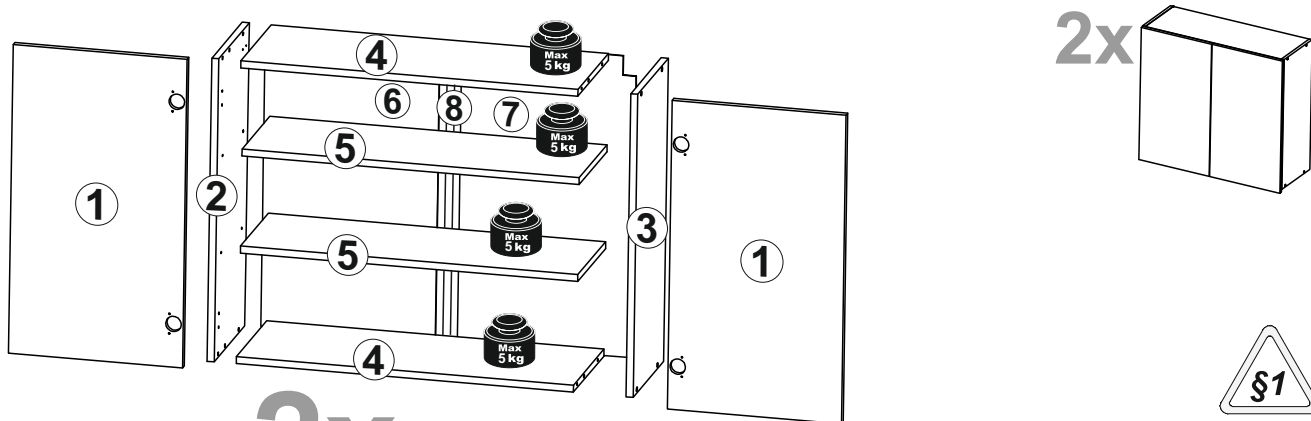

2x



| A | B | C | D | |
|---|----------|-----|-----|-----|
| 1 | DI1 -005 | 713 | 396 | 7/8 |
| 2 | DI1 -103 | 700 | 285 | 2/8 |
| 3 | DI1 -104 | 700 | 285 | 2/8 |
| 4 | DI1 -305 | 767 | 285 | 4/8 |
| 5 | DI1 -306 | 767 | 260 | 4/8 |
| 6 | DI1 -906 | 695 | 397 | 3/8 |
| 7 | DI1 -907 | 695 | 397 | 3/8 |
| 8 | LH -666 | 666 | 14 | 3/8 |

1



- 8x $\phi 8 \times 30$ mm f1
- 8x b19
- 8x a44
- 16x $\phi 3,5 \times 15$ mm p51
- 16x $\phi 5 \times 17$ mm d1

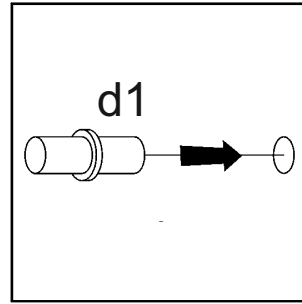
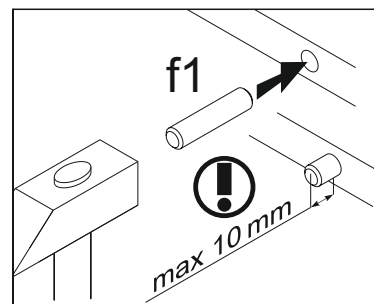
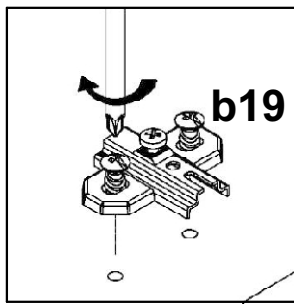
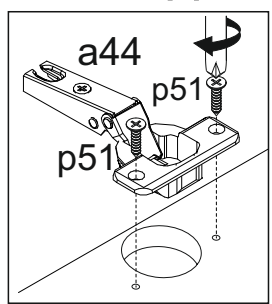
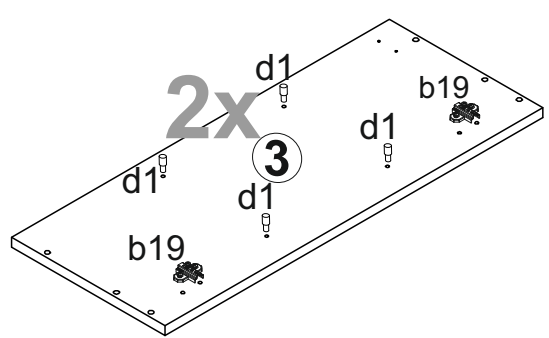
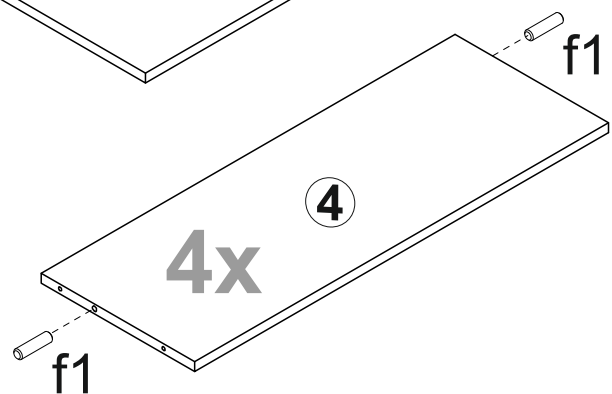
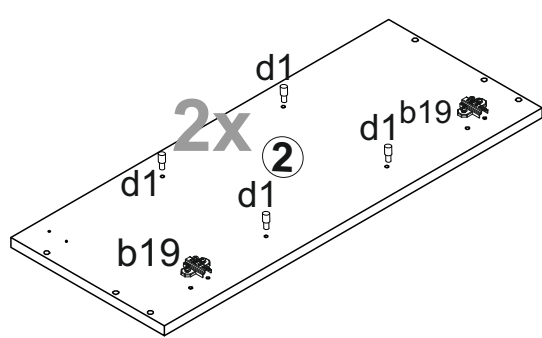
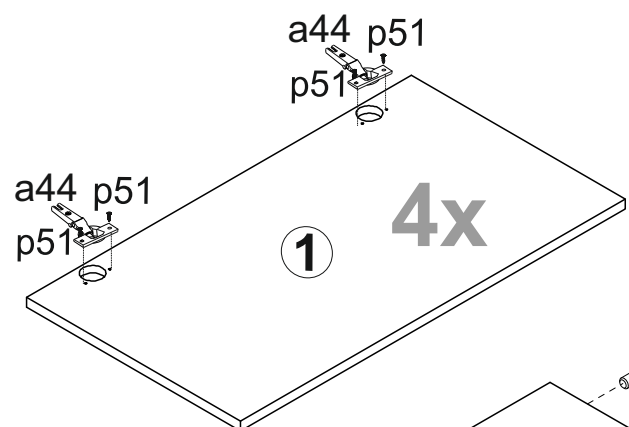

2

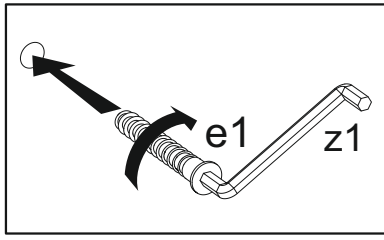

2x

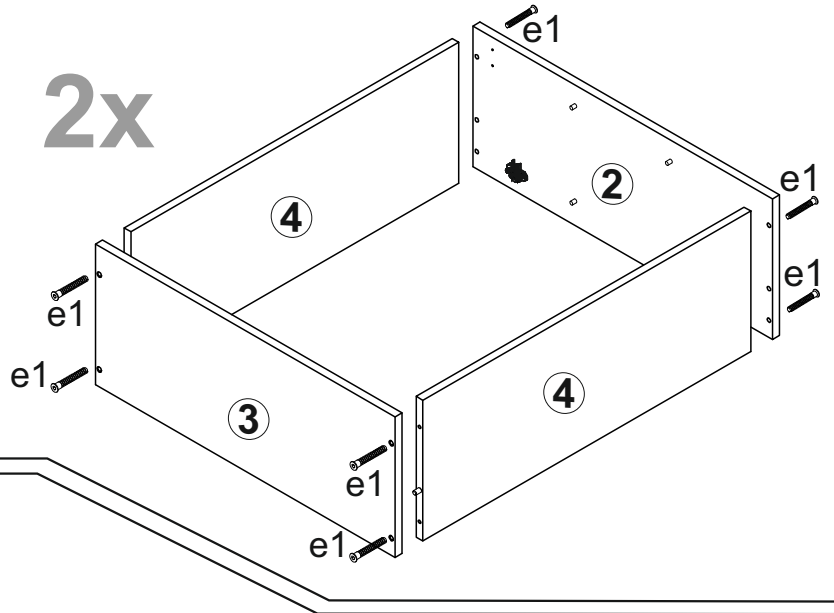

3

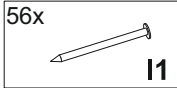

2x

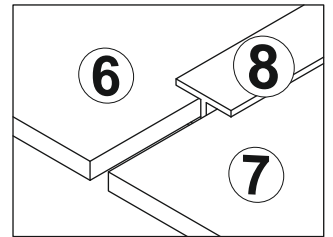
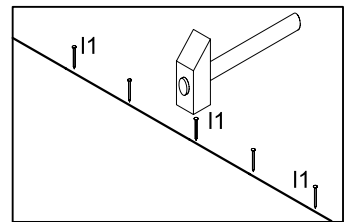
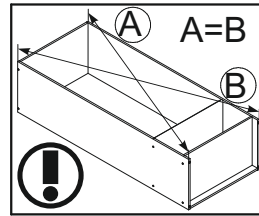
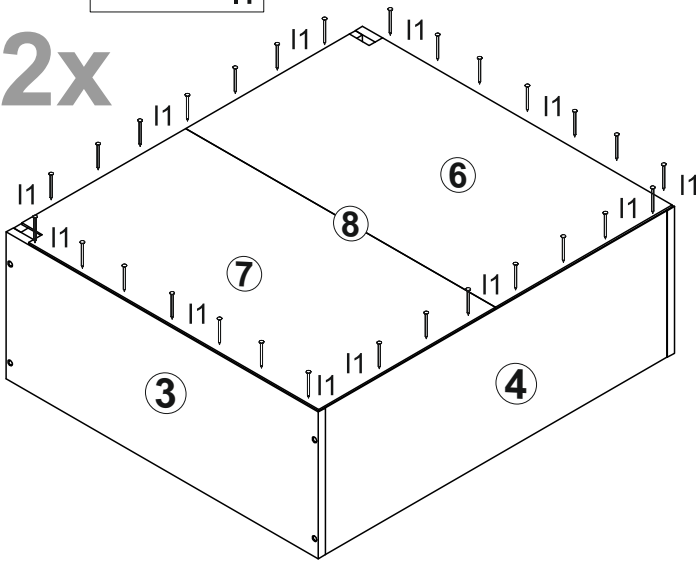

4



2x

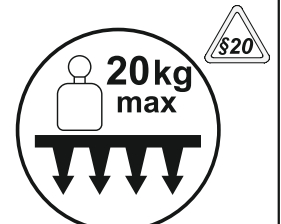
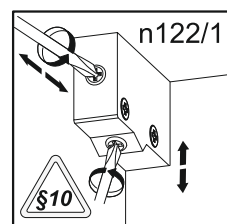
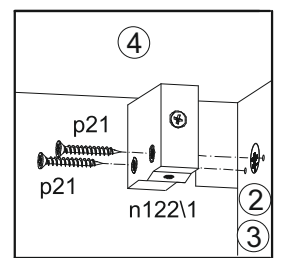
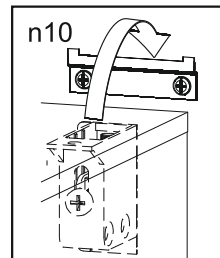
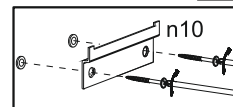
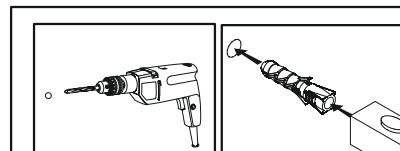
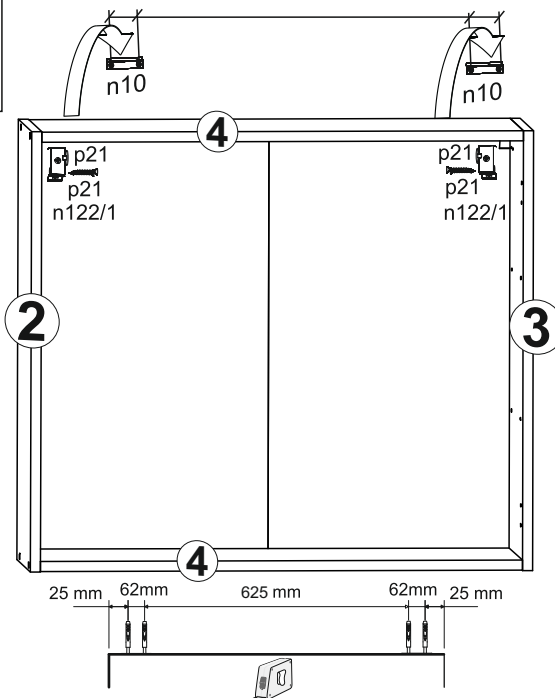
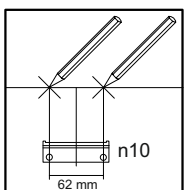
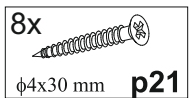
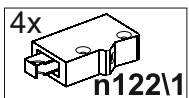
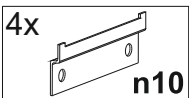
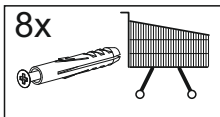

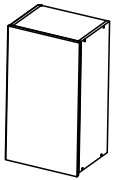
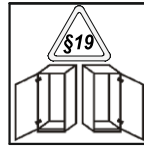
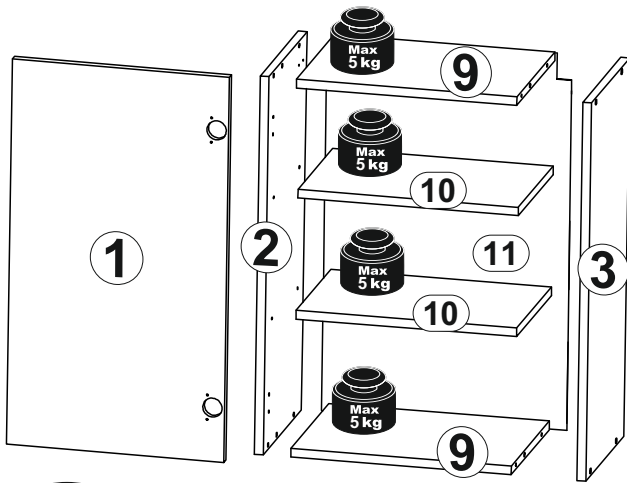

| A | B | C | | D |
|----|----------|-----|-----|-----|
| 1 | DI1 -005 | 713 | 396 | 7/8 |
| 2 | DI1 -103 | 700 | 285 | 2/8 |
| 3 | DI1 -104 | 700 | 285 | 2/8 |
| 9 | DI1 -302 | 367 | 285 | 3/8 |
| 10 | DI1 -303 | 367 | 260 | 3/8 |
| 11 | DI1 -905 | 695 | 394 | 3/8 |

5

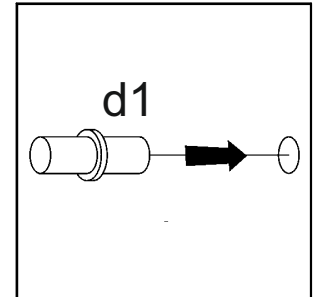
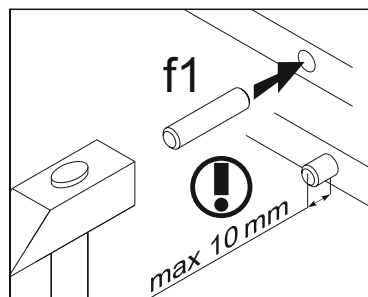
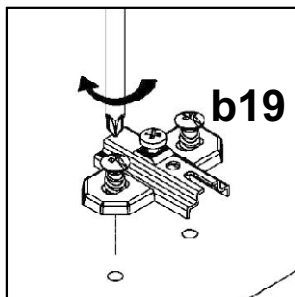
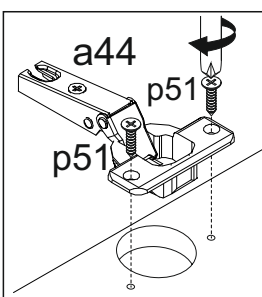
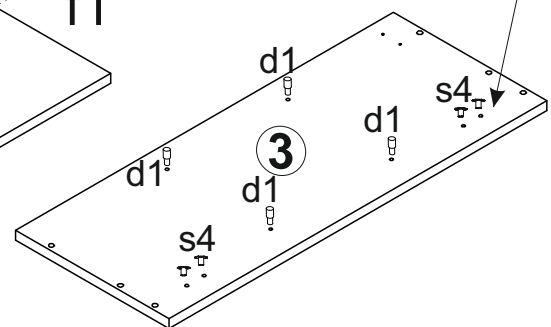
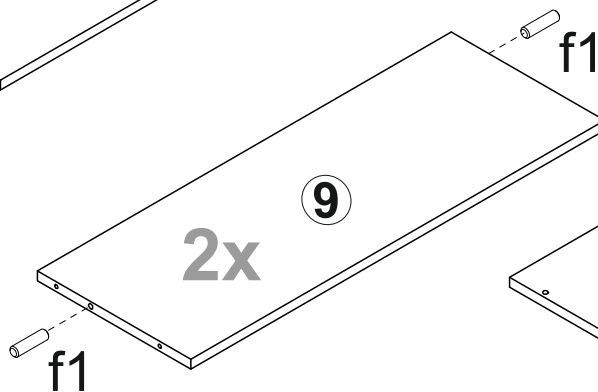
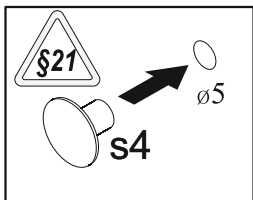
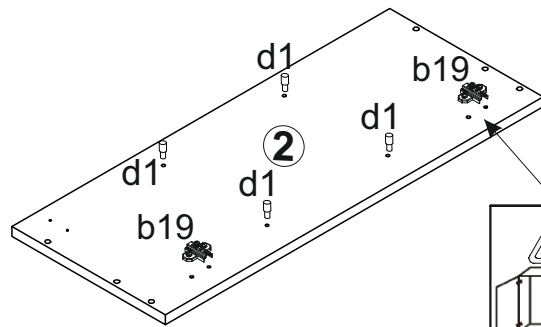
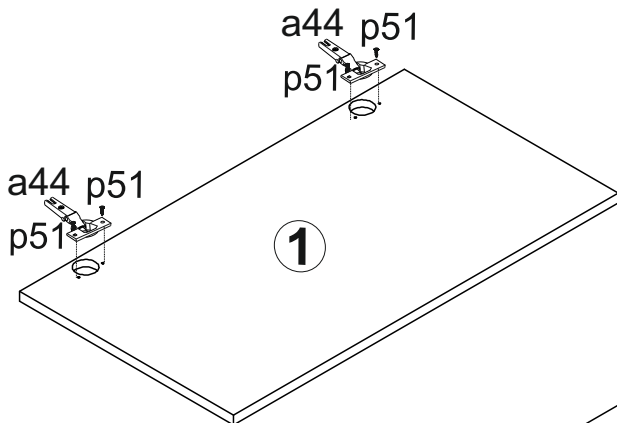
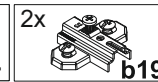
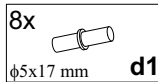
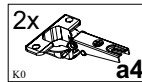
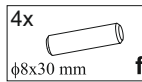

6

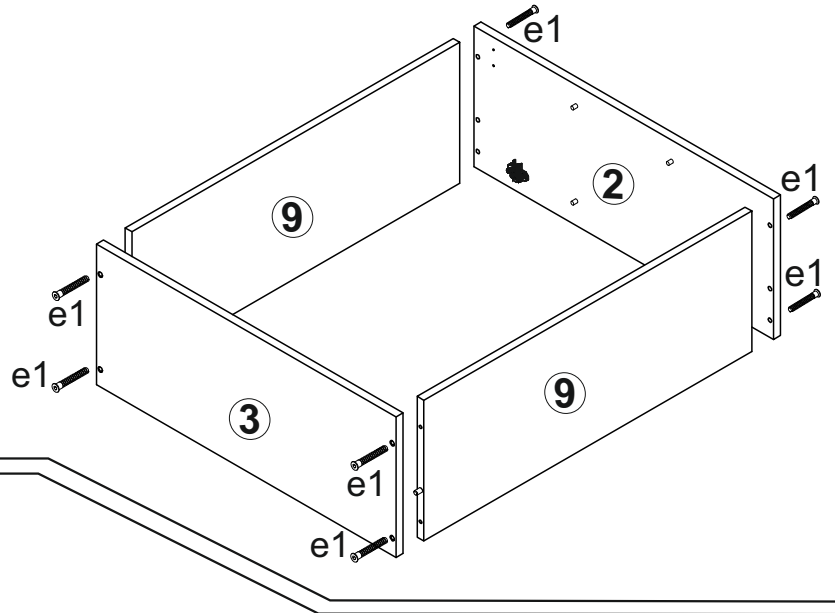
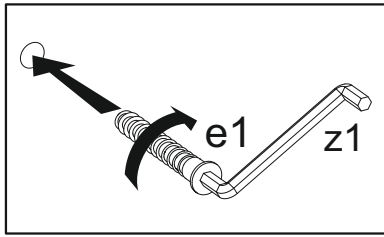
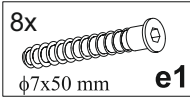

7

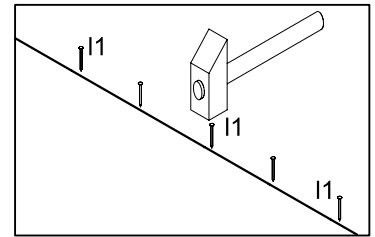
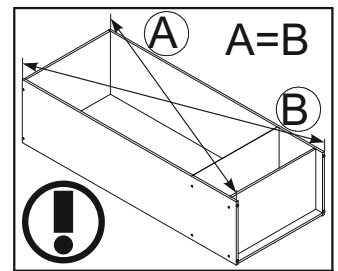
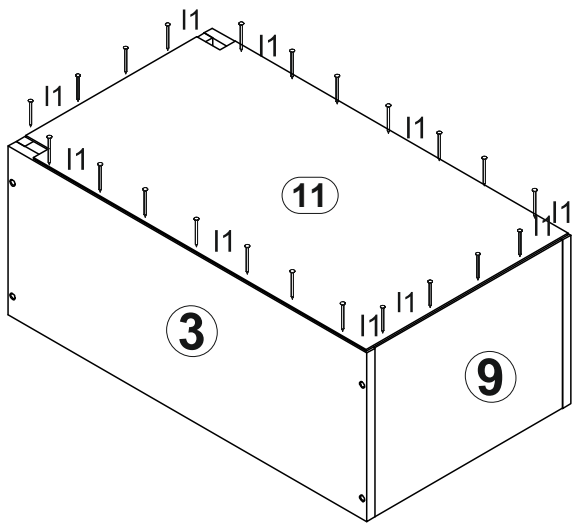
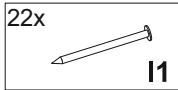

8

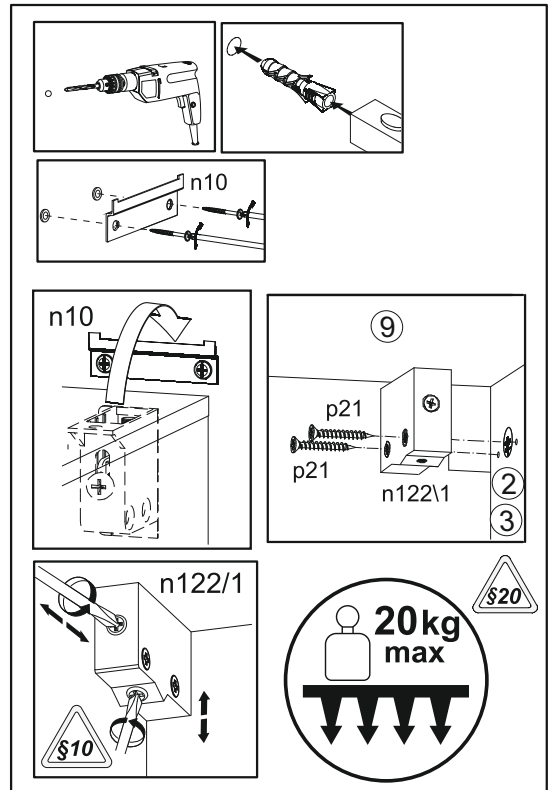
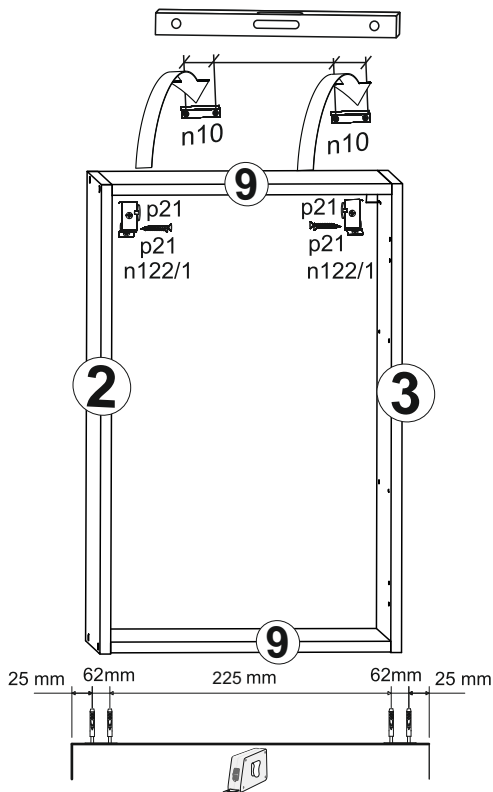
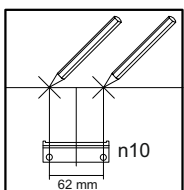
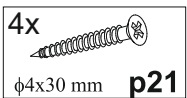
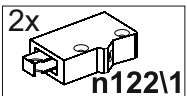
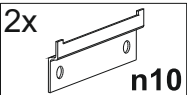
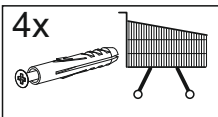

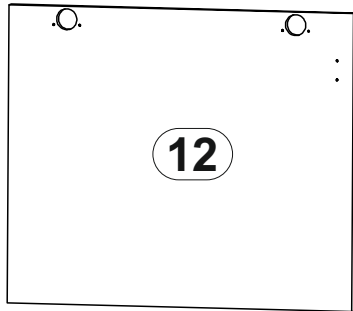
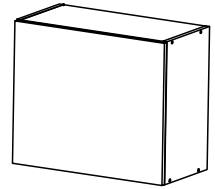
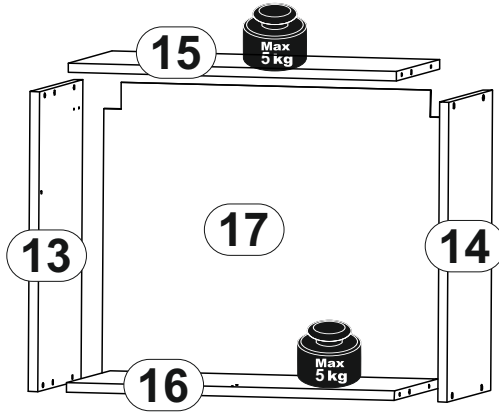

| A | B | C | D |
|----|----------|-----|-----|
| 12 | DI1 -006 | 596 | 500 |
| 13 | DI1 -105 | 503 | 285 |
| 14 | DI1 -106 | 503 | 285 |
| 15 | DI1 -304 | 567 | 285 |
| 16 | DI1 -308 | 567 | 285 |
| 17 | DI1 -908 | 498 | 595 |

9

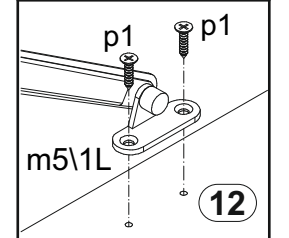
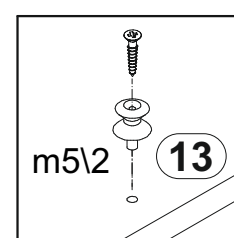
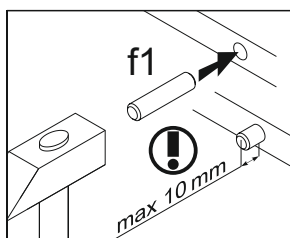
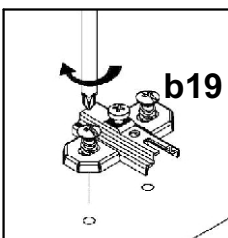
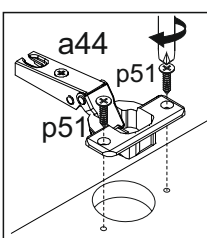
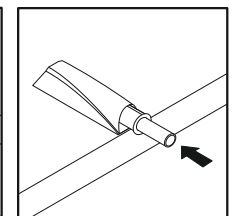
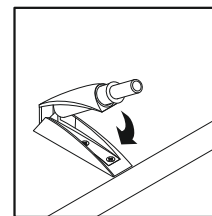
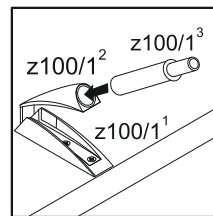
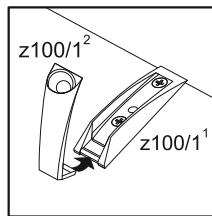
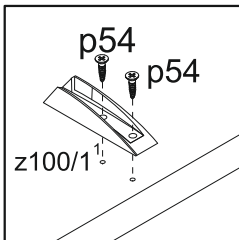
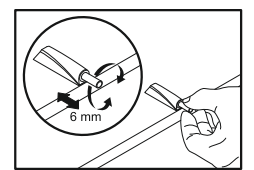
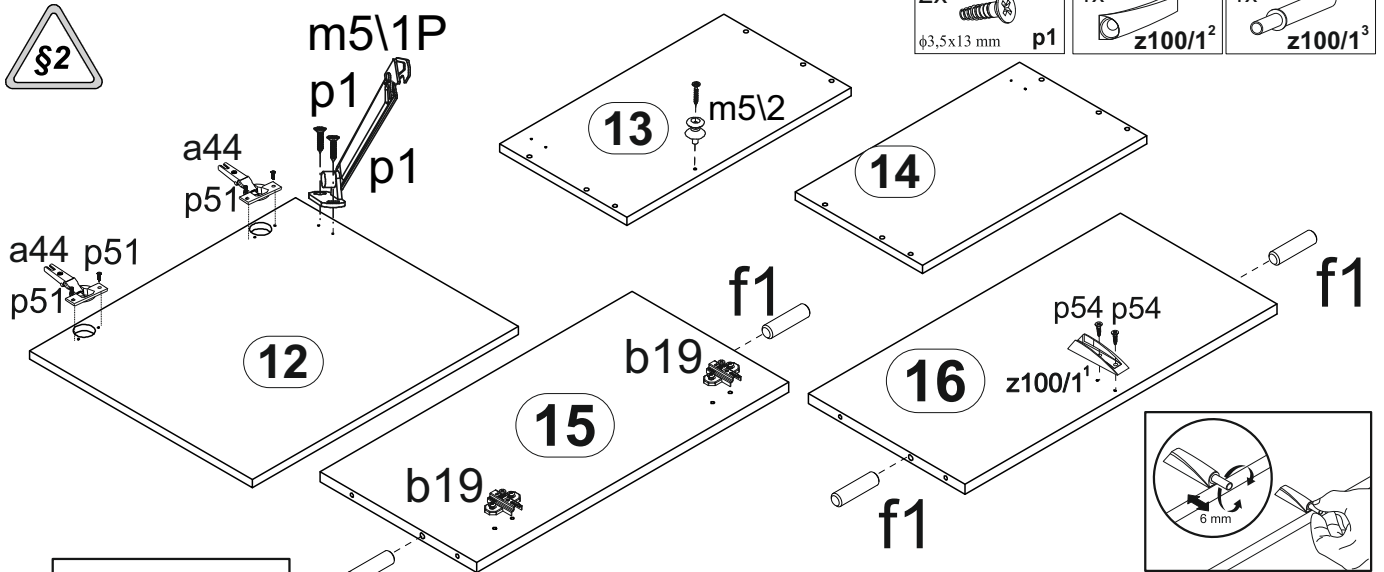
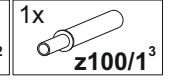
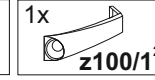
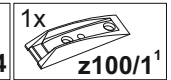
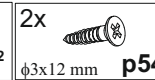
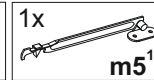
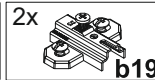
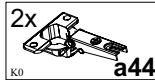
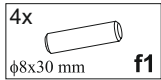

10



8x
φ7x50 mm e1

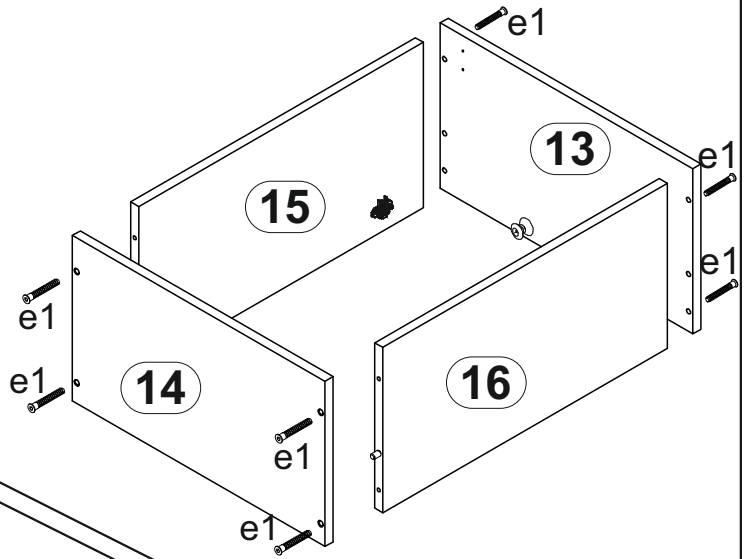
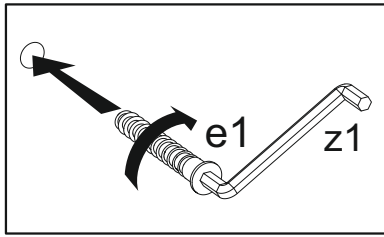

11

22x
l1

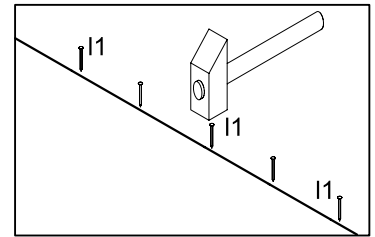
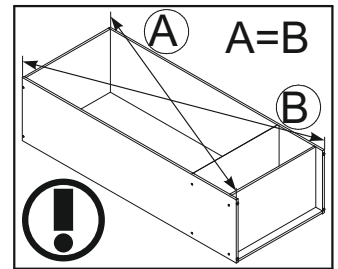
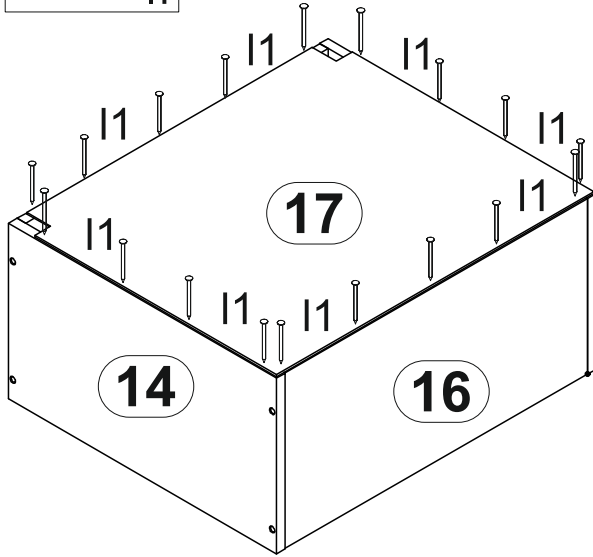

12



4x
n10

2x
n10

2x
n122/1

4x
φ4x30 mm p21

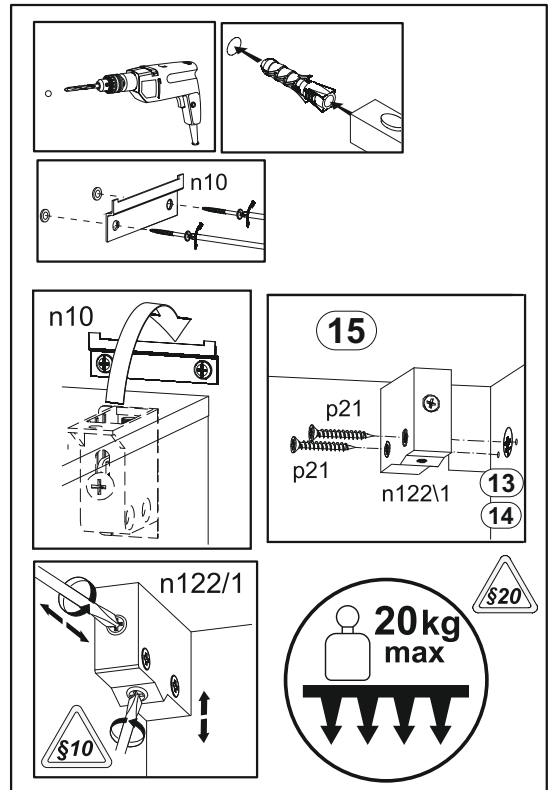
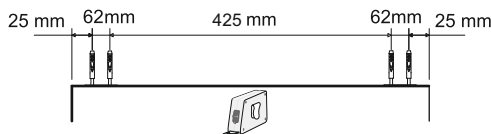
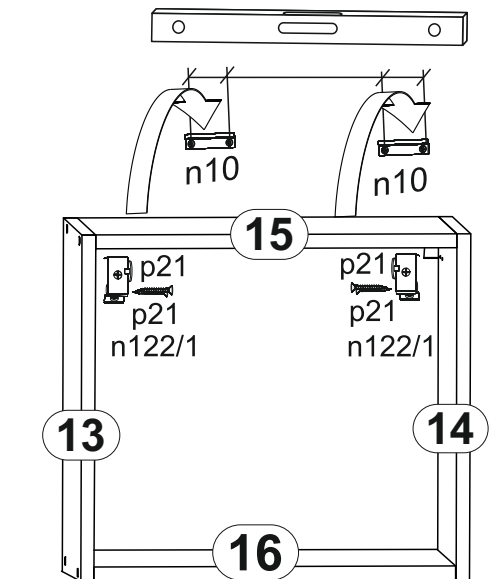
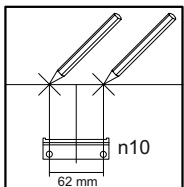

IV

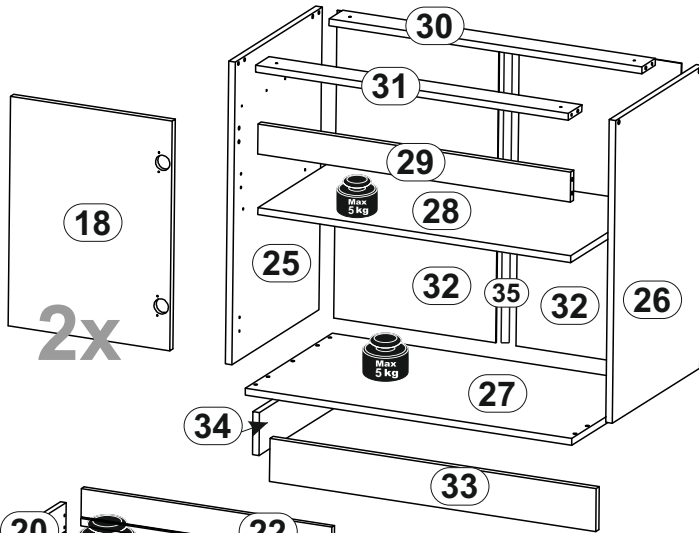
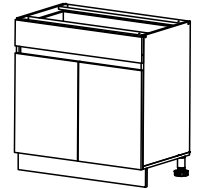

| A | B | C | D | |
|----|----------|-----|-----|-----|
| 18 | DI1 -002 | 534 | 396 | 6/8 |
| 19 | DI1 -001 | 796 | 140 | 7/8 |
| 20 | DI1 -502 | 400 | 100 | 7/8 |
| 21 | DI1 -504 | 400 | 100 | 7/8 |
| 22 | DI1 -503 | 710 | 100 | 7/8 |
| 23 | DI1 -410 | 383 | 80 | 3/8 |
| 24 | DI1 -909 | 399 | 725 | 4/8 |
| 25 | DI1 -107 | 704 | 450 | 1/8 |
| 26 | DI1 -108 | 704 | 450 | 1/8 |
| 27 | DI1 -201 | 800 | 450 | 4/8 |
| 28 | DI1 -301 | 767 | 430 | 3/8 |
| 29 | DI1 -401 | 767 | 70 | 3/8 |
| 30 | DI1 -406 | 767 | 70 | 3/8 |
| 31 | DI1 -407 | 767 | 70 | 3/8 |
| 32 | DI1 -903 | 715 | 397 | 4/8 |
| 33 | DI1 -403 | 800 | 100 | 4/8 |
| 34 | DI1 -413 | 410 | 100 | 6/8 |
| 35 | LH -686 | 686 | 14 | 4/8 |

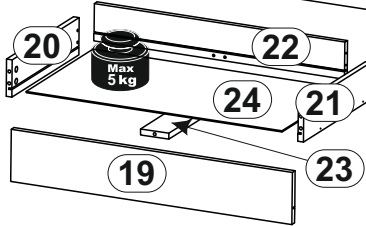

- 13**
- 14x $\phi 8 \times 30$ mm f1
 - 4x a44
 - 8x $\phi 3,5 \times 15$ mm p51
 - 4x b19
 - 1x 400 mm w5\CL
 - 1x 400 mm w5\CR
 - 6x $\phi 6 \times 13$ mm e3
 - 4x $\phi 5 \times 17$ mm d1

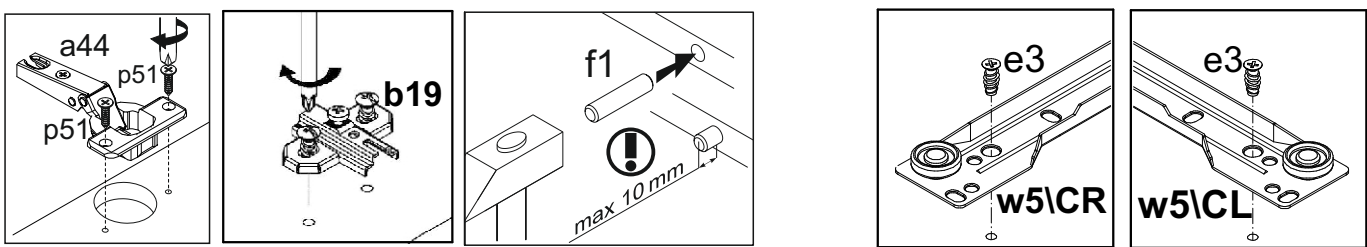
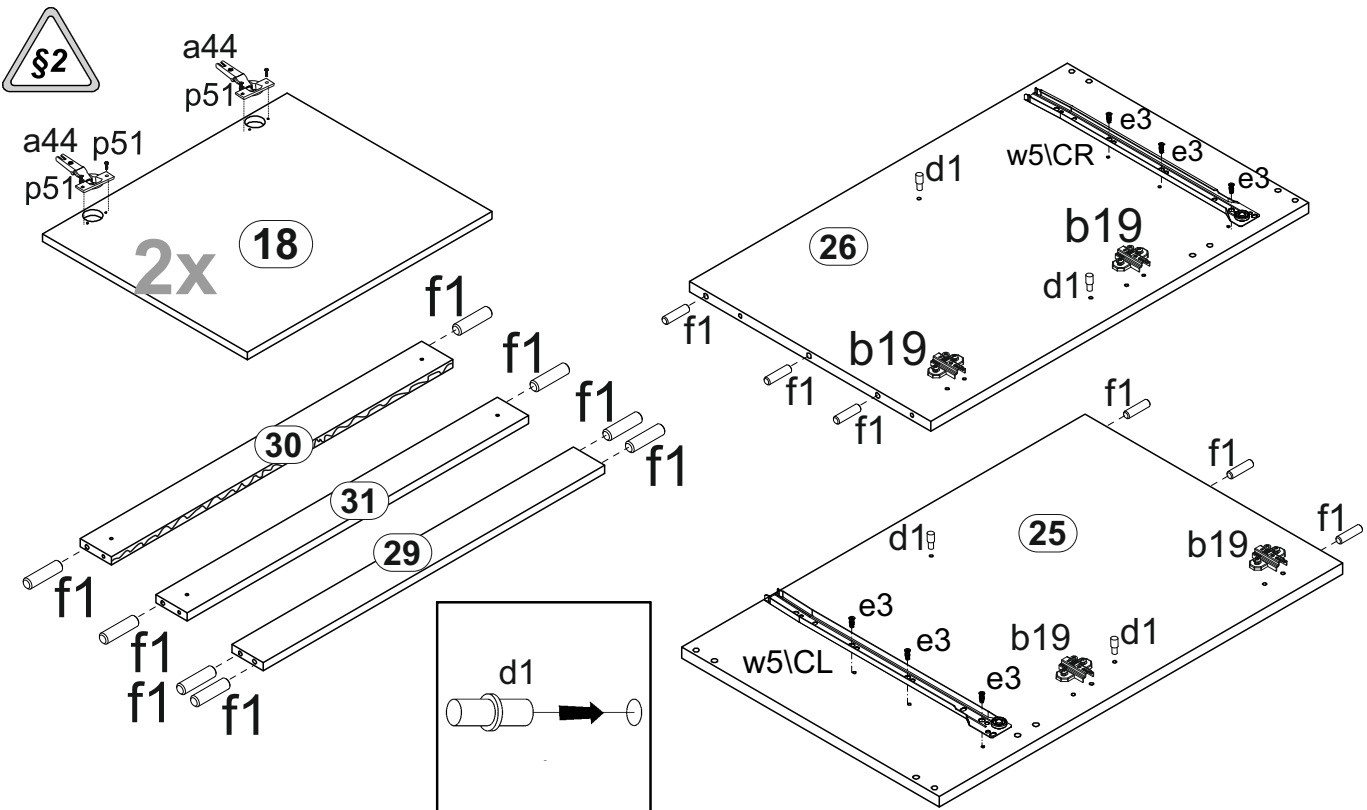

14

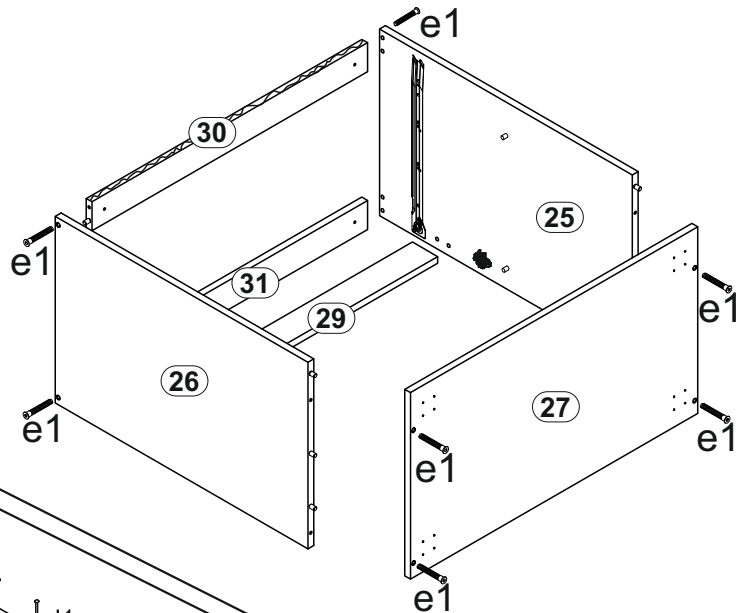
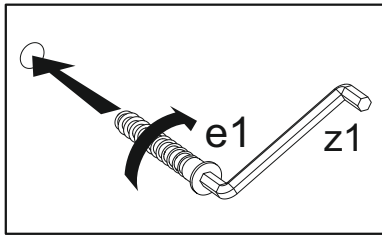
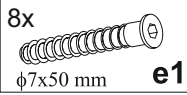

15

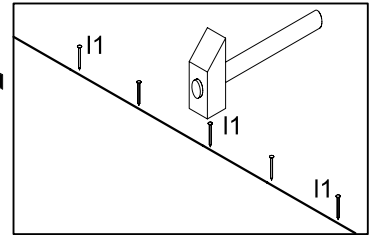
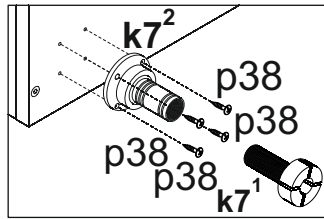
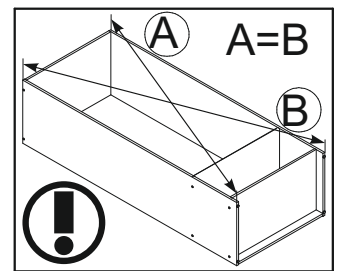
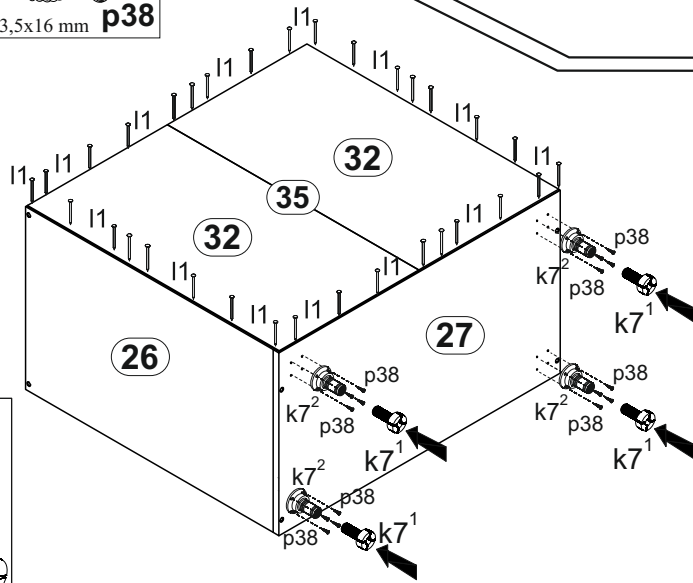
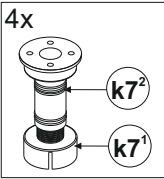
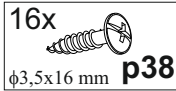
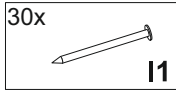

16

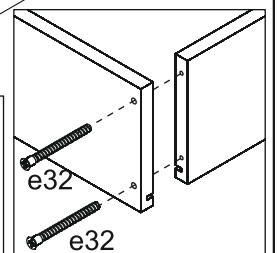
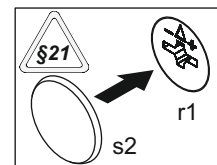
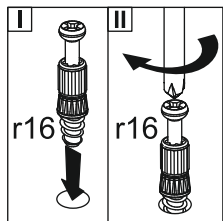
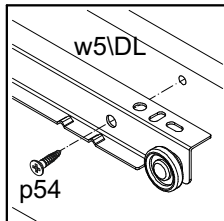
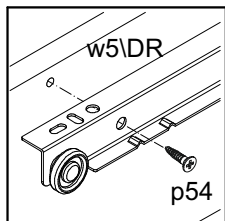
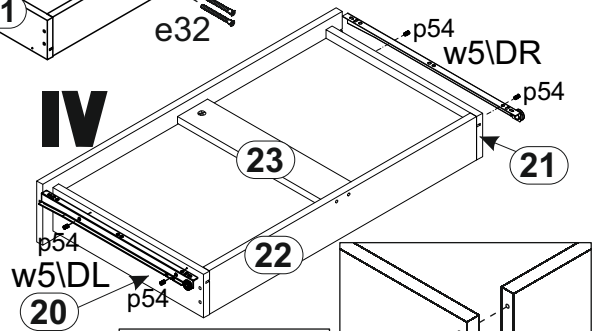
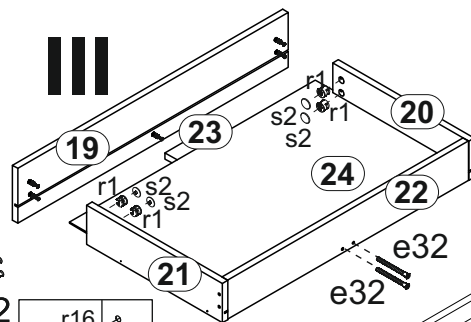
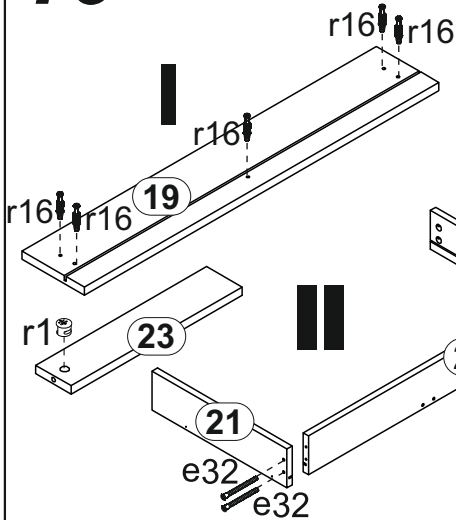
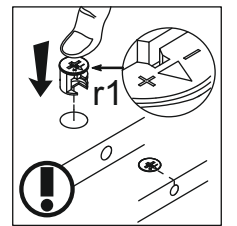
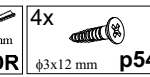
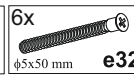
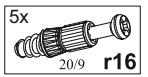
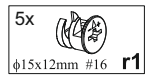

V

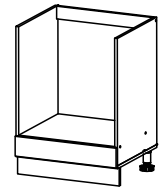
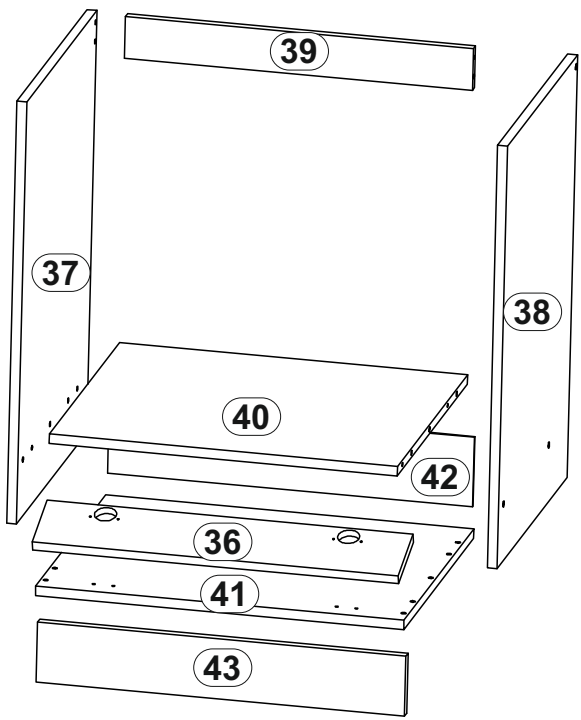

| A | B | C | D | |
|----|----------|-----|-----|-----|
| 36 | DI1 -004 | 110 | 596 | 6/8 |
| 37 | DI1 -101 | 704 | 495 | 1/8 |
| 38 | DI1 -102 | 704 | 495 | 1/8 |
| 39 | DI1 -409 | 567 | 70 | 2/8 |
| 40 | DI1 -309 | 567 | 495 | 3/8 |
| 41 | DI1 -202 | 600 | 495 | 3/8 |
| 42 | DI1 -902 | 116 | 595 | 1/8 |
| 43 | DI1 -411 | 600 | 100 | 6/8 |

17

- 14x $\phi 8 \times 30$ mm f1
- 2x a210
- 4x $\phi 3,5 \times 15$ mm p51
- 2x b105
- 1x z100/1²
- 1x z100/1³
- 2x $\phi 3 \times 12$ mm p54
- 1x z100/1¹

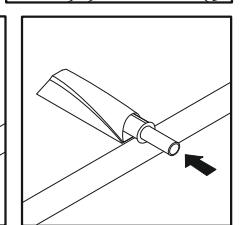
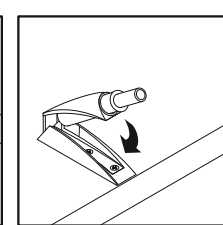
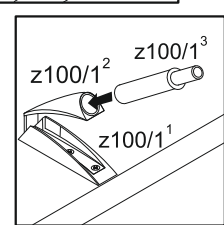
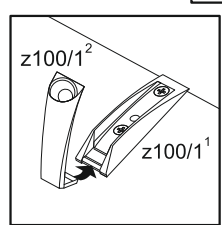
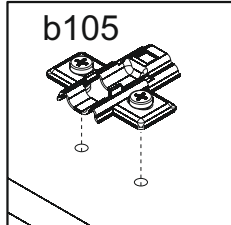
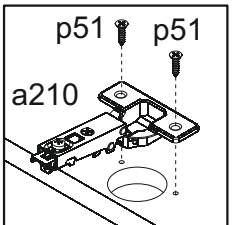
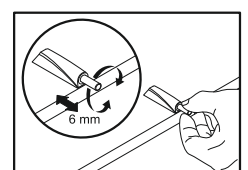
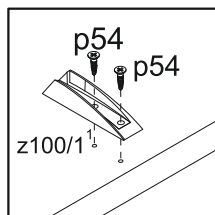
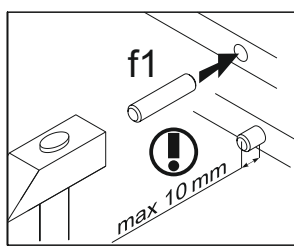
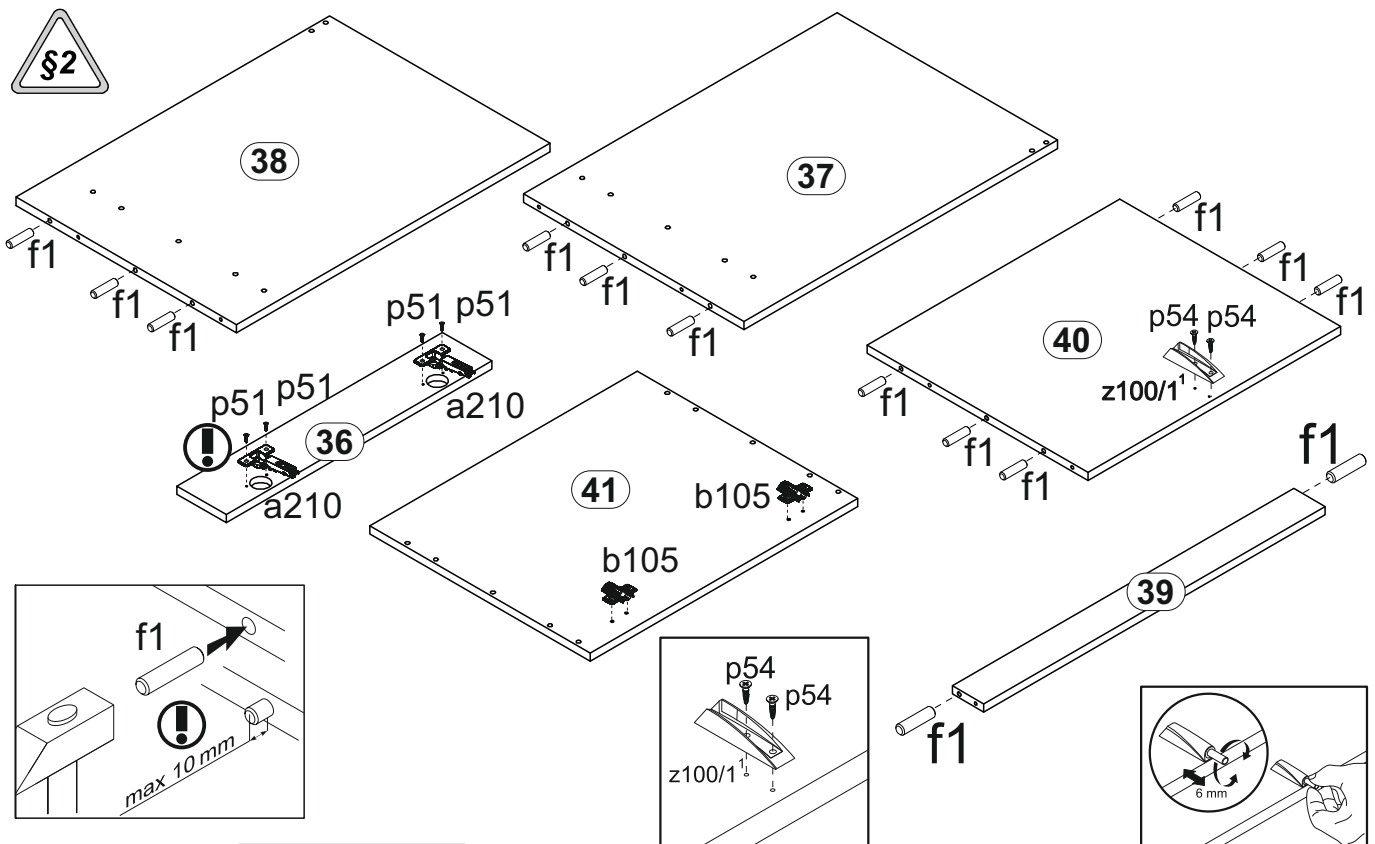

18

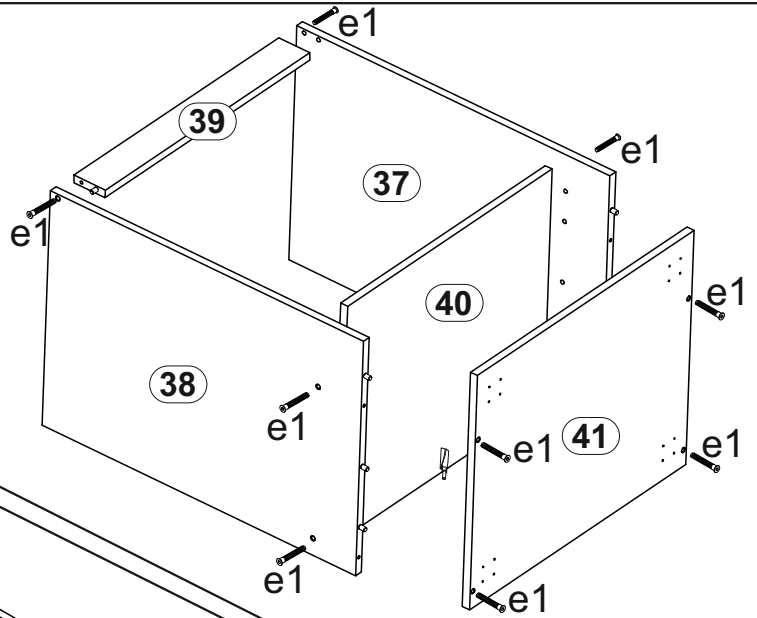
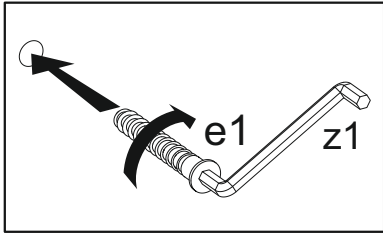
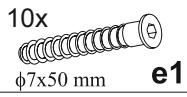

19

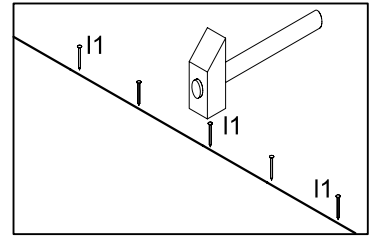
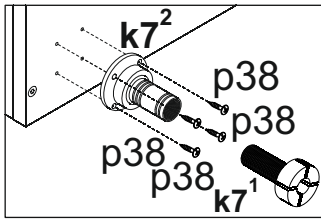
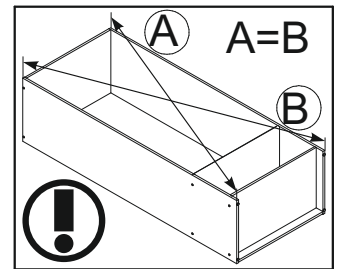
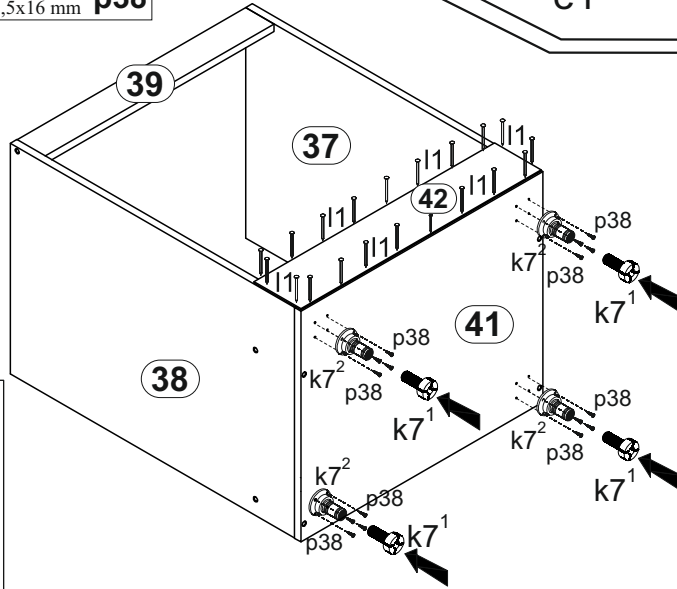
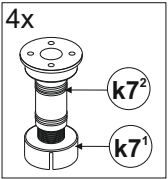
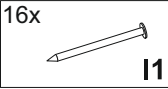

20

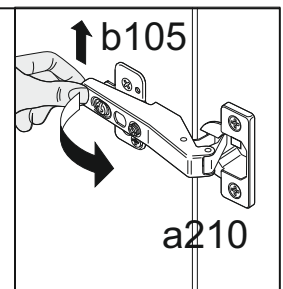
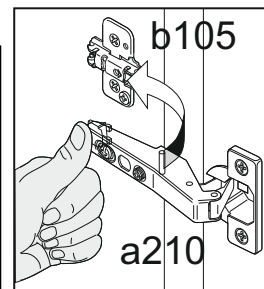
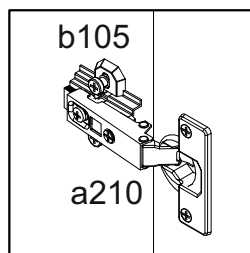
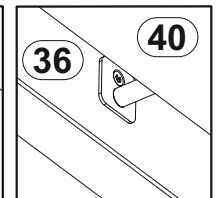
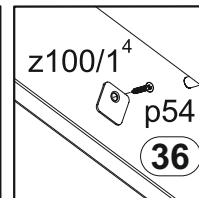
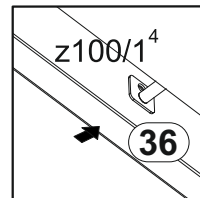
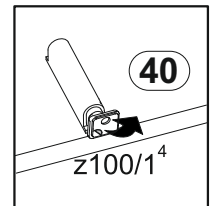
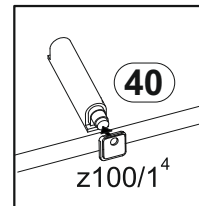
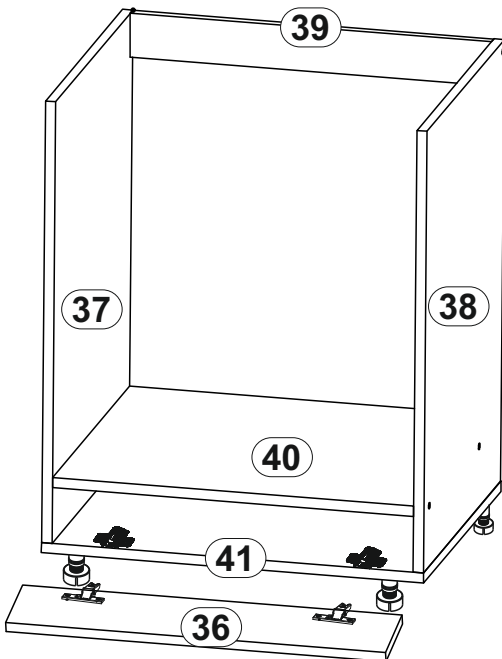

VI

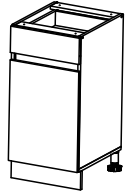
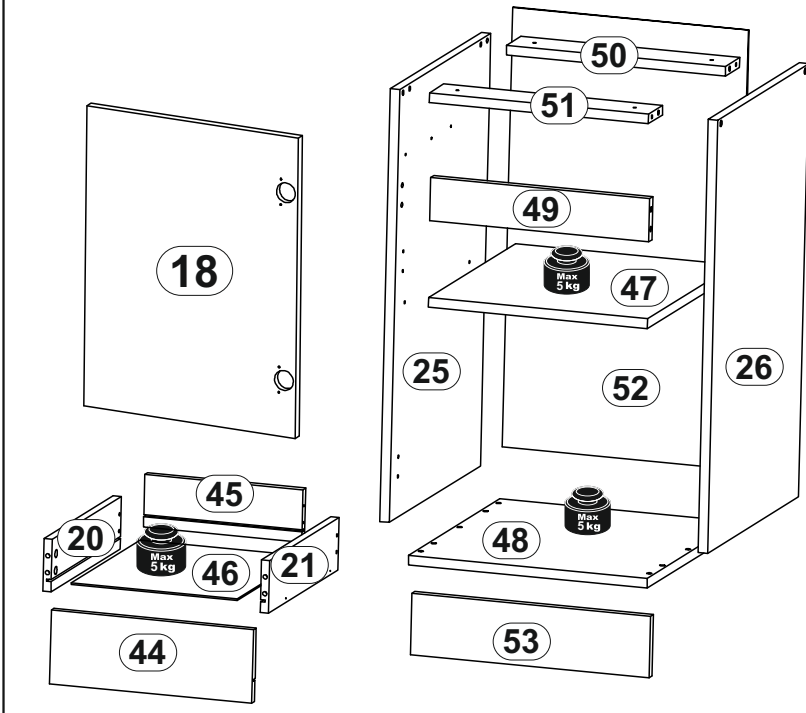

| A | B | C | D |
|----|----------|-----|-----|
| 18 | DI1 -002 | 534 | 396 |
| 20 | DI1 -502 | 400 | 100 |
| 21 | DI1 -504 | 400 | 100 |
| 25 | DI1 -107 | 704 | 450 |
| 26 | DI1 -108 | 704 | 450 |
| 44 | DI1 -003 | 396 | 140 |
| 45 | DI1 -501 | 310 | 100 |
| 46 | DI1 -910 | 399 | 325 |
| 47 | DI1 -307 | 367 | 430 |
| 48 | DI1 -203 | 400 | 450 |
| 49 | DI1 -402 | 367 | 70 |
| 50 | DI1 -404 | 367 | 70 |
| 51 | DI1 -405 | 367 | 70 |
| 52 | DI1 -901 | 715 | 395 |
| 53 | DI1 -412 | 400 | 100 |



- 21** 14x $\phi 8 \times 30$ mm f1 2x a44 4x $\phi 3.5 \times 15$ mm p51 2x b19 1x 400 mm w5\CL 1x 400 mm w5\CR 6x $\phi 6 \times 13$ mm e3 4x $\phi 5$ s4 4x $\phi 5 \times 17$ mm d1

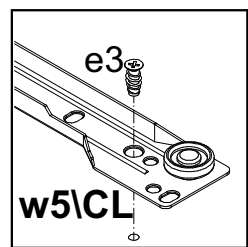
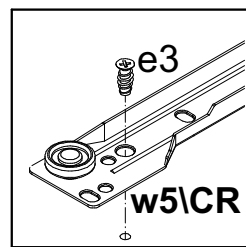
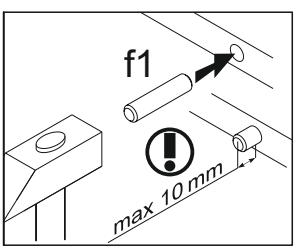
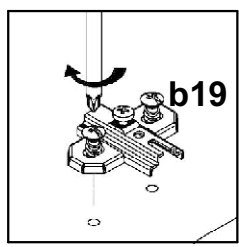
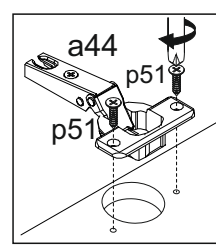
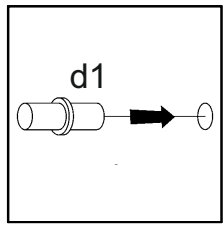
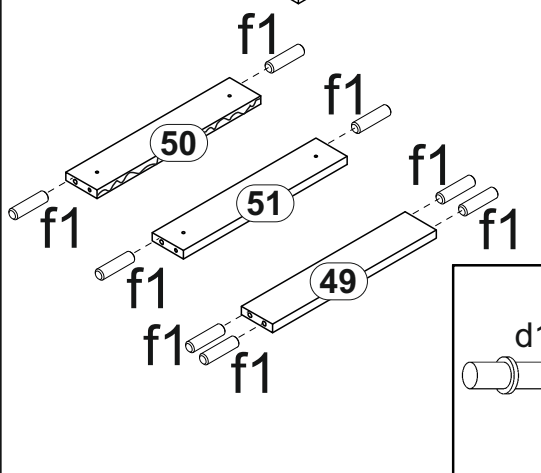
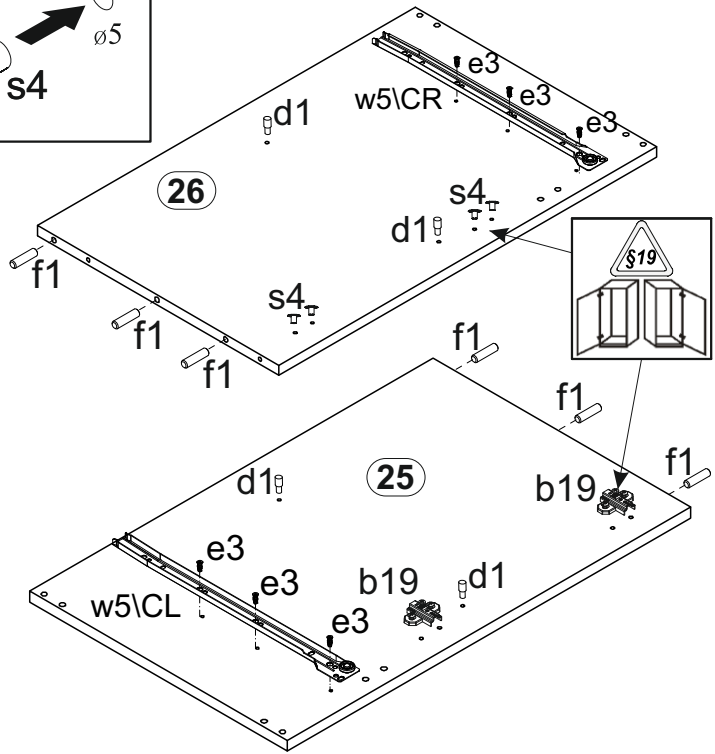
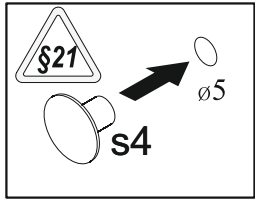
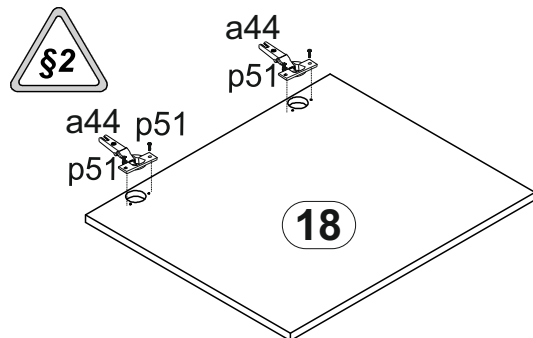

22



8x
φ7x50 mm e1

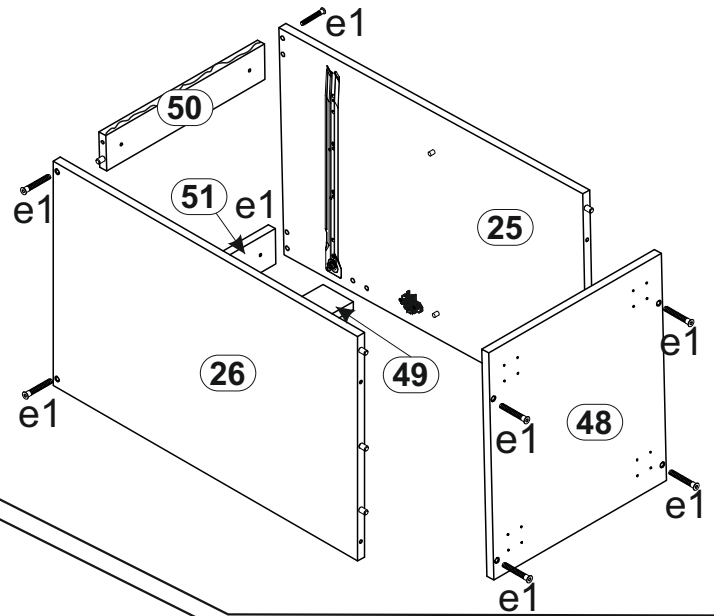
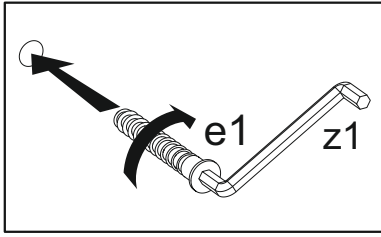

23

22x
l1

16x
φ3,5x16 mm p38

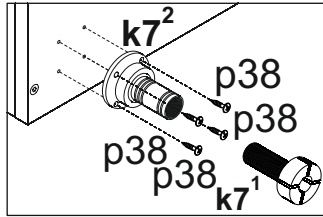
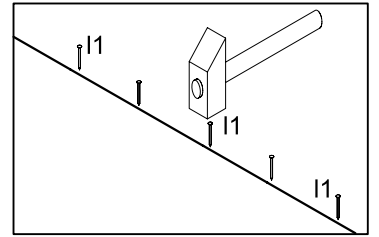
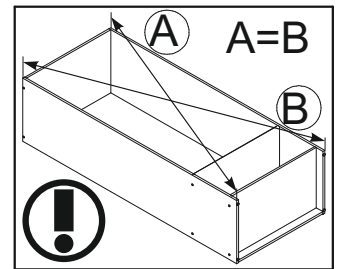
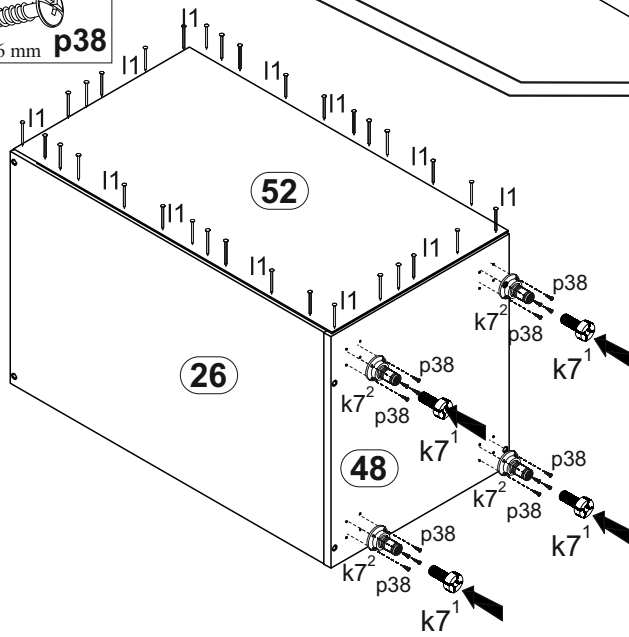
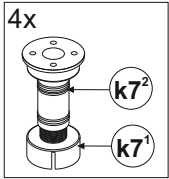

24

4x
φ15x12mm #16 r1

4x
20/9 r16

4x
φ16 s2

4x
φ5x50 mm e32

1x
400 mm w5\DL

1x
400 mm w5\DR

4x
φ3x12 mm p54

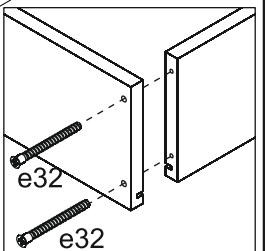
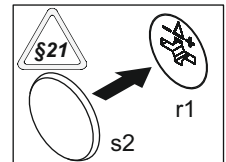
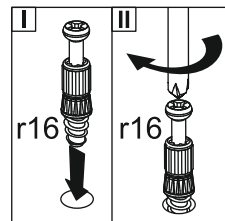
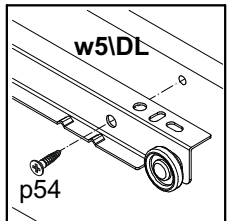
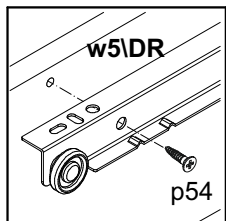
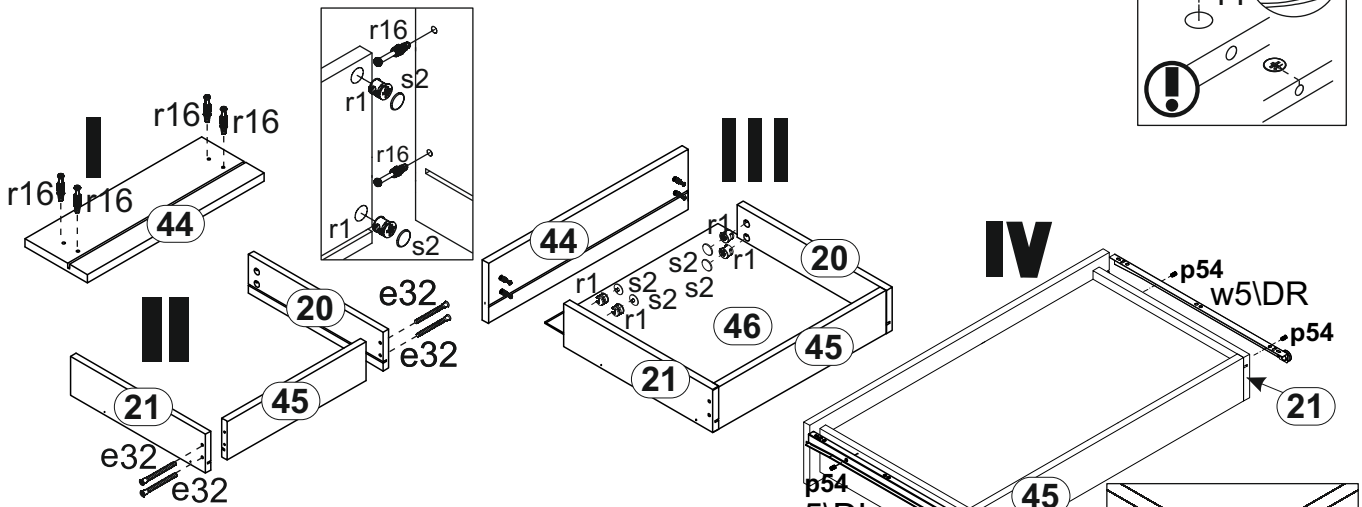
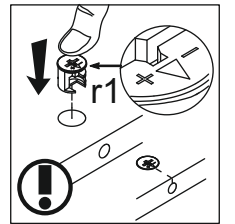

VII

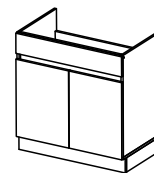
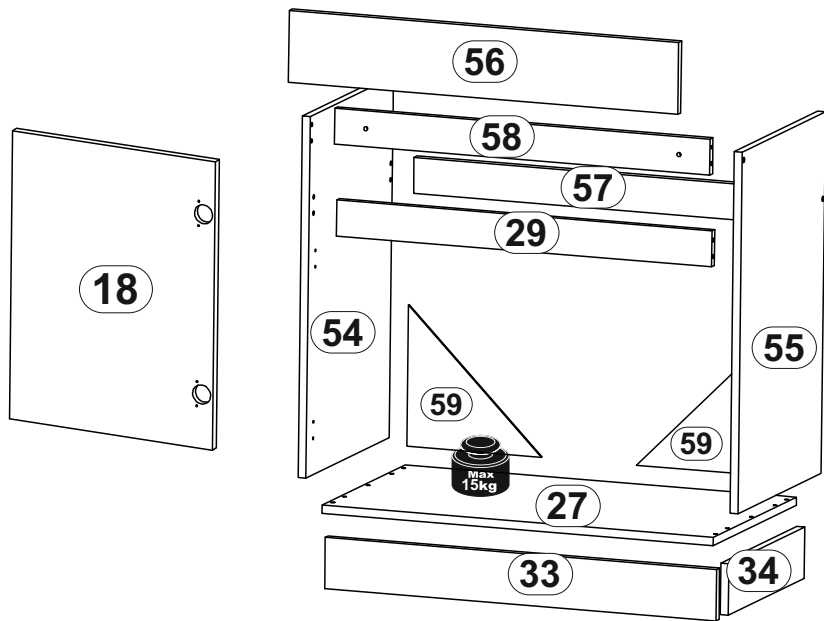

| A | B | C | D | |
|----|----------|-----|-----|-----|
| 18 | DI1 -002 | 534 | 396 | 6/8 |
| 27 | DI1 -201 | 800 | 450 | 4/8 |
| 29 | DI1 -401 | 767 | 70 | 3/8 |
| 33 | DI1 -403 | 800 | 100 | 4/8 |
| 34 | DI1 -413 | 410 | 100 | 6/8 |
| 54 | DI1 -109 | 704 | 450 | 1/8 |
| 55 | DI1 -110 | 704 | 450 | 1/8 |
| 56 | DI1 -007 | 796 | 140 | 7/8 |
| 57 | DI1 -408 | 767 | 70 | 3/8 |
| 58 | DI1 -414 | 767 | 70 | 3/8 |
| 59 | DI1 -904 | 275 | 275 | 1/8 |

25

- 14x $\phi 8 \times 30$ mm f1
- 4x a44
- 8x $\phi 3,5 \times 15$ mm p51
- 4x b19

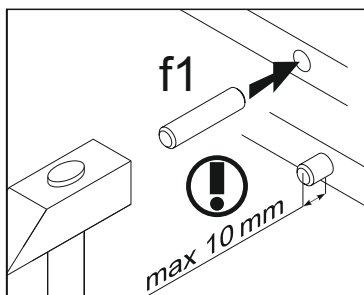
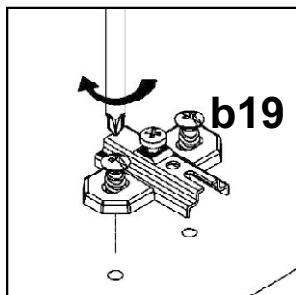
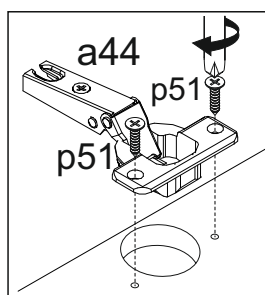
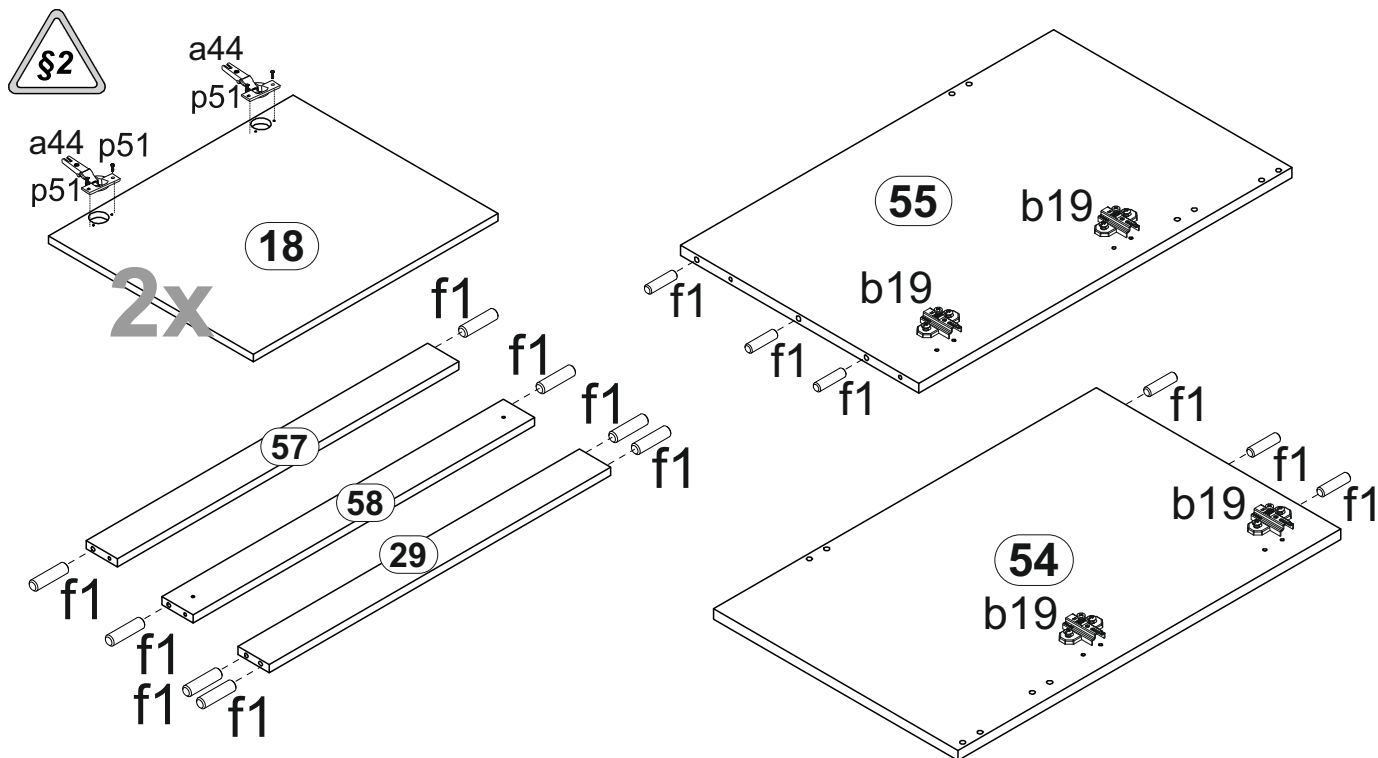

26

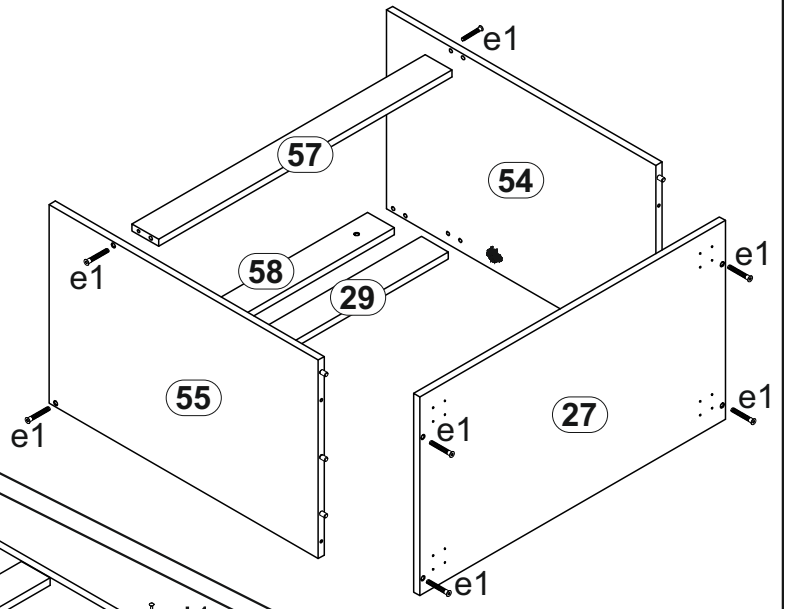
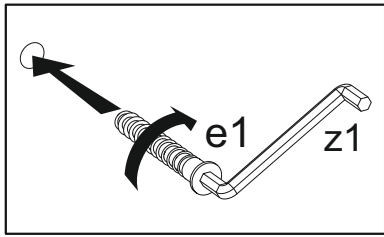
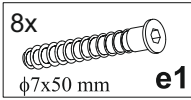

27

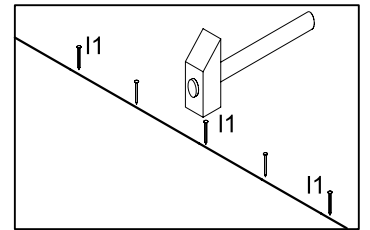
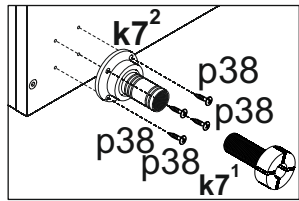
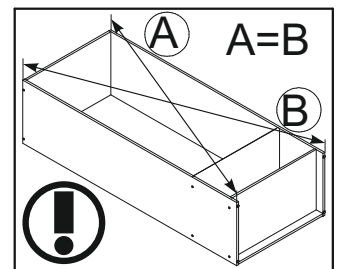
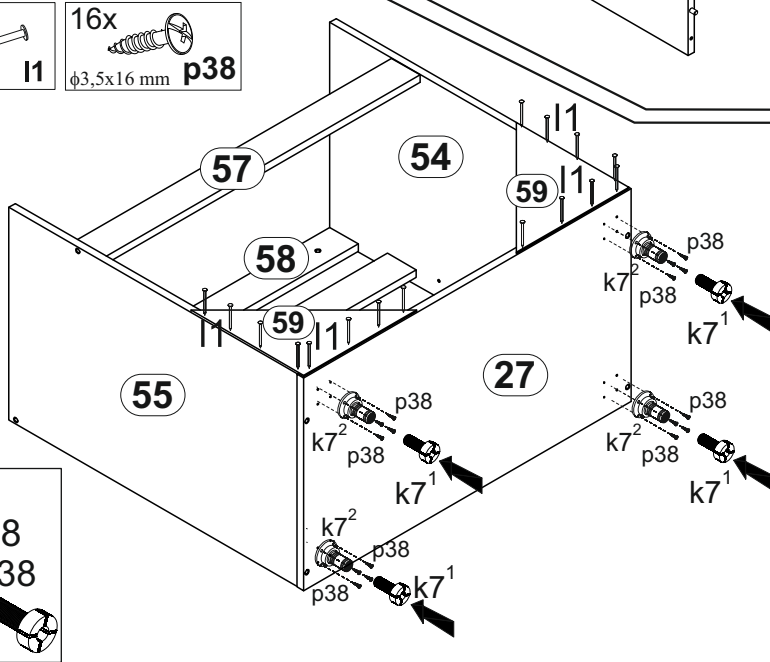
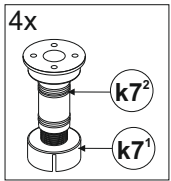
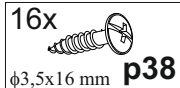
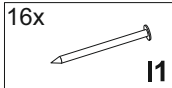

28

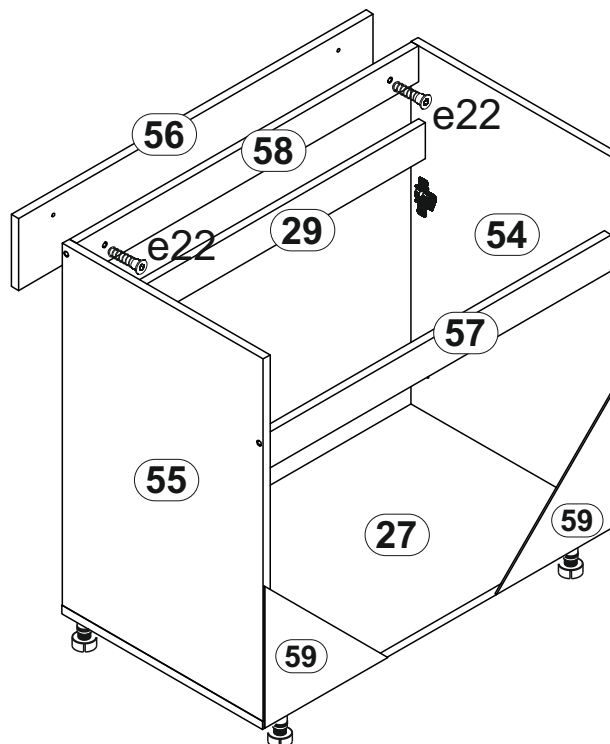
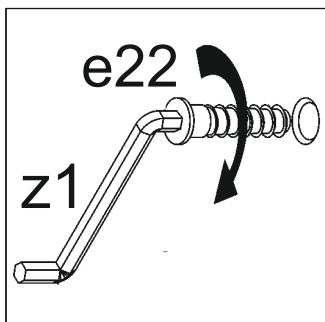
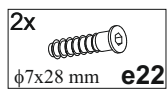

29

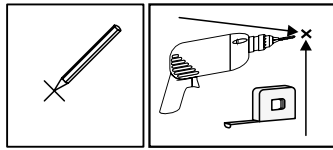
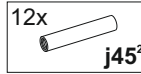
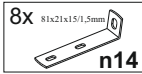

| A | B | C | D |
|----|----------|------|-----|
| 60 | DI1 -204 | 1200 | 600 |
| 61 | DI1 -205 | 1400 | 600 |

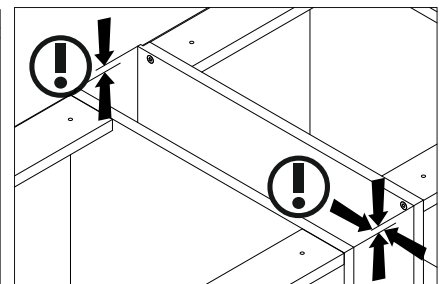
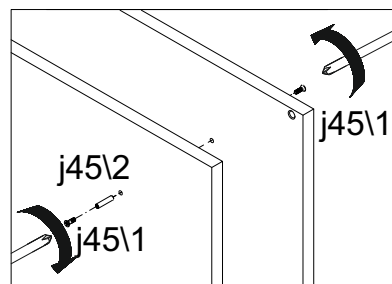
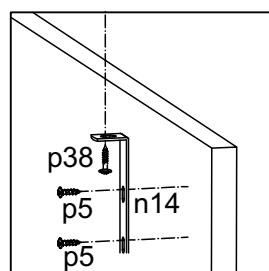
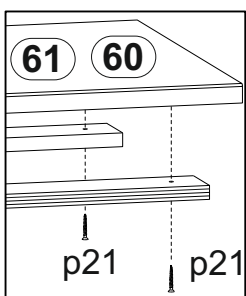
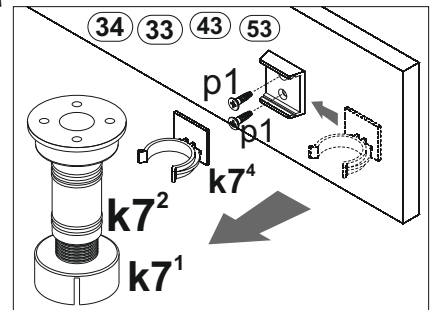
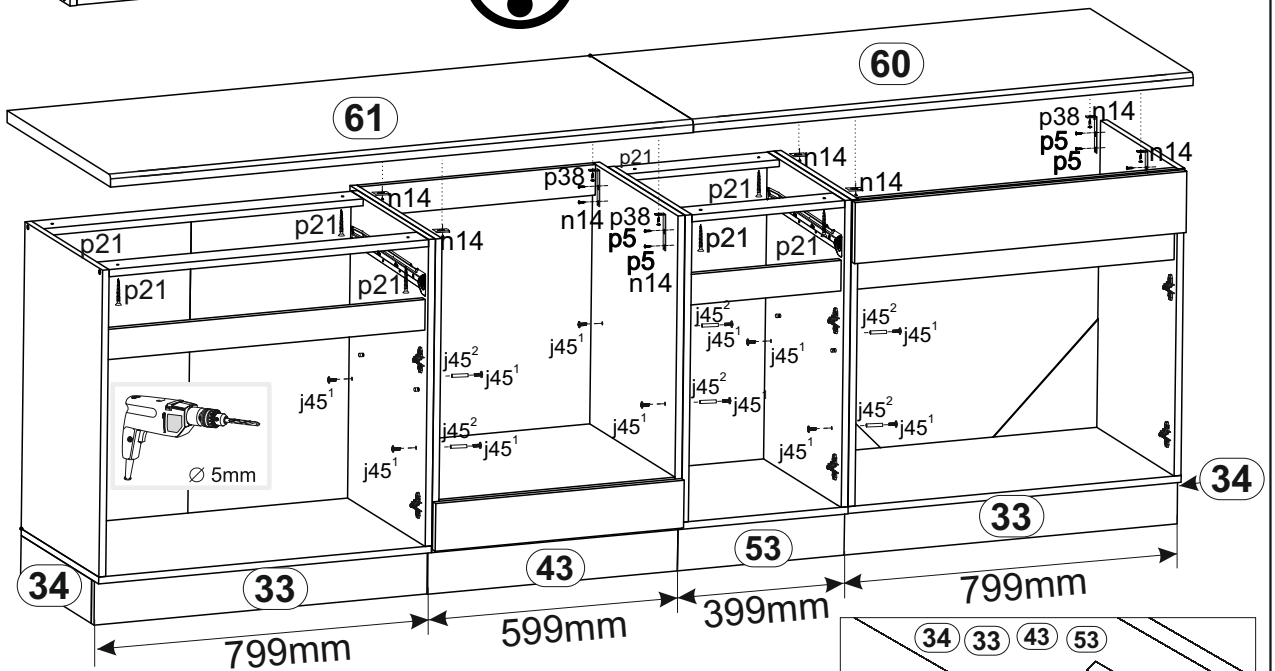
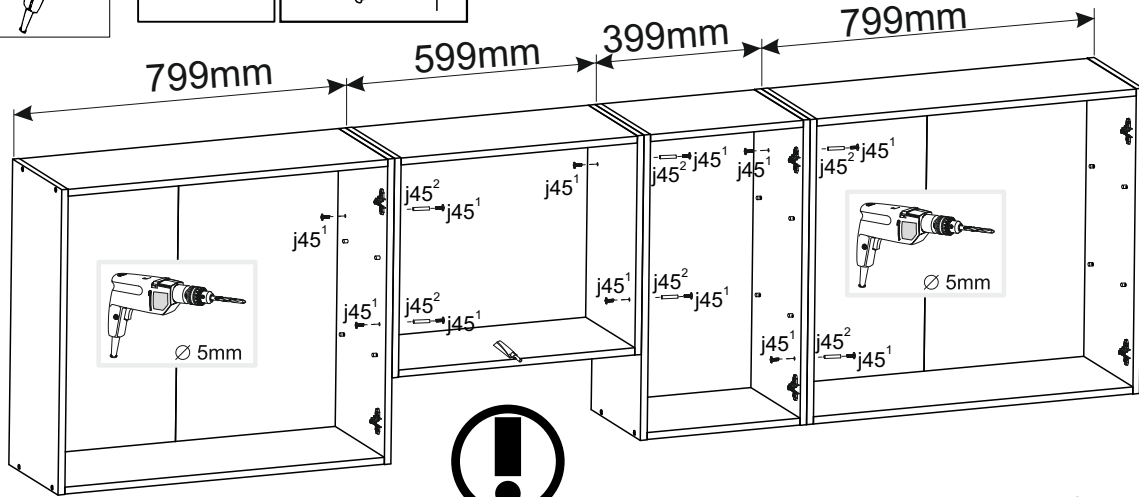

30

32x  $\phi 5 \times 17$ mm d1

16x  s1

2x  $\phi 3 \times 12$ mm p54

2x  z100/1⁴

