

TALLIN TULUZA

02

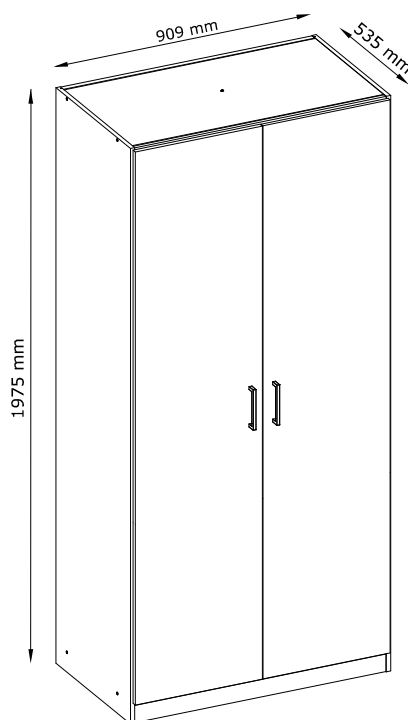

D **Montageanleitung**
Kleiderschrank >Tallin/Tuluza<

FR **Notice de montage**
Armoire >Tallin/Tuluza<

NL **Handleiding voor de montage**
Kast >Tallin/Tuluza<

CZ **Montážní návod**
Kabinet >Tallin/Tuluza<

HU **Szerelési útmutató**
Szekrény >Tallin/Tuluza<

TR **Montaj talinatl**
Dolap >Tallin/Tuluza<

ES **Instrucciones de montaje**
Armario >Tallin/Tuluza<

BG **Инструкции за сглобяване**
Гардероб >Tallin/Tuluza<

GB **Assembly instrutions**
Wardrobe >Tallin/Tuluza<

IT **Intruzioni di montaggio**
Armadio >Tallin/Tuluza<

PL **Instrukcja montažu**
Szafa >Tallin/Tuluza<

SK **Návod na montáž**
Skriňa >Tallin/Tuluza<

RO **Instructiuni de montaj**
Cabinet >Tallin/Tuluza<

RU **Инструкция по монтажу**
Шкаф >Tallin/Tuluza<

PT **Instruções de montagem**
Guarda-roupa >Tallin/Tuluza<

BA **Upute za sastavljanje**
Garderoba >Tallin/Tuluza<

SRB **Упутства за инсталацију**
Гардеробу >Tallin/Tuluza<

HR **Upute za instalaciju**
Ormar >Tallin/Tuluza<

SL **Návod na montaž**
Kabinet >Tallin/Tuluza<

LT **Surinkimo instrukcijos**
Kabinetas >Tallin/Tuluza<

LV **Montāžas instrukcija**
Ministru kabinets >Tallin/Tuluza<

EE **Kokkupaneku juhised**
Kabinet >Tallin/Tuluza<

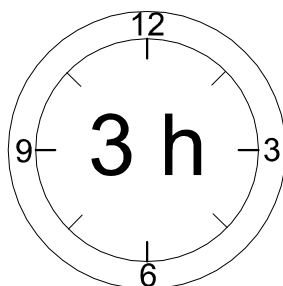

D-Ziehen Sie alle Schrauben sowie tragende Verbindungsteile nach ca. 5 Wochen nach, um einedauerhafte Standsicherheit zu gewährleisten.

GB-After approx. 5 weeks, tighten all screws and load-bearing connecting parts to ensure permanent stability.

FR-Resserrez toutes les vis ainsi que les pièces de fixation au bout d'environ 5 semaines pour garantir une sécurité de fixation durable.

IT- Ristringere tutte le viti e giunture dopo ca. 5 settimane, al fine di garantire una durevole solidità.

NL-Draai alle schroeven en ook dragende verbindingstukken na ca. 5 weken nog eens vast, zodat een continue stabiliteit wordt gegarandeerd.

PL-Prosimy po ok. 5 tygodniach dokręcić wszystkie śruby i elementy łączeniowe. Zagwarantuje to Państwu trwałość i stabilność połączeń.

CZ- Dotáhněte všechny šrouby a nosné spojovací díly přibližně po 5 týdnech, aby se zaručila trvalá stabilita.

SK-Po cca 5 týždňoch dotiahnite skrutky, aby bola zaručená ich trvalá stabilita.

HU-Húzza utána - kb. 5 hét múlva - az összes csavart és a teherhordó összekötő-alkatrészeket abiztonság érdekében.

RO-Pentru a asigura o stabilitate de durată, strângeți după cca. 5 săptămâni toate șuruburile, precum și toate elementele portante de legătură.

TR-Tüm vida ve taşıyıcı bağlantı parçalarını kalıcı bir duruş güvenliğini sağlamak için yaklaşık 5 haftasonra tekrar sıkınız.

RU - Подкрутите все болты, а также несущие соединительные детали прикл. через 5 недель для обеспечения устойчивости в течение длительного времени.

SRB - Молим вас после акрокса. 5 недеља затегните све шрафове и причвршћиваче. То ће вам гарантовати трајност и стабилност веза.

HR - Molim vas, nakon cca. 5 tjedana zategnite sve vijke i pričvršćivače. To će vam jamčiti trajnost i stabilnost priključaka.

SL - Pýtame sa po cca. 5 týždňov utiahnite všetky skrutky a upevňovacie prvky. To zaručuje trvanlivosť a stabilitu spojov.

LT - Mes prašome po maždaug. 5 savaites priveržkite visus varžtus ir tvirtinimo detales. Taip užtikrinamas jungčių patvarumas ir stabilumas.

LV - Mēs lūdzam pēc apm. 5 nedēļas, pievelciet visas skrūves un stiprinājumus. Tas garantē savienojumu izturību un stabilitāti.

EE - Küsime pärast ca. 5 nädalat, pingutage kõiki kruvisid ja kinnitusi. See tagab ühenduste vastupidavuse ja stabiilsuse.

ES Apriete todos los tornillos y elementos de conexión después de aprox. 5 semanas. Esto le garantizará la durabilidad y estabilidad de sus conexiones.

PT Aperte todos os parafusos e elementos de ligação após aprox. 5 semanas. Isto garantirá a durabilidade e estabilidade das suas ligações.

BA Zategnite sve zavrtnje i spojne elemente nakon cca. 5 sedmica. To će vam garantirati trajnost i stabilnost vaših veza.

BG Моля, затегнете всички винтове и свързващи елементи след прикл. 5 седмици. Това ще ви гарантира дълготрайност и стабилност на вашите връзки.

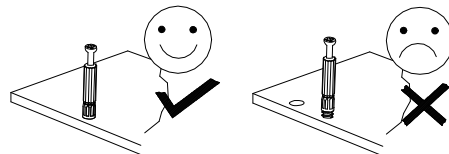

D Bitte nur mit einem Staubtuch oder leicht feuchtem Lappen reinigen. Keine scheuernden Putzmittel verwenden.

GB Please only clean with a duster or a damp cloth. Do not use any abrasive cleaners.

FR Veuillez nettoyer uniquement avec un chiffon à poussière ou un chiffon légèrement humide. Nepas utiliser de détergent abrasif.

IT Si raccomanda di pulire solo con un panno per la polvere o uno strofinaccio umido. Non utilizzare detersivi abrasivi.

NL Reinig alleen met een stofdoek of een lichtjes vochtige doek. Gebruik geen schurende poetsmid-delen.

PL Czyszczenie należy wykonać wyłącznie za pomocą ściereczki lub lekko nawilżonego ręcznika. Nie stosować środków czyszczących do szorowania.

CZ Čistěte prosím jen prachovkou nebo lehce navlhčeným hadrem. Nepoužívejte drhnutí čistící prostředky.

SK Na čistenie používajte len prachovku alebo zľahka navlhčenú utierku. Nepoužívajte žiadne drhnuce čistiace prostriedky.

HU Kérjük, csak portórlő kendővel vagy enyhén nedves ronggyal tisztítsa. Ne használjon dörzshatású tisztítószert.

RO Vă rugăm să utilizați la curățare exclusiv o cârpă de șters praful sau o cârpă ușor umezită. Nu utilizați substanțe de curățat abrazive.

TR Lütfen sadece bir toz bezikle veya hafif nemli yumuşak bir bezle siliniz. Aşındırıcı temizlik malze-meleri kullanmayınız.

RU Для чистки используйте, пожалуйста, тряпку для пыли или слегка влажную ветошь. Неиспользовать абразивные чистящие средства.

SBR Чишћење треба обавити само крпом или благо влажним пешкиром. Немојте користити средство за чишћење рибања.

HR Čišćenje treba obaviti samo krpom ili blago navlaženim ručnikom. Ne koristite sredstva za čišćenje ribanja.

SL Čistenie by sa malo vykonávať len handričkou alebo ľahko navlhčeným uterákom. Nepoužívajte čistiace prostriedky na drhnutie.

LT Valyti galima tik šluoste arba lengvai sudrėkintu rankšluosčiu. Nenaudokite šveičiamųjų valiklių.

LV Tīršana jāveic tikai ar drānu vai viegli samitrinātu dvieli. Neizmantojiet tīršanas līdzekļus.

EE Puhastada tohib ainult lapiga või kergelt niisutatud rätikuga. Ärge kasutage puhastusvahendeid.

ES La limpieza debe realizarse únicamente con un paño o toalla ligeramente húmedo. No utilice agentes de limpieza abrasivos.

PT A limpeza deve ser feita apenas com um pano ou toalha ligeiramente húmida. Não utilize produtos de limpeza abrasivos.

BG Почистването трябва да става само с парцал или леко навлажнена кърпа. Не използвайте абразивни почистващи препарати.

BA Čišćenje treba obavljati samo krpom ili blago vlažnim peškirom. Nemojte koristiti abrazivna sredstva za čišćenje.

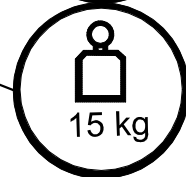
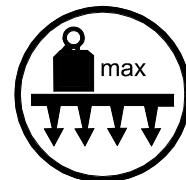
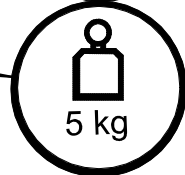
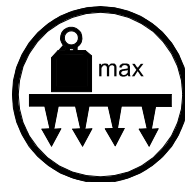
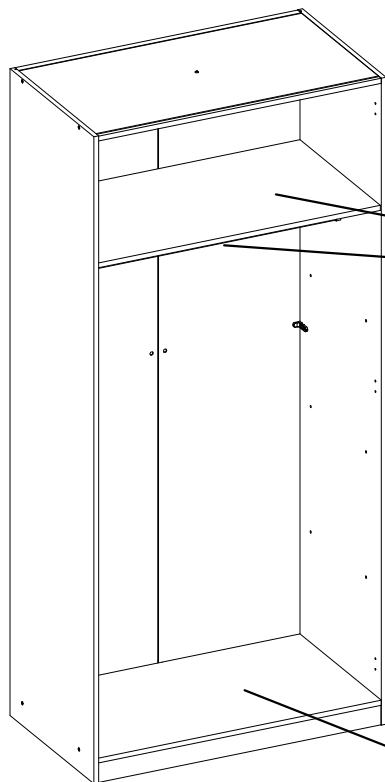
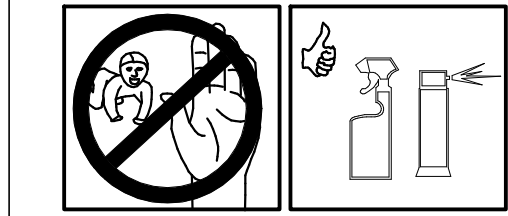
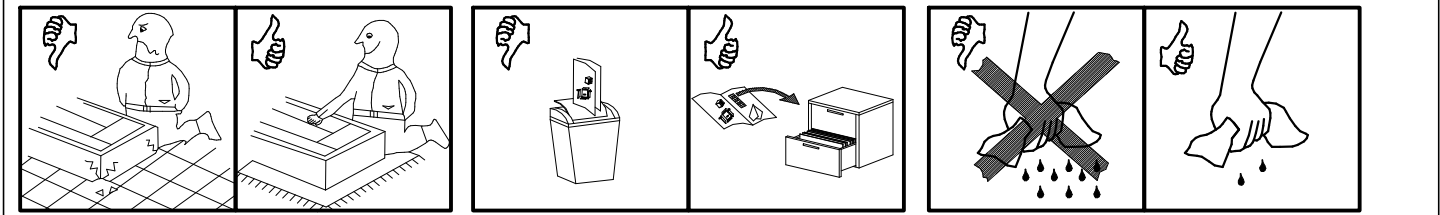
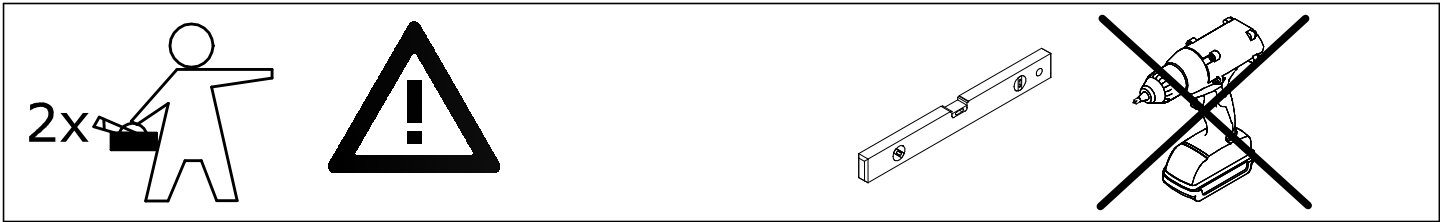
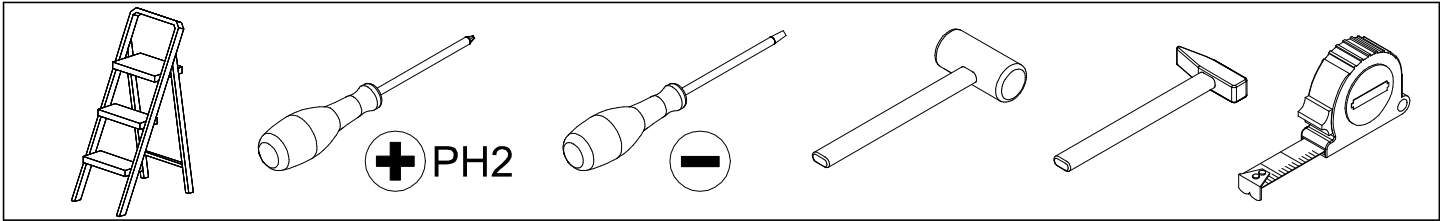

**Service · Assistenza · Dienstverlening · Serwis
Servis · Szerviz · Сервисная служба · Сервис · Serwis · Servis**

Name · Nom · Nome · Naam ·
Nazwa · Jméno · Názov · Név ·
Denumire · Isim · Название



**TALLIN /
TULUZA**

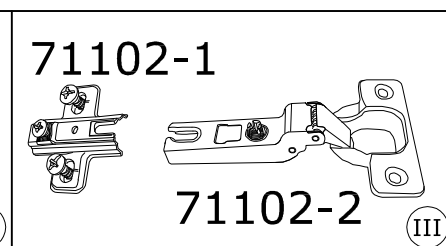
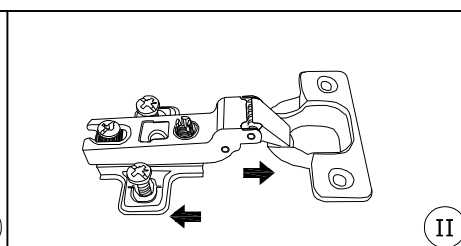
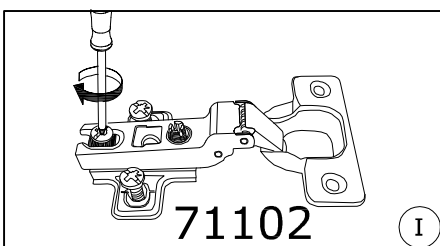
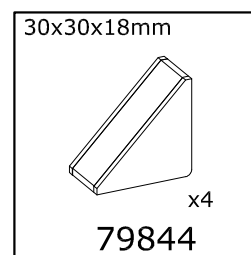
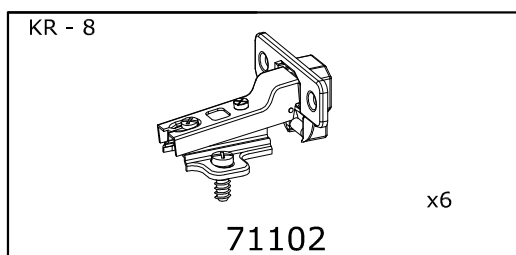
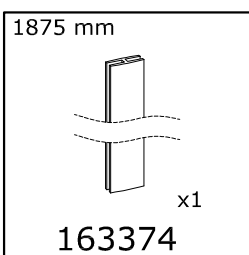
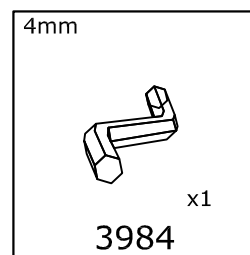
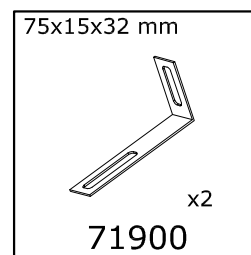
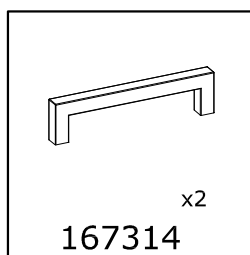
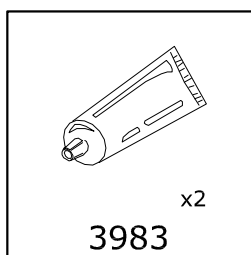
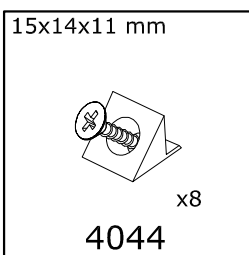
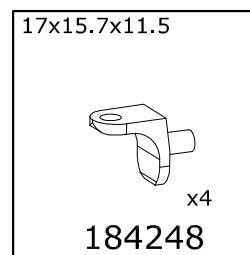
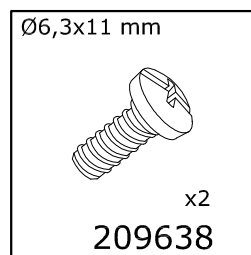
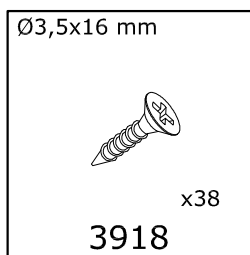
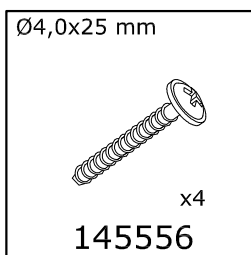
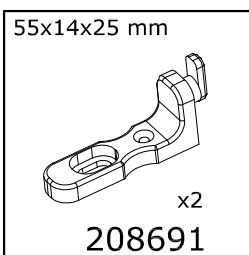
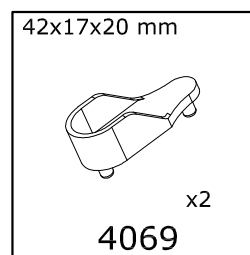
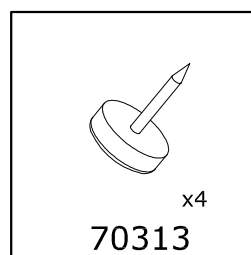
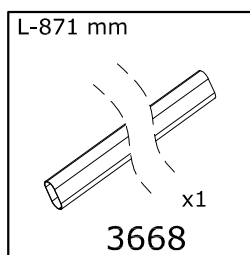
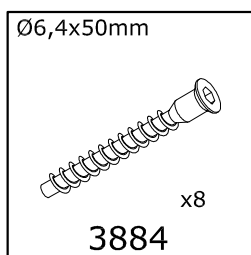
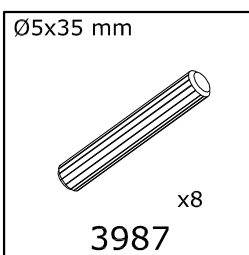
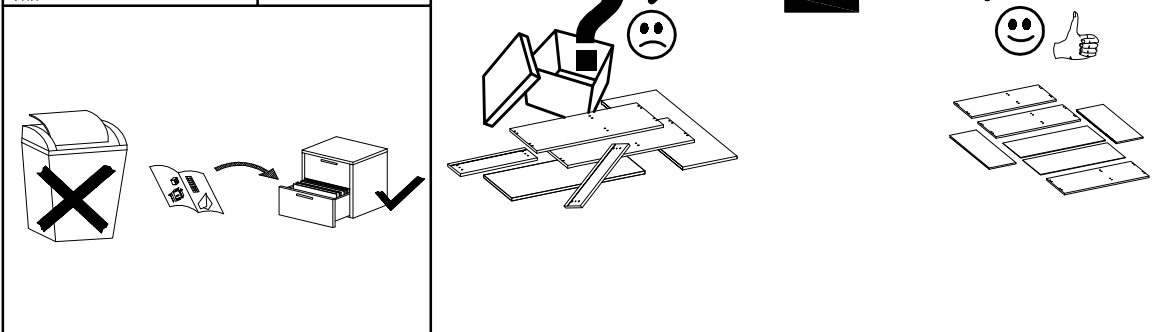

Typ · Type · Tip · Tipus · Tipo ·
Тип

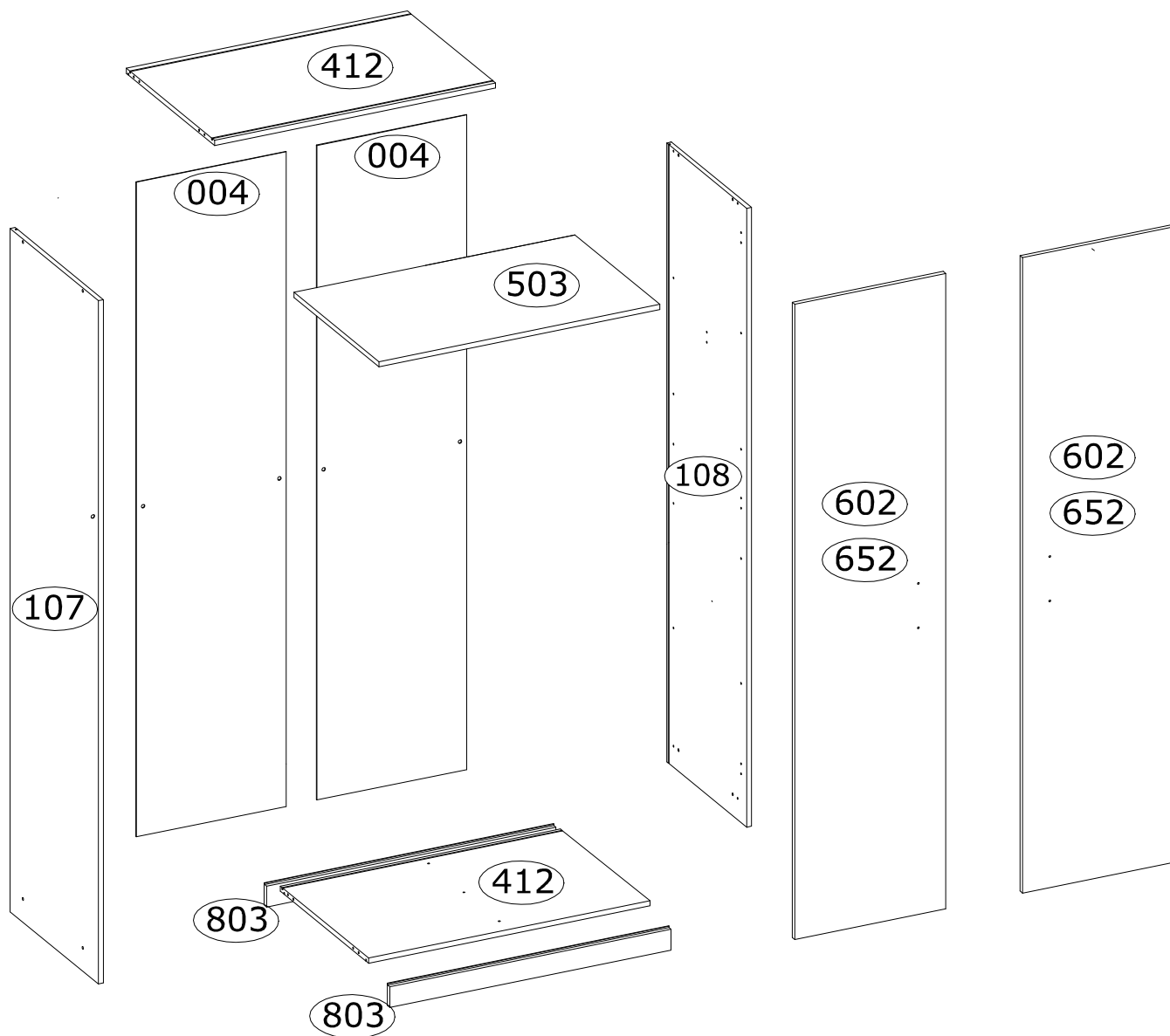
02





TALLIN / TULUZA					
#					
503	879	500	15	1	1/2
803	879	64	15	2	1/2
412	879	519	15	2	1/2
107	1970	520	15	1	2/2
108	1970	520	15	1	2/2
004	1888	443	3	2	1/2

#						
TALLIN	TULUZA					
602	652	1891	444	15/16	2	1/2



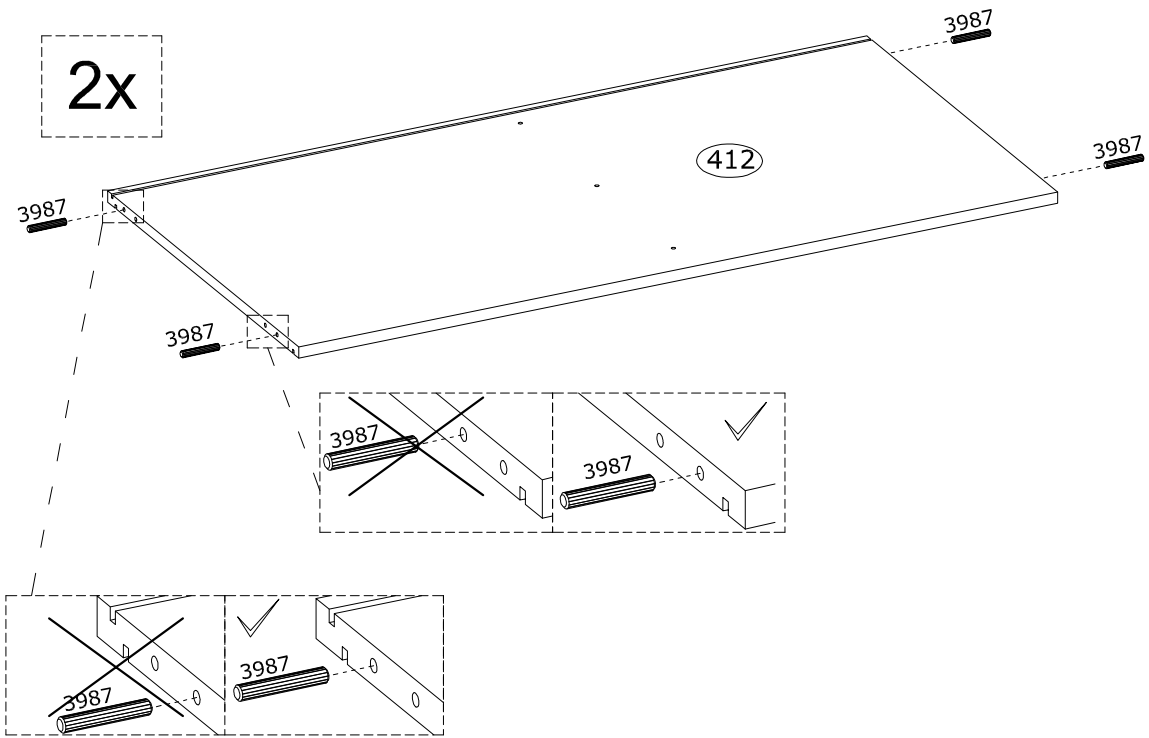

1

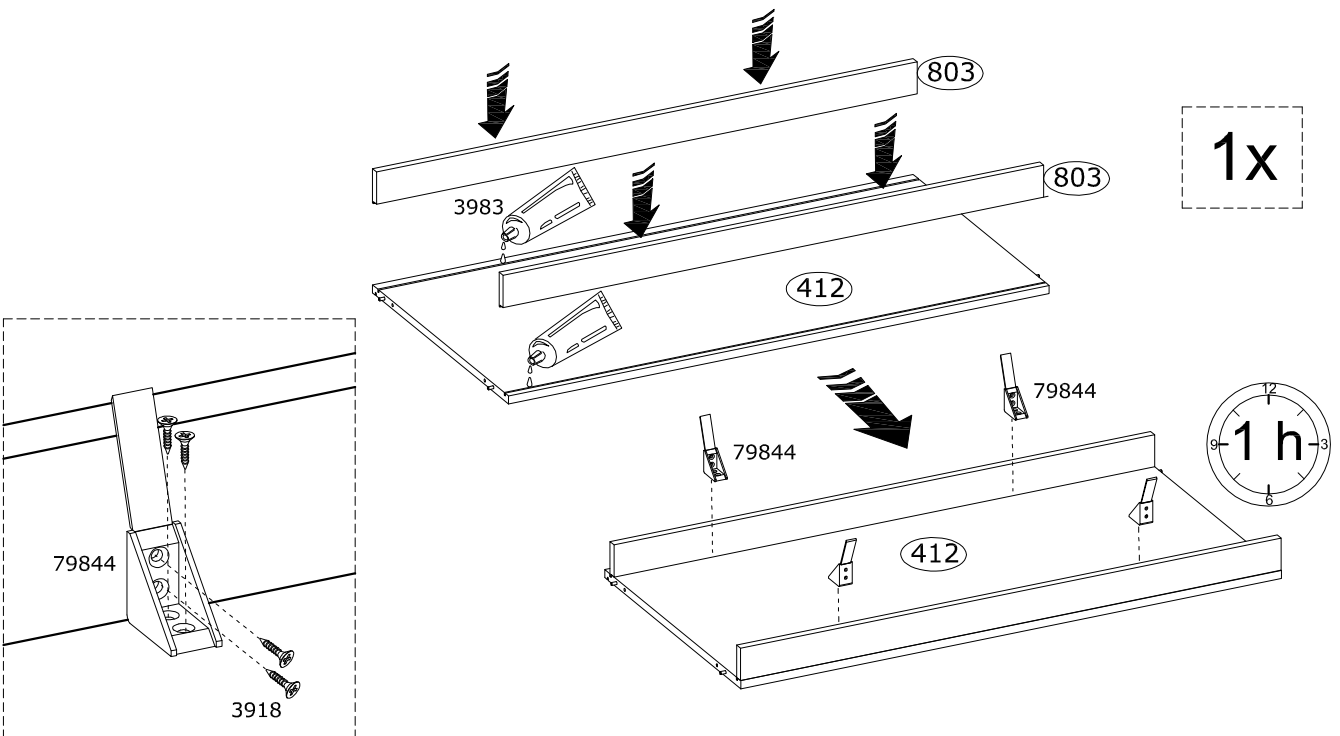
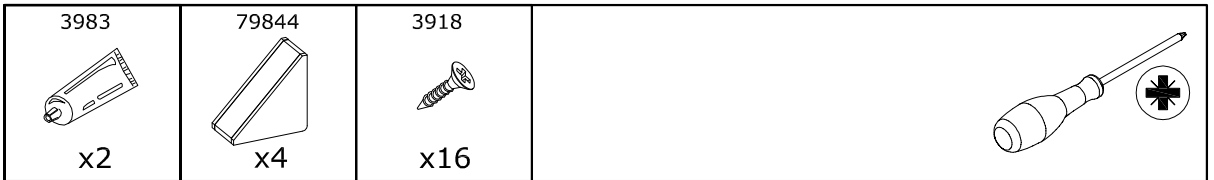

2

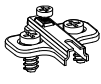



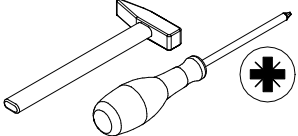

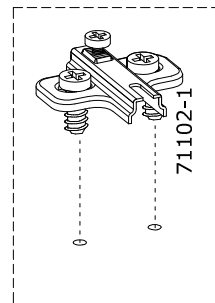
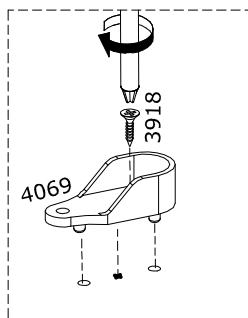
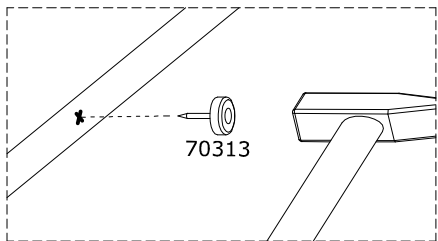
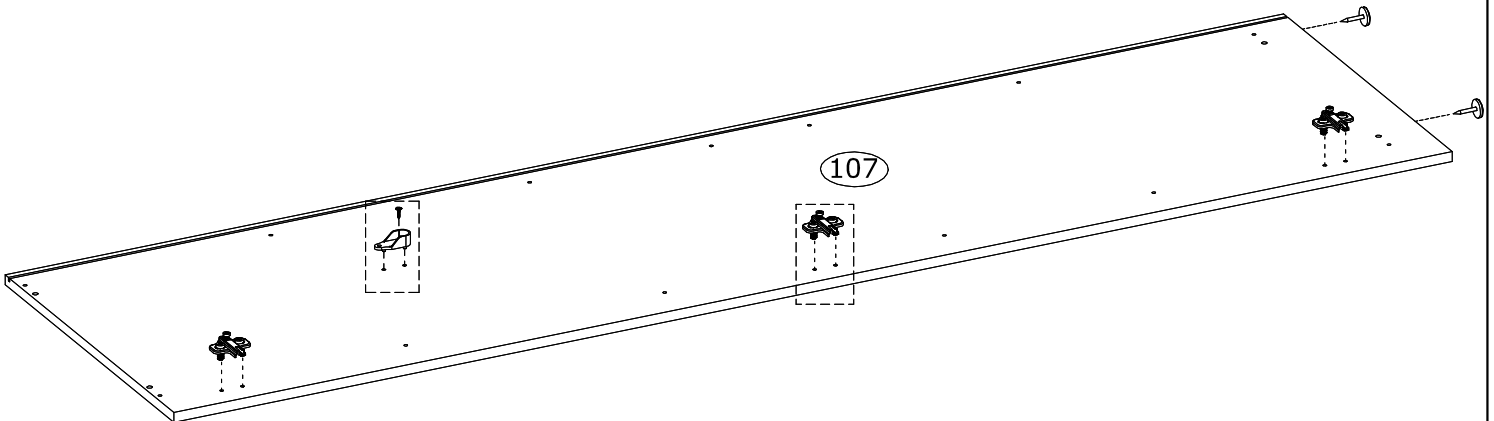
3

71102-1  x3	70313  x2	4069  x1	3918  x1	
--	--	---	---	---

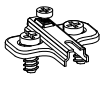

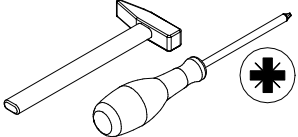

4

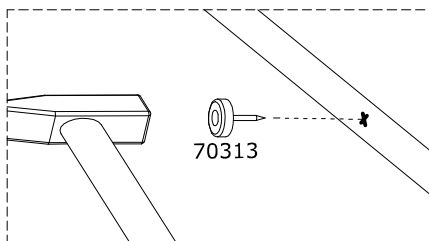
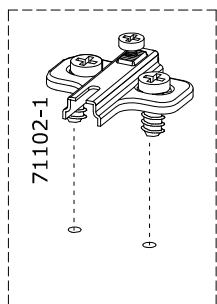
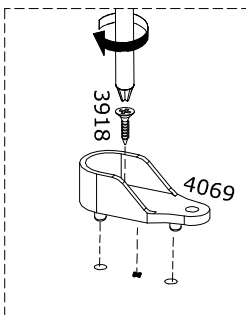
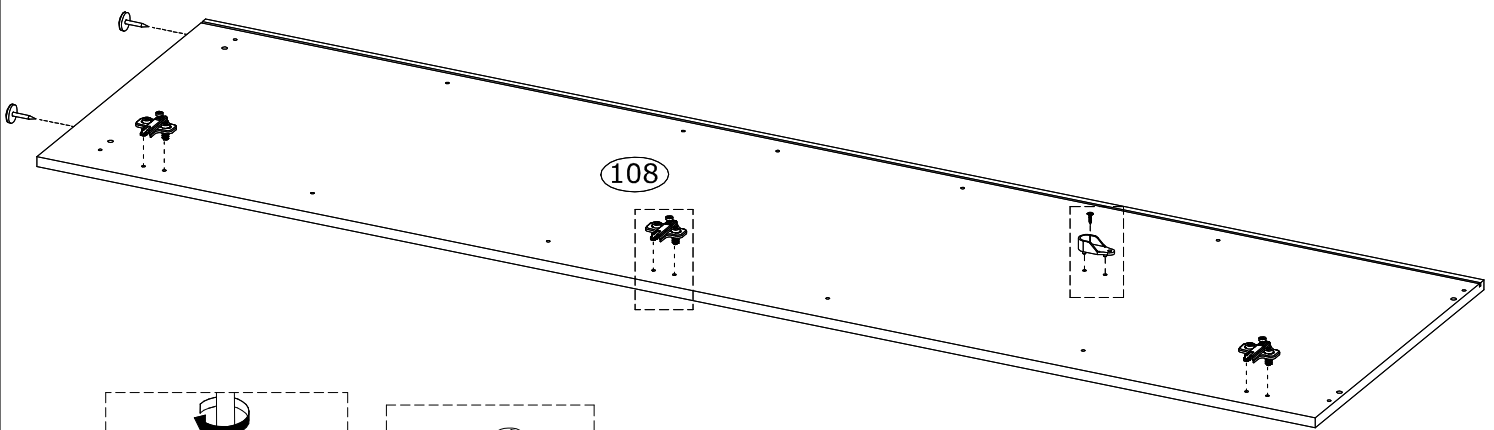
71102-1  x3	70313  x2	4069  x1	3918  x1	
--	--	---	---	---





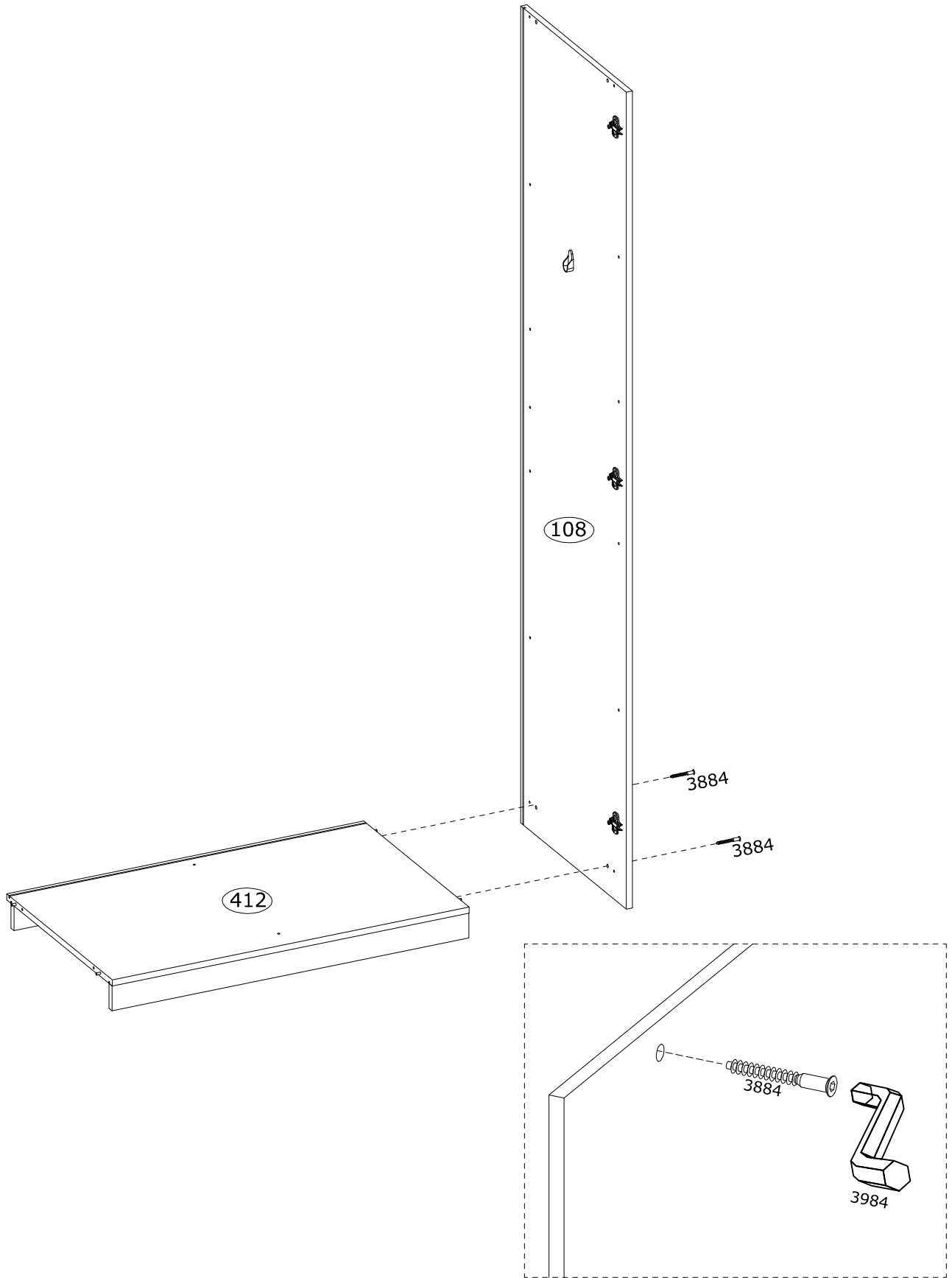

5

<p>3884</p>  <p>x2</p>	<p>3984</p>  <p>x1</p>	 <p>x2</p> 
---	---	---

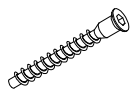





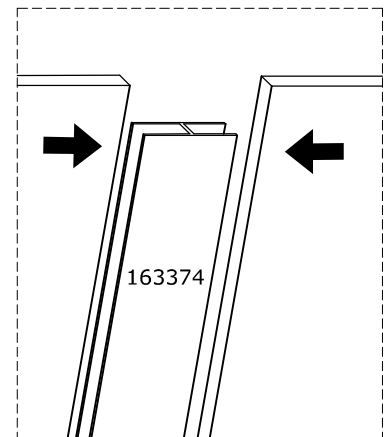
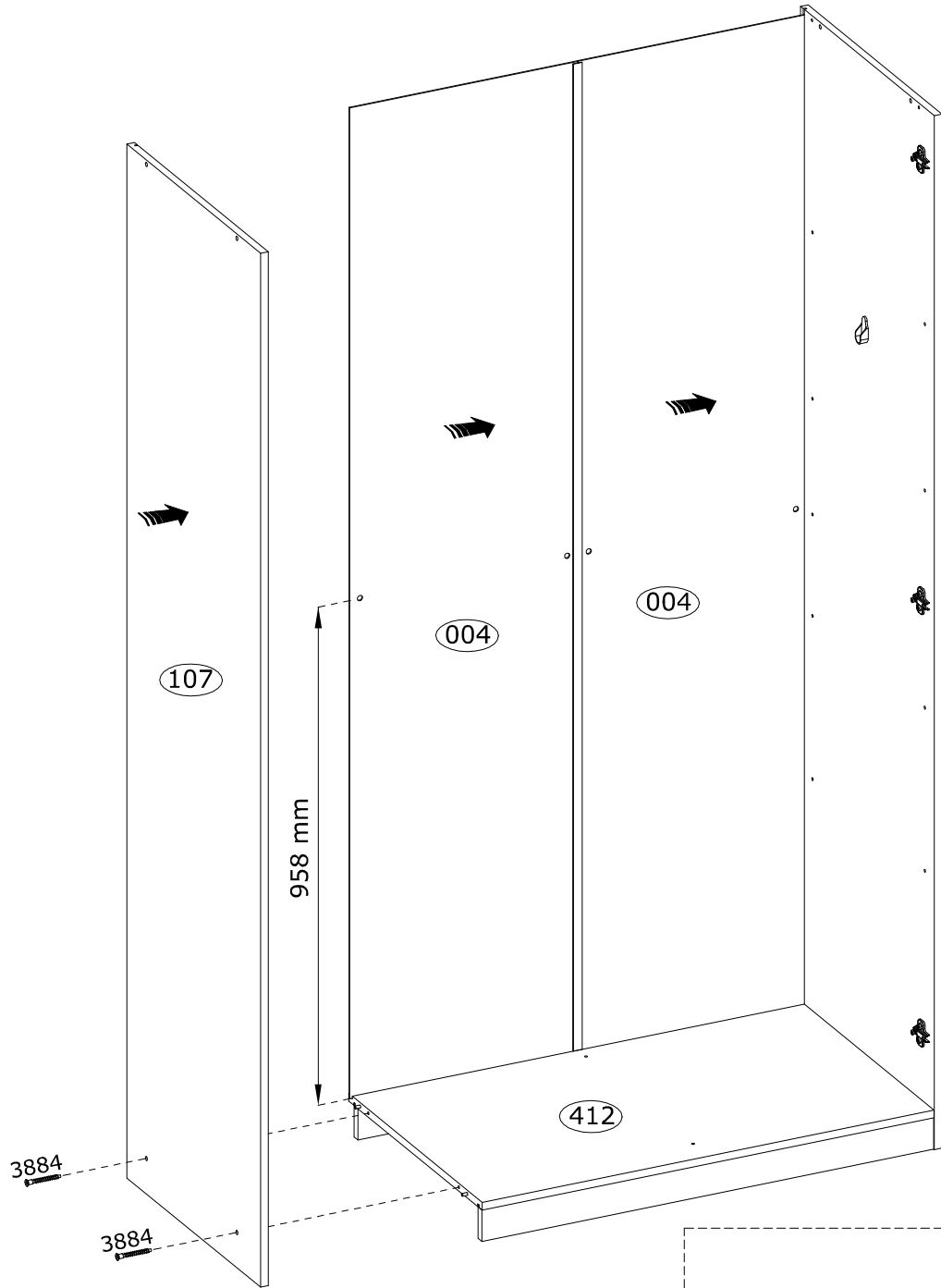

6

<p>3884</p>  <p>x2</p>	<p>3984</p>  <p>x1</p>	<p>163374</p>  <p>x1</p>	 <p>x2</p>	
---	---	---	---	---

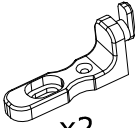

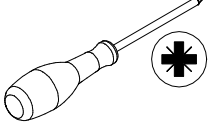

7

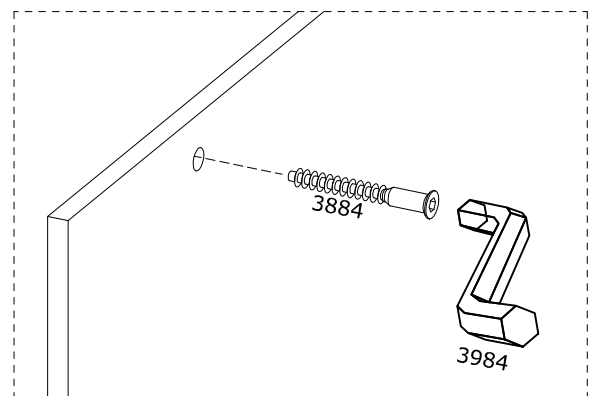
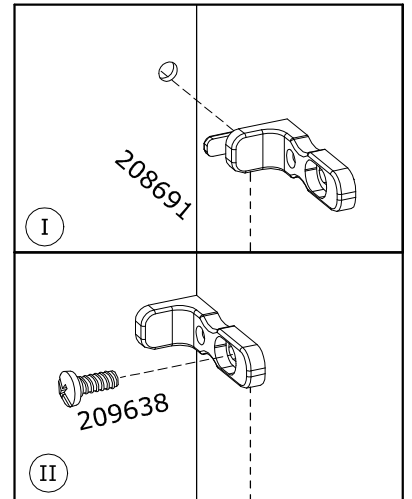
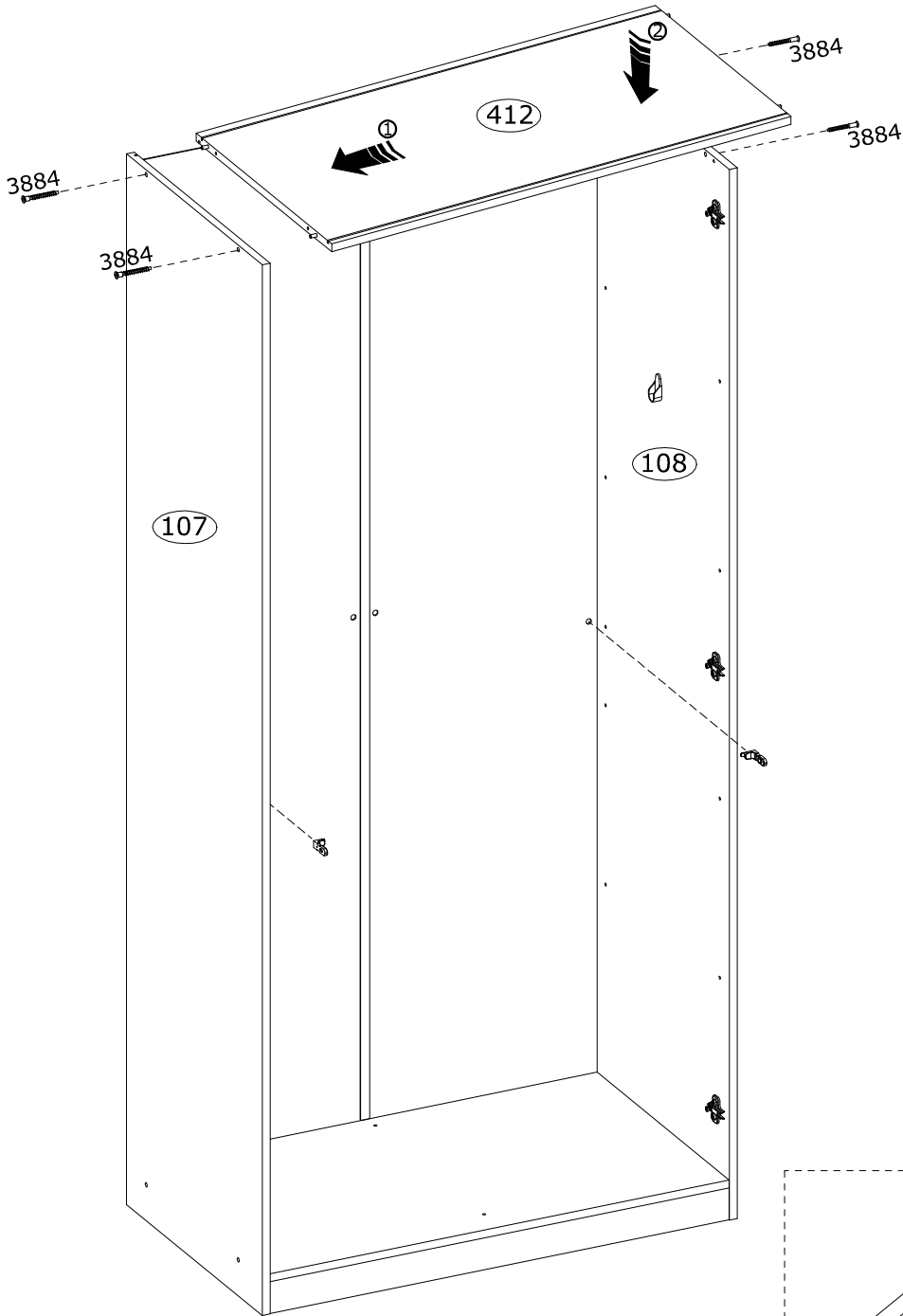
3884  x4	3984  x1	208691  x2	 x2		
209638  x2					

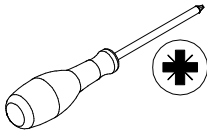

8

<p>184248</p>  <p>x4</p>	<p>3918</p>  <p>x4</p>	<p>3668</p>  <p>x1</p>	
---	---	---	---

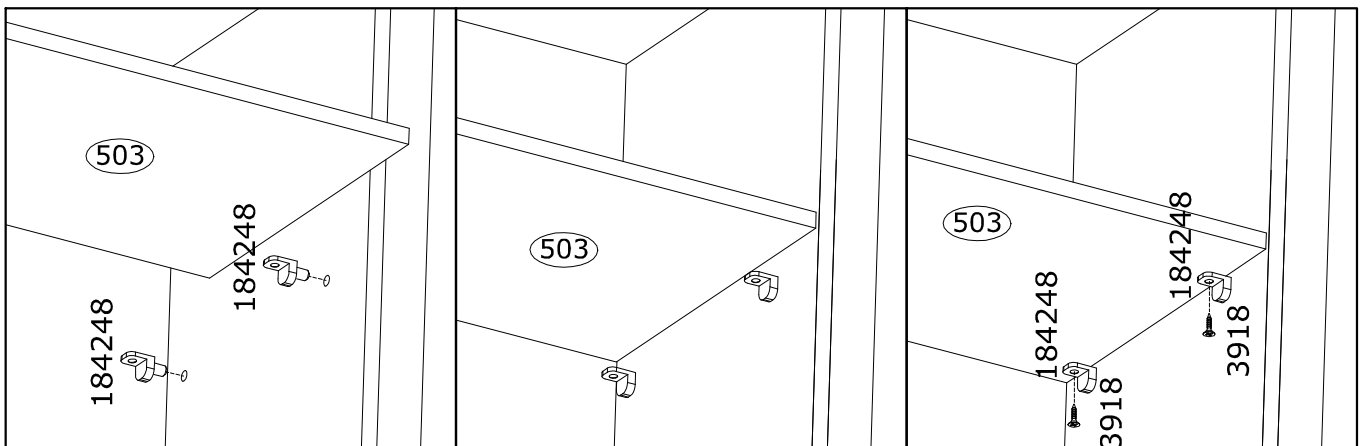
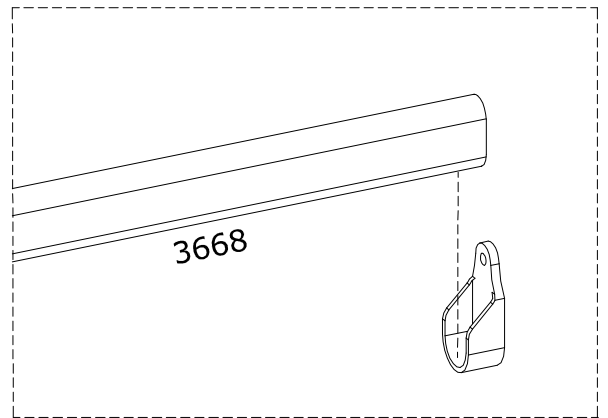
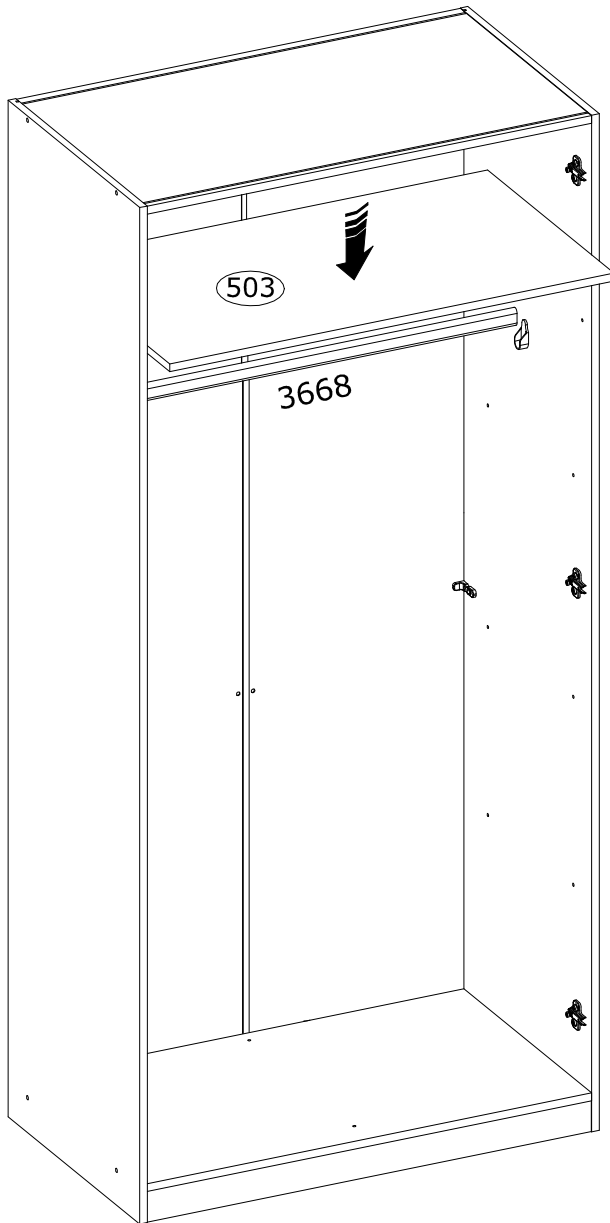

9

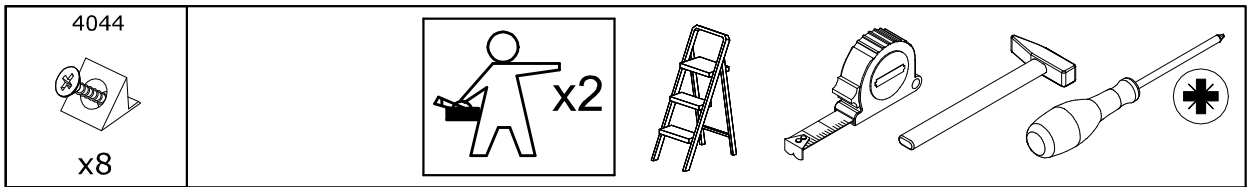

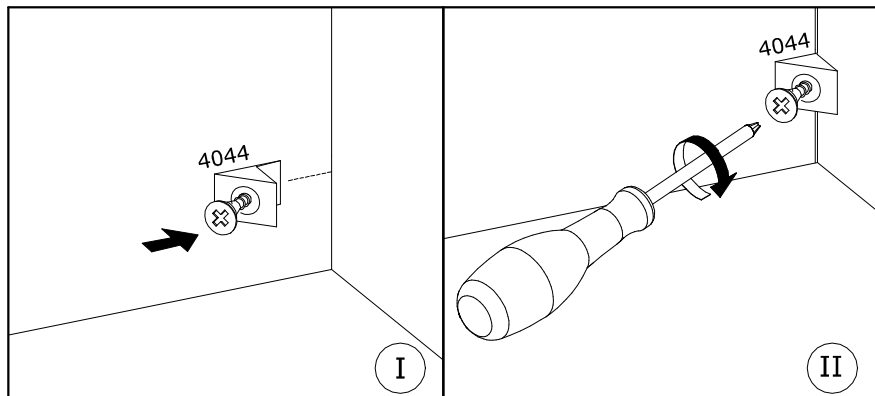
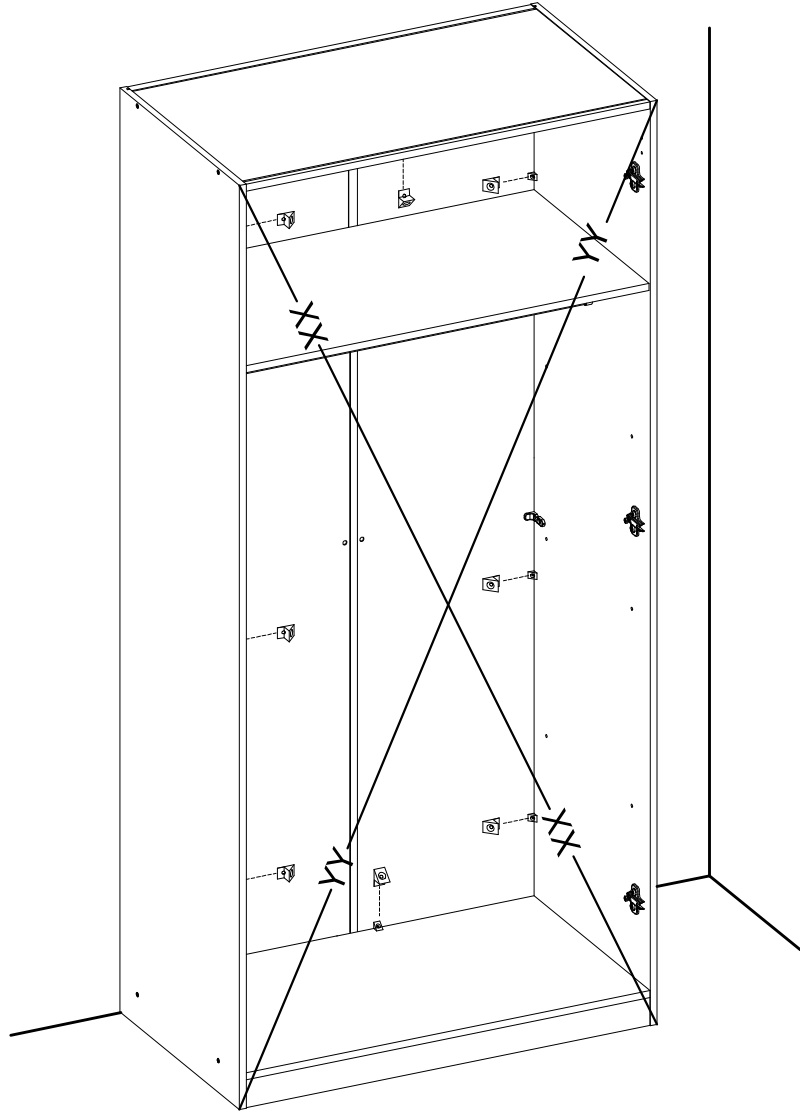

$XX=YY \equiv 90^\circ$

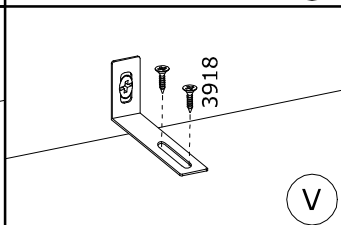
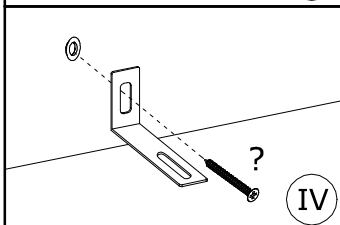
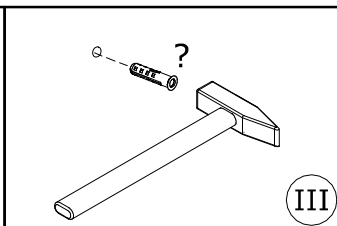
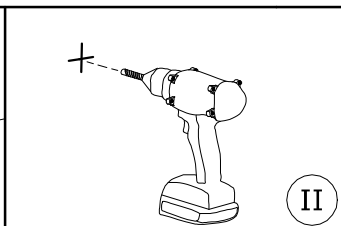
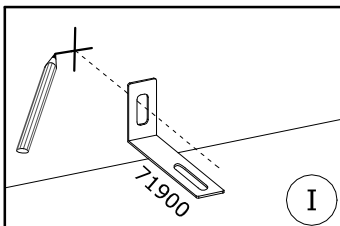
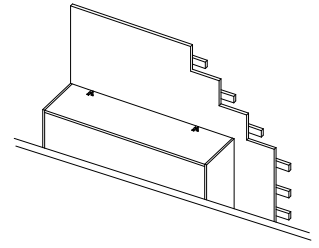
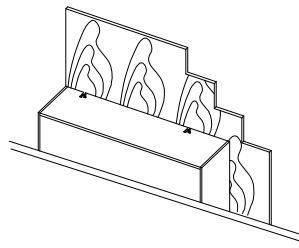
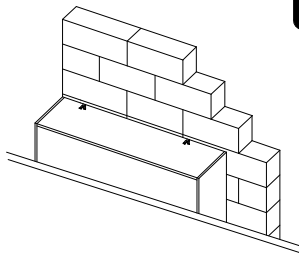
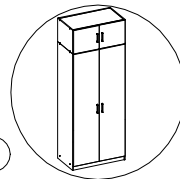
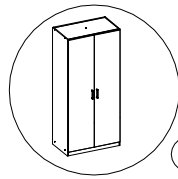
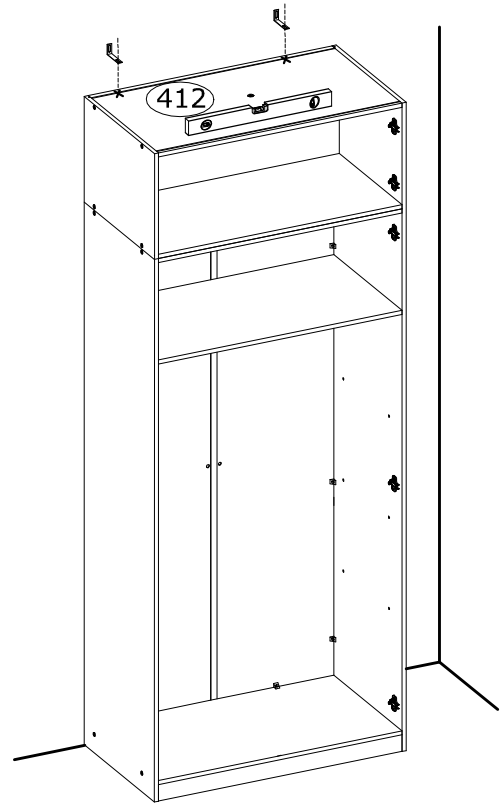
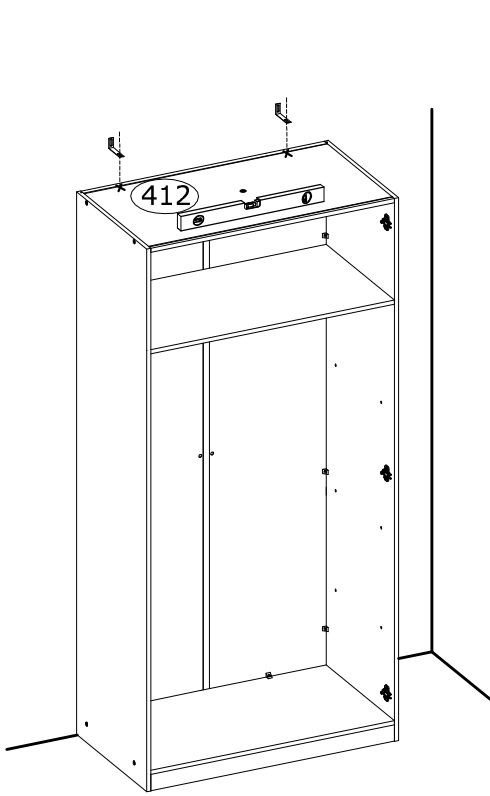
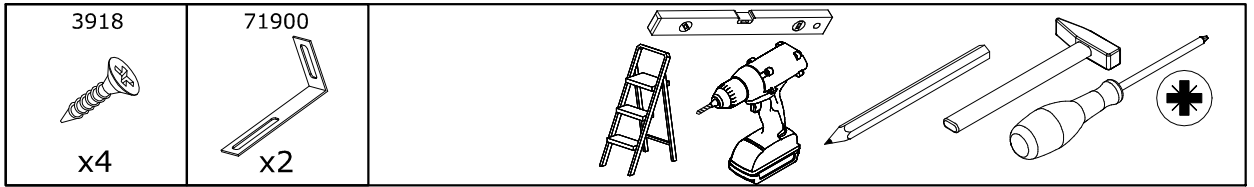

10

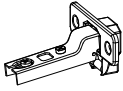

11

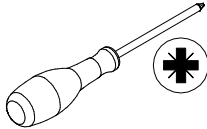
71102-2  x6	3918  x12	
--	--	---

2x

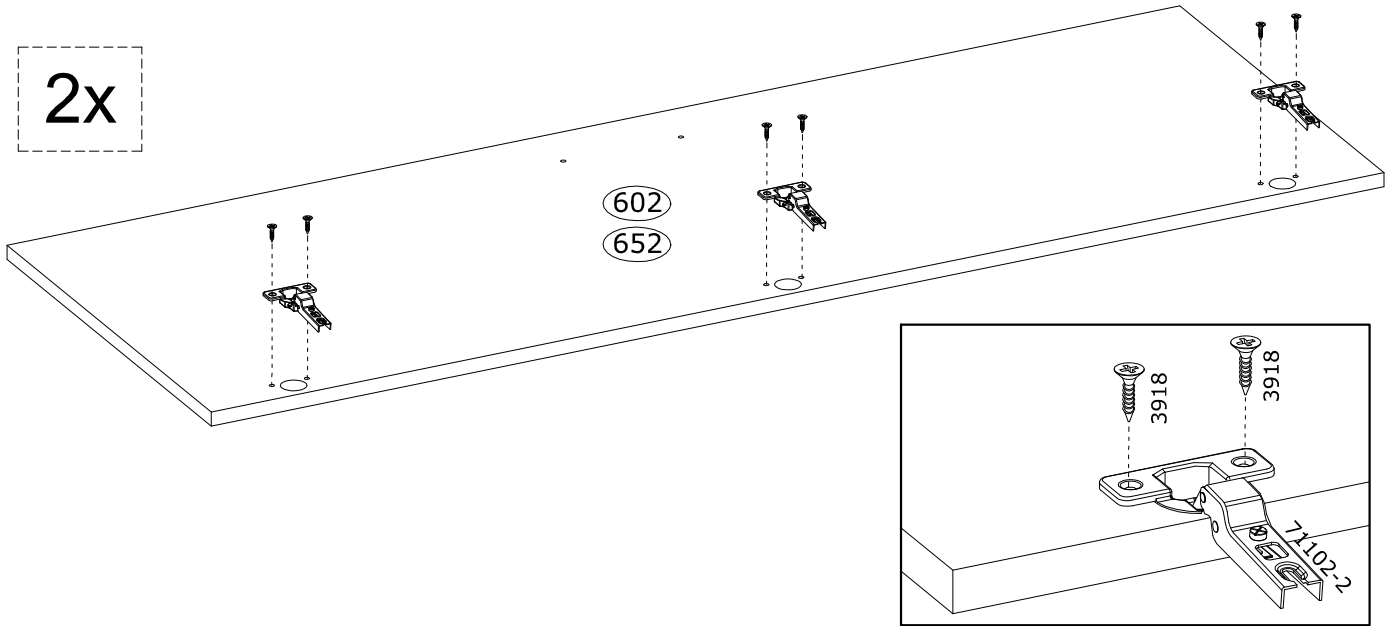

12



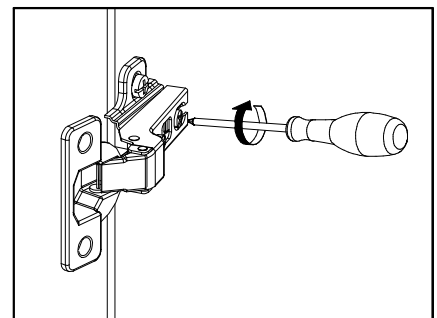
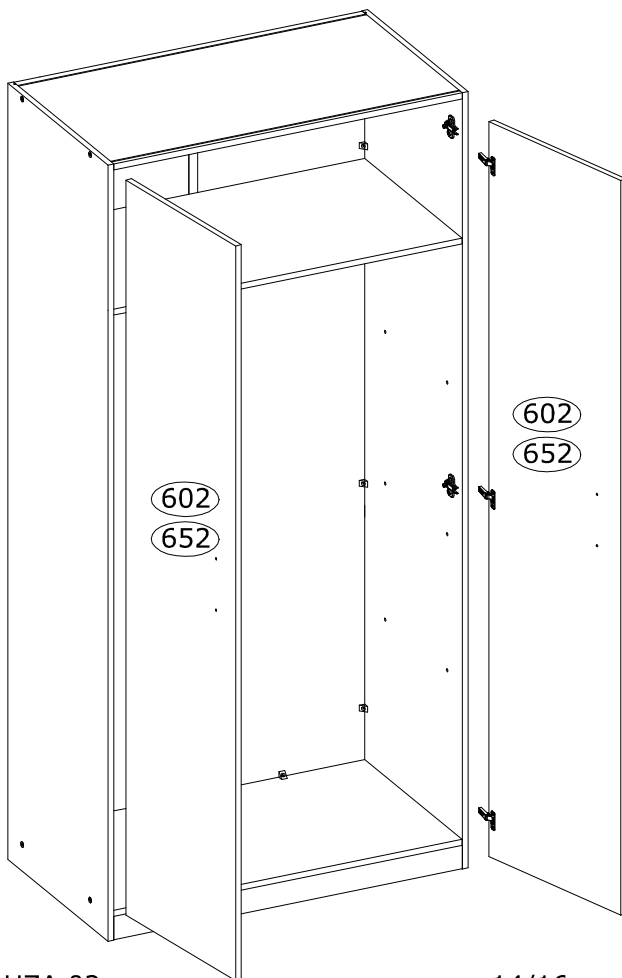

13

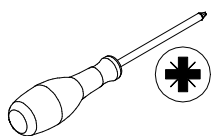
167314  x2	145556  x4	
---	---	---

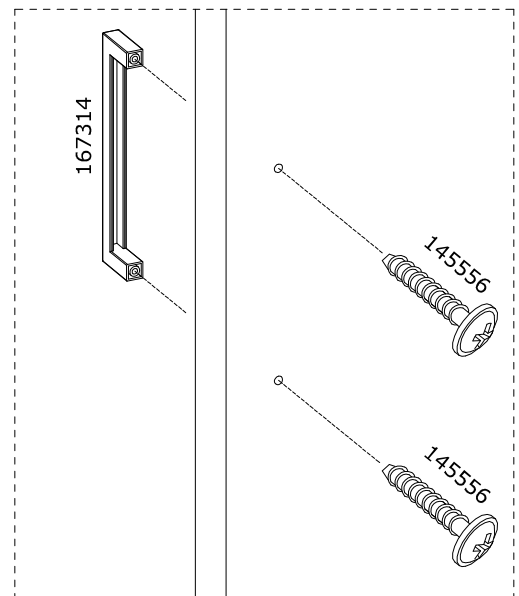
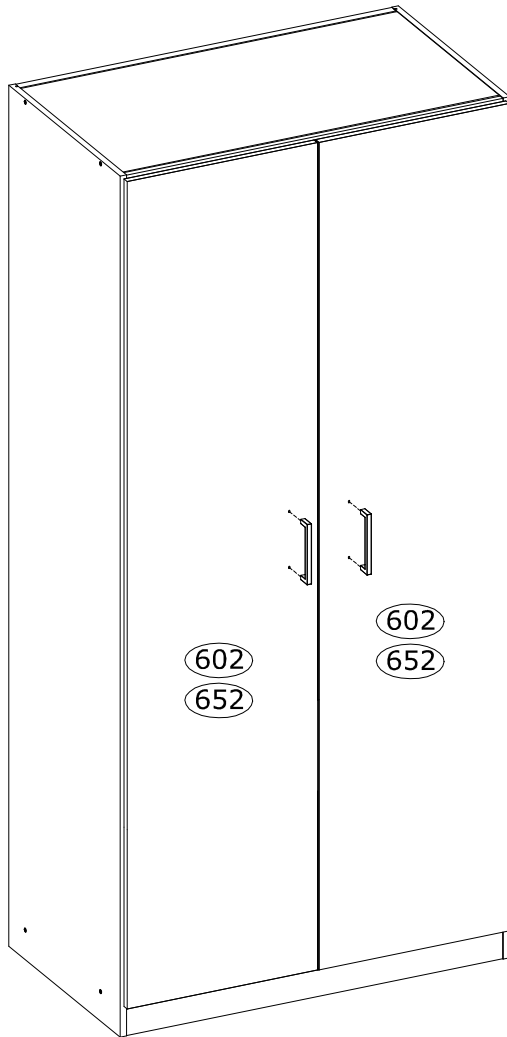

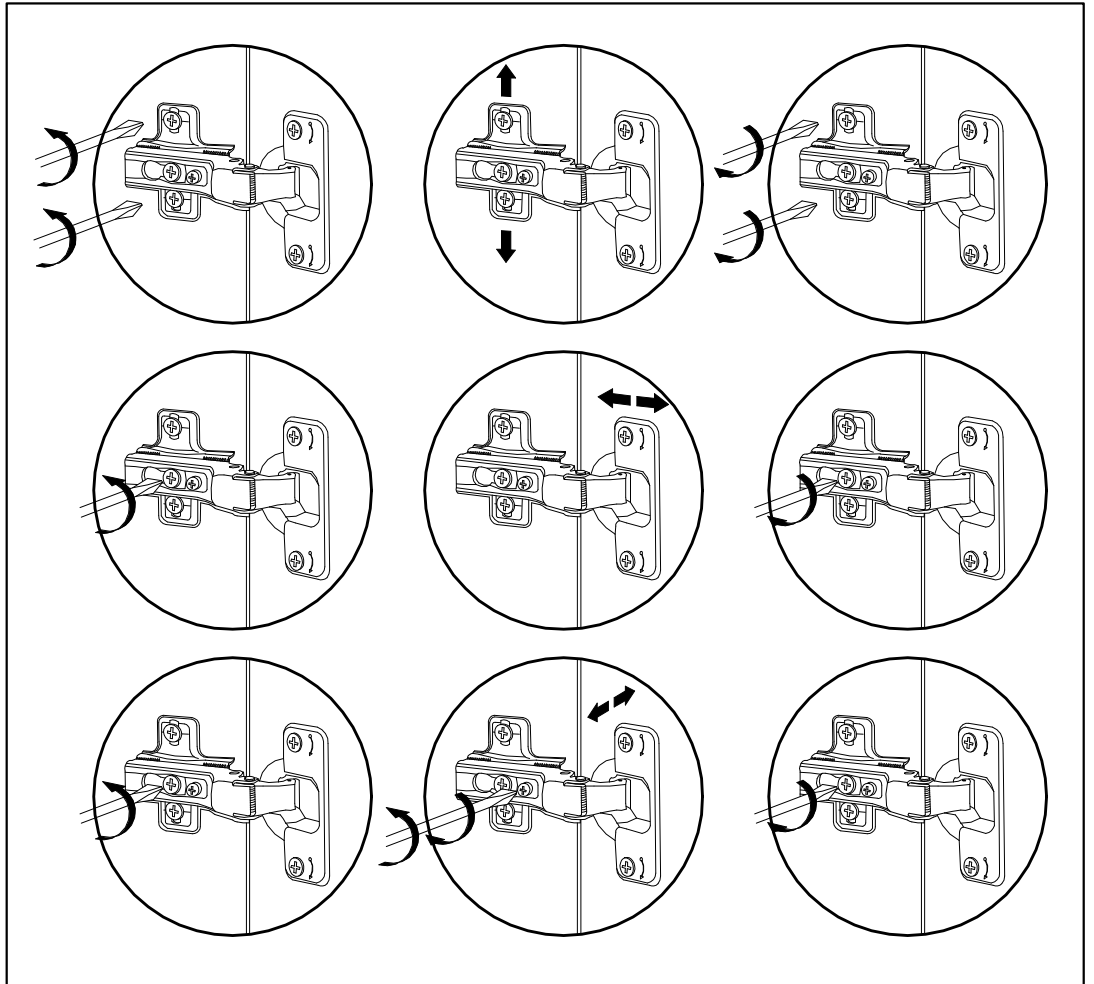
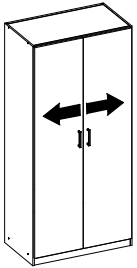
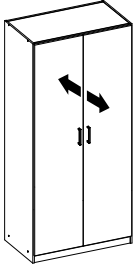
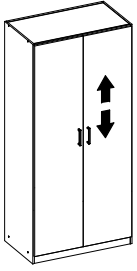

- D** Sicherheits- und Pflegehinweise
- FR** Conseils de sécurité et d'entretien
- NL** Veiligheids- en onderhoudstips
- CZ** Tipy pro bezpečnost a údržbu
- HU** Biztonsági és karbantartási tanácsok
- TR** Güvenlik ve bakım ipuçları
- ES** Instruções de segurança e manutenção
- SRB** Савети за безбедност и одржавање
- SL** Nasveti za varnost in vzdrževanje
- LV** Drošības un apkopes padomi

- GB** Safety and maintenance tips
- IT** Consigli per la sicurezza e la manutenzione
- PL** Wskazówki dotyczące bezpieczeństwa i konserwacji
- SK** Tipy na bezpečnosť a údržbu
- RO** Sfaturi de siguranță și întreținere
- RU** Советы по безопасности и обслуживанию
- PT** Instruções de segurança e manutenção
- HR** Savjeti za sigurnost i održavanje
- LT** Saugos ir priežiūros patarimai
- EE** Ohutus- ja hooldusnõuanded

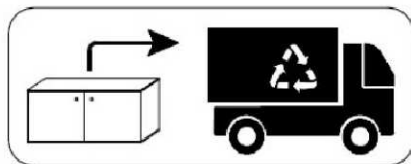
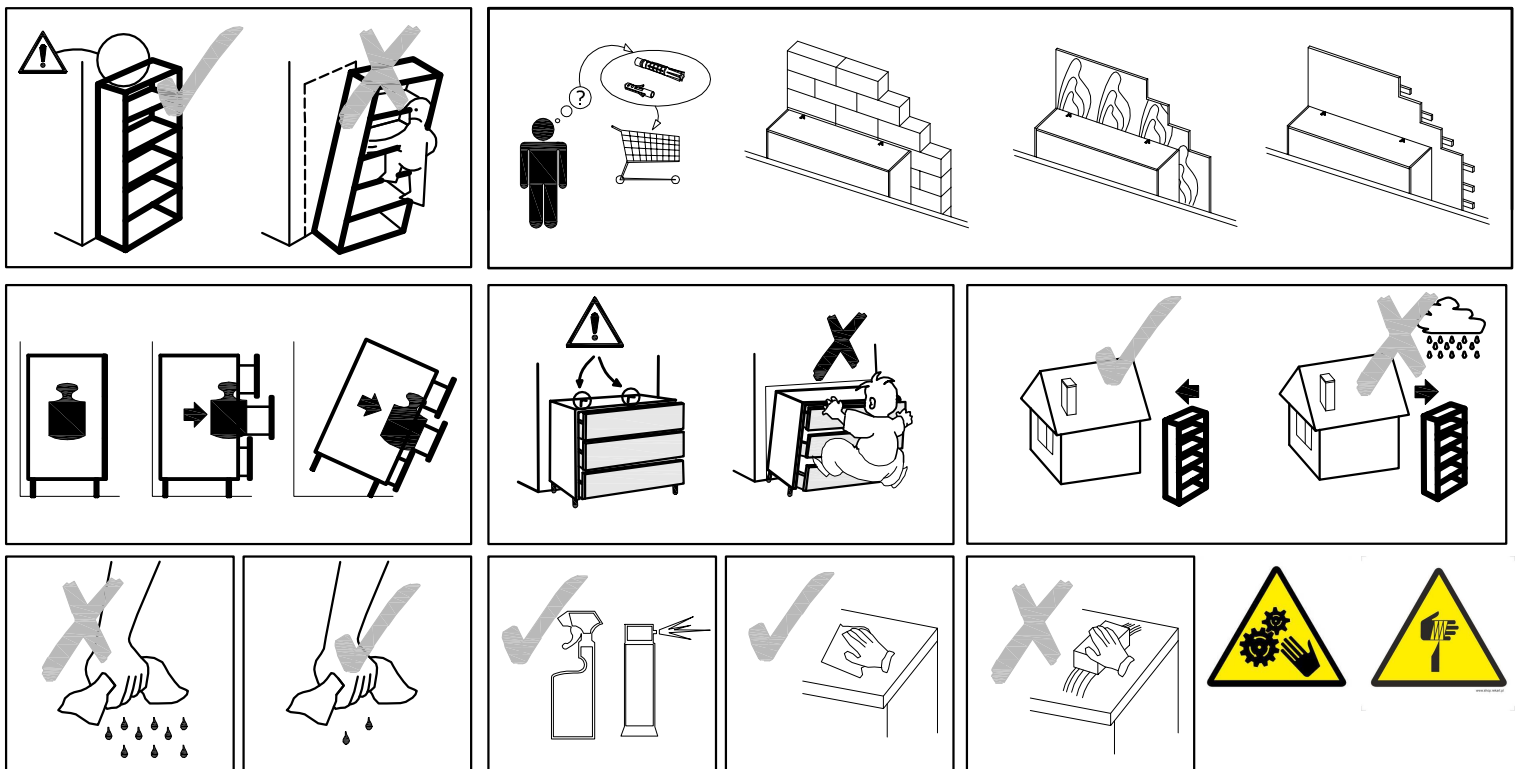

TALLIN

62

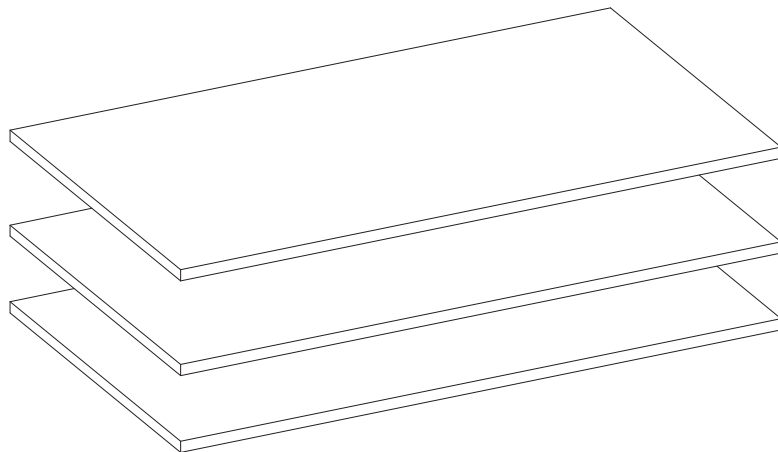
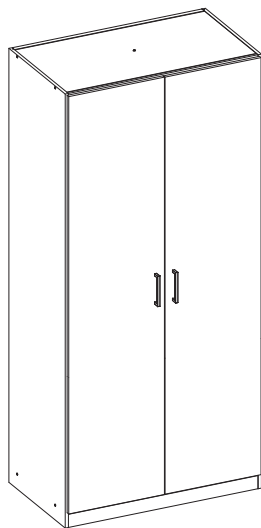

- | | | |
|---|--|---|
| D Montageanleitung
Regale >Tallin< | GB Assembly instructions
Shelves >Tallin< | SRB Упутства за инсталацију
Полуце >Tallin< |
| FR Notice de montage
Étagères >Tallin< | IT Istruzioni di montaggio
Scaffali >Tallin< | HR Upute za instalaciju
Police >Tallin< |
| NL Handleiding voor de montage
Planken >Tallin< | PL Instrukcja montażu
Półki >Tallin< | SL Návod na montaž
Police >Tallin< |
| CZ Montážní návod
Police >Tallin< | SK Návod na montáž
Poličky >Tallin< | LT Surinkimo instrukcijos
Lentynos >Tallin< |
| HU Szerelési útmutató
Polcok >Tallin< | RO Instrucțiuni de
montaj Rafturi >Tallin< | LV Montāžas instrukcija
Plaukti >Tallin< |
| TR Montaj talinatl
Raflar >Tallin< | RU Инструкция по монтажу
Полки >Tallin< | EE Kokkupaneku juhised
Riiulid >Tallin< |
| ES Instrucciones de montaje
Estantes >Tallin< | PT Instruções de montagem
Prateleiras >Tallin< | |

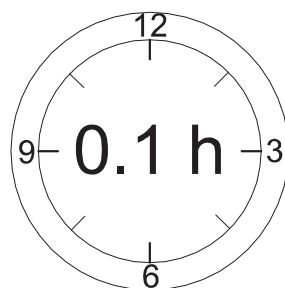
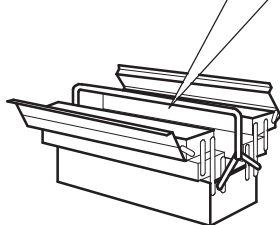
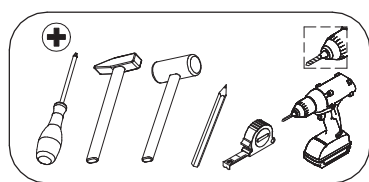

Adresses sur quefairedemesdechets.fr



* 2 7 2 0 9 6 *

D-Ziehen Sie alle Schrauben sowie tragende Verbindungsteile nach ca. 5 Wochen nach, um einedauerhafte Standsicherheit zu gewährleisten.

GB-After approx. 5 weeks, tighten all screws and load-bearing connecting parts to ensure permanent stability.

FR-Resserrez toutes les vis ainsi que les pièces de fixation au bout d'environ 5 semaines pour garantir une sécurité de fixation durable.

IT- Ristringere tutte le viti e giunture dopo ca. 5 settimane, al fine di garantire una durevole solidità.

NL-Draai alle schroeven en ook dragende verbindingstukken na ca. 5 weken nog eens vast, zodateen continue stabiliteit wordt gegarandeerd.

PL-Prosimy po ok. 5 tygodniach dokręcić wszystkie śruby i elementy łączeniowe. Zagwarantuje to Państwu trwałość i stabilność połączeń.

CZ- Dotáhněte všechny šrouby a nosné spojovací díly přibližně po 5 týdnech, aby se zaručila trvalá stabilita.

SK-Po cca 5 týždňoch dotiahnite skrutky, aby bola zaručená ich trvalá stabilita.

HU-Húzza utána - kb. 5 hét múlva - az összes csavart és a teherhordó összekötő-alkatrészeket abiztonság érdekében.

RO-Pentru a asigura o stabilitate de durată, strângeți după cca. 5 săptămâni toate șuruburile, precumși toate elementele portante de legătură.

TR-Tüm vida ve taşıyıcı bağlantı parçalarını kalıcı bir duruş güvenliğini sağlamak için yaklaşık 5 haftasonra tekrar sıkınız.

RU - Подкрутите все болты, а также несущие соединительные детали припл. через 5 недель для обеспечения устойчивости в течение длительного времени.

SRB - Molim vas posle akrokca. 5 nedelja zategnite sve šrafove i pričvršćivače. To ће вам гарантовати трајност и стабилност веза.

HR - Molim vas, nakon cca. 5 tjedana zategnite sve vijke i pričvršćivače. To će vam jamčiti trajnost i stabilnost priključaka.

SL - Pýtame sa po cca. 5 týždňov utiahnite všetky skrutky a upevňovacie prvky. To zaručuje trvanlivosť a stabilitu spojov.

LT - Mes prašome po maždaug. 5 savaites priveržkite visus varžtus ir tvirtinimo detales. Taip užtikrinamas jungčių patvarumas ir stabilumas.

LV - Mēs lūdzam pēc apm. 5 nedēļas, pievelciet visas skrūves un stiprinājumus. Tas garantē savienojumu izturību un stabilitāti.

EE - Küsime pärast ca. 5 nädalat, pingutage kõiki kruvisid ja kinnitusi. See tagab ühenduste vastupidavuse ja stabiilsuse.

ES-Apriete todos los tornillos y elementos de conexión después de aproximadamente 5 semanas. Esto le garantizará la durabilidad y estabilidad de sus conexiones.

PT-Por favor, aperte todos os parafusos e elementos de ligação após aproximadamente 5 semanas. Isto garantirá a durabilidade e a estabilidade das suas ligações.

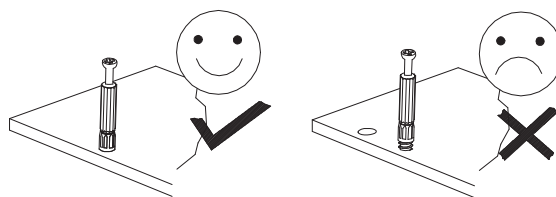

D Bitte nur mit einem Staubtuch oder leicht feuchtem Lappen reinigen. Keine scheuernden Putzmittel verwenden.

GB Please only clean with a duster or a damp cloth. Do not use any abrasive cleaners.

FR Veuillez nettoyer uniquement avec un chiffon à poussière ou un chiffon légèrement humide. Ne pas utiliser de détergent abrasif.

IT Si raccomanda di pulire solo con un panno per la polvere o uno strofinaccio umido. Non utilizzare detersivi abrasivi.

NL Reinig alleen met een stofdoek of een lichtjes vochtige doek. Gebruik geen schurende poetsmid-delen.

PL Czyszczenie należy wykonać wyłącznie za pomocą ściereczki lub lekko nawilżonego ręcznika. Nie stosować środków czyszczących do szorowania.

CZ Čistěte prosím jen prachovkou nebo lehce navlhčeným hadrem. Nepoužívejte drhnoucí čisticí prostředky.

SK Na čistenie používajte len prachovku alebo zľahka navlhčenú utierku. Nepoužívajte žiadne drhnuce čistiace prostriedky.

HU Kérjük, csak portórló kendővel vagy enyhén nedves ronggyal tisztítsa. Ne használjon dörzsztátó tisztítószer.

RO Vă rugăm să utilizați la curățare exclusiv o cârpă de șters praful sau o cârpă ușor umezită. Nu utilizați substanțe de curățat abrazive.

TR Lütfen sadece bir toz beziyle veya hafif nemli yumuşak bir bezle siliniz. Aşındırıcı temizlik malze-meleri kullanmayınız.

RU Для чистки используйте, пожалуйста, тряпку для пыли или слегка влажную ветошь. Не использовать абразивные чистящие средства.

SBR Чишћење треба обавити само крпом или благо влажним пешкиром. Немојте користити средство за чишћење рибања.

HR Čišćenje treba obaviti samo krpom ili blago navlaženim ručnikom. Ne koristite sredstva za čišćenje ribanja.

SL Čistenie by sa malo vykonávať len handričkou alebo ľahko navlhčeným uterákom. Nepoužívajte čistiace prostriedky na drhnutie.

LT Valyti galima tik šluoste arba lengvai sudrėkintu rankšluosčiu. Nenaudokite šveičiamųjų valiklių.

LV Tīršana jāveic tikai ar drānu vai viegli samitrinātu dvieli. Neizmantojiet tīršanas līdzekļus.

EE Puhastada tohib ainult lapiga või kergelt niisutatud rätikuga. Ärge kasutage puhastusvahendeid.

ES La limpieza debe realizarse únicamente con un paño o una toalla ligeramente humedecida. No utilice productos de limpieza abrasivos.

PT A limpeza deve ser feita apenas com um pano ou toalha ligeiramente húmida.

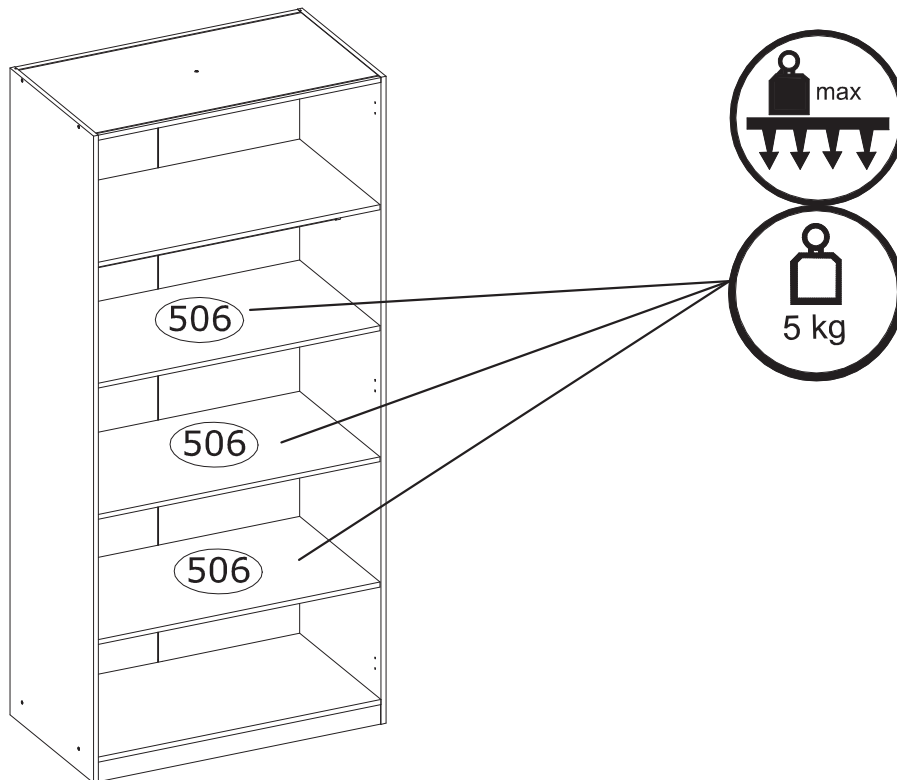
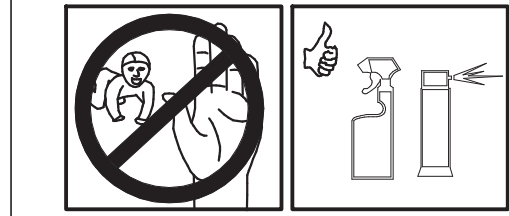
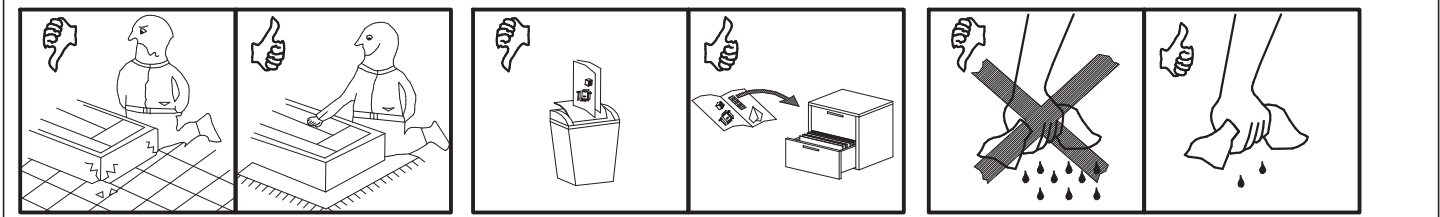
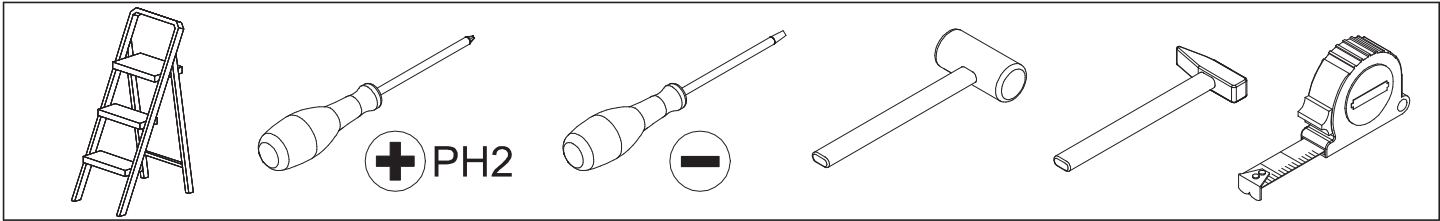

**Service · Assistenza · Dienstverlening · Serwis
 Servis · Szerviz · Сервисная служба · Сервис · Serwis · Servis**

Name · Nom · Nome · Naam · Nazwa · Jméno · Názov · Név · Denumire · Isim · Название	TALLIN
Typ · Type · Tip · Típus · Tipo · Тип	62

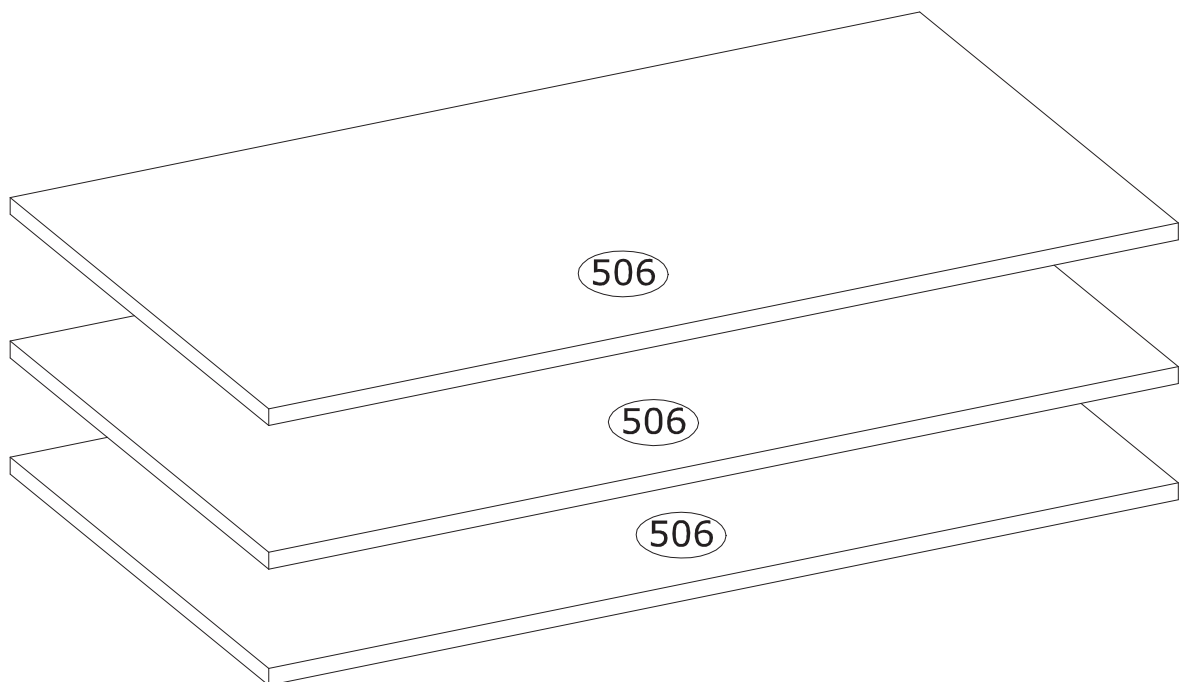
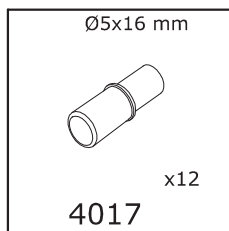
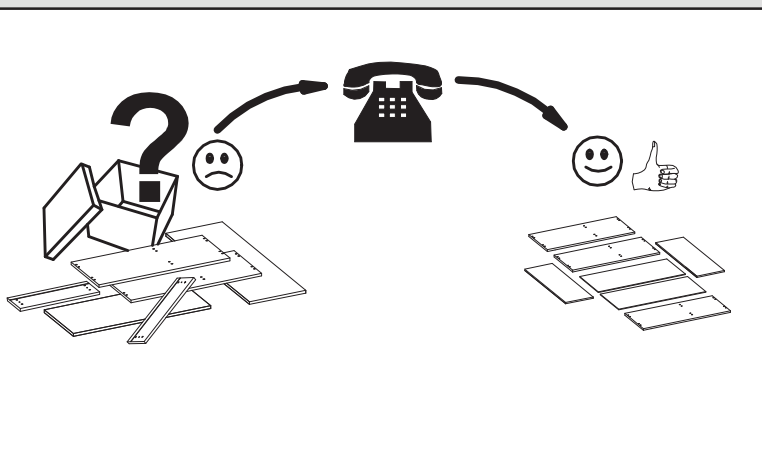
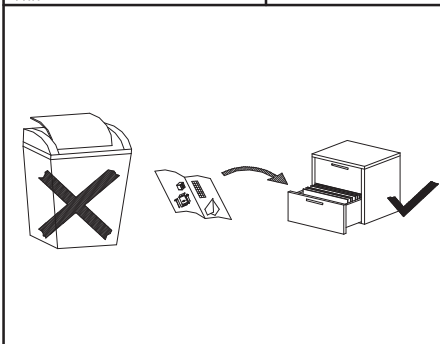

TALLIN					
element	dimension			qte	colli
	length	width	height		
506	879	500	16	3	1/1

1

4017  x12	
--	---

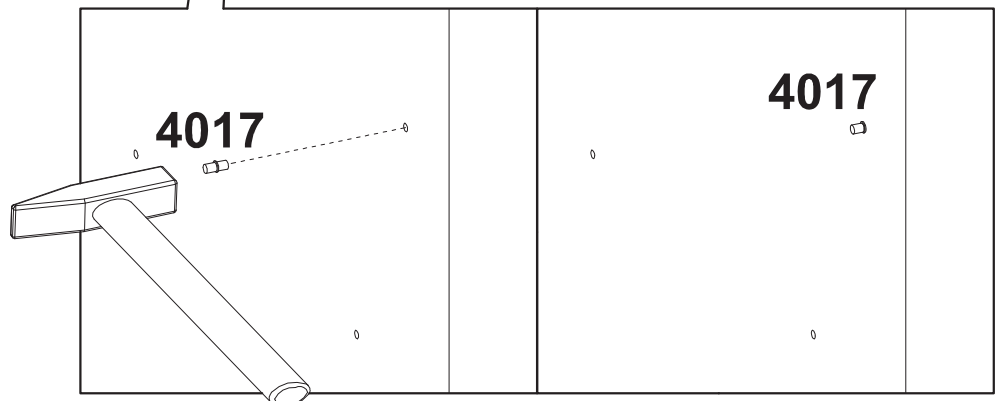
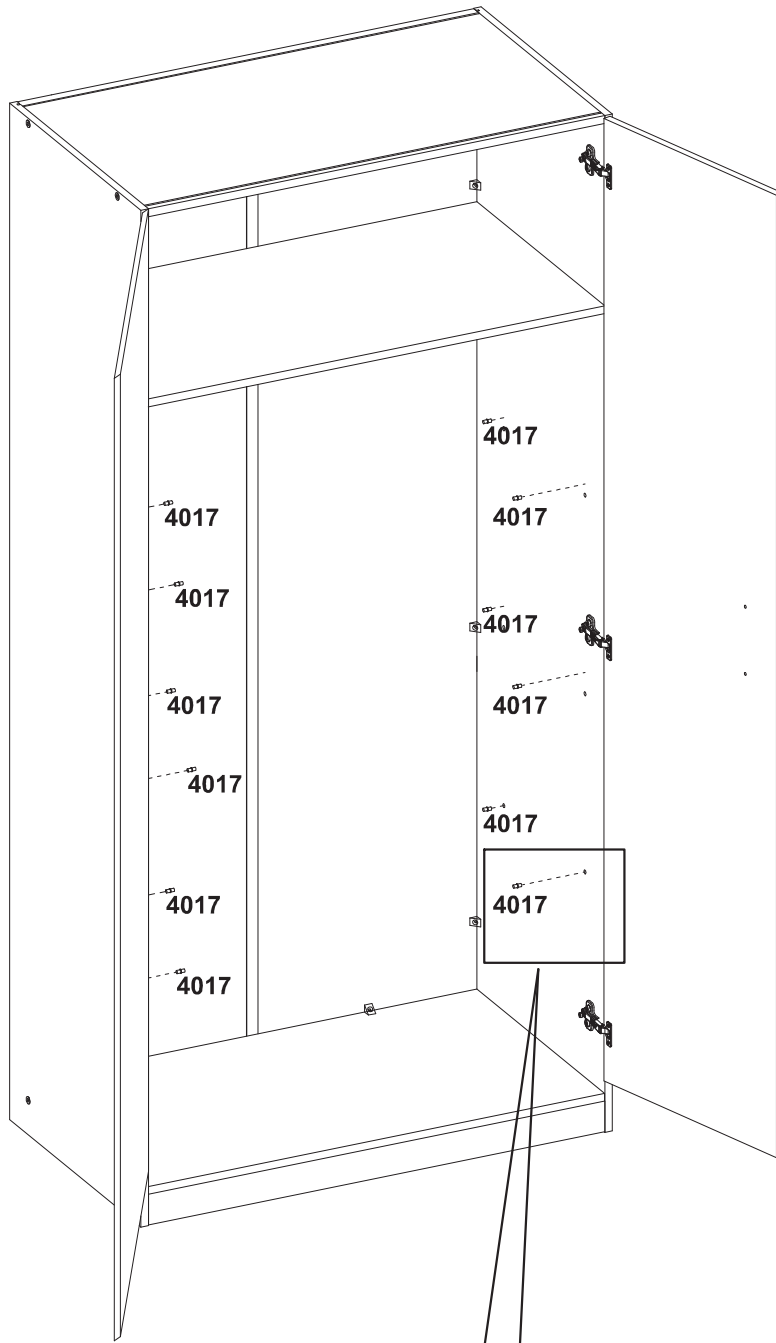

2

