



PL -Montaż powinnien być przeprowadzony zgodnie z instrukcją montażu producenta, w przeciwnym razie może pojawić się niebezpieczeństwo użytkowania.

DE- Die Installation sollte gemäß den Installationsanweisungen des Herstellers erfolgen, da sonst die Gefahr einer Verwendung besteht.

EN- Installation should be carried out in accordance with the manufacturer's installation instructions, otherwise there may be danger of use.

CZ- Instalace by měla být provedena v souladu s instalačními pokyny výrobce, jinak může dojít k nebezpečí použití.

SK- Inštalácia by sa mala vykonávať v súlade s inštaláčnymi pokynmi výrobcu, inak môže existovať nebezpečenstvo použitia.

RU- Установка должна выполняться в соответствии с инструкциями производителя по установке, в противном случае может возникнуть опасность использования.

SRB- Instalaciju treba izvesti u skladu sa uputstvima za ugradnju proizvođača, jer u suprotnom može doći do opasnosti od uporabe.

HR- Instalaciju treba izvoditi u skladu s uputama za ugradnju proizvođača, jer u suprotnom može doći do opasnosti od uporabe.

HU- A telepítést a gyártó telepítési útmutatója szerint kell elvégezni, különben a használat veszélye áll fenn.

**lenart.**

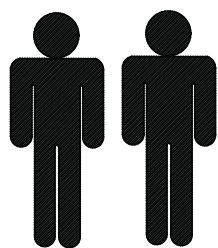
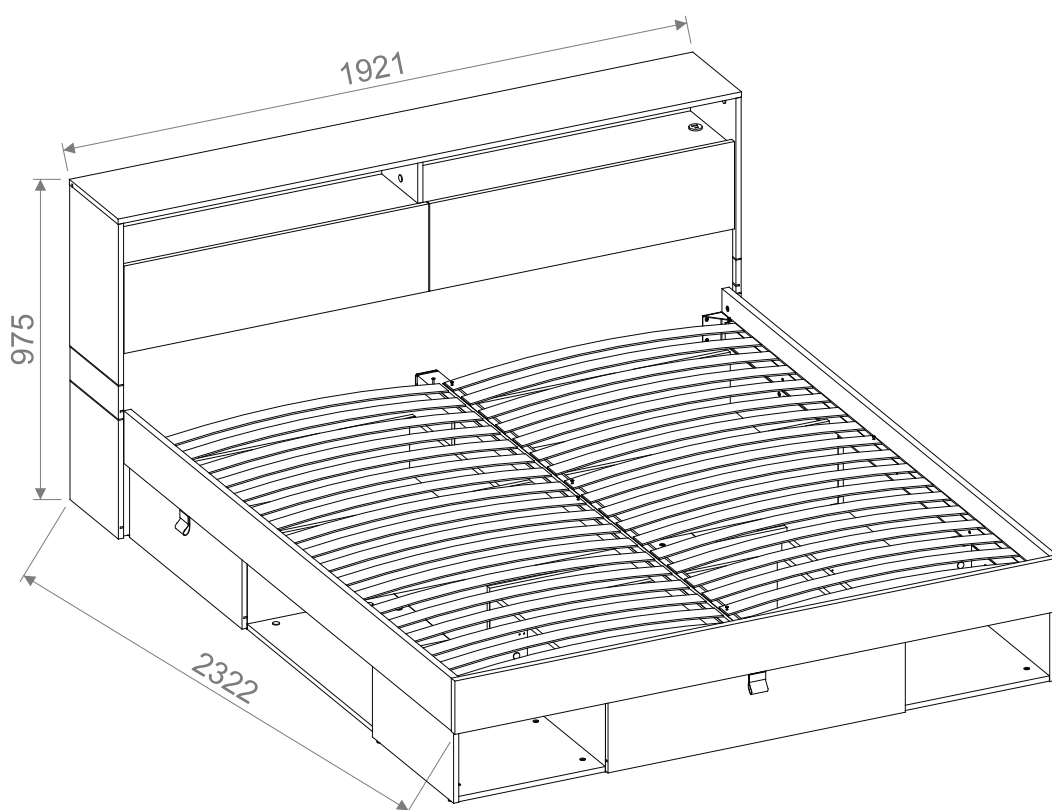

240 min

Company: DIG-NET sp. z o. o. sp. k.  
ul. Krajowa 184a, 63-604 Mroczeń  
e-mail: info@dignet.eu  
NIP:6191953919

Potrzebne narzędzia/ Benötigtes Werkzeug/ Required tools/ Potřebné nástroje/  
Potrebné nástroje/ Необходимые инструменты/ Potreban alat/ Szereléshez szükséges szerszámok

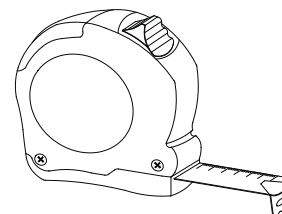
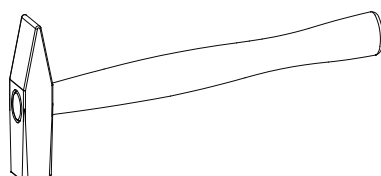
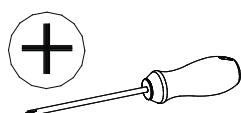

PL - WYMIARY ELEMENTÓW.  
 EN - THE DIMENSIONS OF THE ELEMENTS.  
 DE - ABMESSUNGEN DER ELEMENTE.  
 CZ - ROZMĚRY PRVKŮ.  
 SK - ROZMĚRY PRVKOV.  
 RU - РАЗМЕРЫ ЭЛЕМЕНТОВ.  
 SRB - DIMENZIJE ELEMENATA.  
 HR - DIMENZIJE ELEMENATA.  
 HU - A BÚTORELEMÉK MÉRETEI.

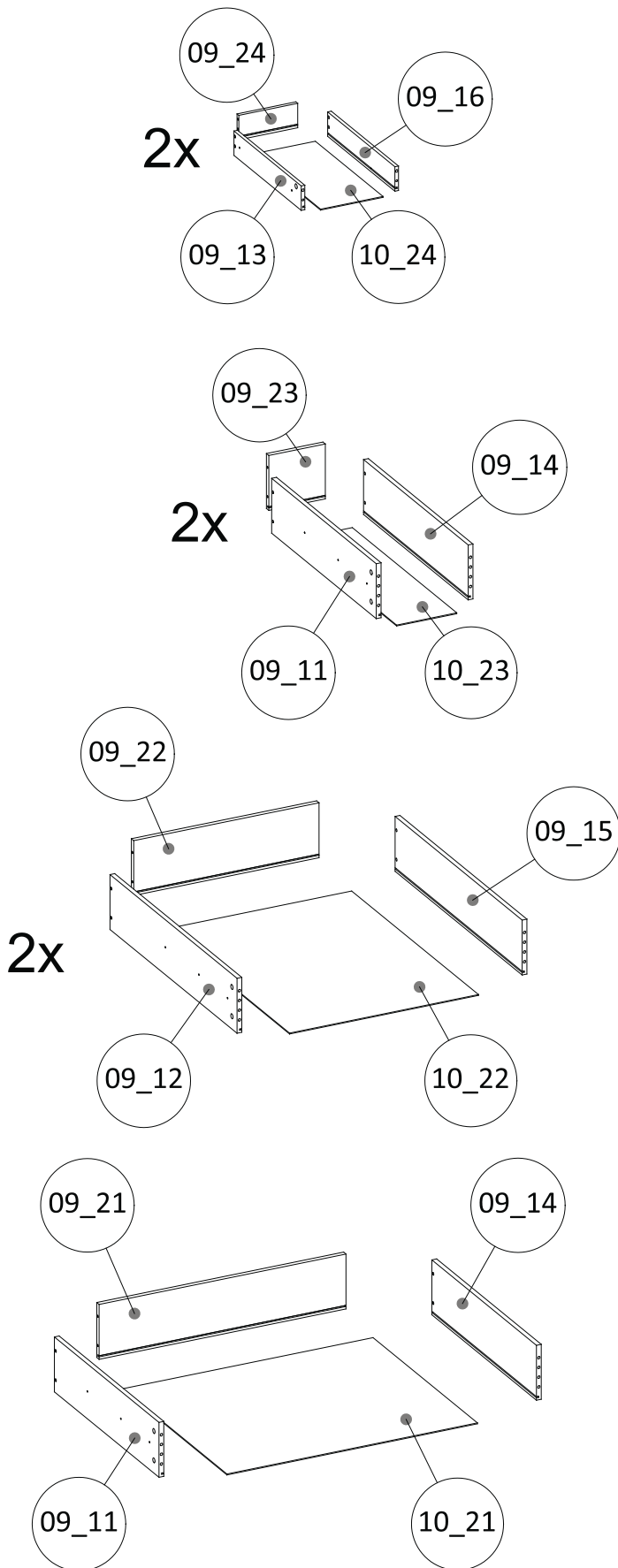
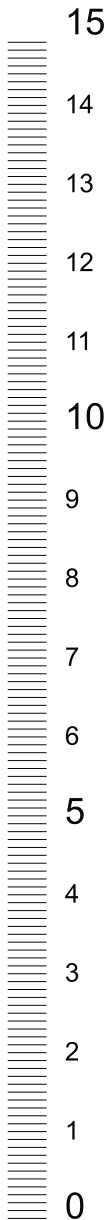

01_01	2020,0	159,0	22,0	1	5/6
01_02	2020,0	159,0	22,0	1	5/6
01_03	500,0	219,0	16,0	1	3/6
01_04	500,0	219,0	16,0	1	3/6
01_05	486,0	300,0	16,0	1	3/6
01_06	486,0	300,0	16,0	1	3/6
02_02	1921,0	300,0	16,0	1	5/6
03_11	1302,0	452,5	16,0	1	2/6
03_12	1302,0	452,5	16,0	1	2/6
03_13	1887,0	264,0	16,0	1	4/6
03_14	1887,0	261,0	16,0	1	4/6
04_11	916,0	270,0	16,0	1	1/6
04_12	247,0	713,0	16,0	1	3/6
04_13	247,0	713,0	16,0	1	3/6
04_15	452,5	230,5	16,0	2	3/6
04_17	1821,0	270,0	16,0	1	5/6
04_18	223,0	245,0	16,0	1	1/6
04_19	150,0	222,0	16,0	1	3/6
07_16	65,0	2004,0	38,0	1	5/6
07_21	884,0	100,0	16,0	1	5/6
07_81	1860,0	60,0	25,0	2	5/6
08_11	939,0	264,0	16,0	1	2/6
08_12	939,0	264,0	16,0	1	2/6
08_21	916,0	211,0	16,0	1	2/6
08_22	693,0	212,0	16,0	1	2/6
08_23	693,0	212,0	16,0	1	2/6
08_24	358,0	298,0	16,0	1	2/6
08_25	358,0	298,0	16,0	1	2/6
08_26	298,0	100,0	16,0	1	1/6
08_27	298,0	100,0	16,0	1	1/6
09_11	700,0	180,0	16,0	3	1/6
09_12	850,0	180,0	16,0	2	1/6
09_13	450,0	80,0	12,0	2	1/6
09_14	700,0	180,0	16,0	3	1/6
09_15	850,0	180,0	16,0	2	1/6
09_16	450,0	80,0	12,0	2	1/6
09_21	826,0	180,0	16,0	1	1/6
09_22	620,0	180,0	16,0	2	1/6
09_23	189,0	180,0	16,0	2	1/6
09_24	197,0	80,0	12,0	2	1/6
10_11	401,0	949,5	3,0	1	4/6
10_12	401,0	949,5	3,0	1	4/6
10_21	838,0	698,5	3,0	1	4/6
10_22	632,0	848,5	3,0	2	4/6
10_23	201,0	698,5	3,0	2	4/6
10_24	209,0	452,5	3,0	2	4/6
13_11	916,0	574,0	16,0	1	3/6
13_21	247,0	100,0	16,0	4	3/6
13_22	549,0	730,0	16,0	1	3/6
13_23	549,0	730,0	16,0	1	3/6
13_31	549,0	70,0	22,0	2	5/6
14_11	1887,0	566,0	16,0	1	4/6
14_21	1867,0	161,0	22,0	1	5/6

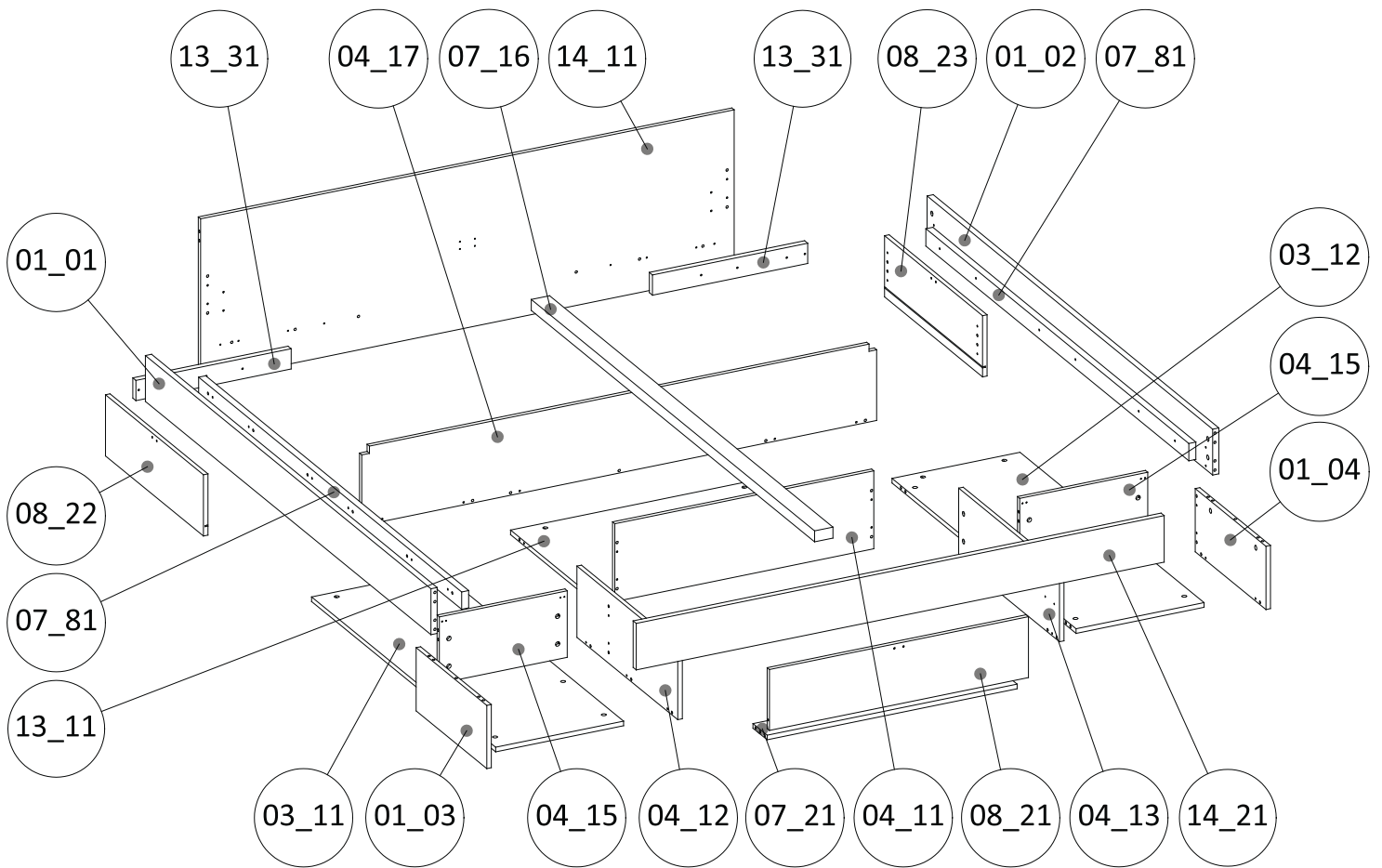
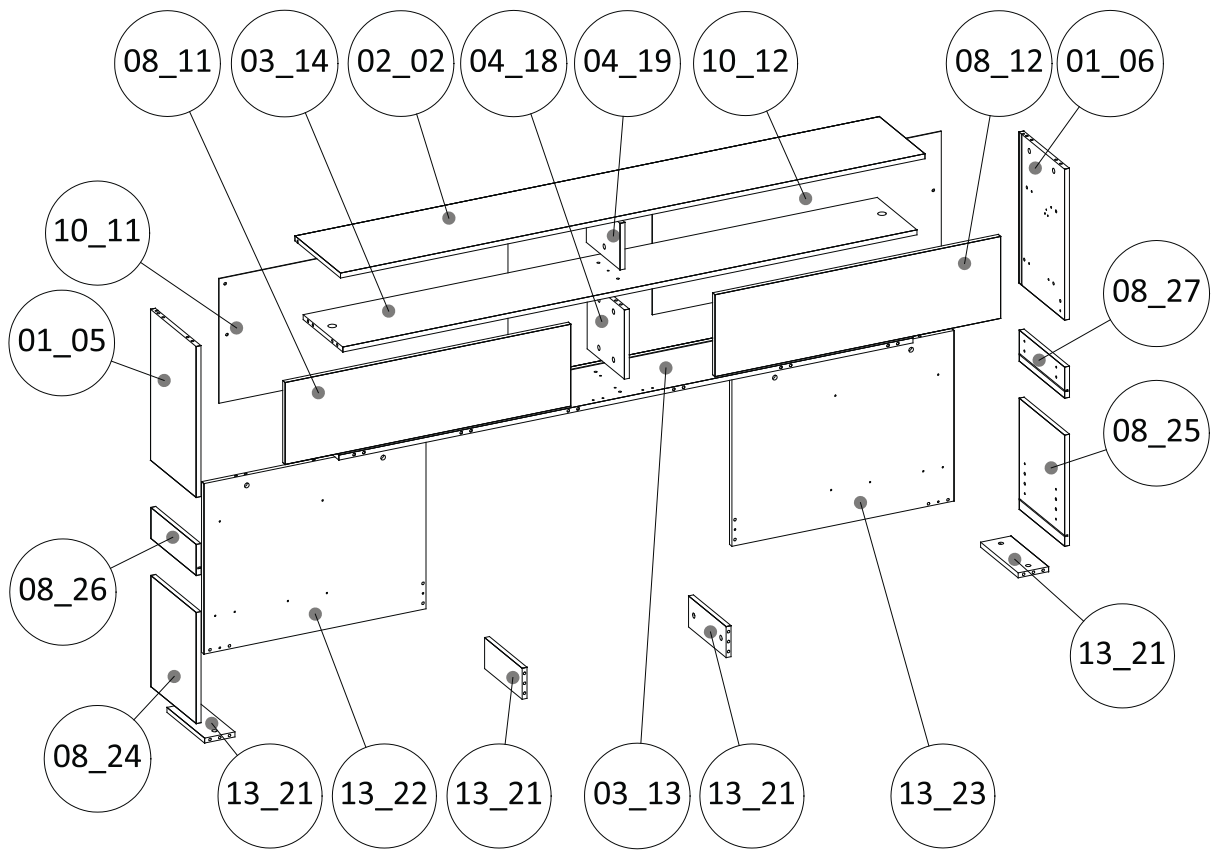

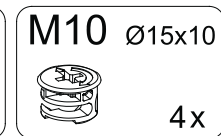
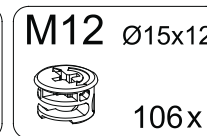
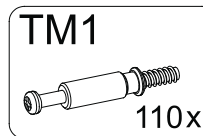
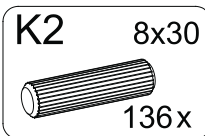
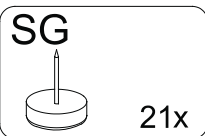
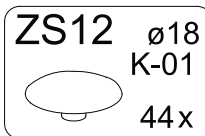
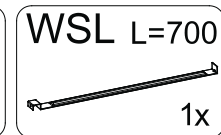
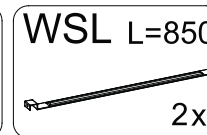
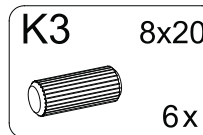
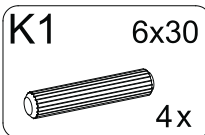
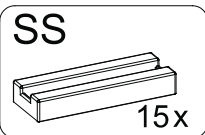
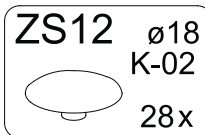
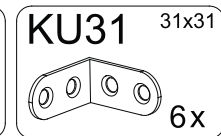
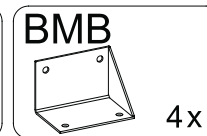
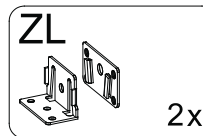
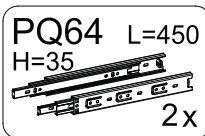
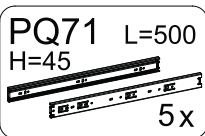
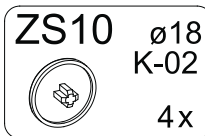
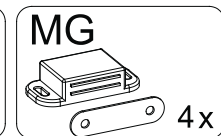
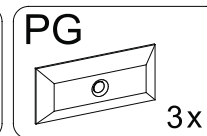
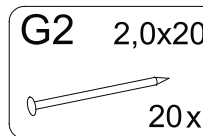
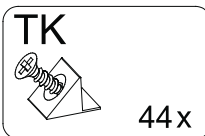
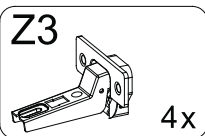
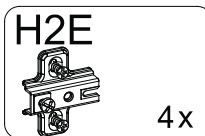
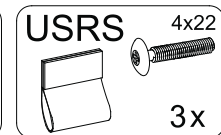
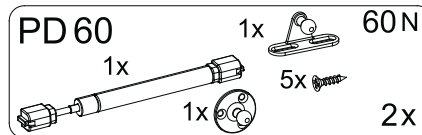
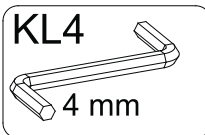
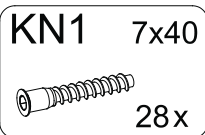
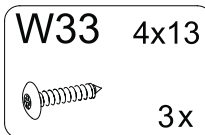
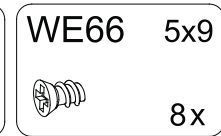
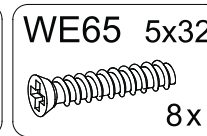
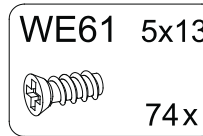
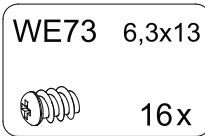
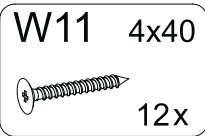
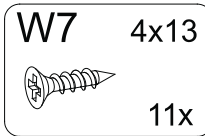
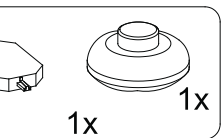
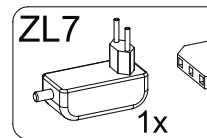
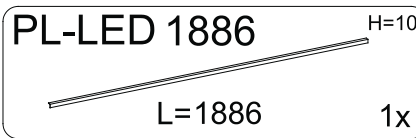
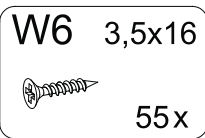
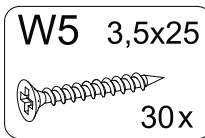
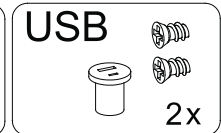
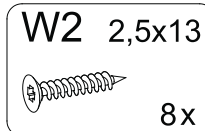
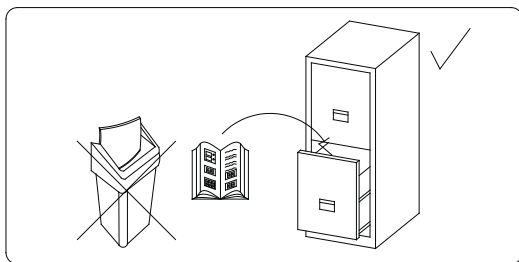
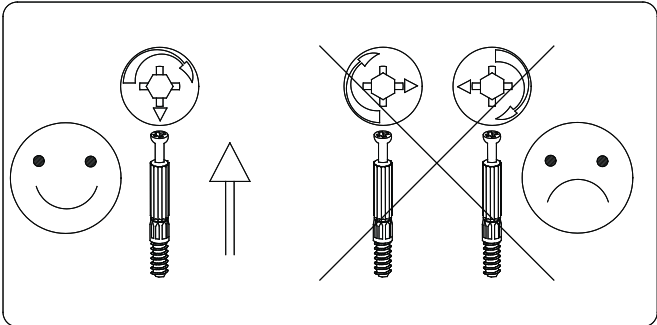
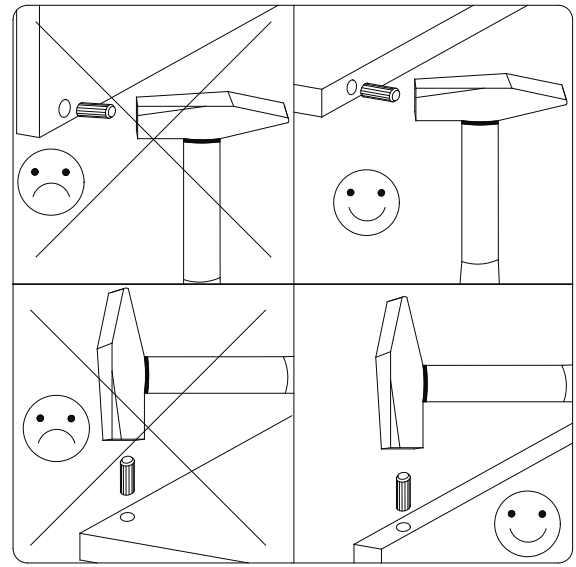
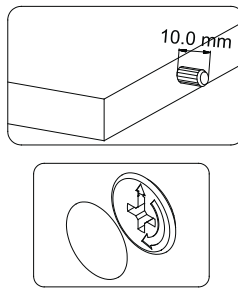
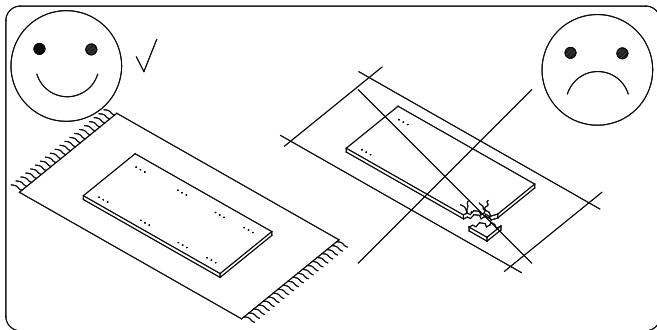

Proszę sprawdzić kompletność okuć przed montażem  
Bitte überprüfen Sie die Vollständigkeit der Fittings vor der Montage  
Please check the completeness of the fittings before assembly  
Пожалуйста, проверьте комплектность фурнитуры перед установкой

Prosím zkontrolujte úplnosť konektorů před instalací  
Prosím skontrolujte úplnosť konektorov pred inštaláciou  
Prije montaže provjerite cjelovitost okova  
Pre postavljanja proverite kompletnost okova  
Kérjük, ellenőrizze a szerelvények teljességét a szerelés előtt

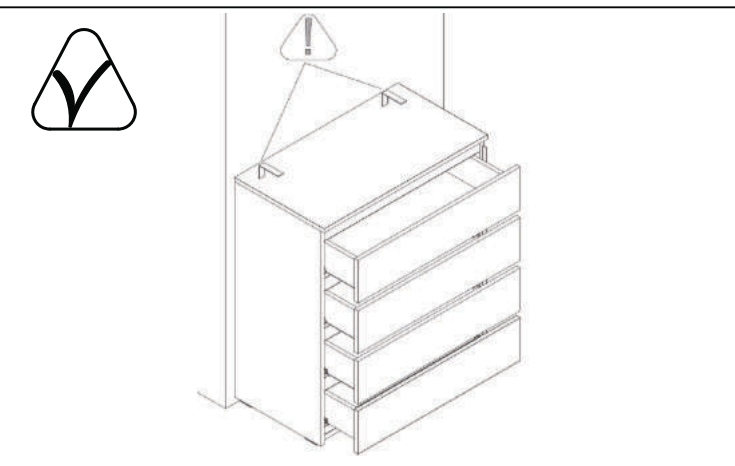
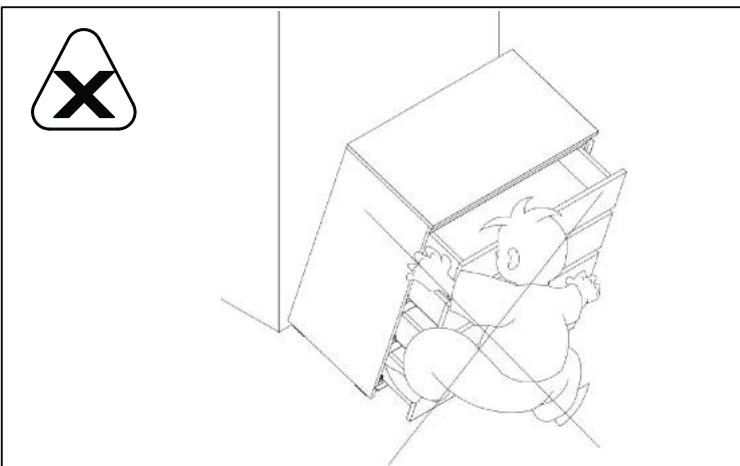
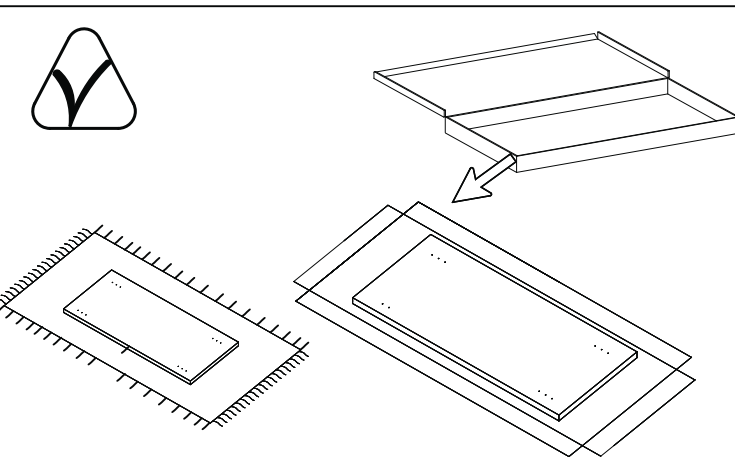
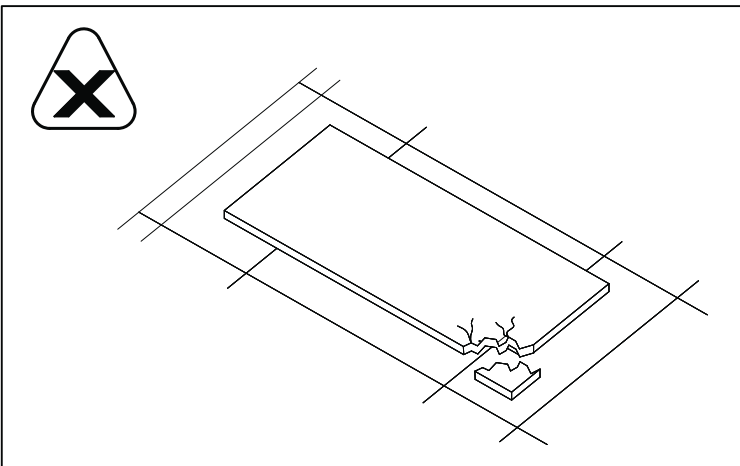
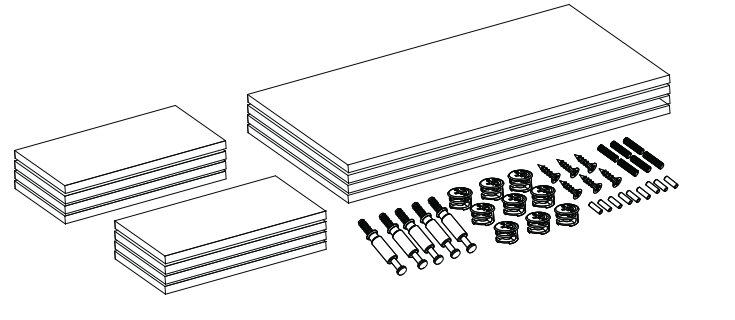
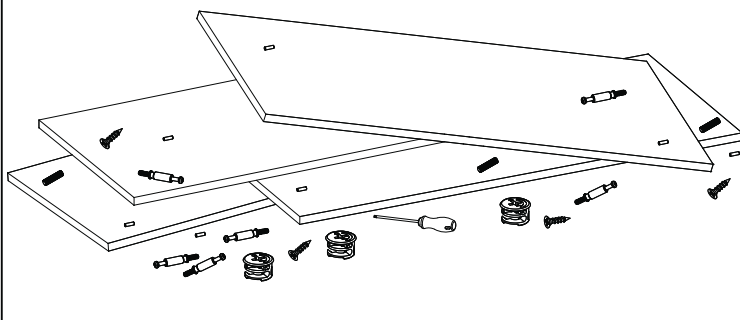
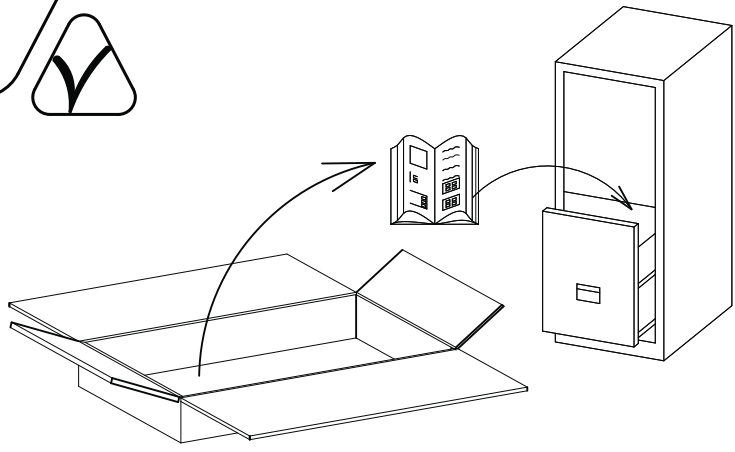
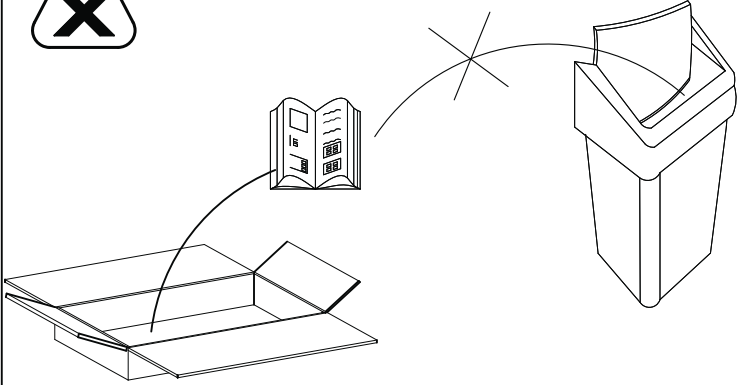

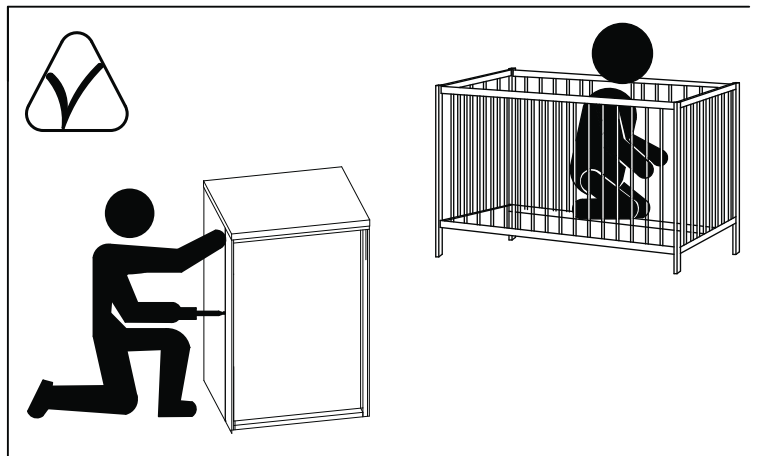
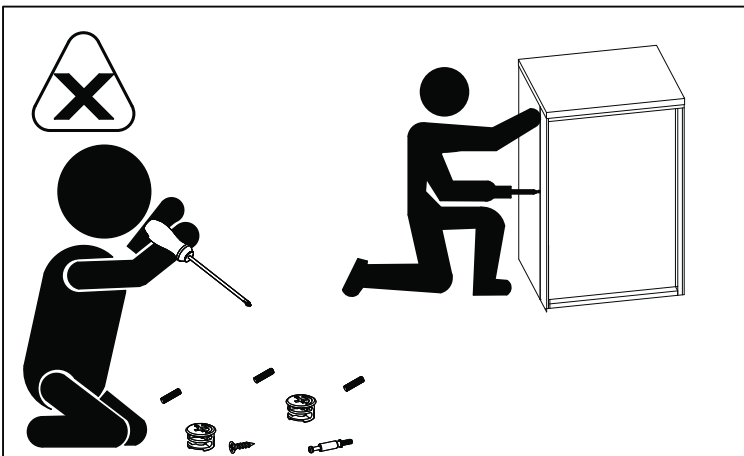
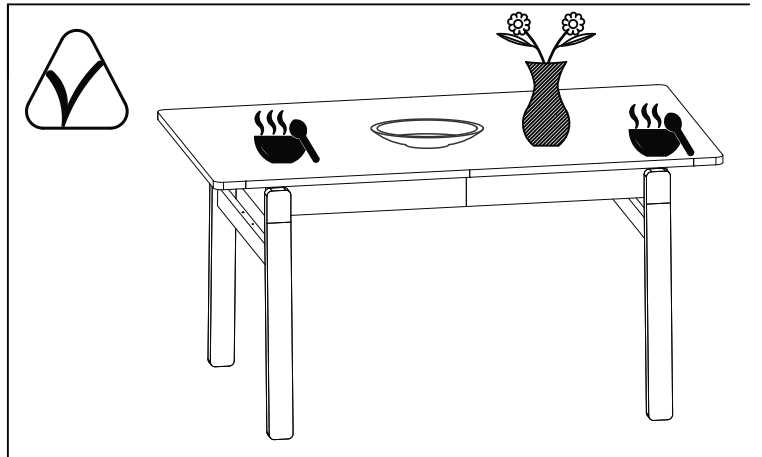
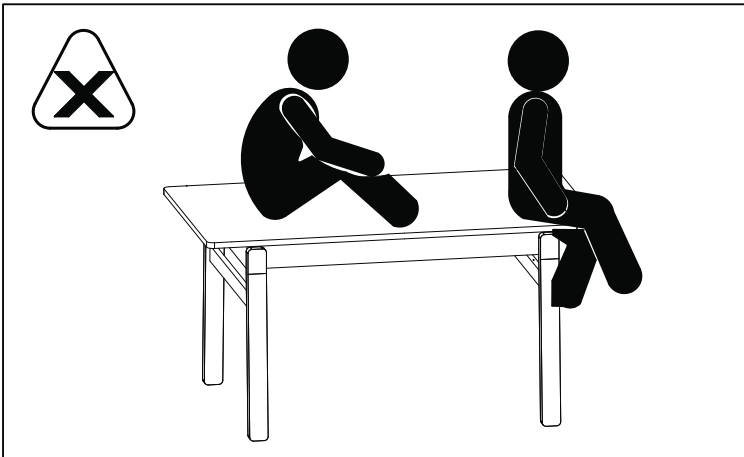
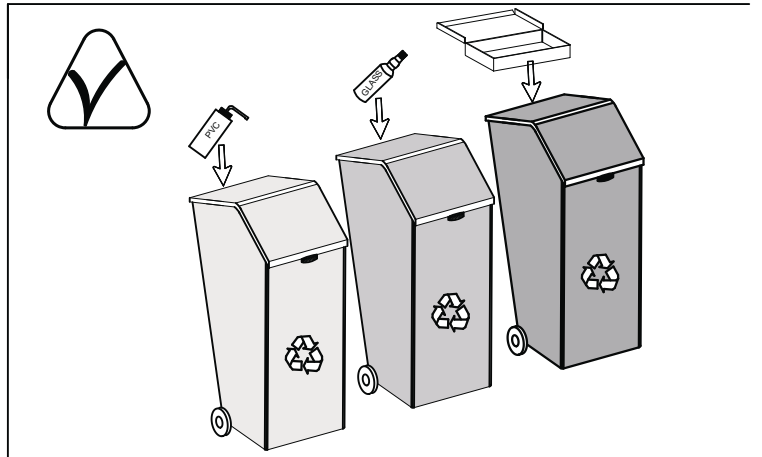
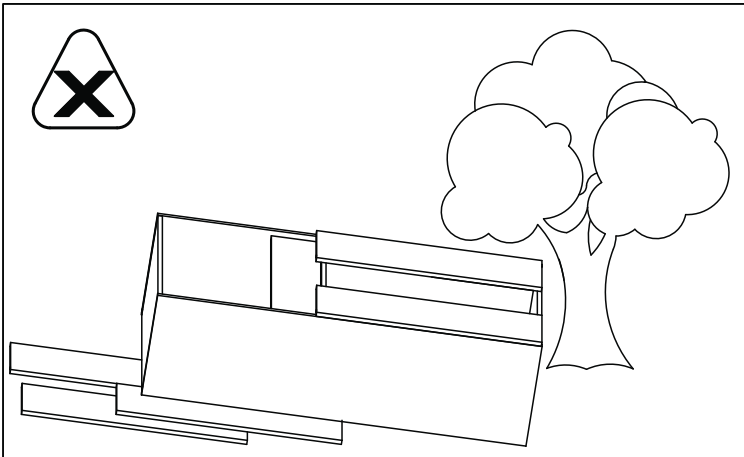
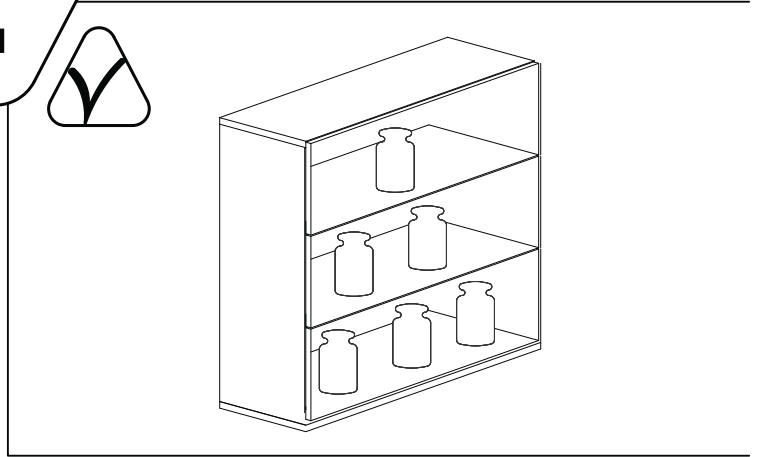
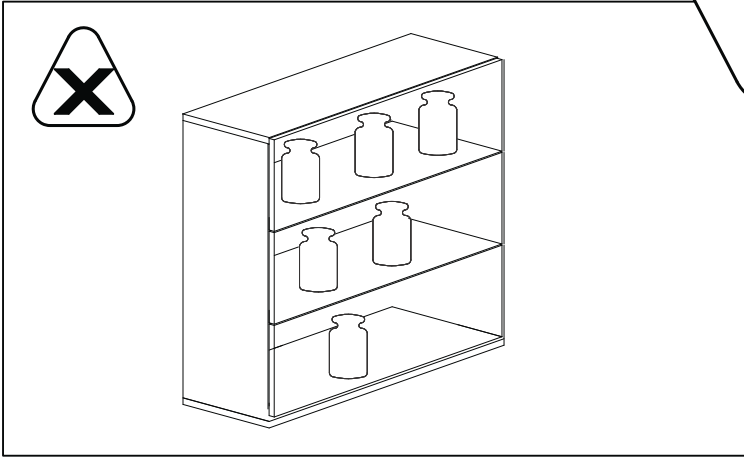

1

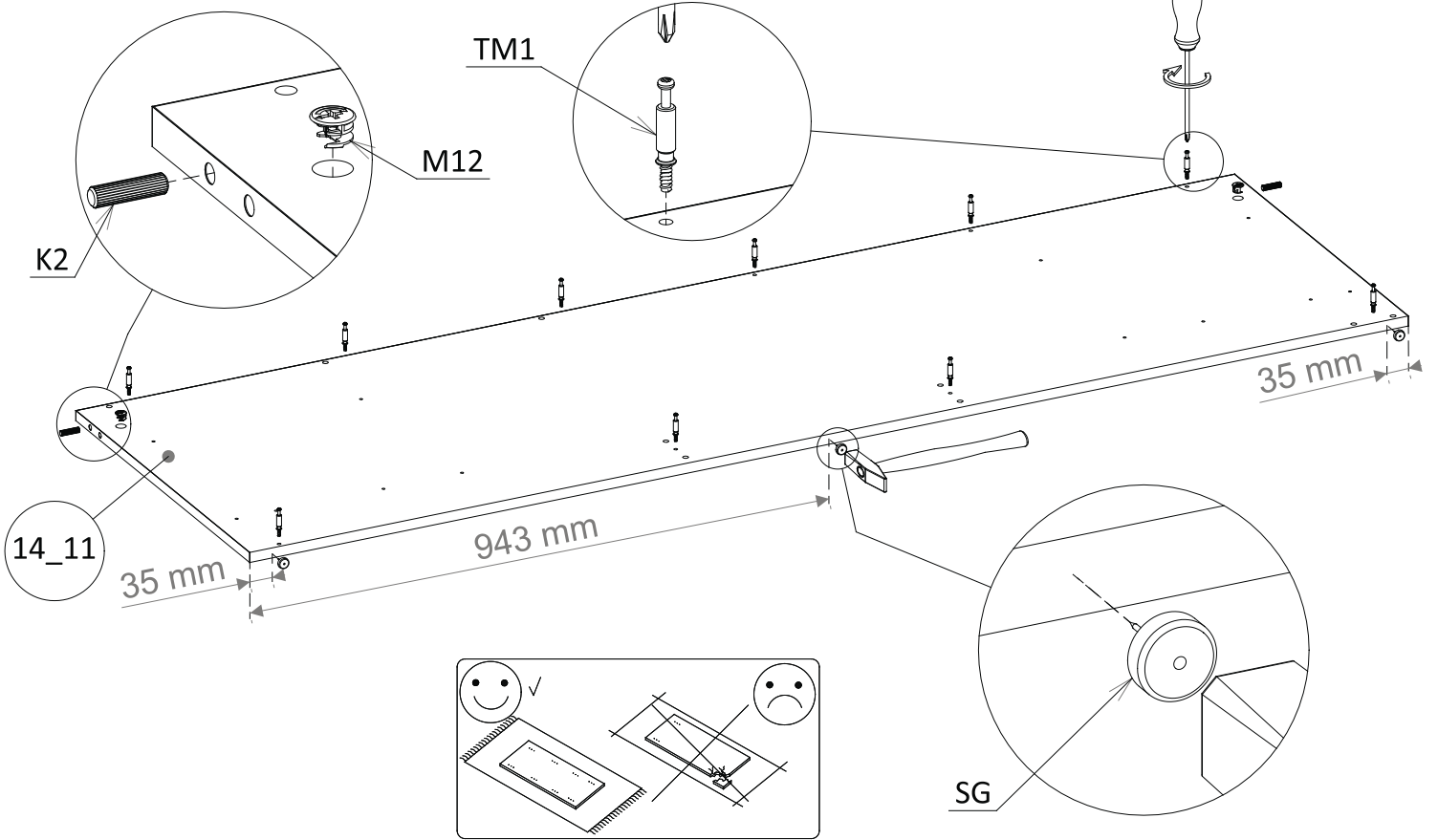
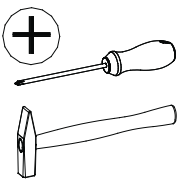
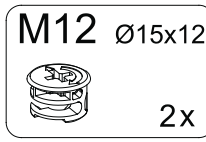
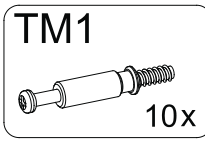
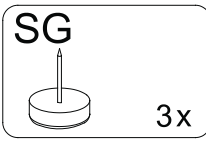
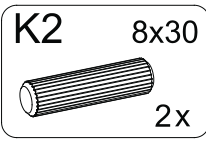

2

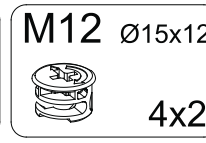
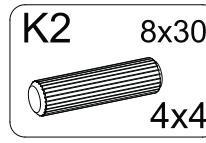

4x

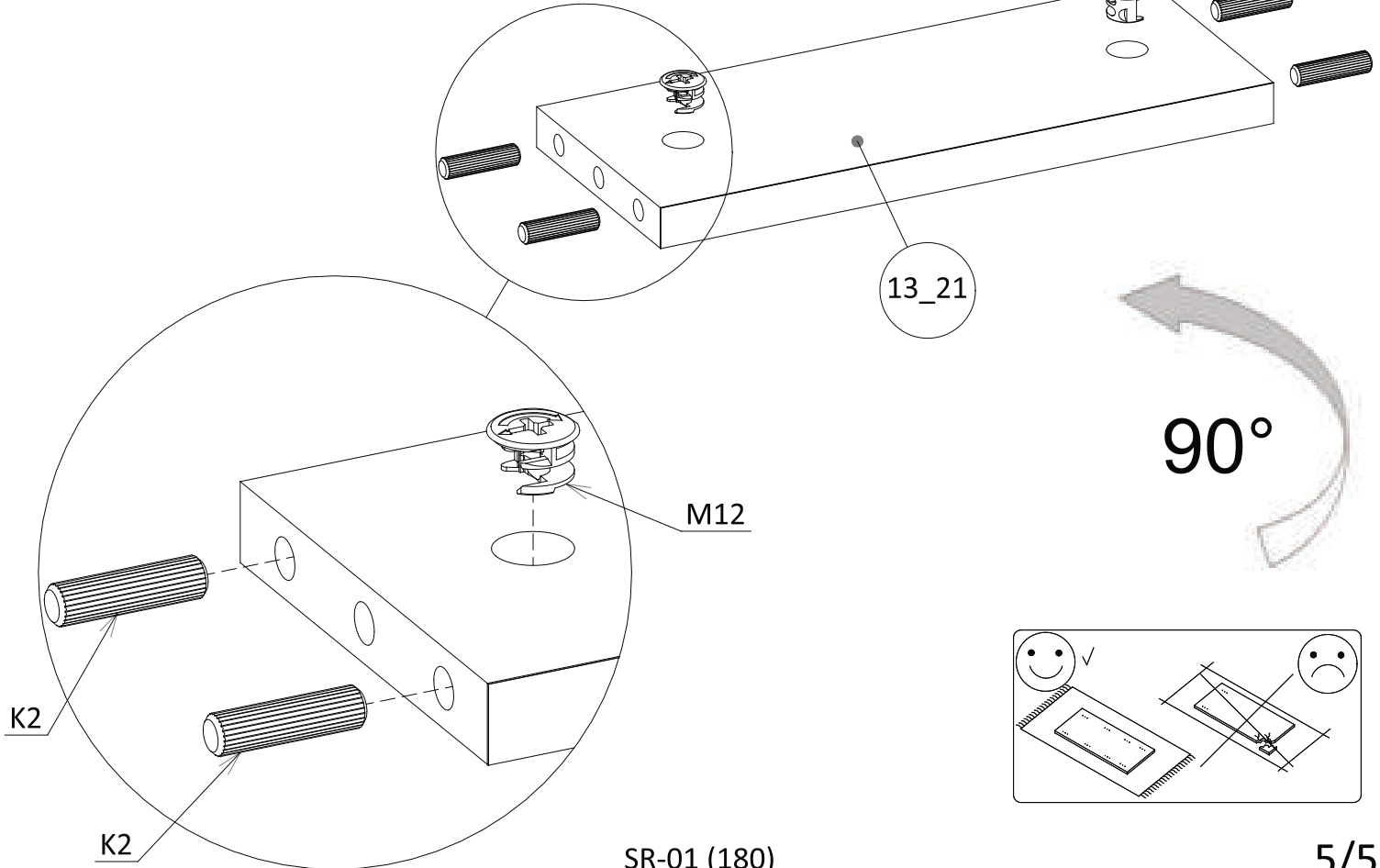

# 3

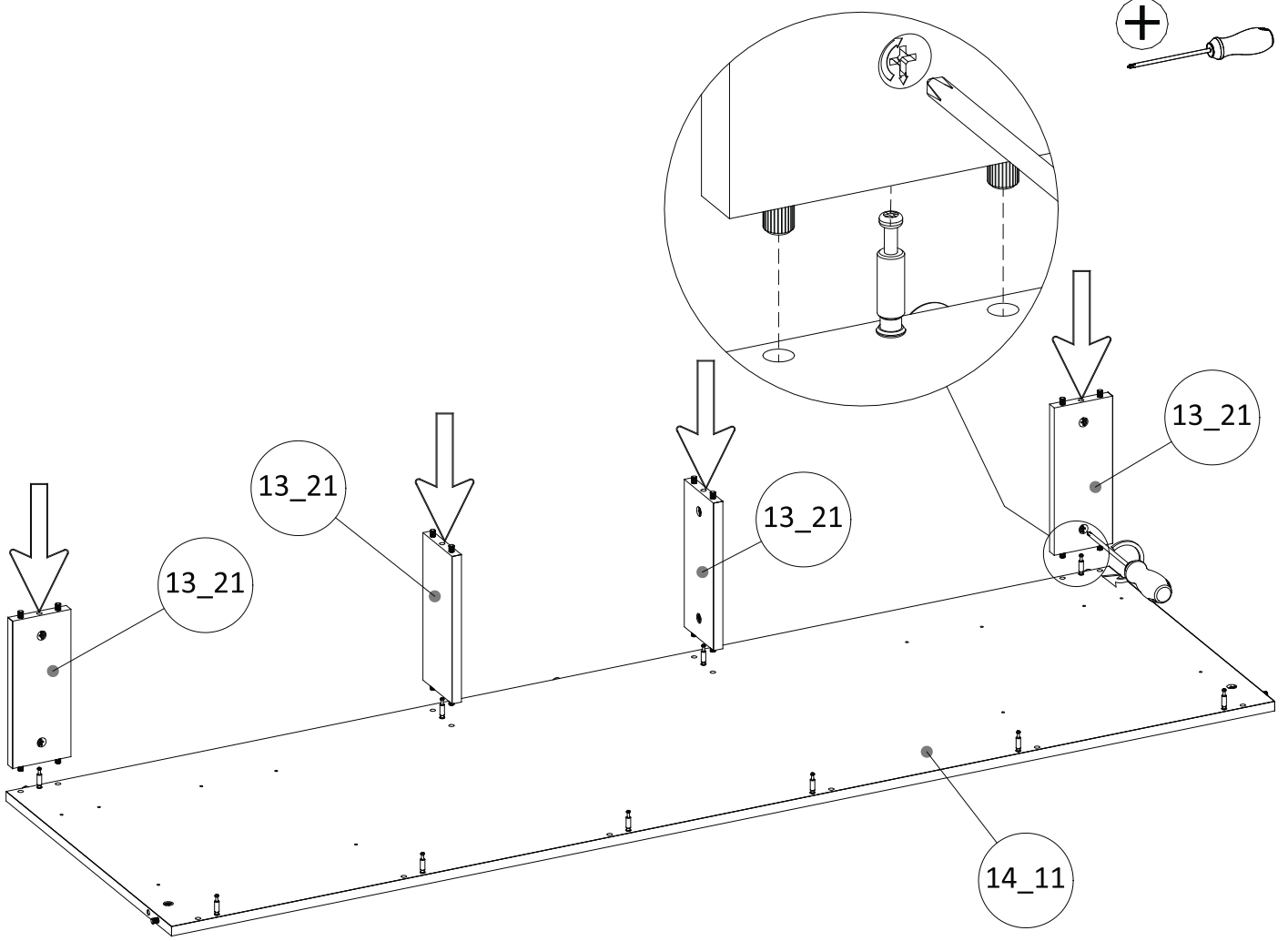

# 4

- K2** 8x30 10x
- TM1** 4x
- M12** Ø15x12 10x

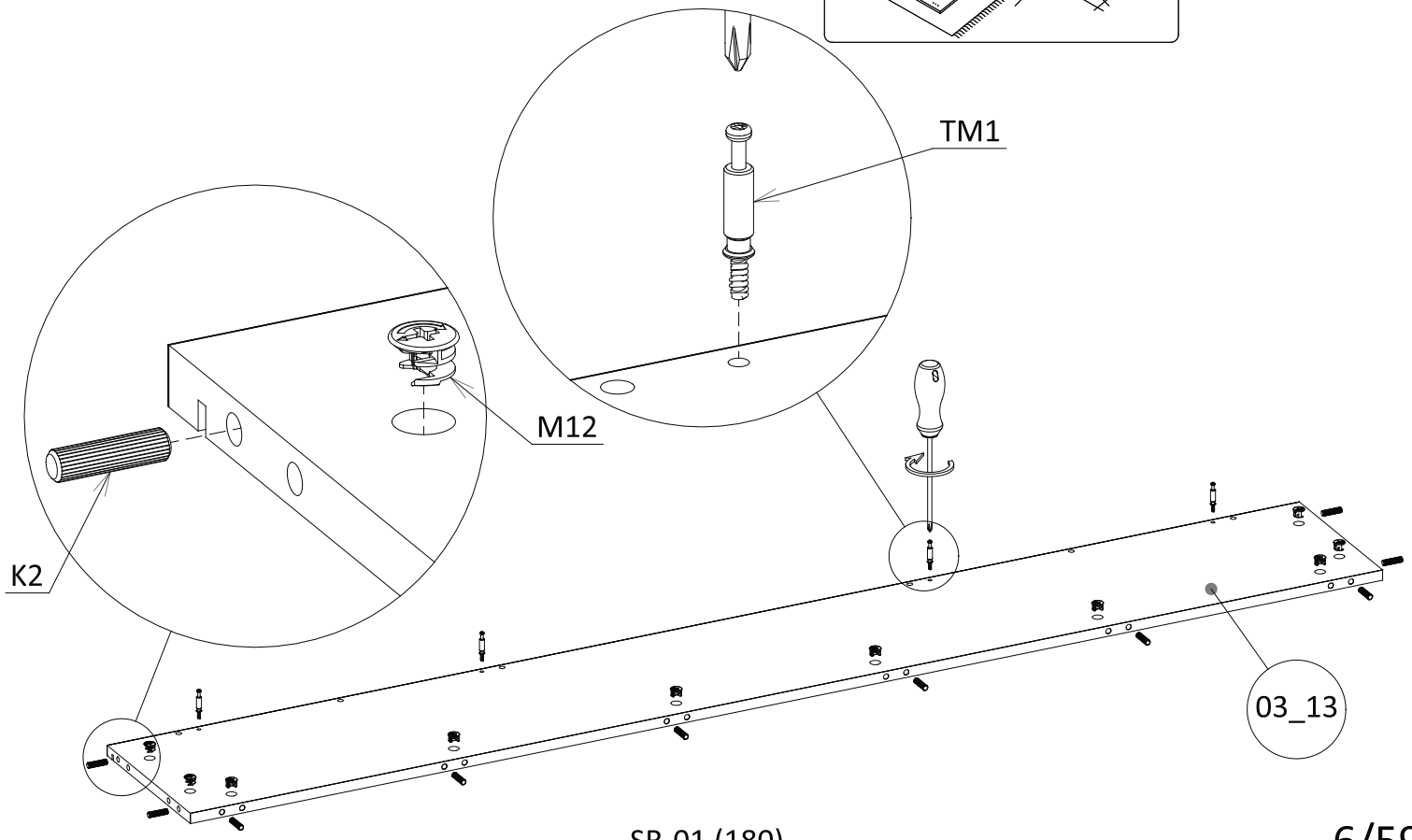
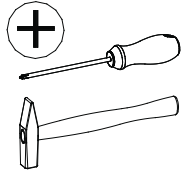
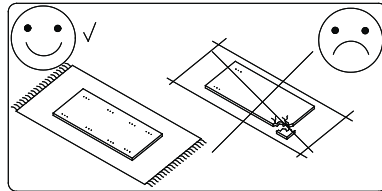

5

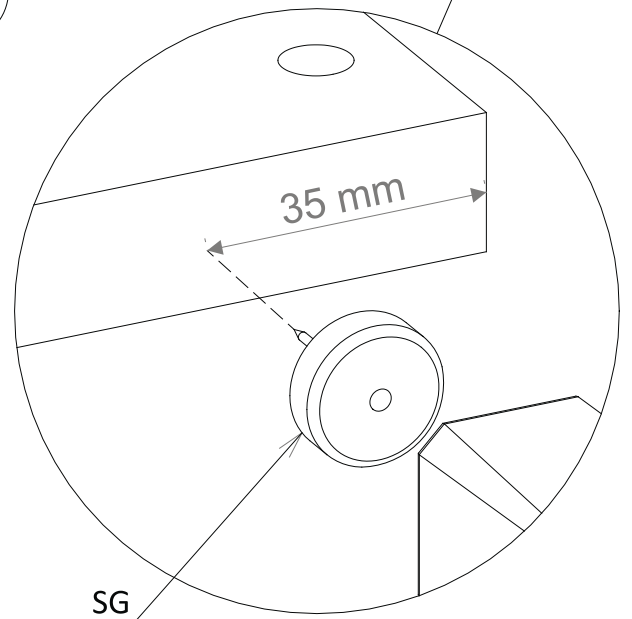
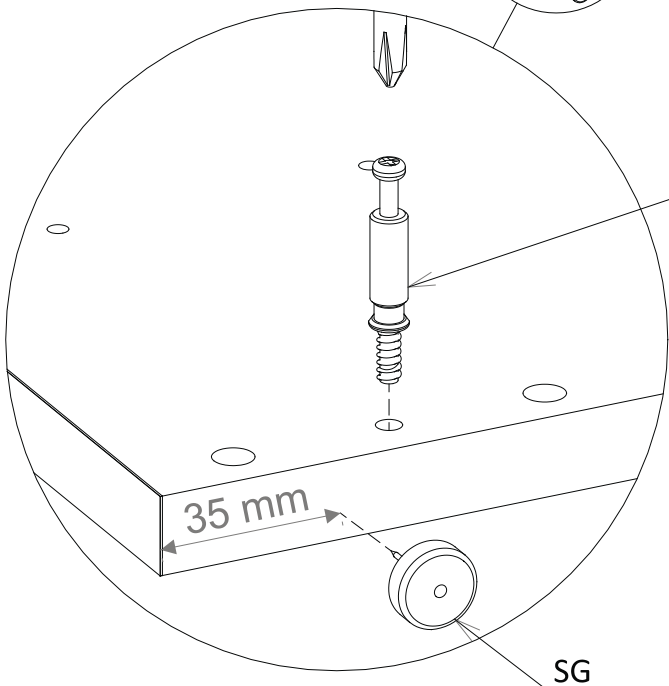
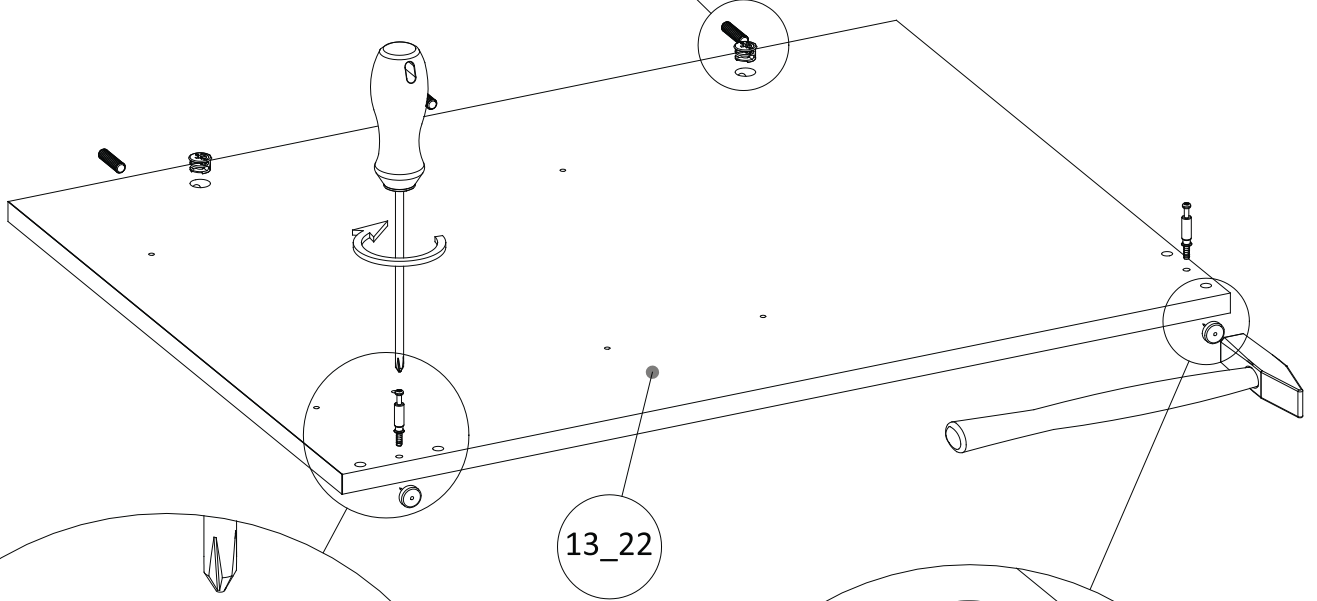
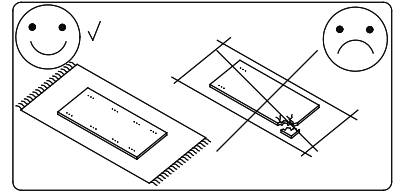
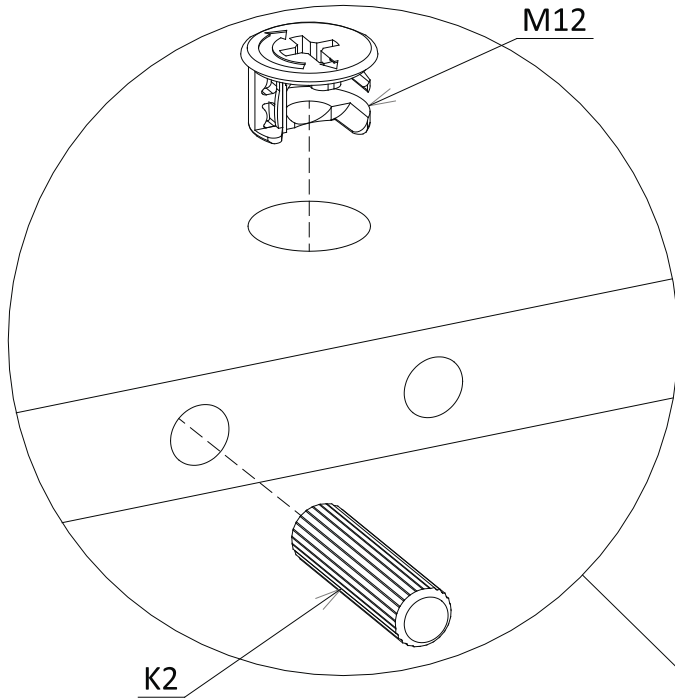
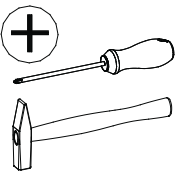
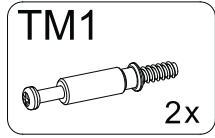
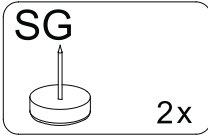
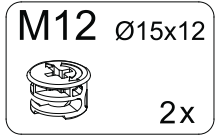
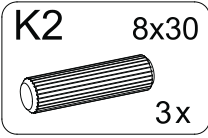

6

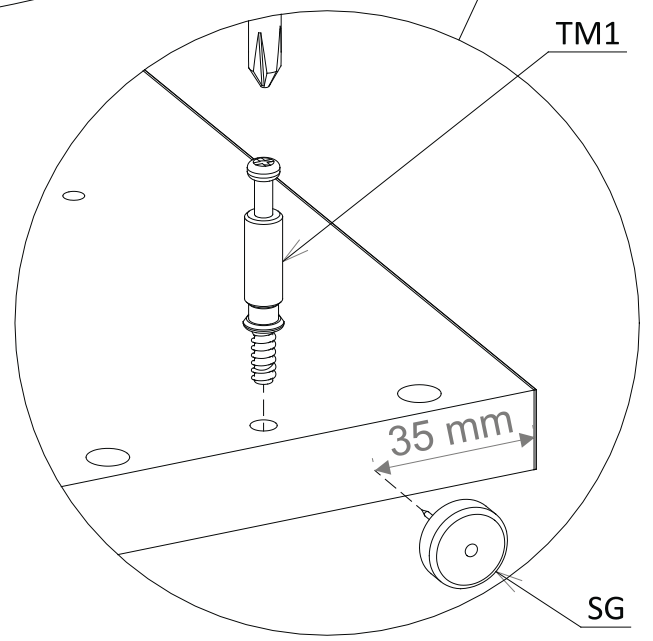
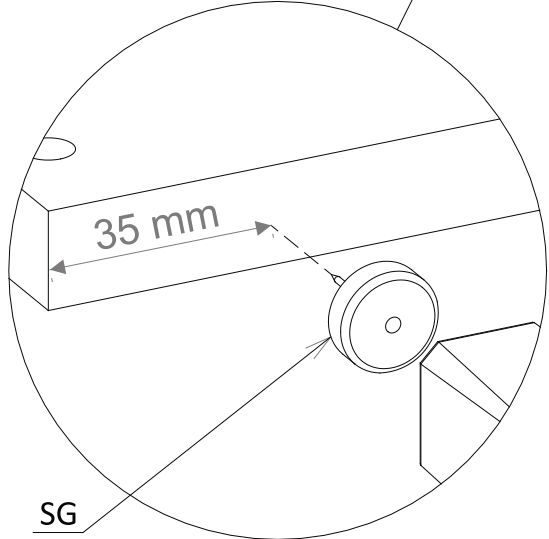
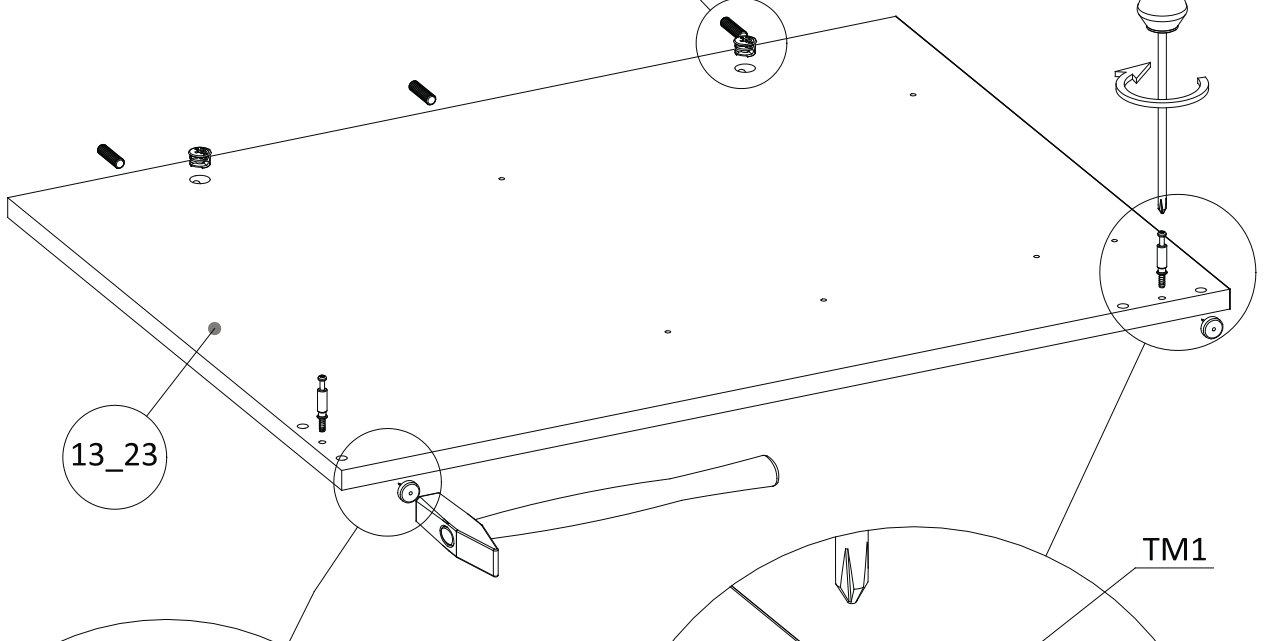
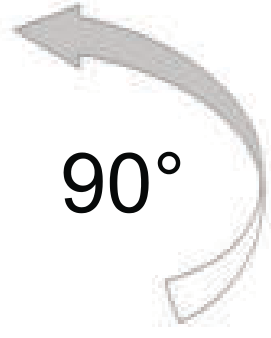
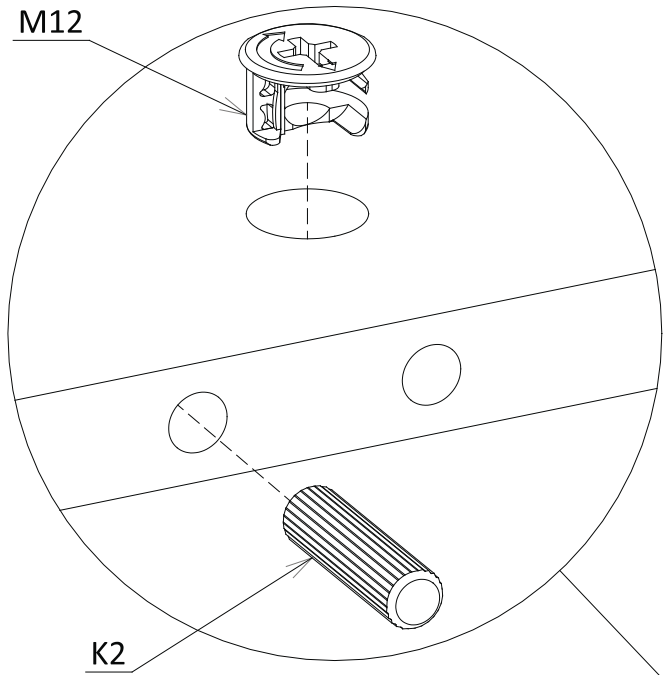
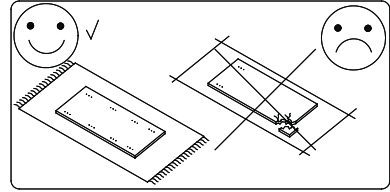
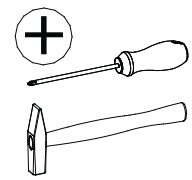
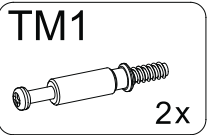
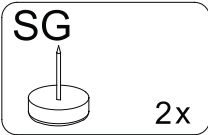
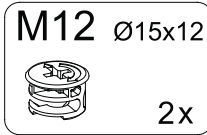
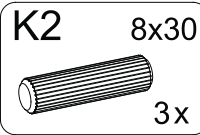

7

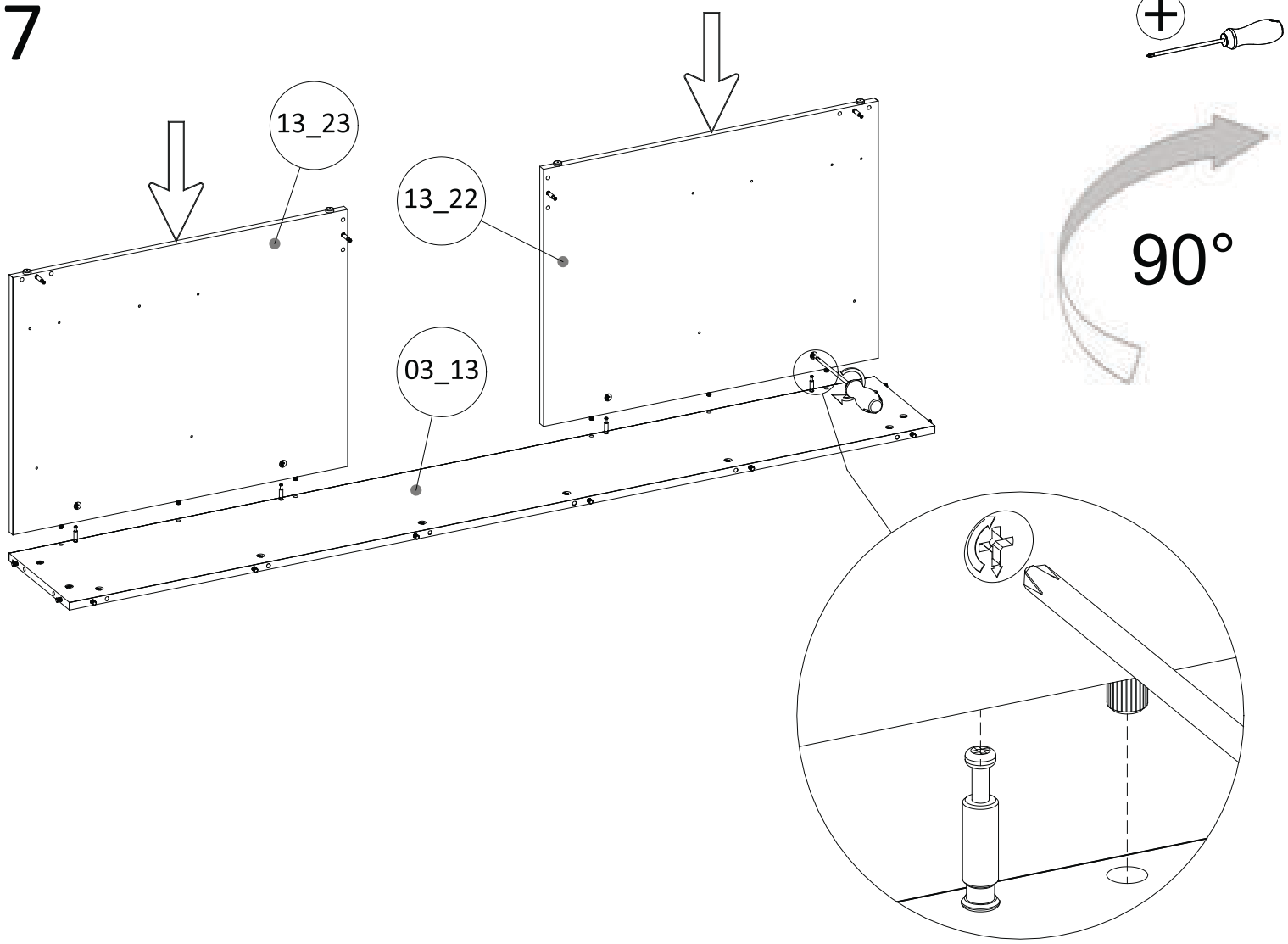

8

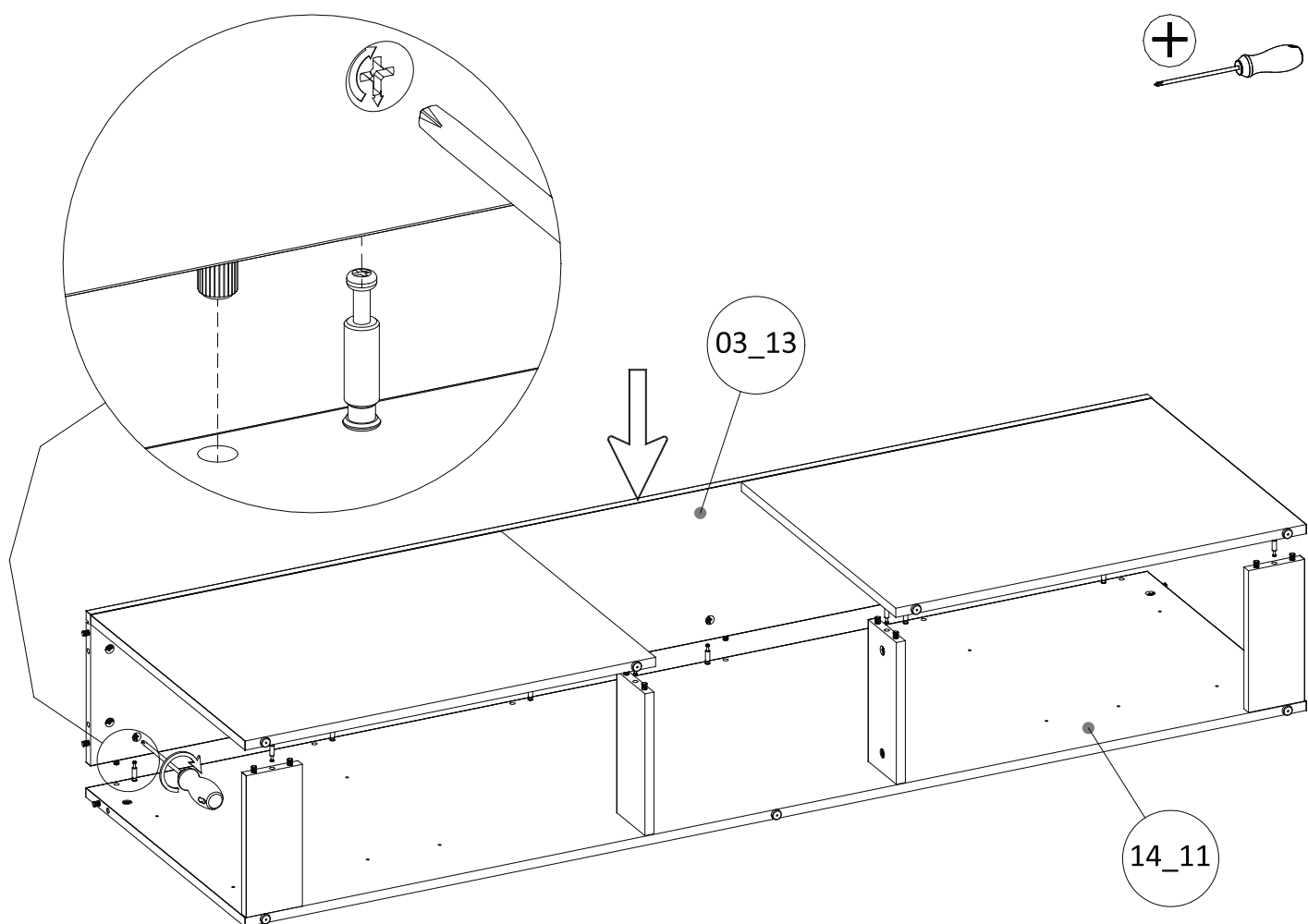

9

K2 8x30  
4x

M12 Ø15x12  
4x

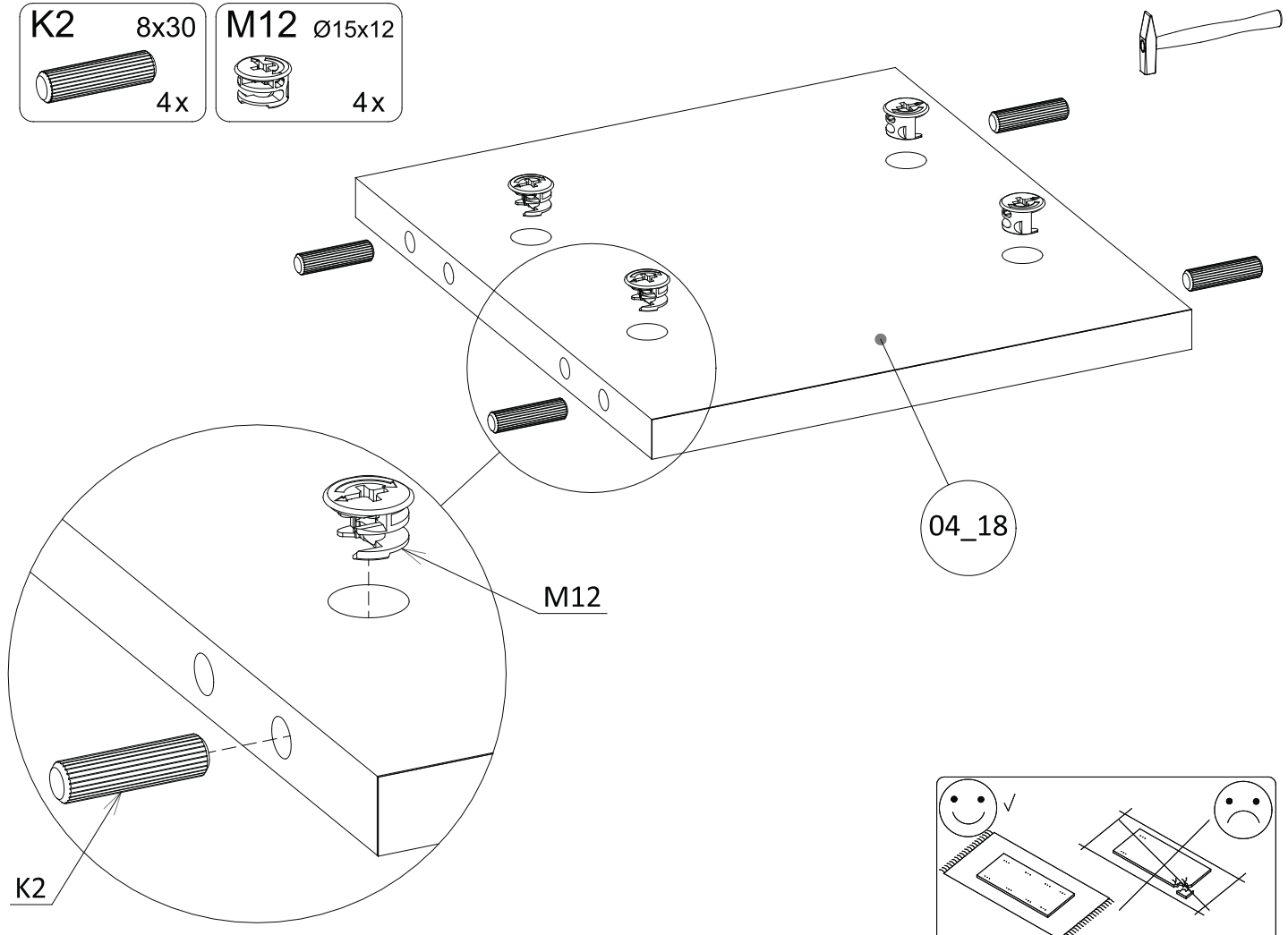

10

K2 8x30  
4x

TM1  
2x

M12 Ø15x12  
4x

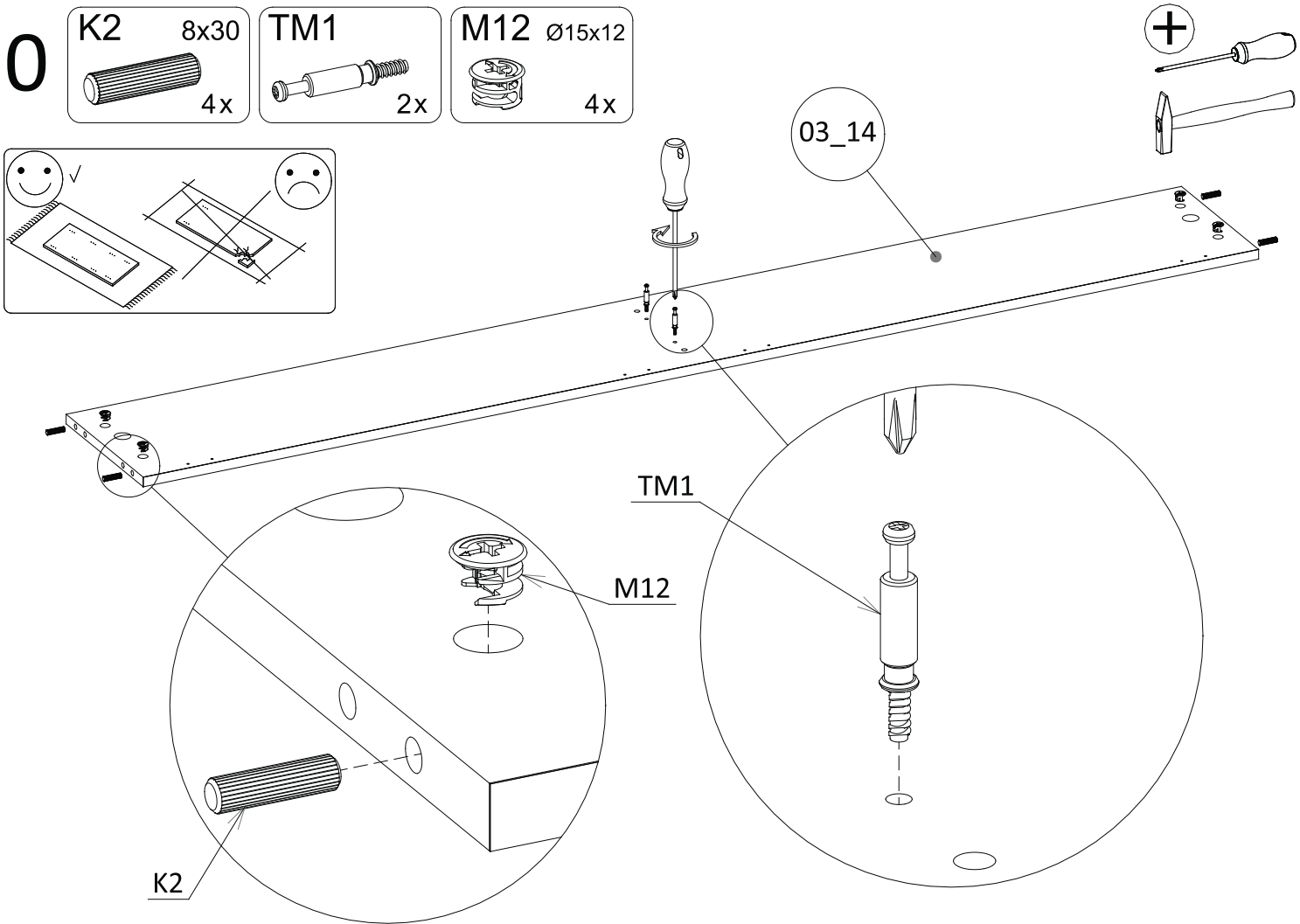

# 11

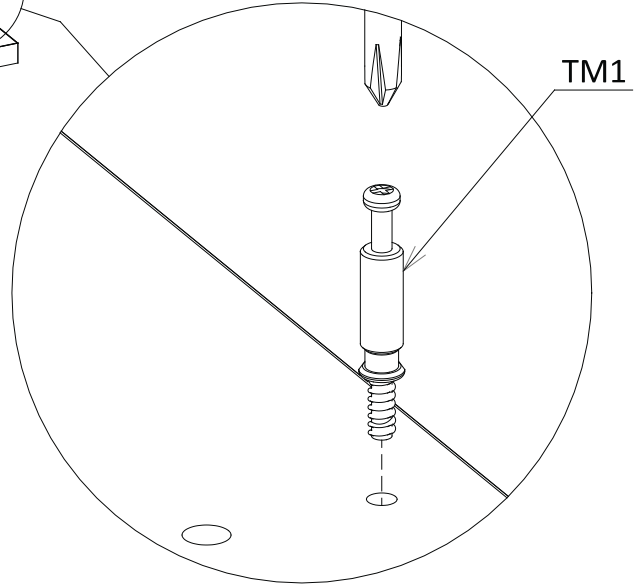
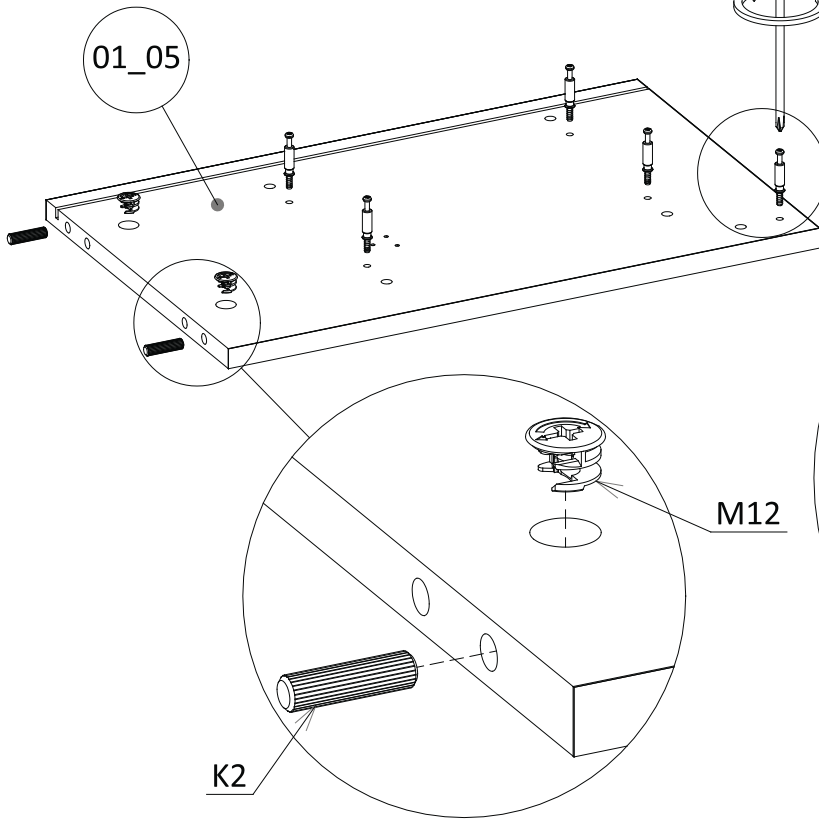
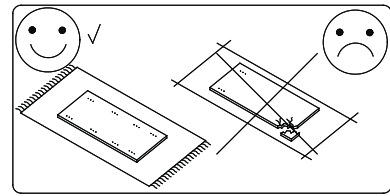
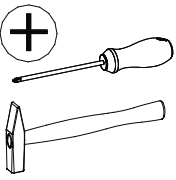
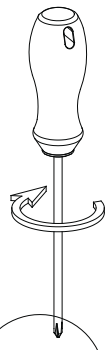
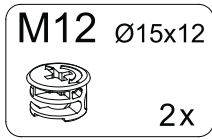
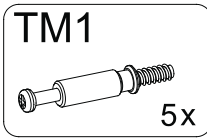
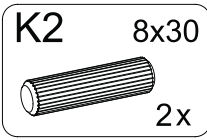

# 12

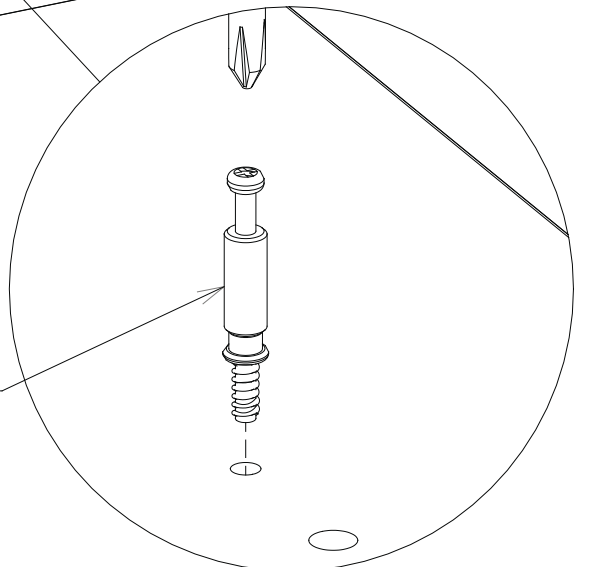
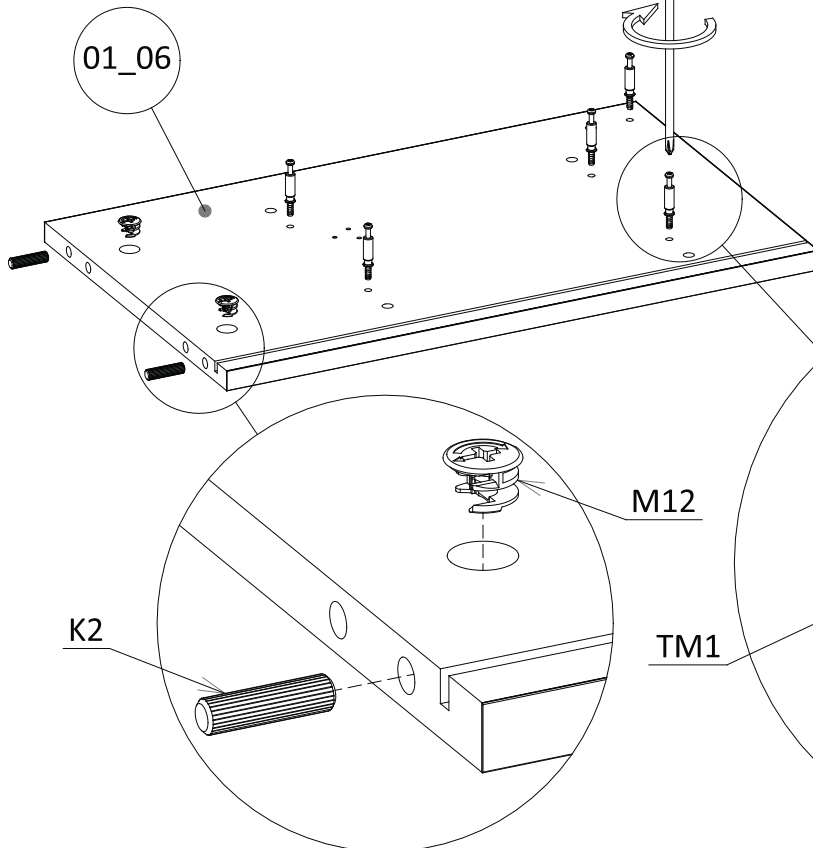
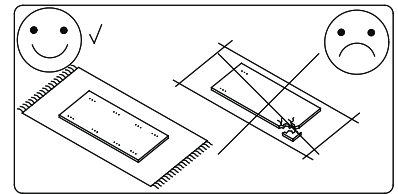
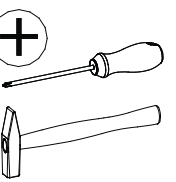
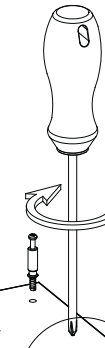
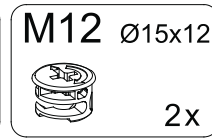
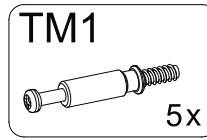
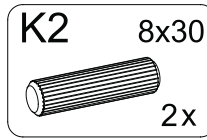

# 13

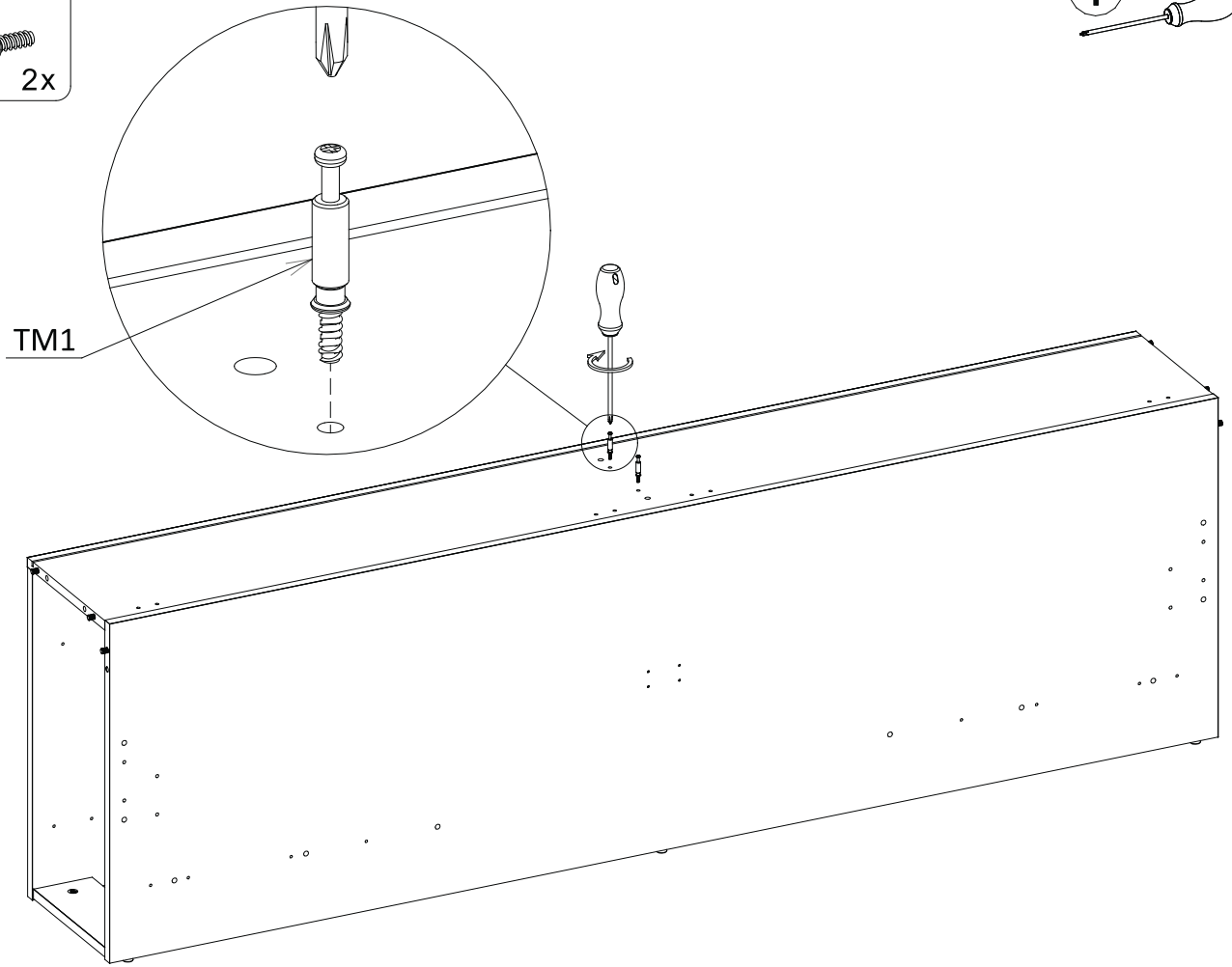
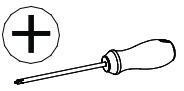
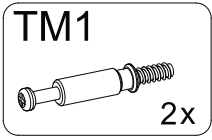

# 14

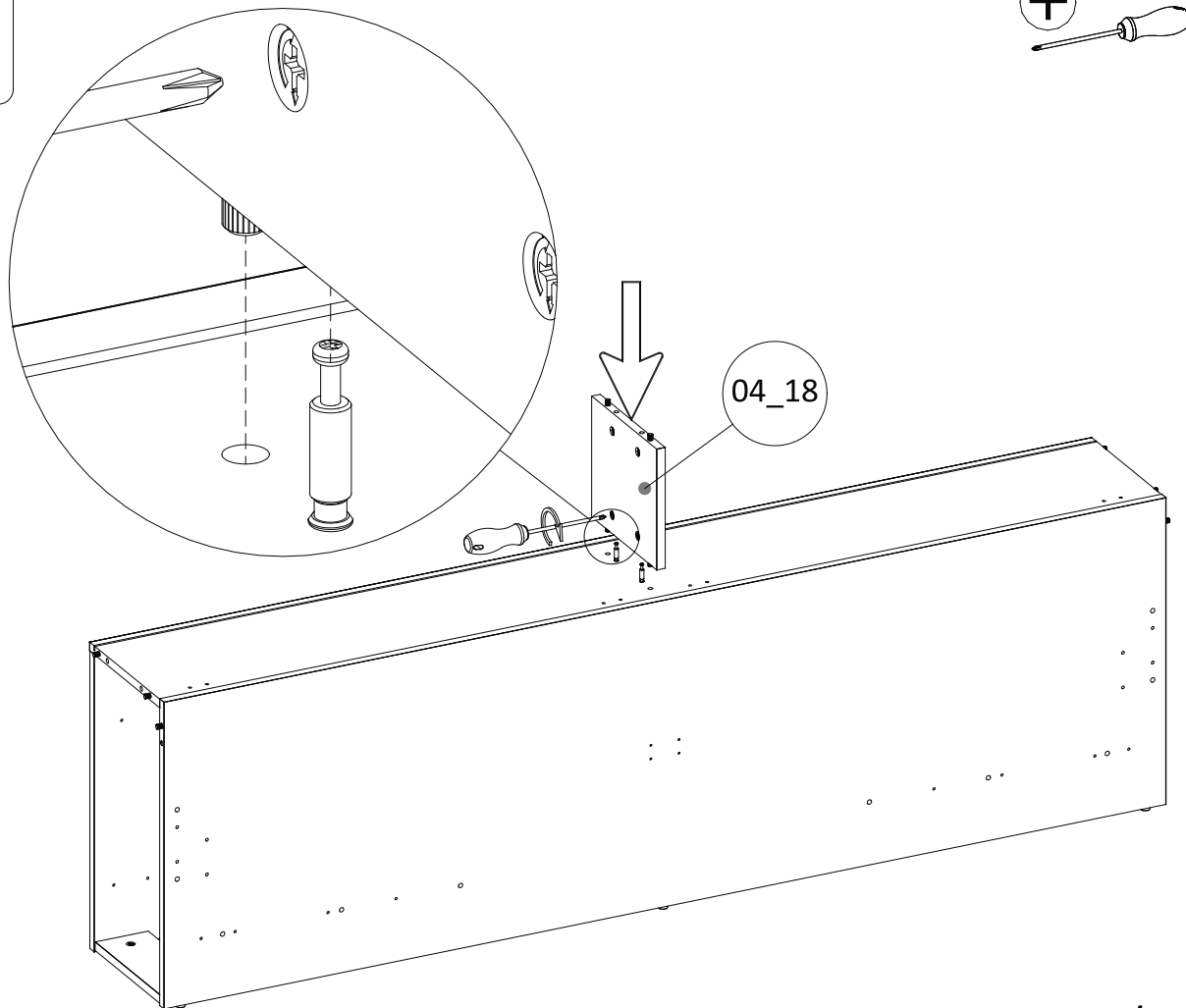
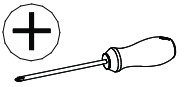
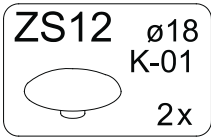

# 15

ZS12  $\varnothing 18$   
K-01  
2x

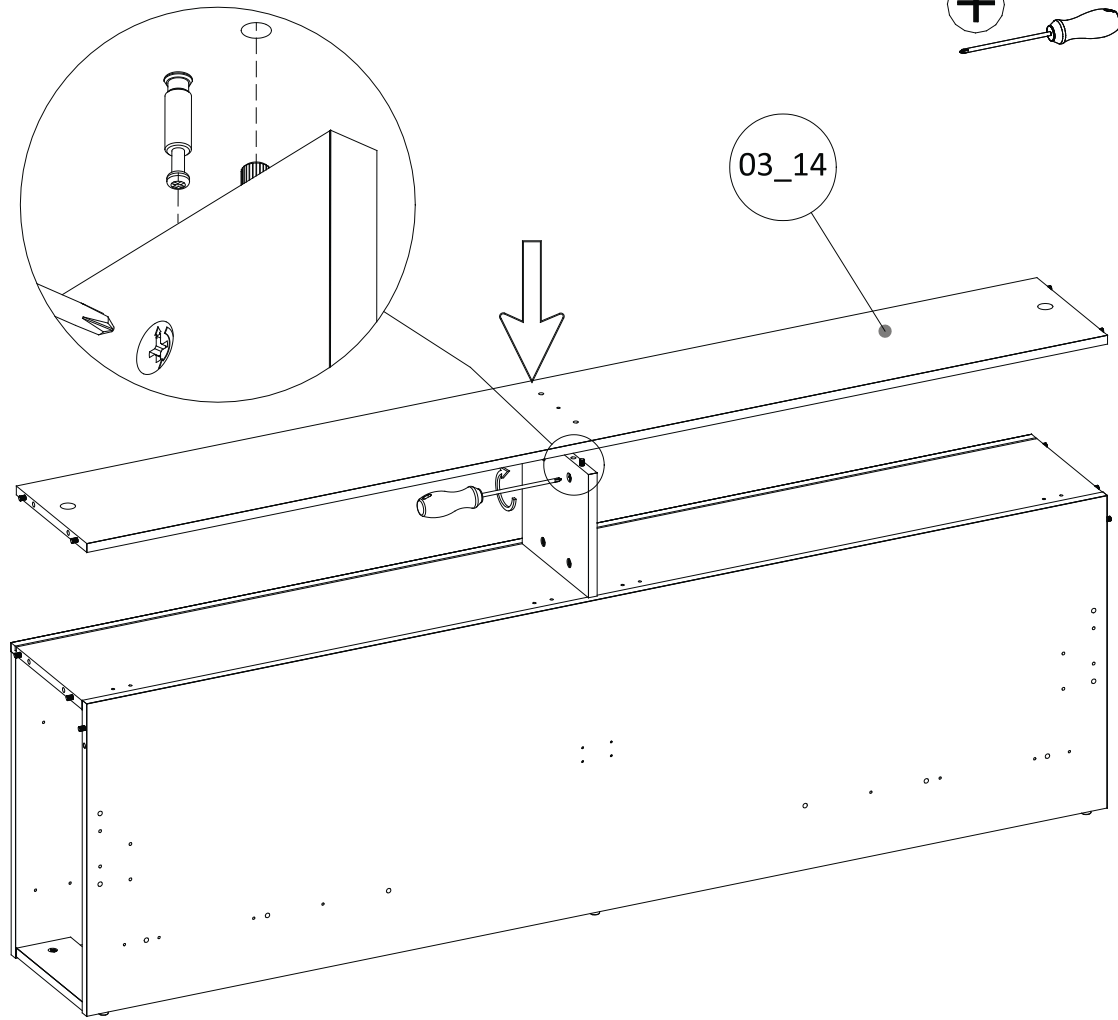
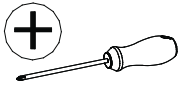

# 16

ZS12  $\varnothing 18$   
K-01  
4x

TM1  
1x

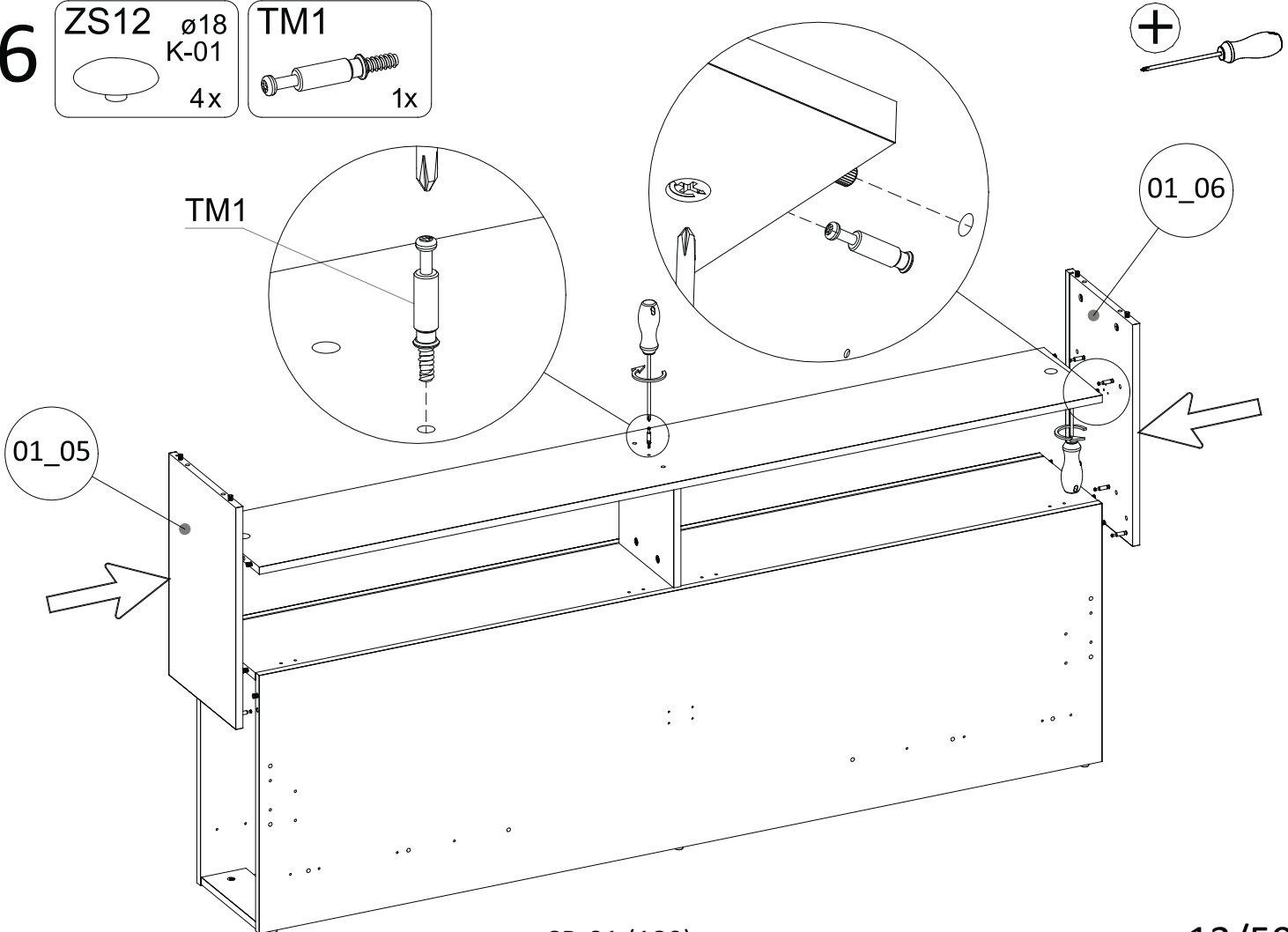
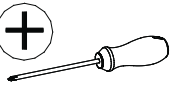

# 17

- K2** 8x30 4x
- M12** Ø15x12 2x

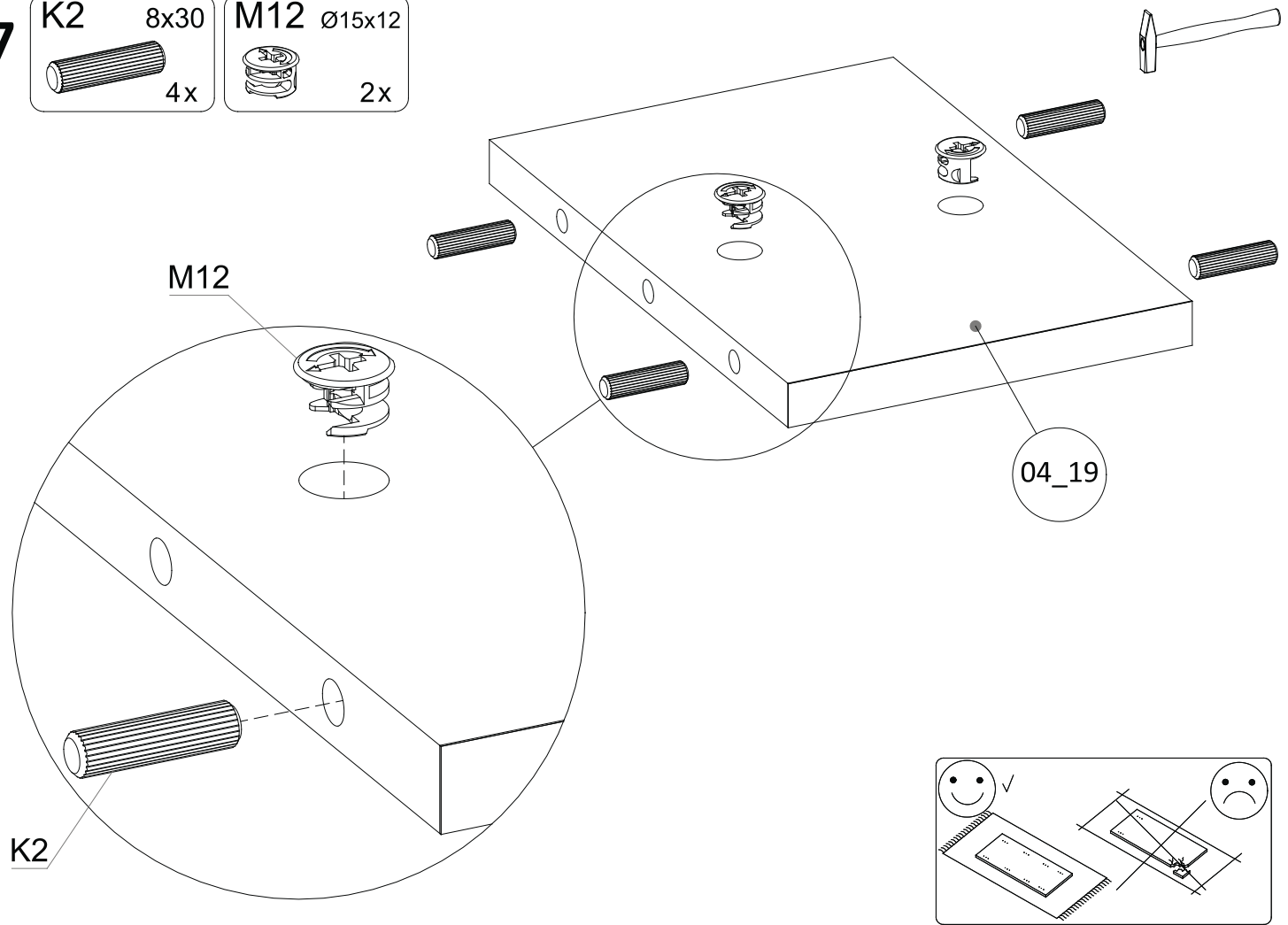

# 18

- TM1** 5x

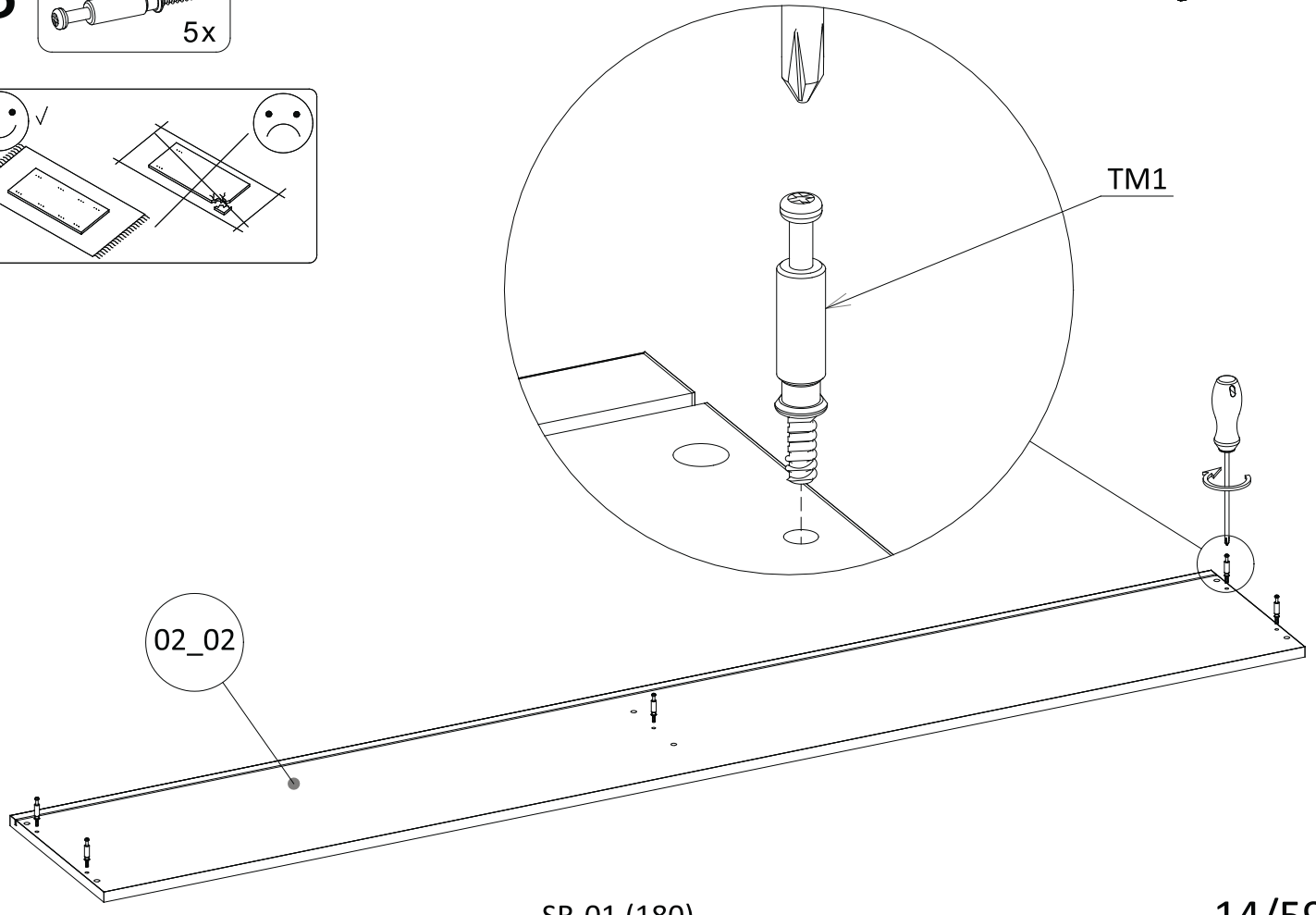
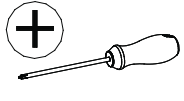
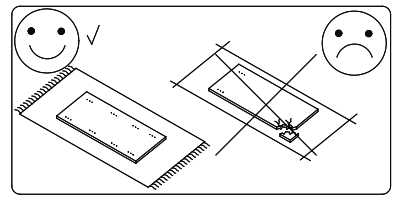

# 19

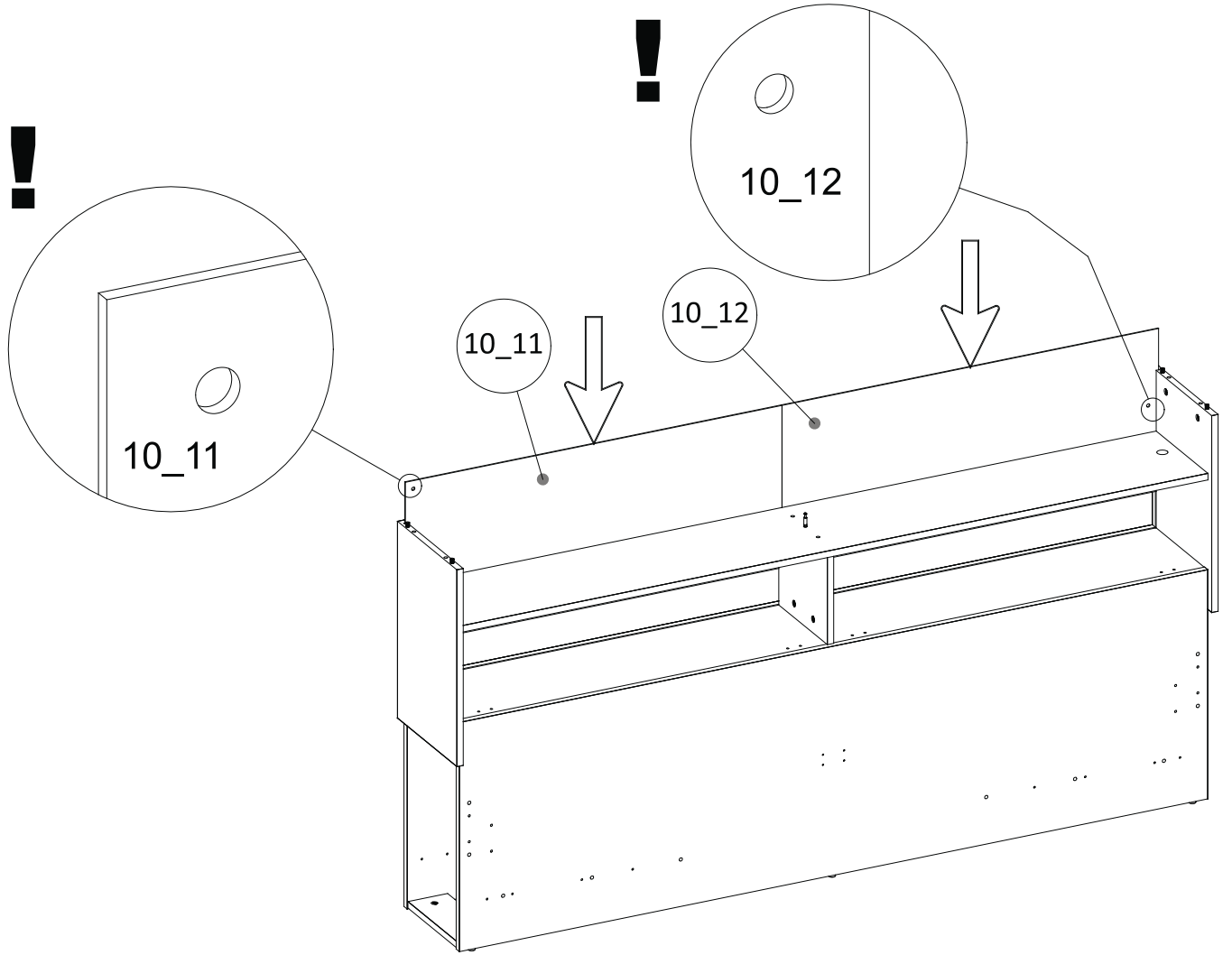

# 20

ZS12  $\varnothing 18$   
K-01  
1x

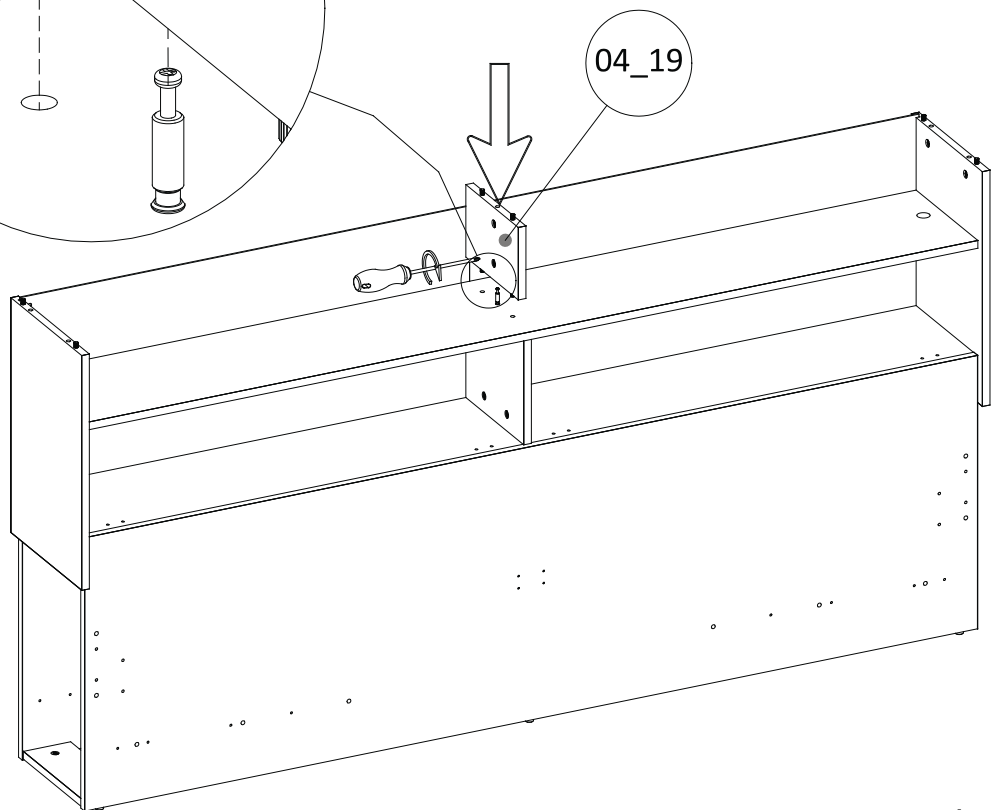
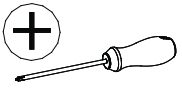
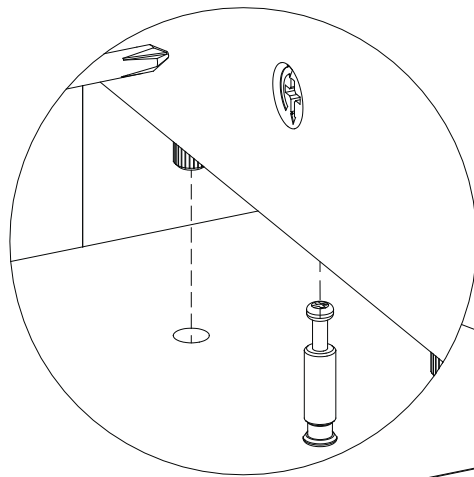

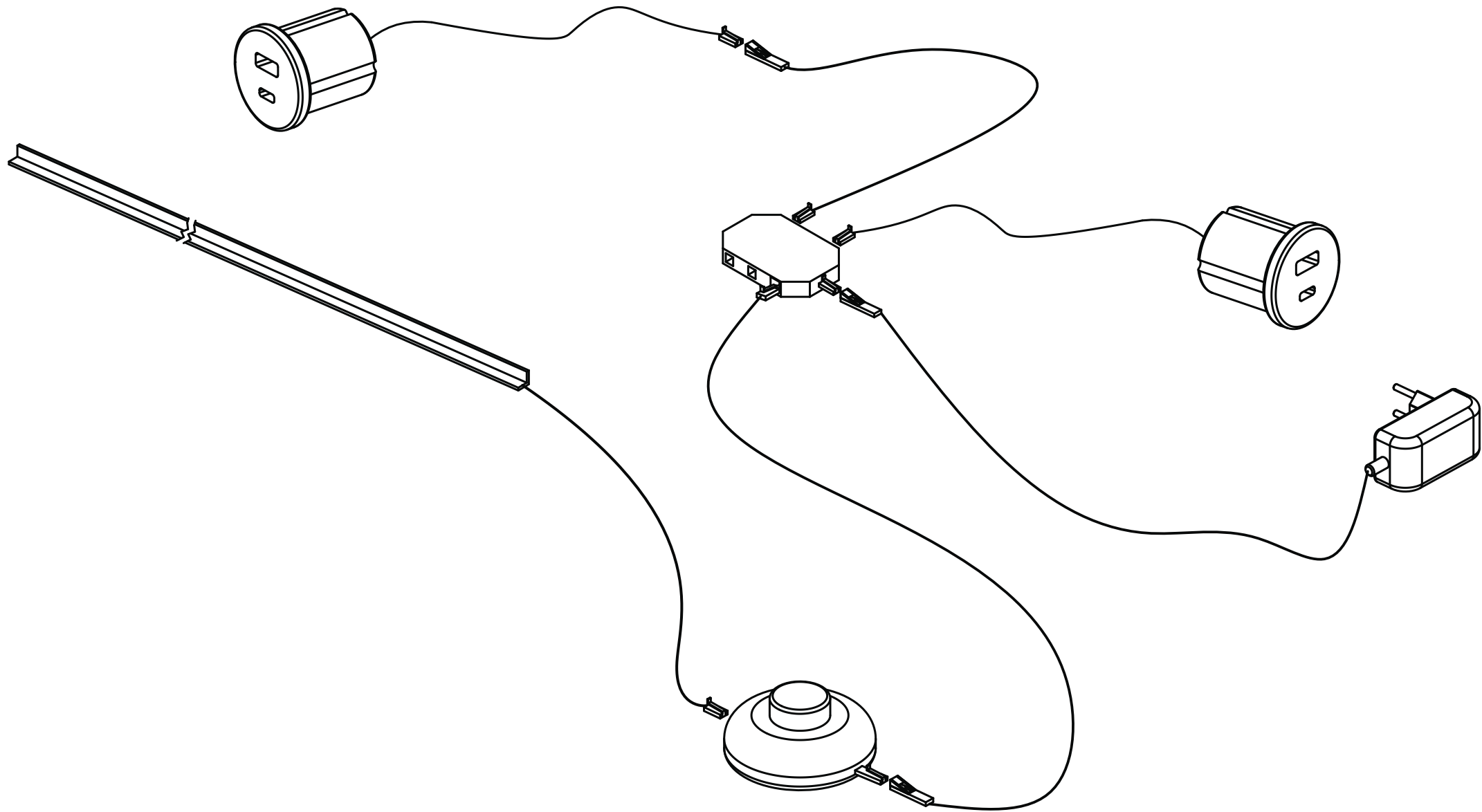

# 21

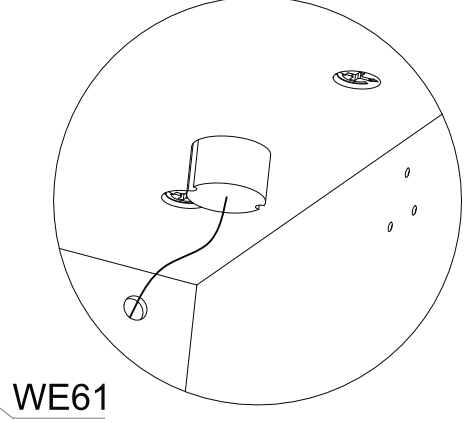
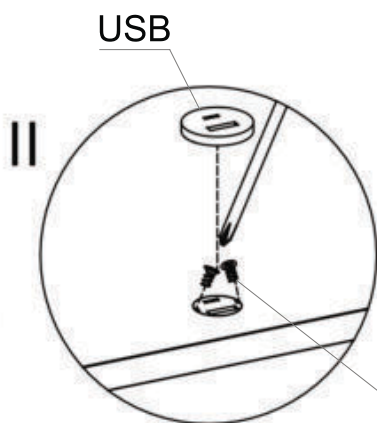
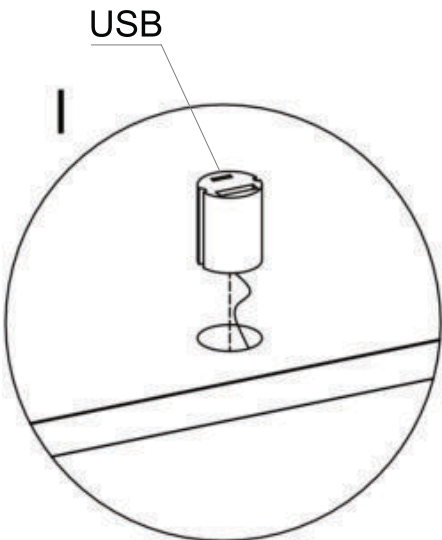
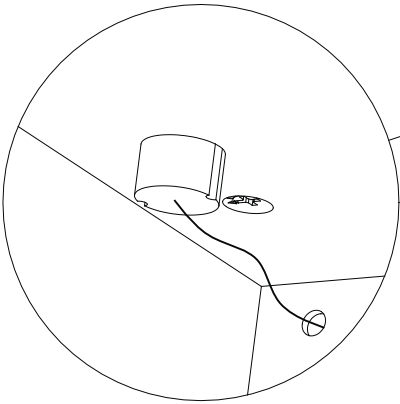
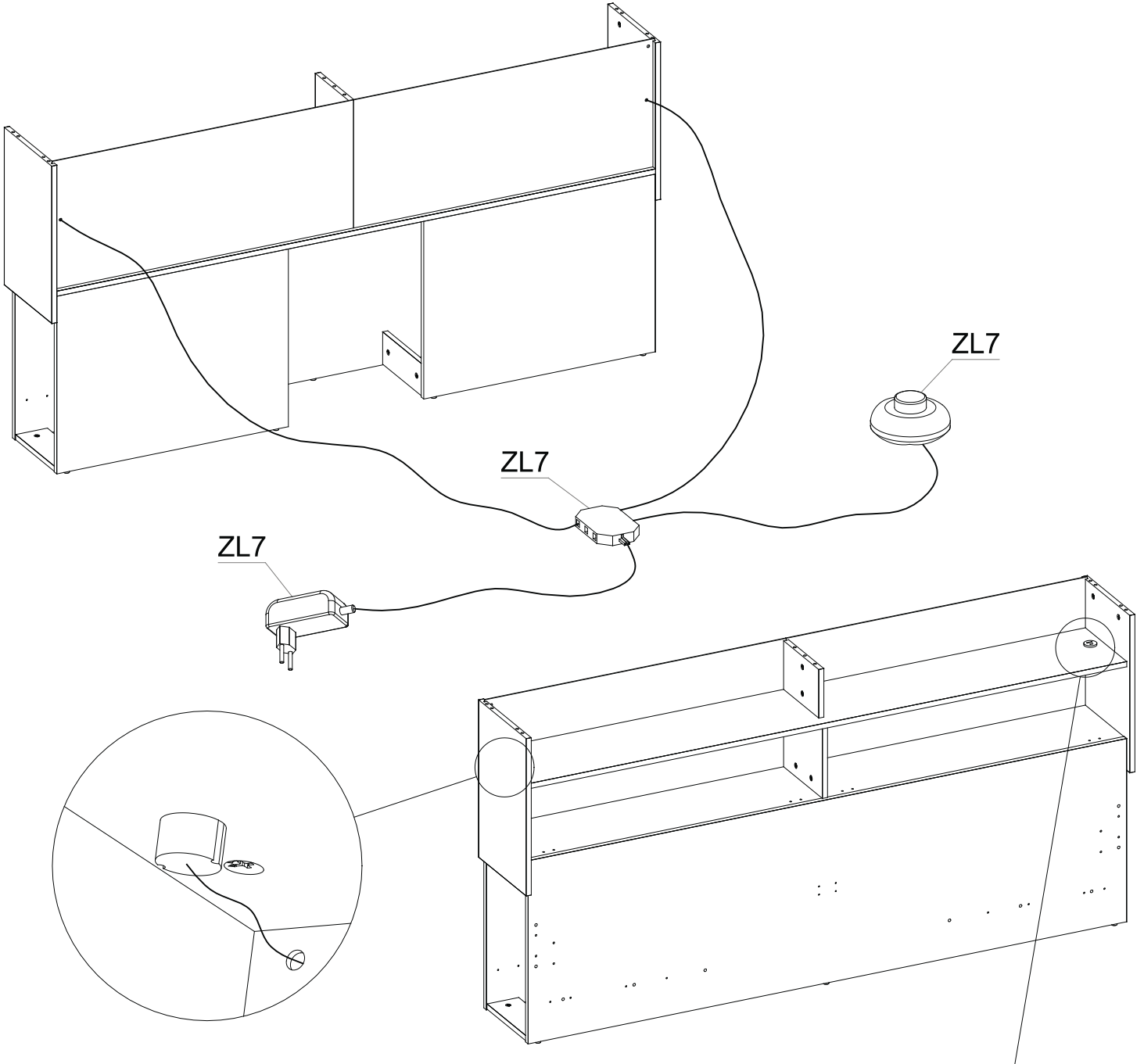
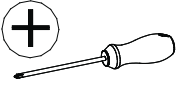
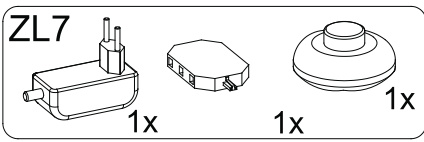
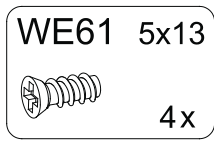
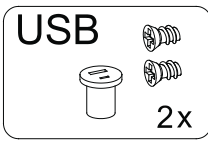

22

ZS12  $\phi 18$   
K-01  
5x

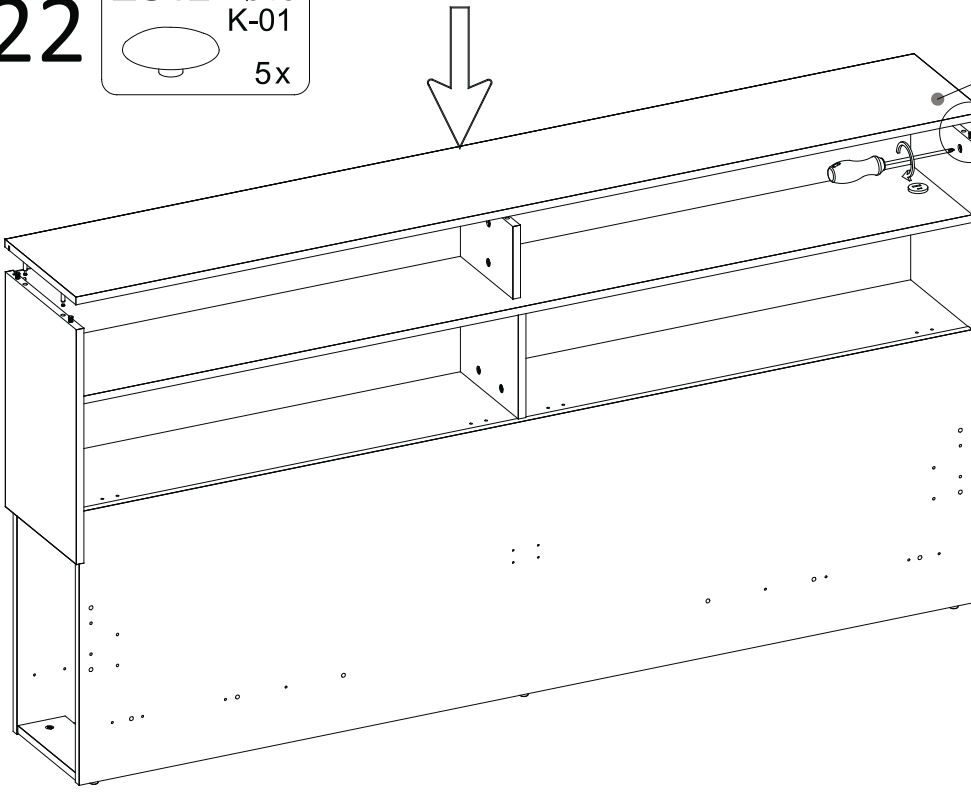

02\_02

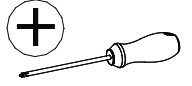

23

G2 2,0x20  
20x

PG  
3x

TK  
24x

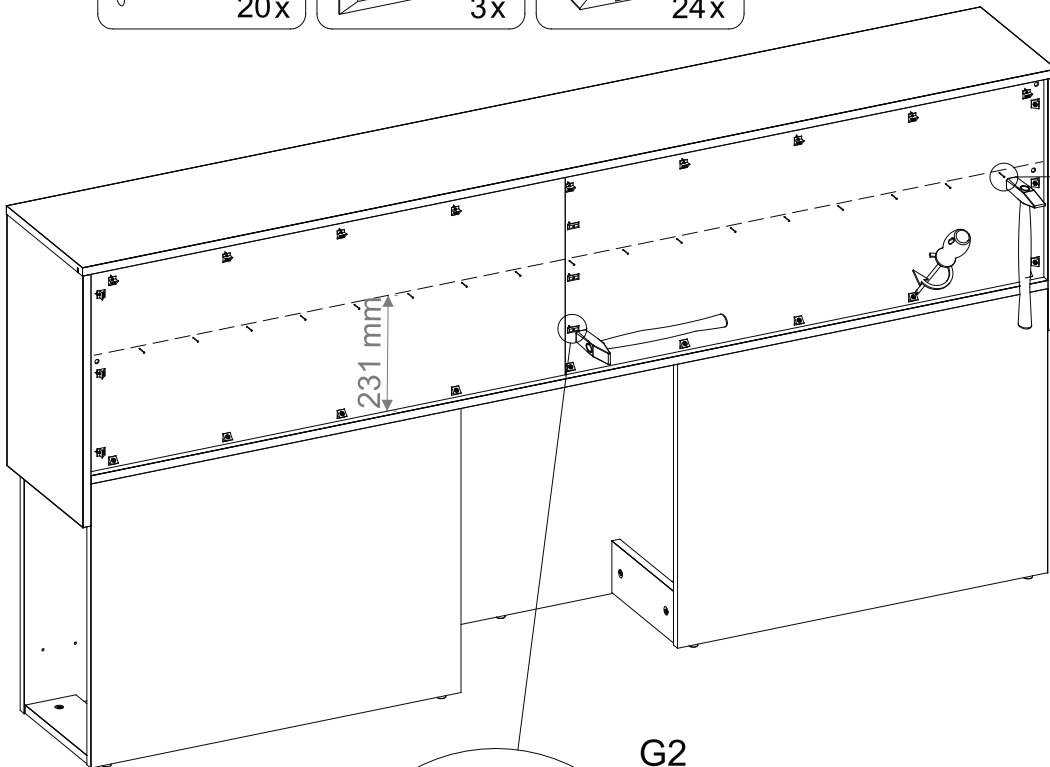

231 mm

G2

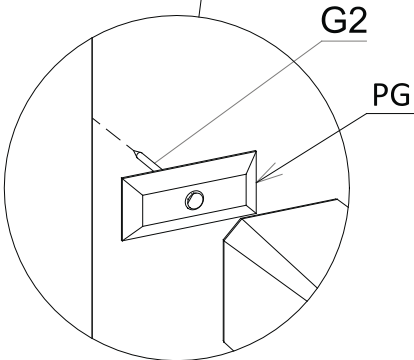
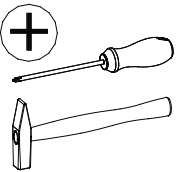

G2

PG

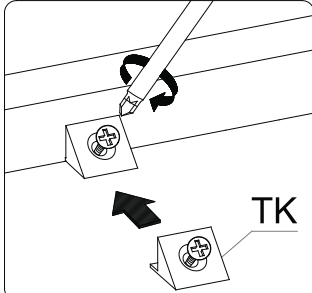

TK

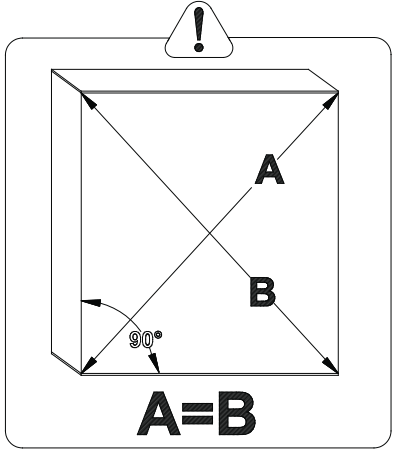

A=B

24

OKS  2x

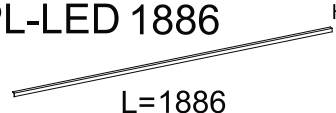
PL-LED 1886  H=10  
L=1886 1x

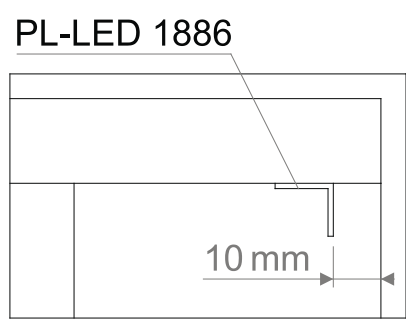
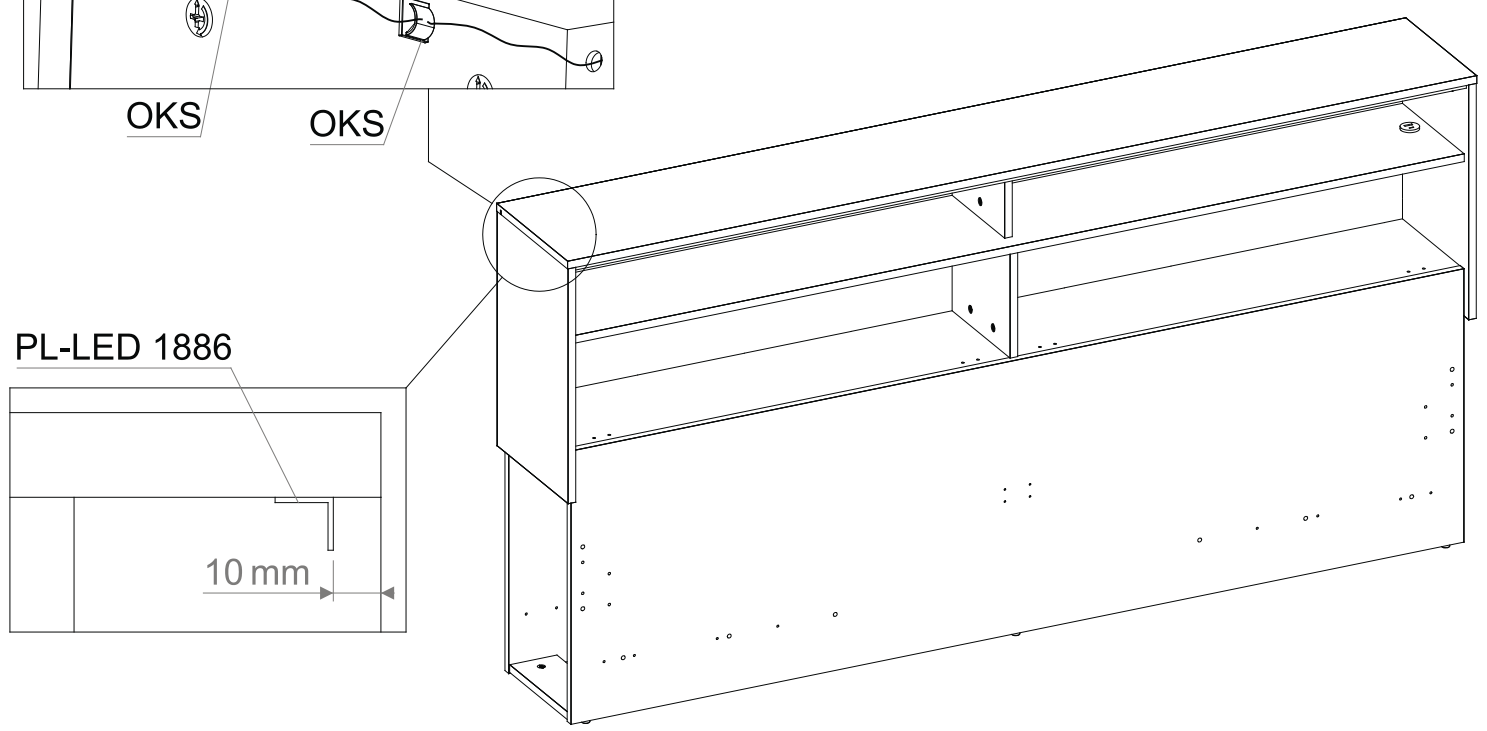
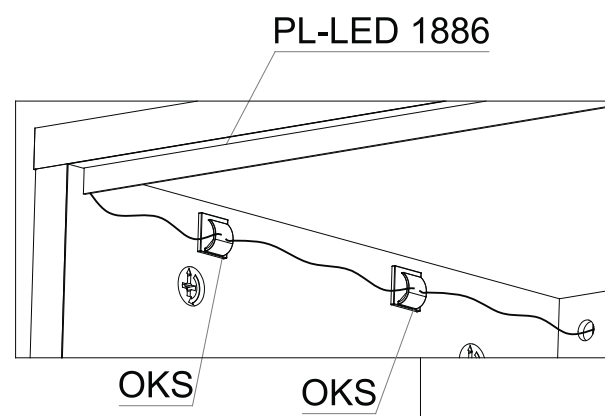
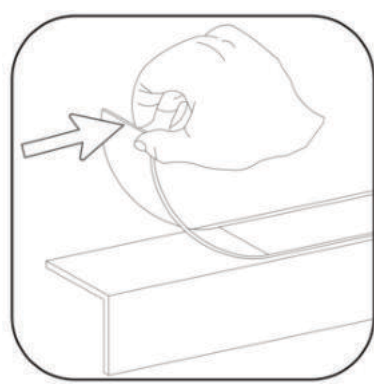
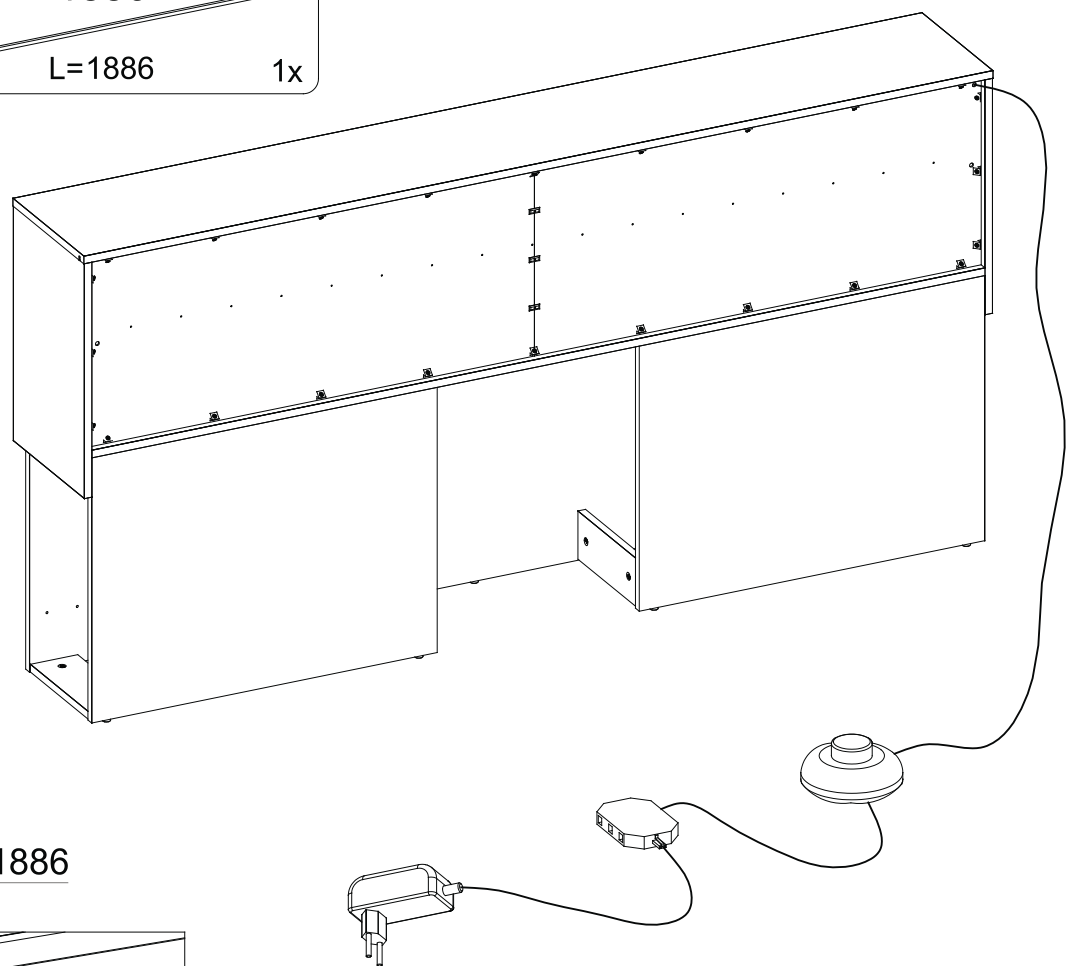

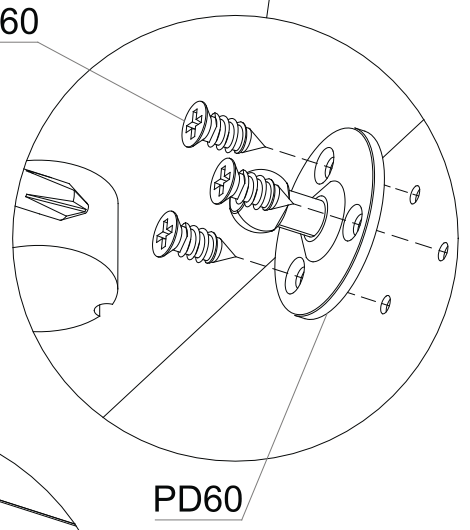
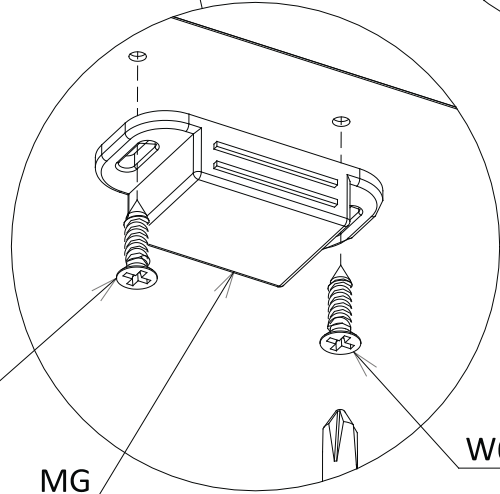
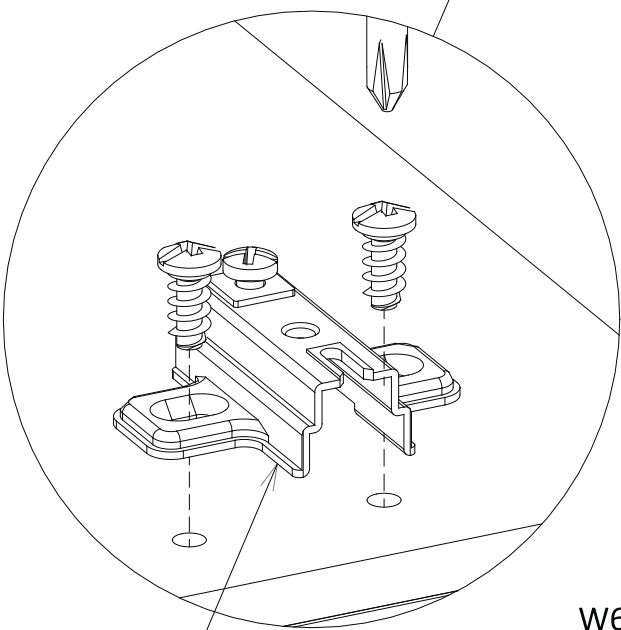
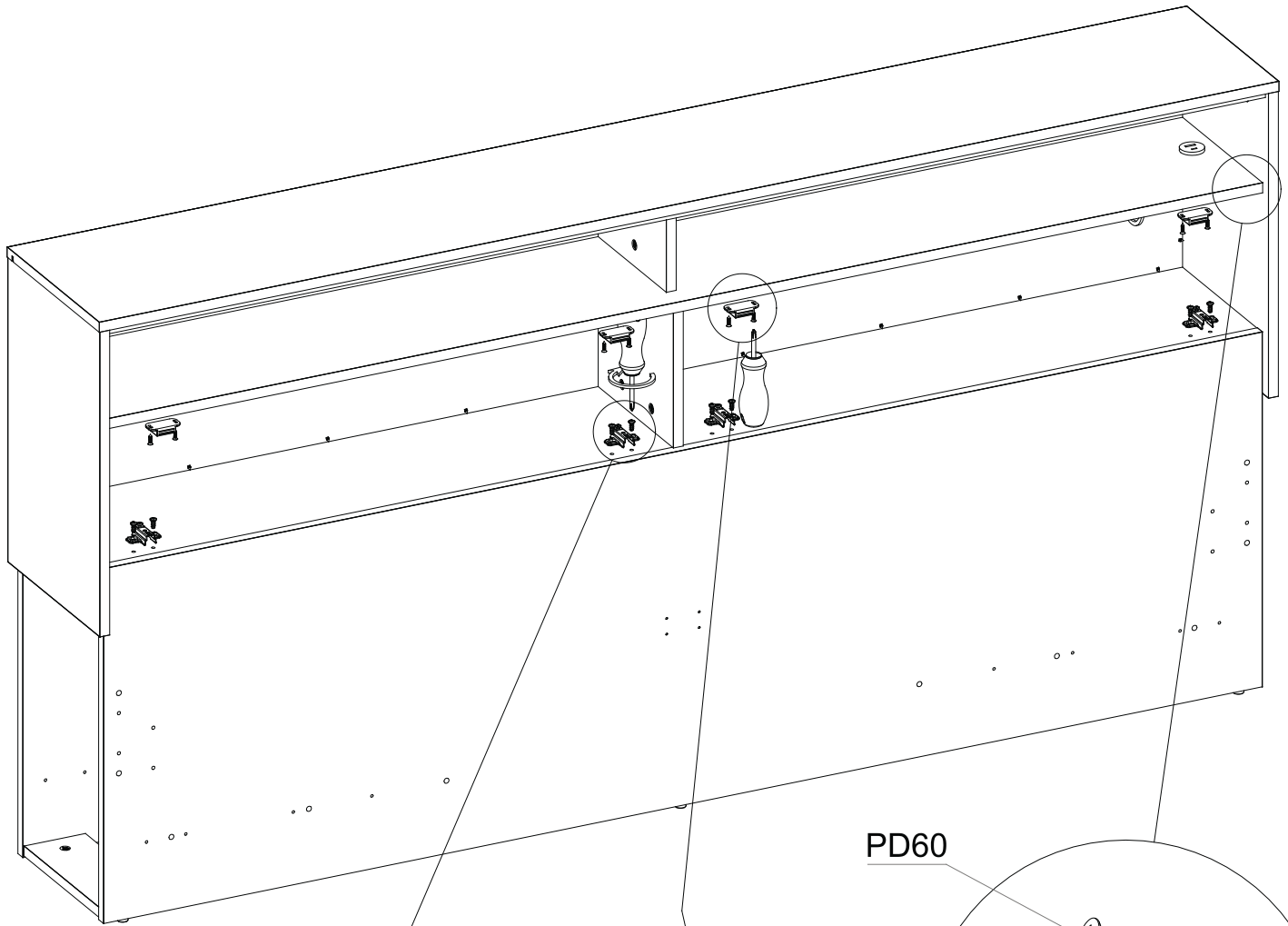
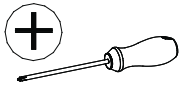
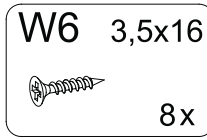
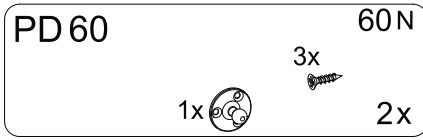
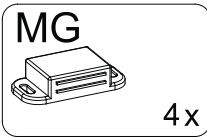
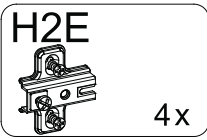

25



# 26

**MG**  
2x

**PD60** 1x  **60N**  
2x  1x

**W2 2,5x13**  
4x

**W7 4x13**  
4x

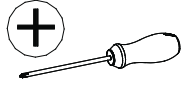

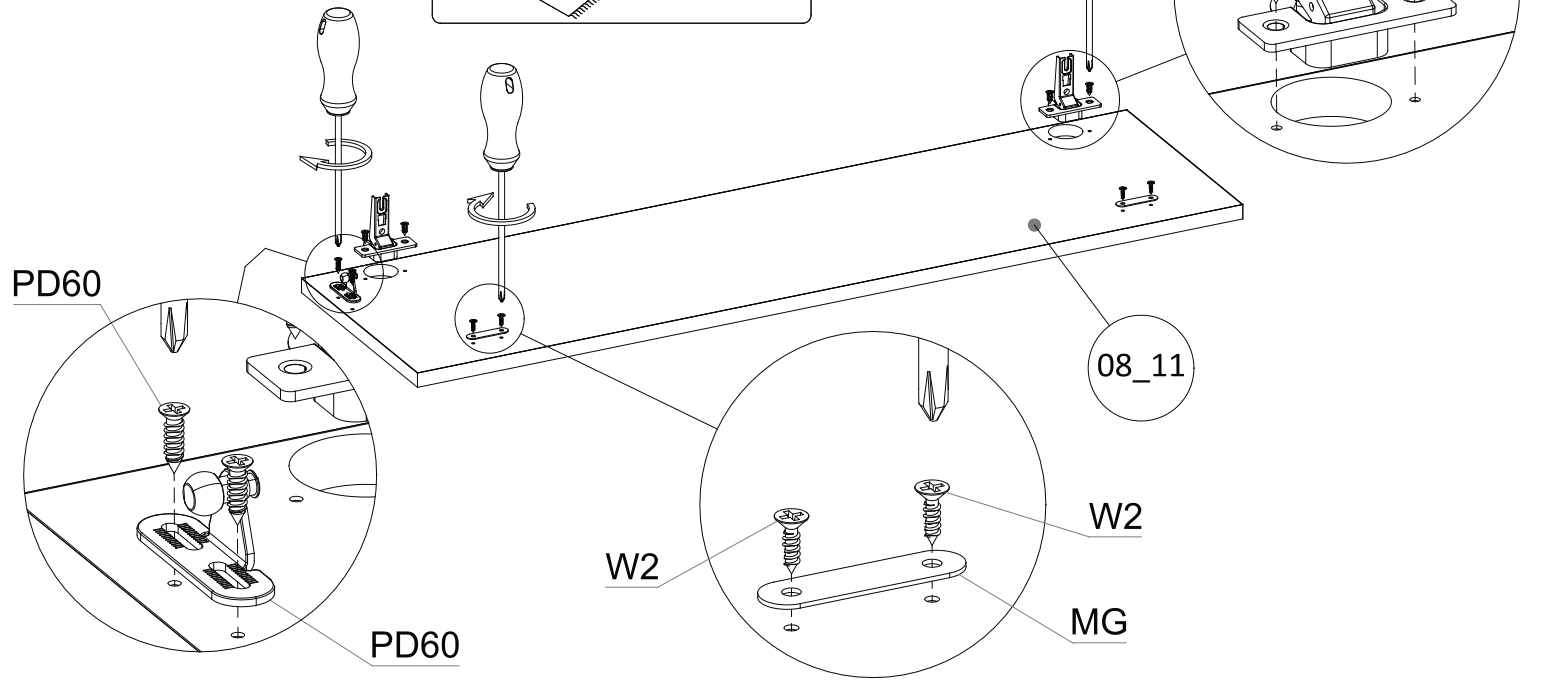
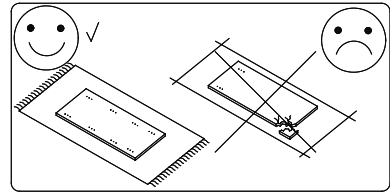

**Z3**  
2x



# 27

**MG**  
2x

**PD60** 1x  **60N**  
2x  1x

**W2 2,5x13**  
4x

**W7 4x13**  
4x

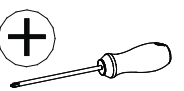

**Z3**  
2x

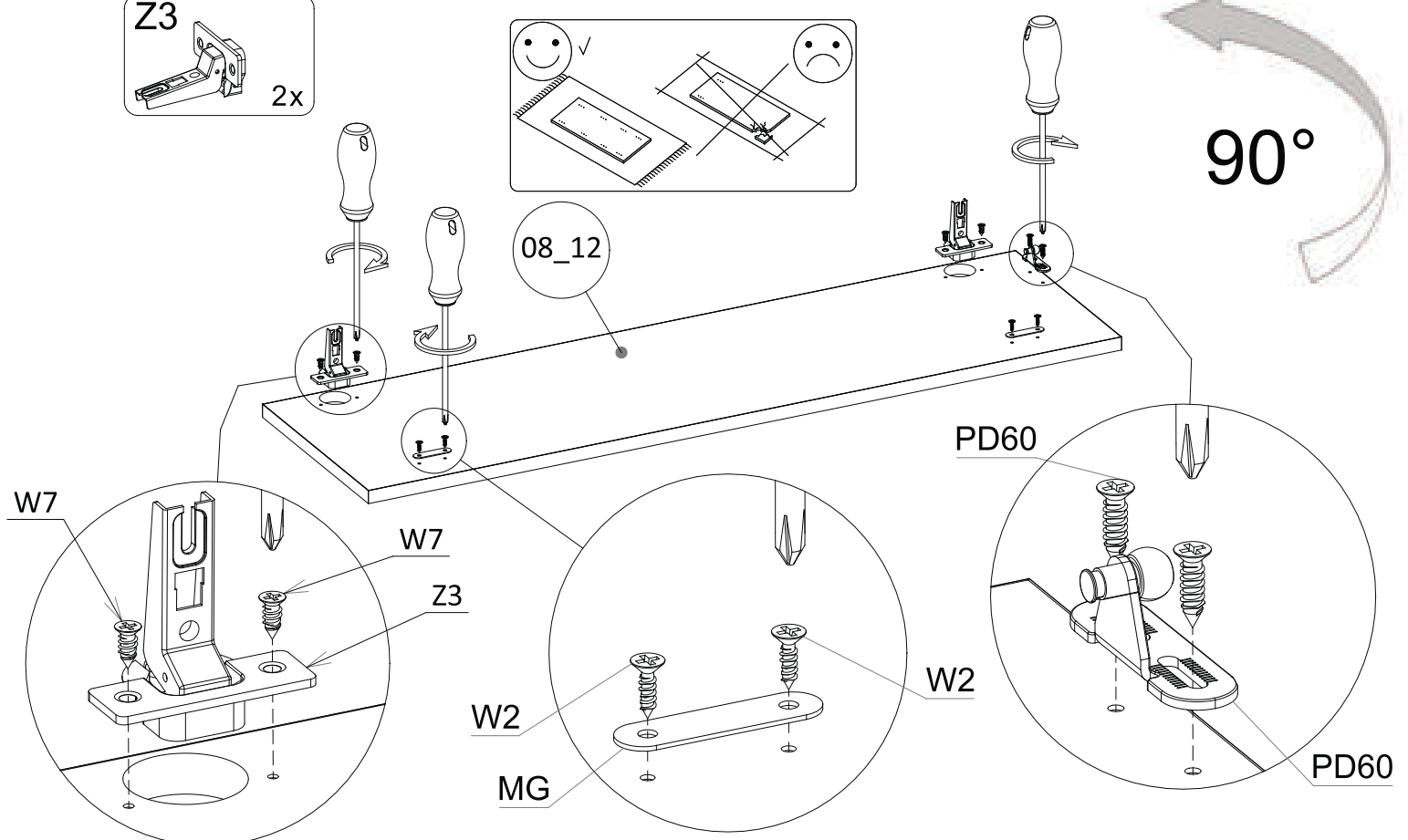
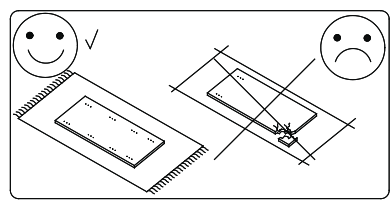

# 28

- PD 60 1x
- 60N 2x

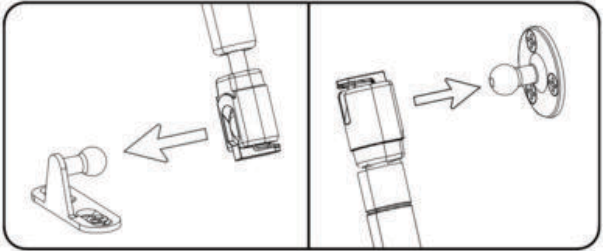
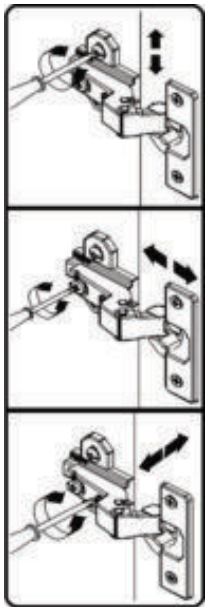
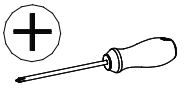
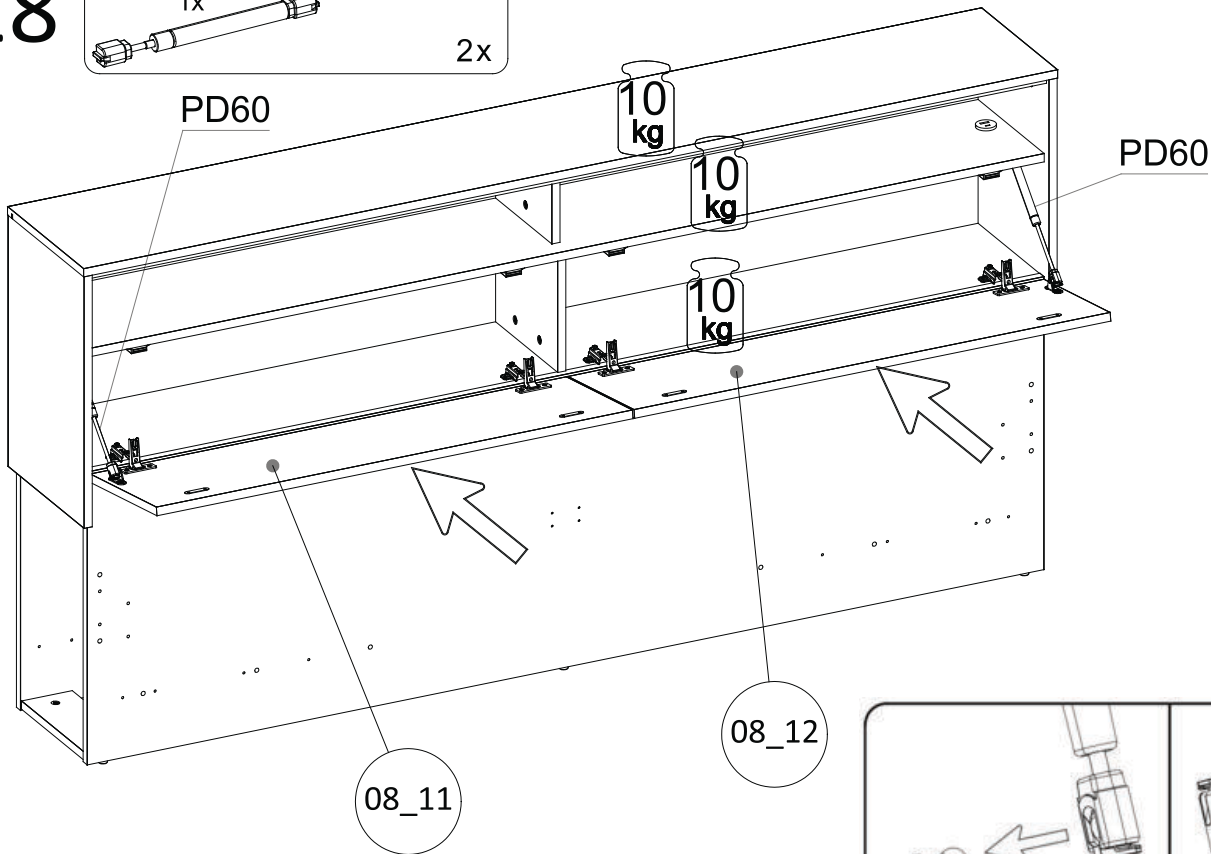

# 29

- TM1 4x
- ZL 1x
- W6 3,5x16 4x

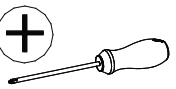
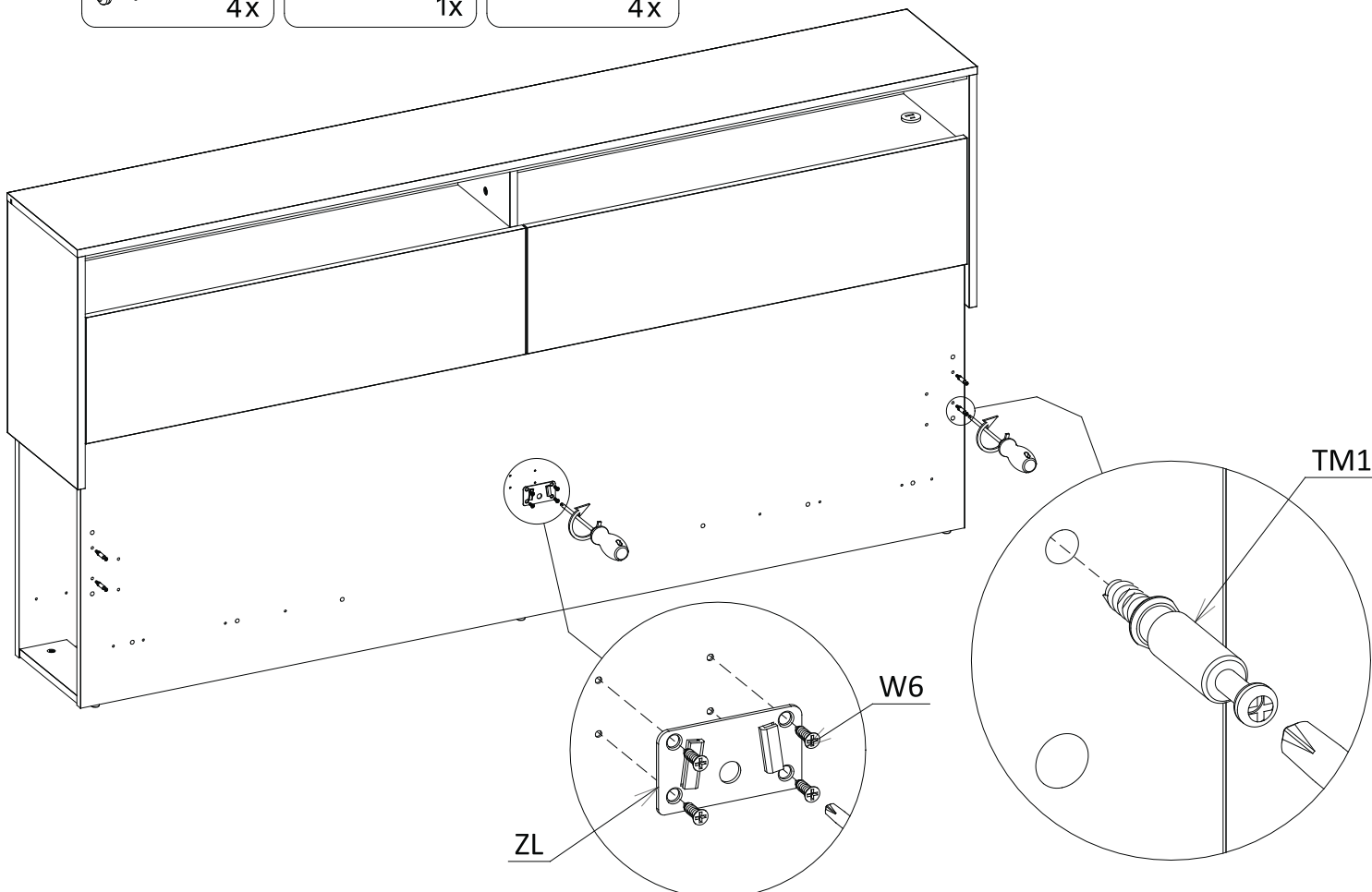

# 30

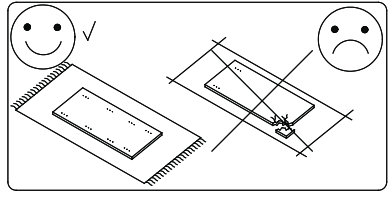
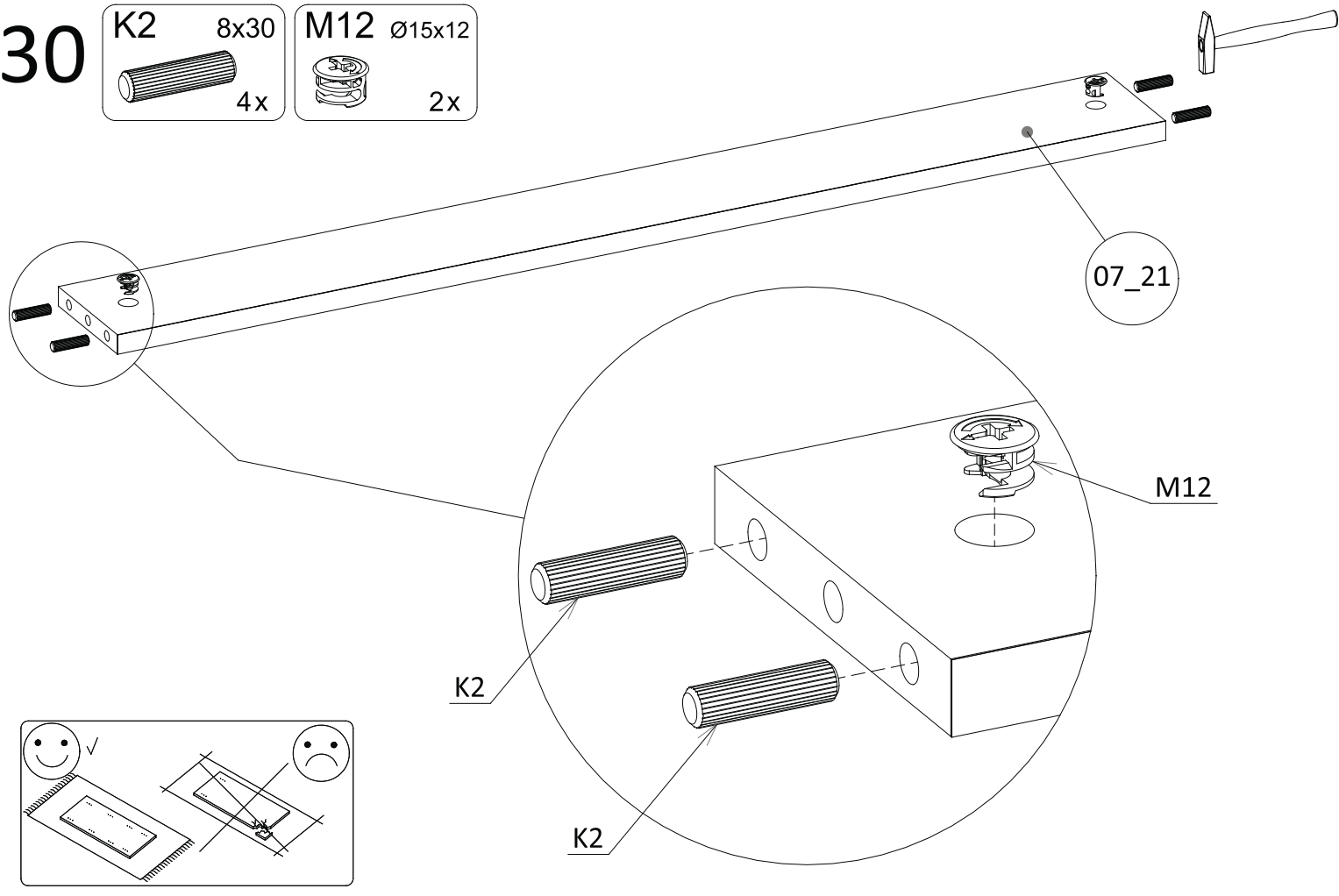
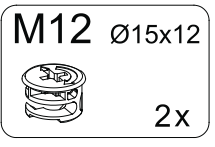
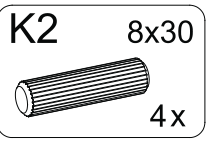

# 31

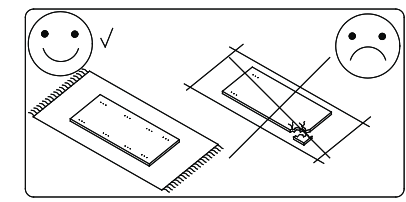
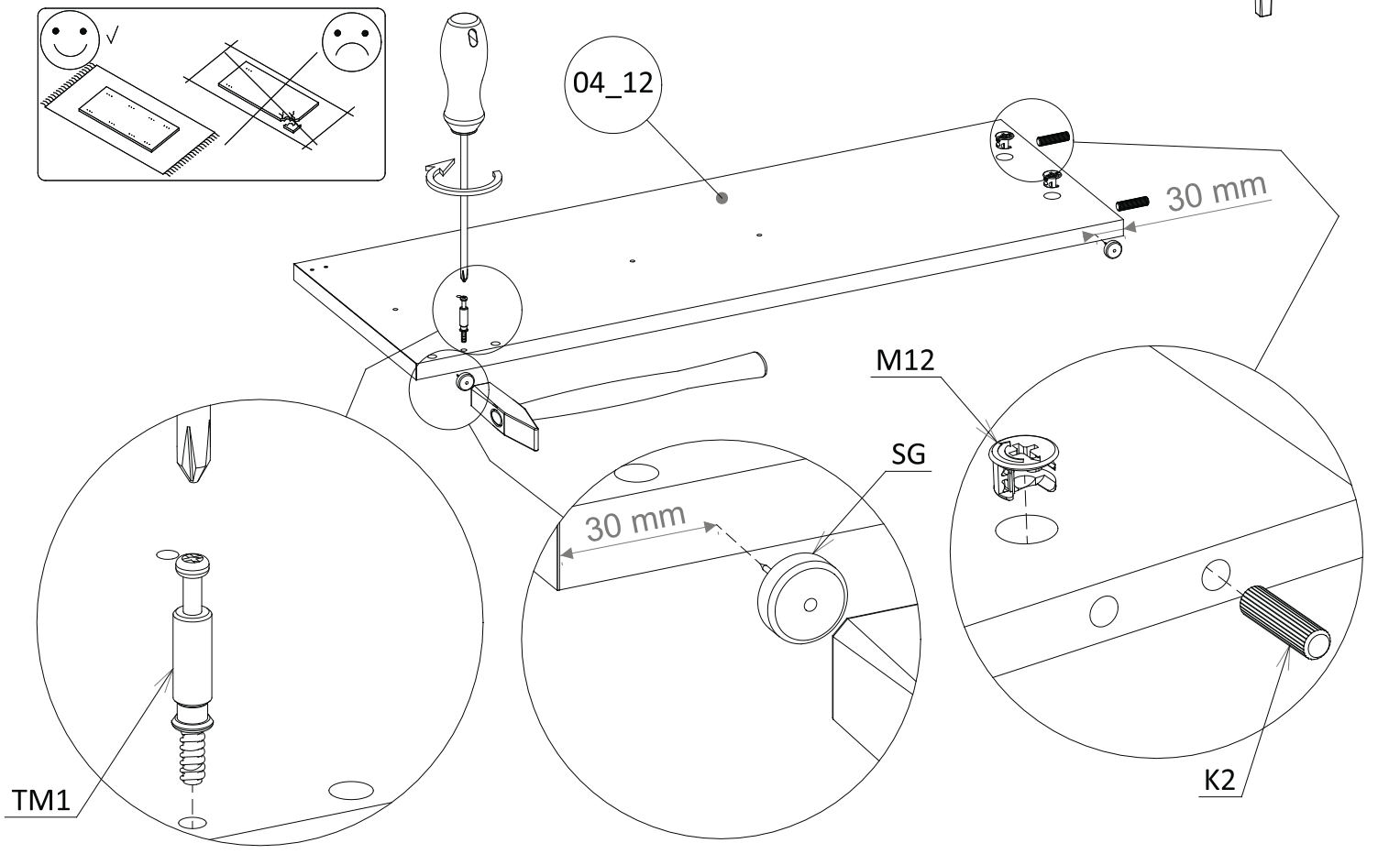
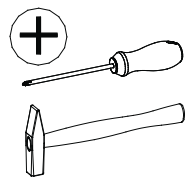
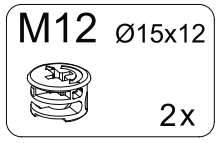
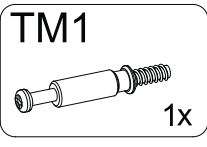
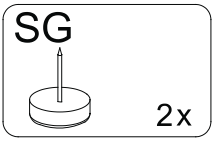
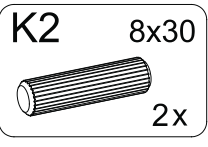

# 32

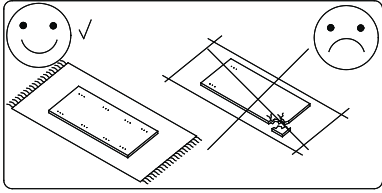
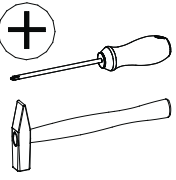
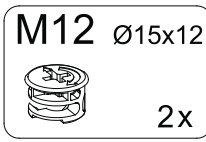
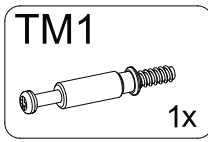
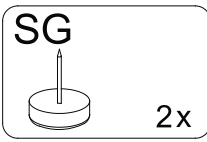
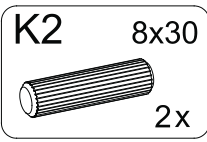

04\_13

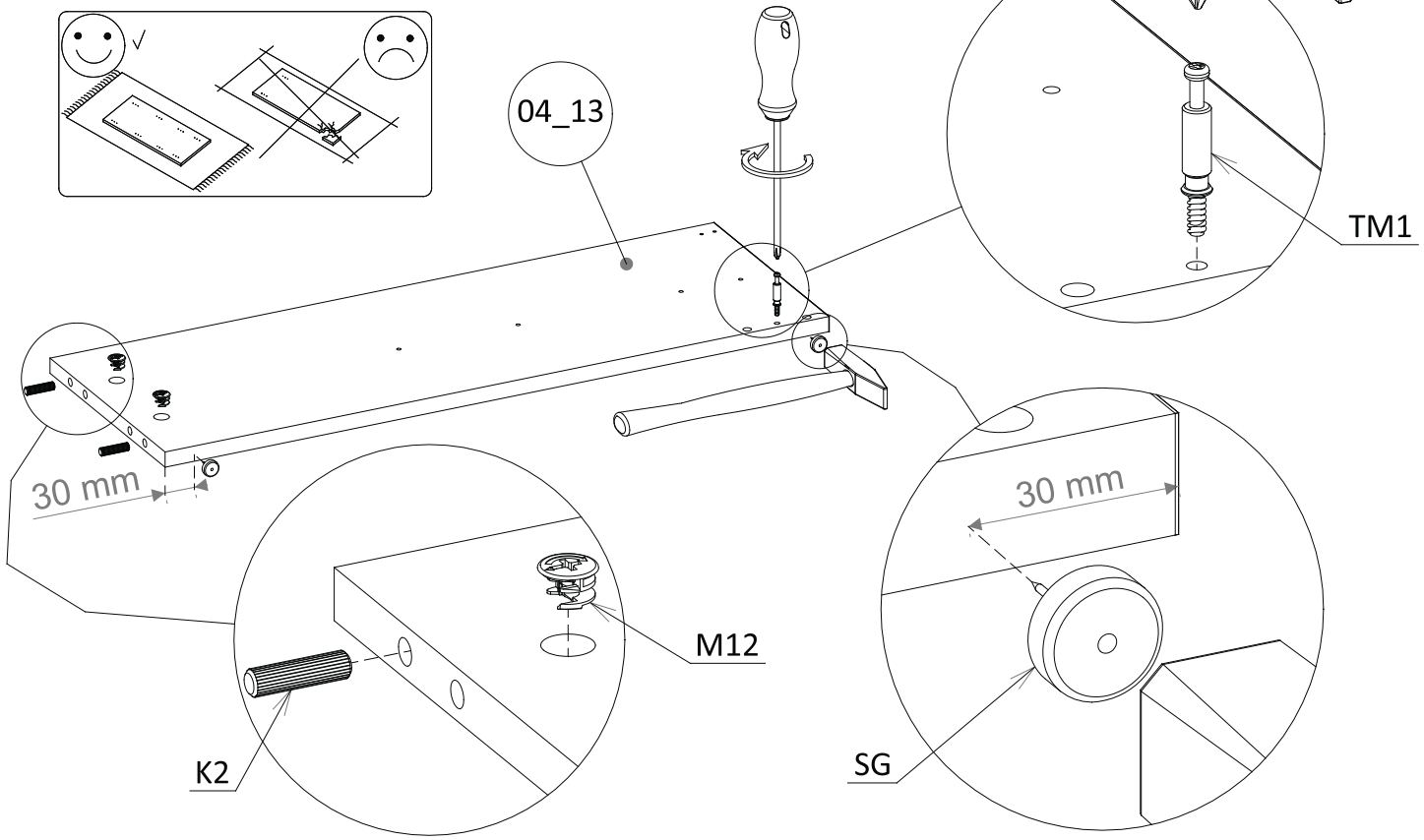

# 33

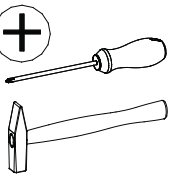
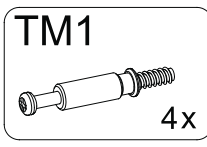
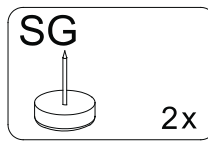

04\_11

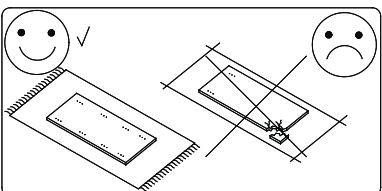
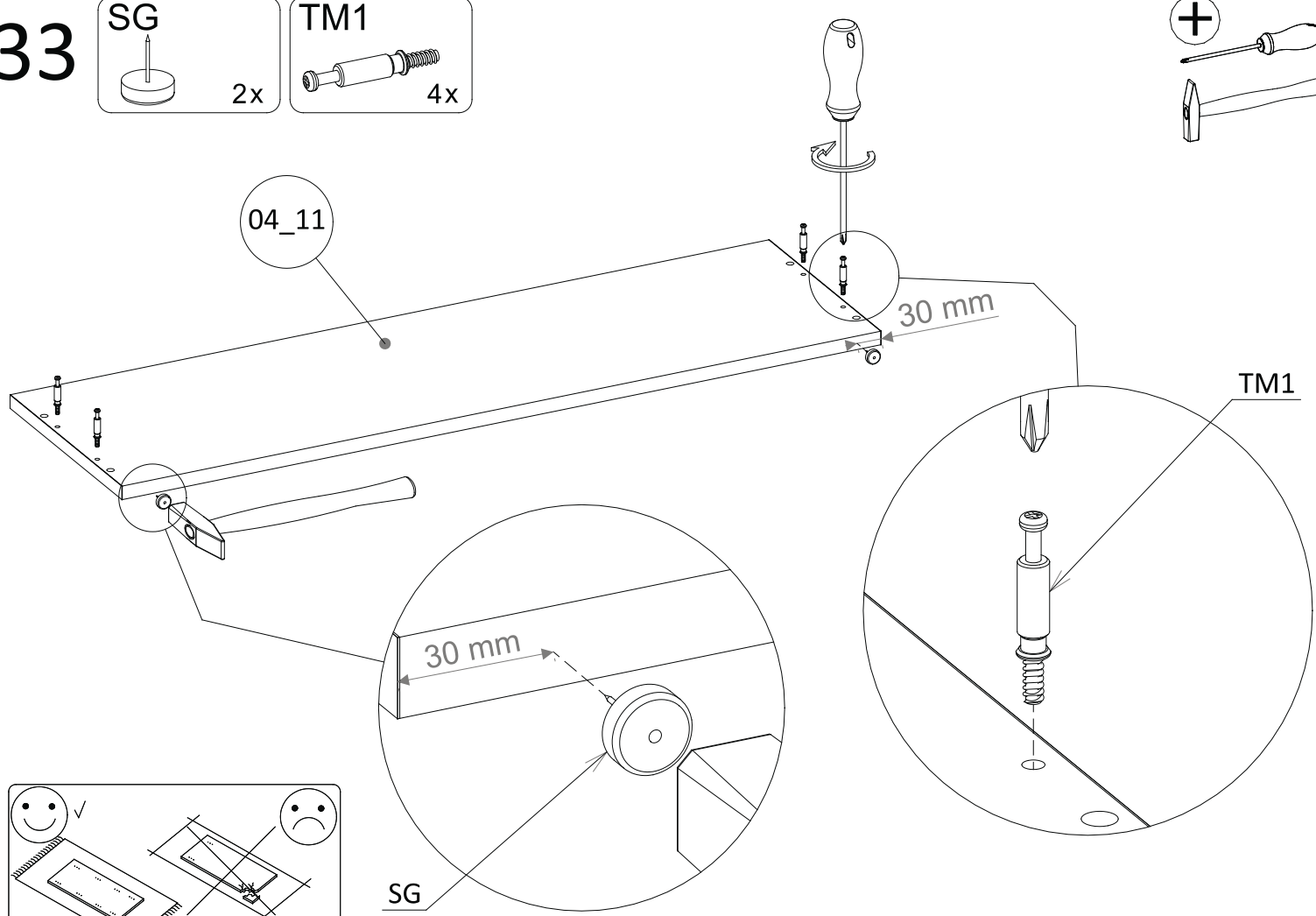

# 34

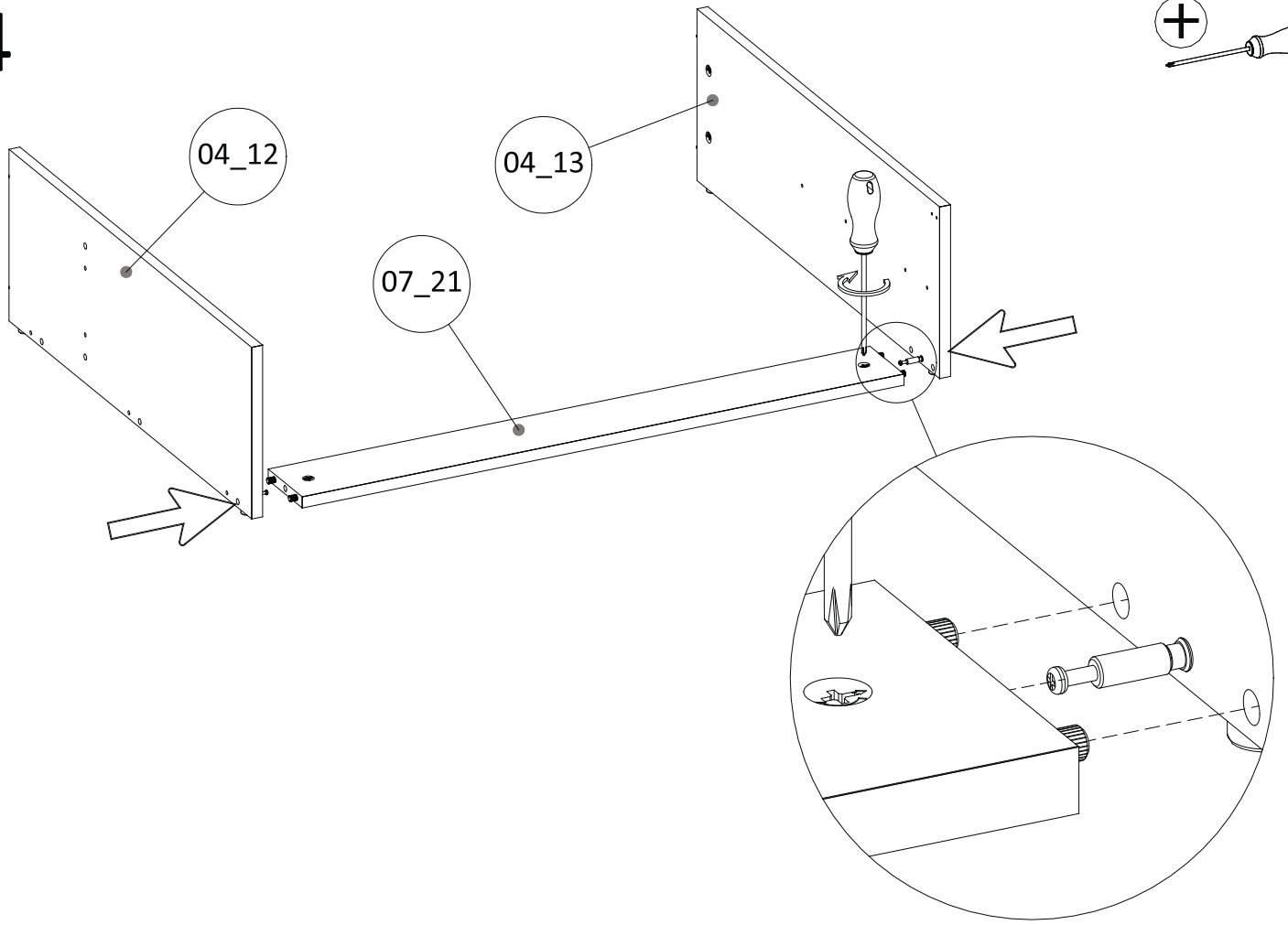
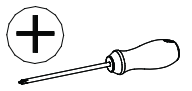

# 35

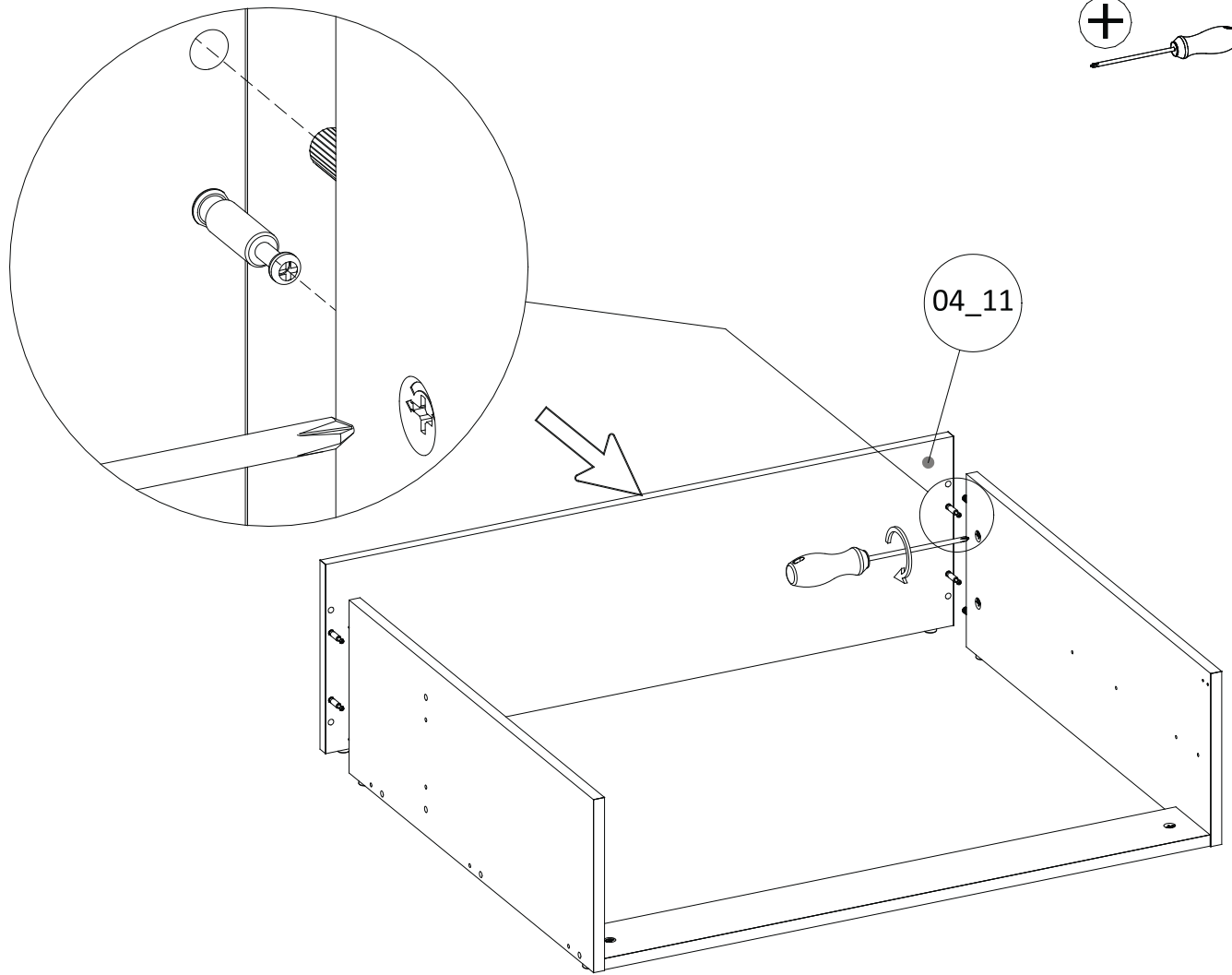
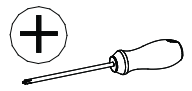

# 36

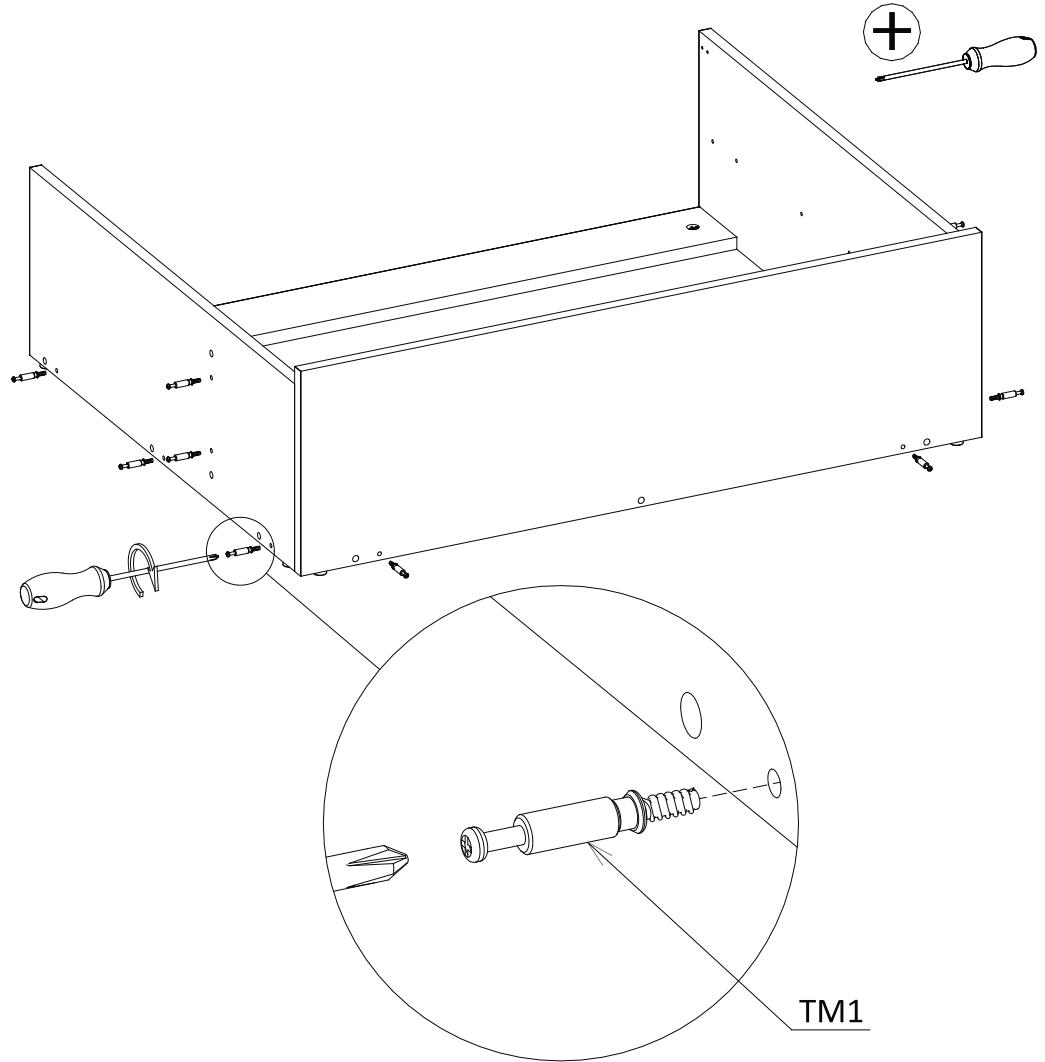
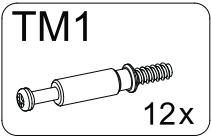

# 37

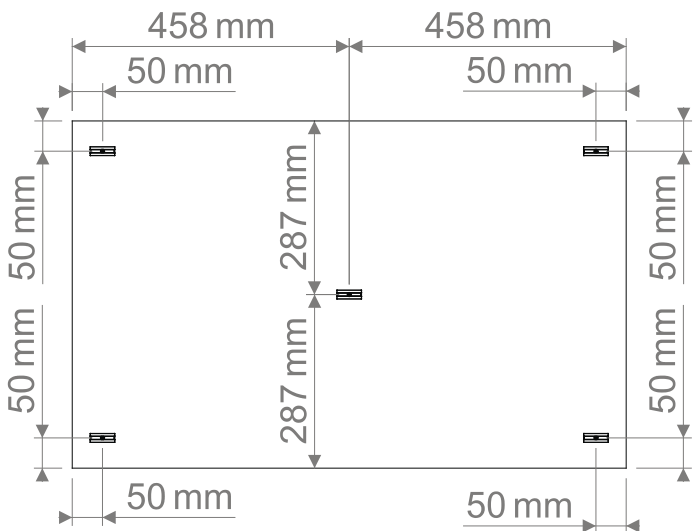
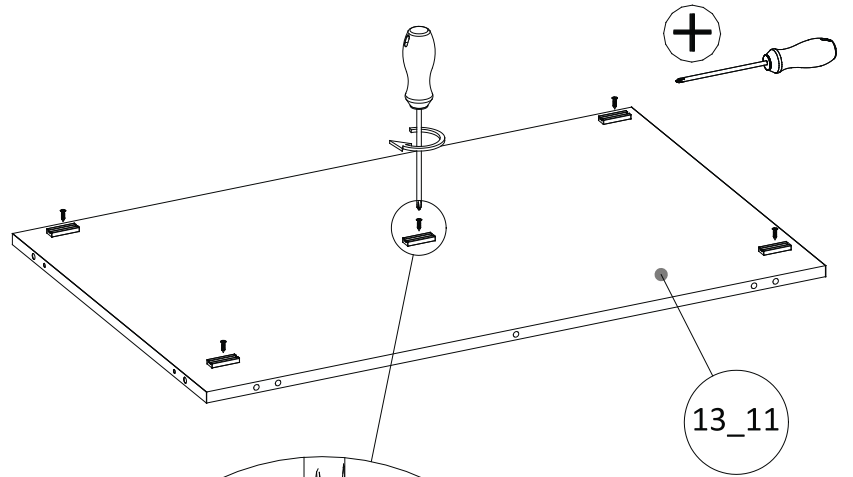
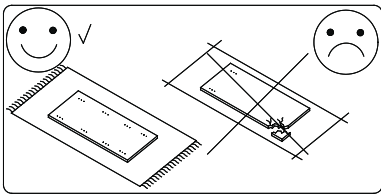
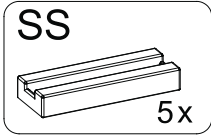
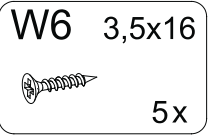

# 180°

# 38

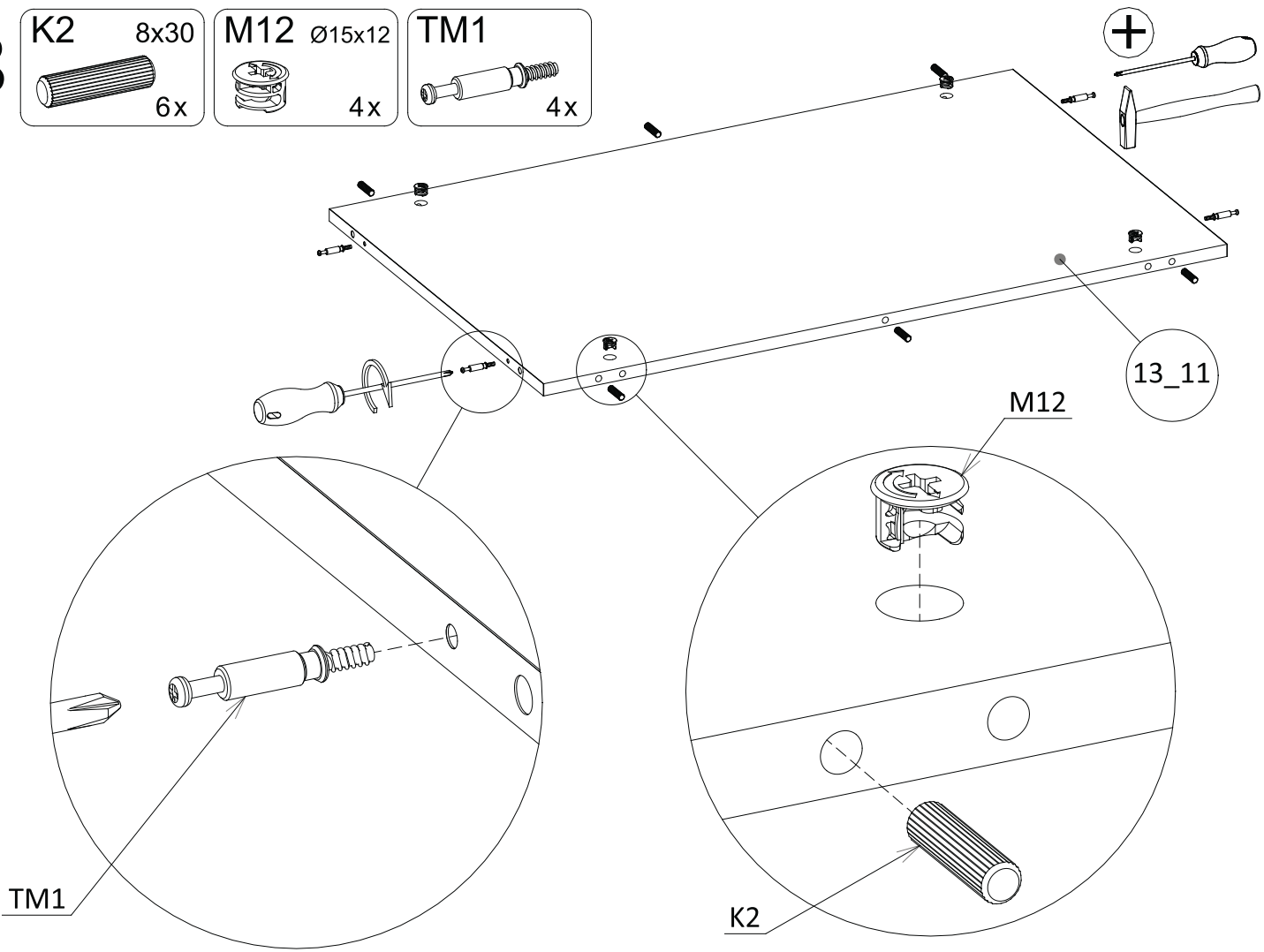
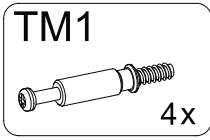
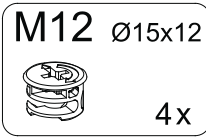
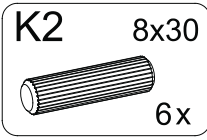

# 39

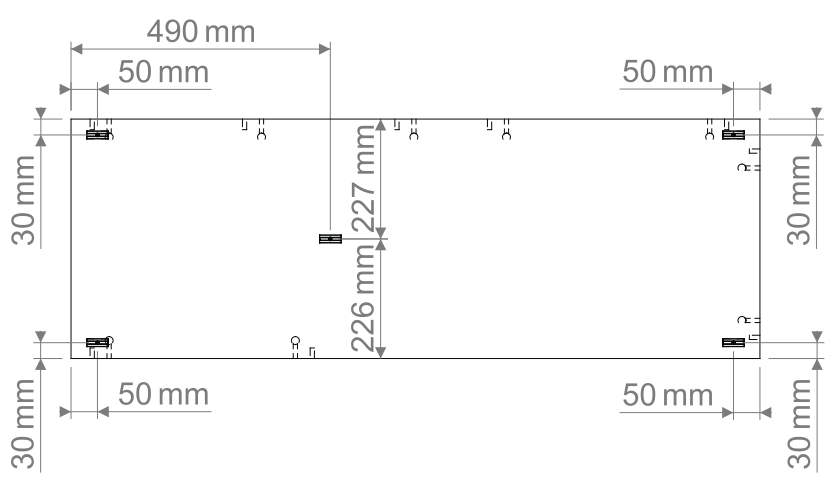
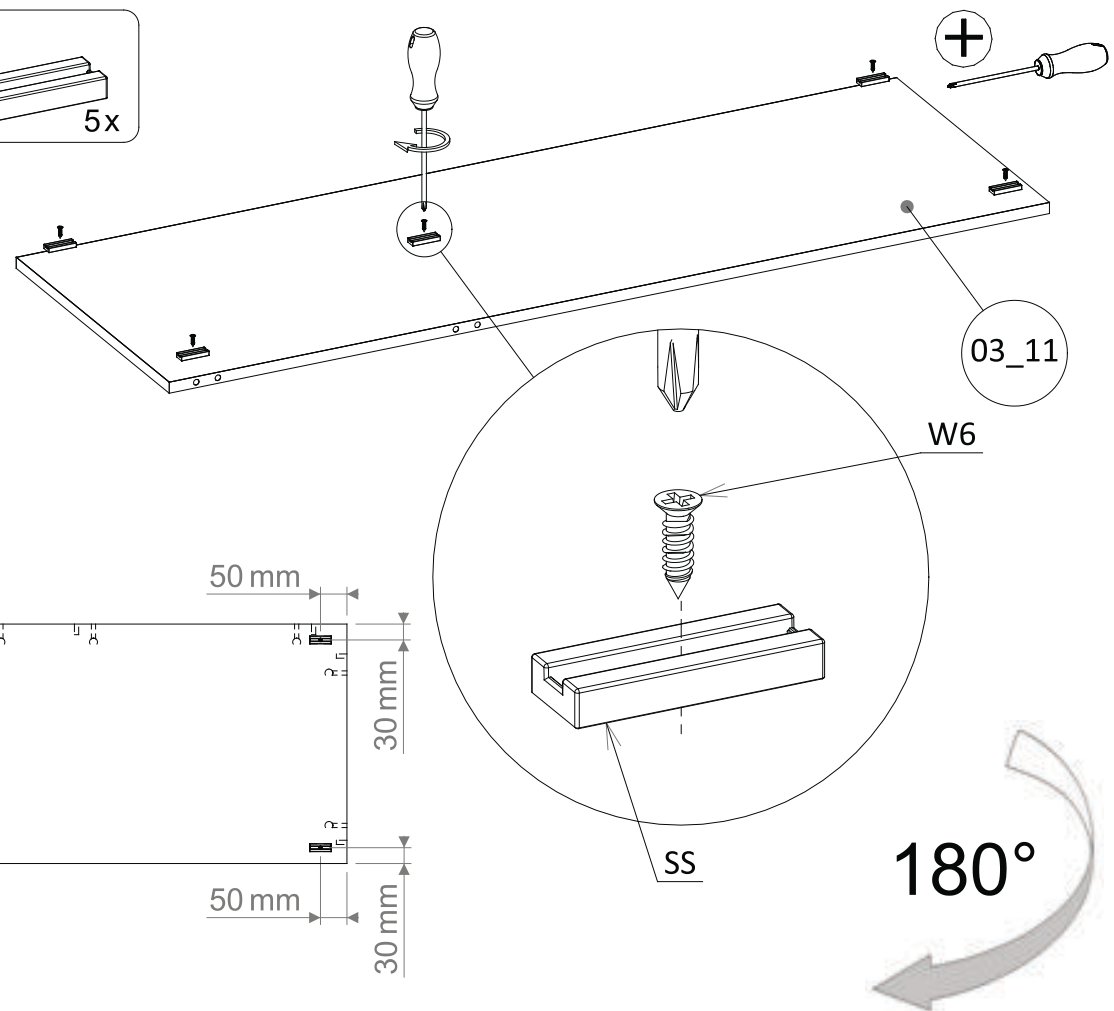
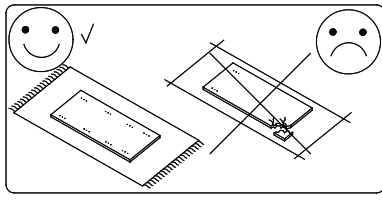
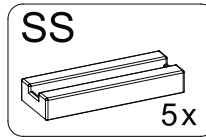
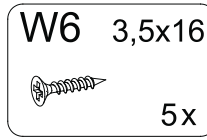

# 40

- K2** 8x30 9x
- M12** Ø15x12 9x

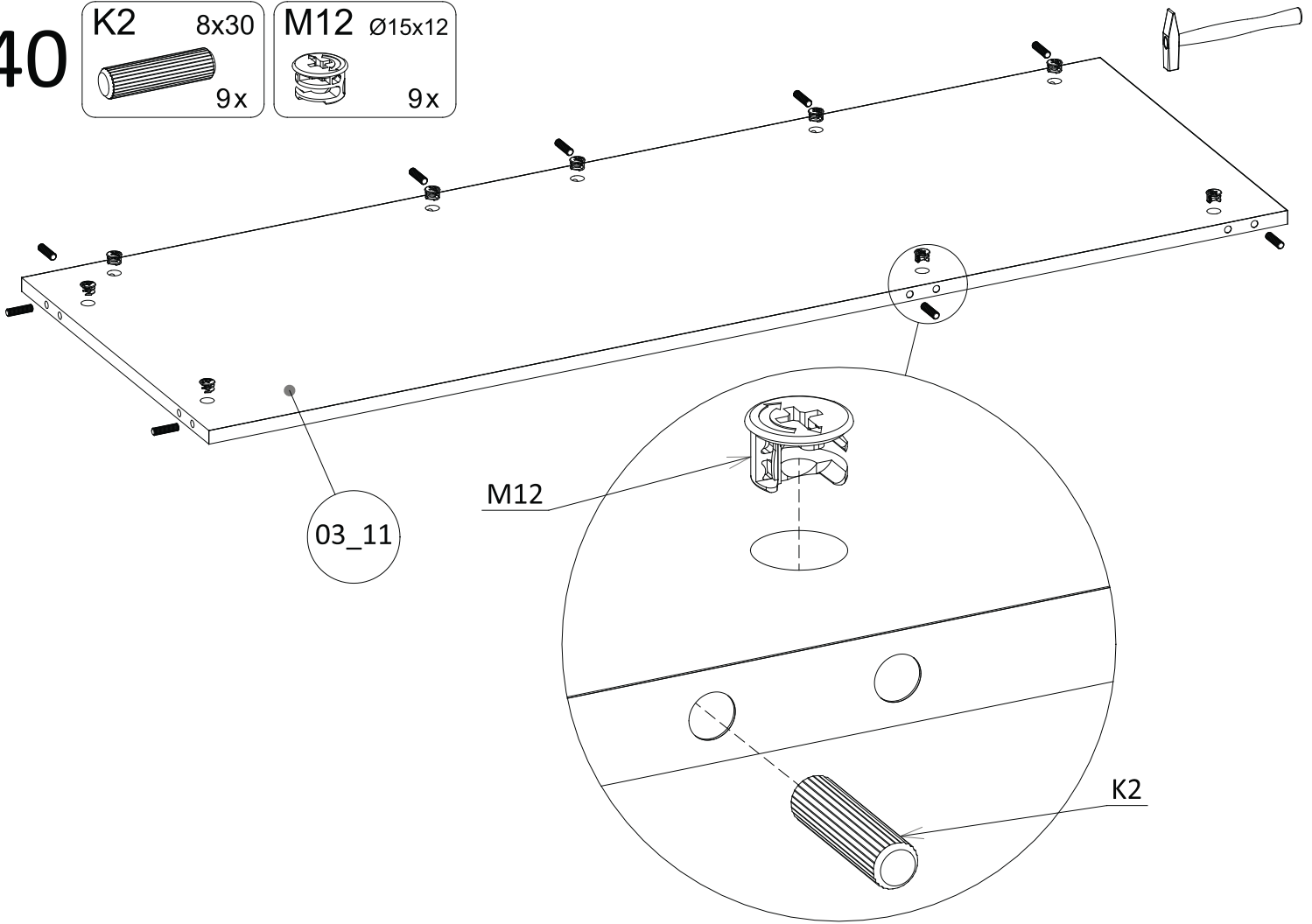

# 41

- W6** 3,5x16 5x
- SS** 5x

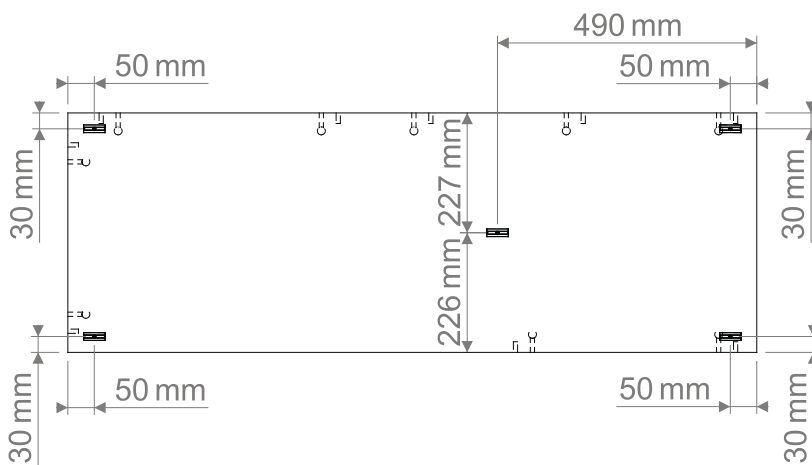
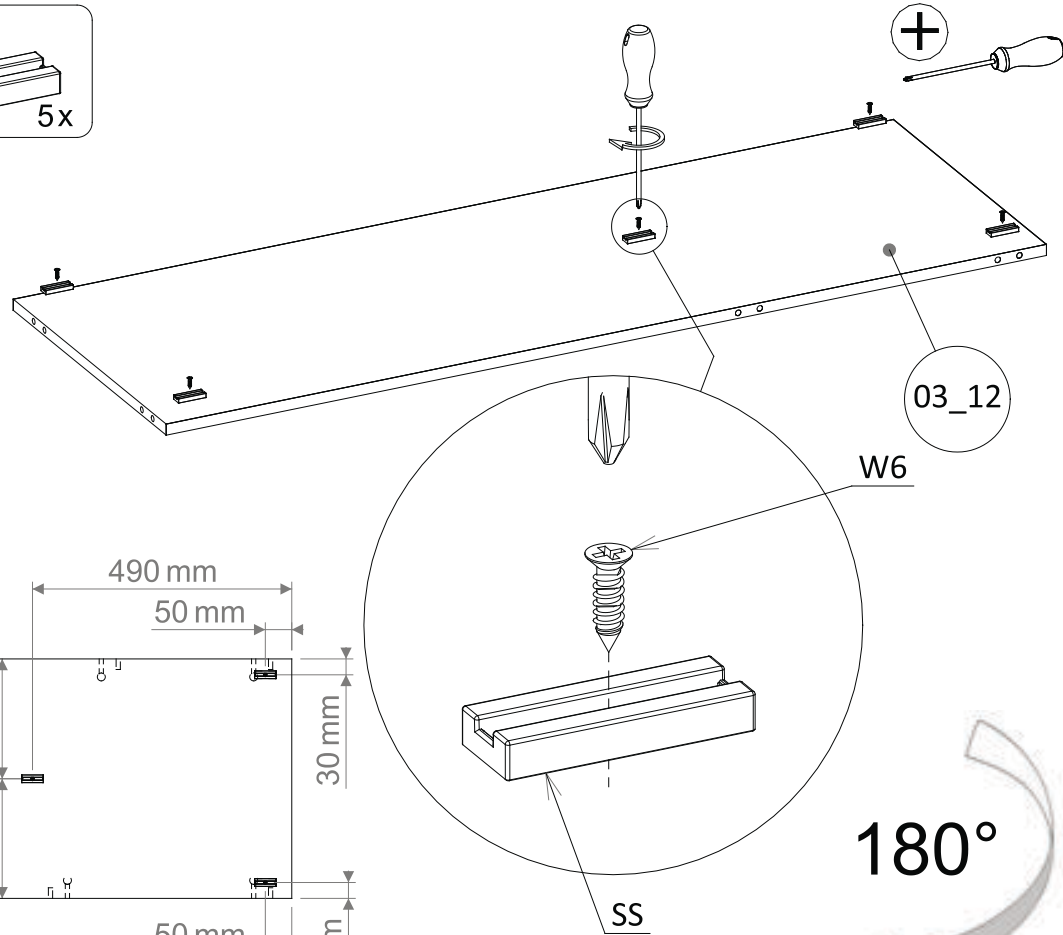
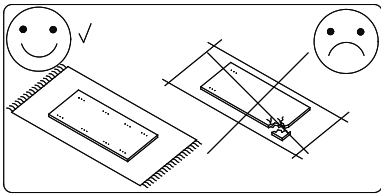

# 180°

# 42

**K2** 8x30  
9x

**M12** Ø15x12  
9x

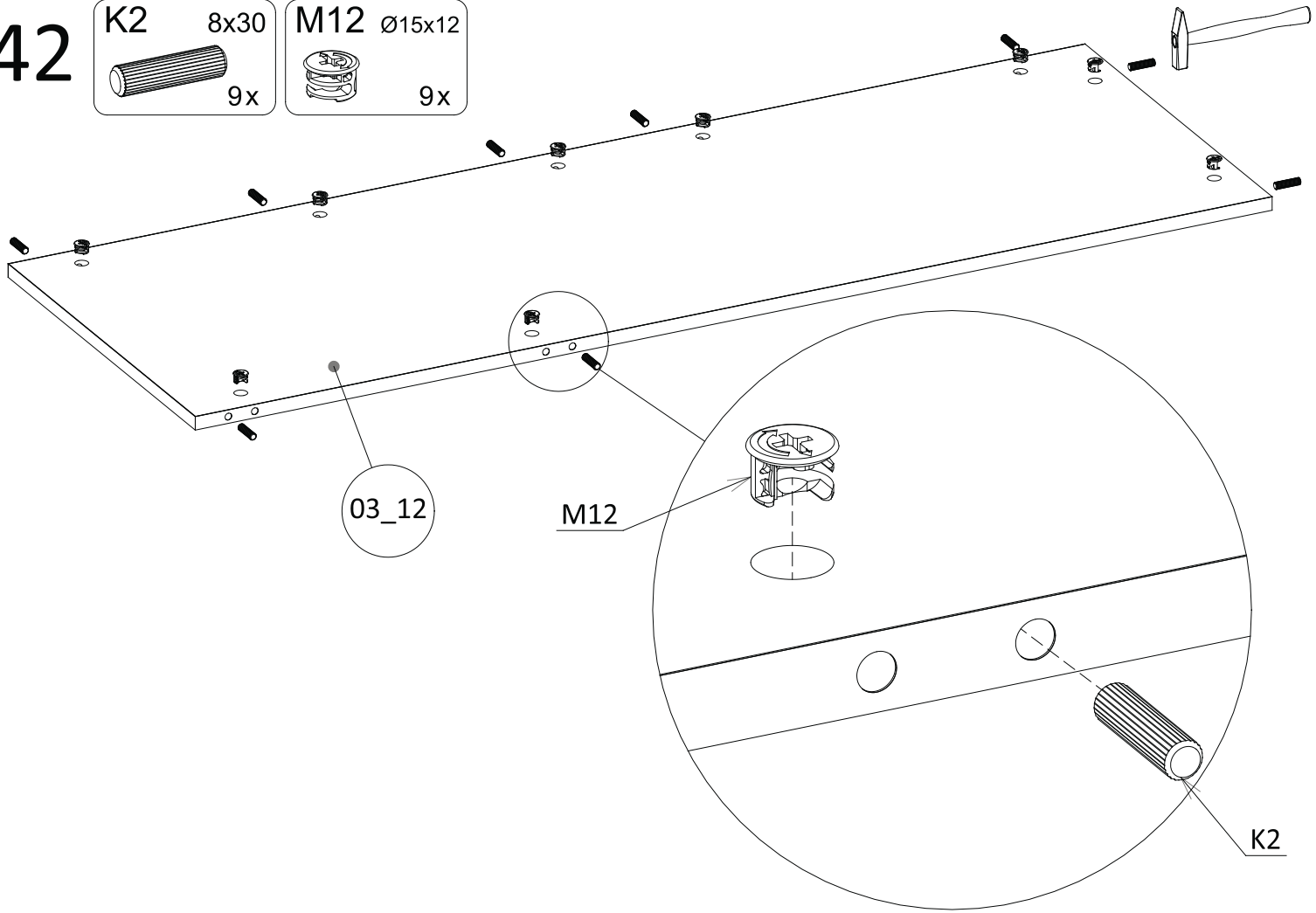

# 43

**ZS12** ø18  
K-01  
2x

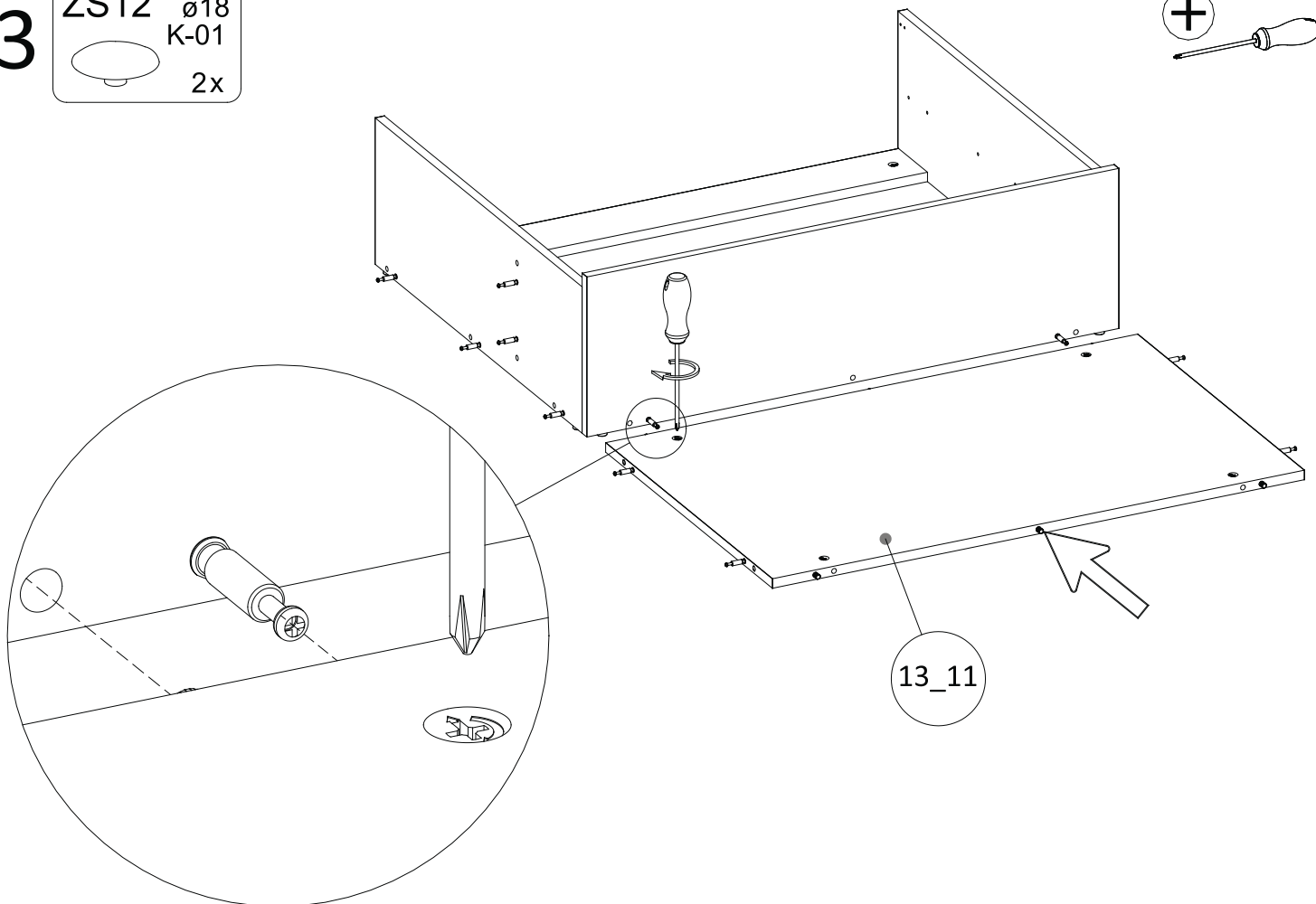
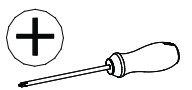

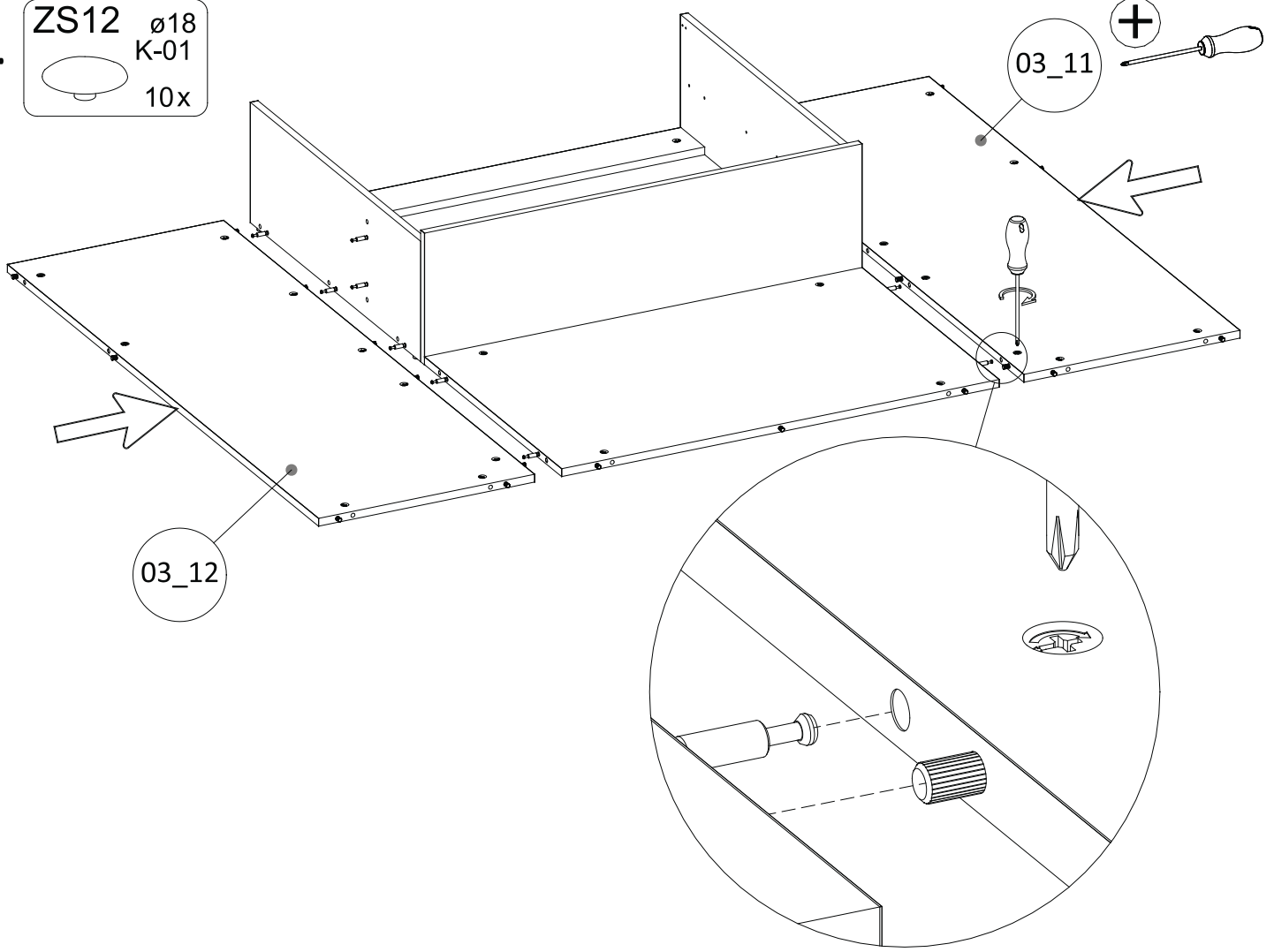

44

ZS12	∅18
K-01	
	10x

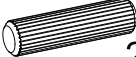

45

K2	8x30
	2x4

M12	∅15x12
	2x4

2x

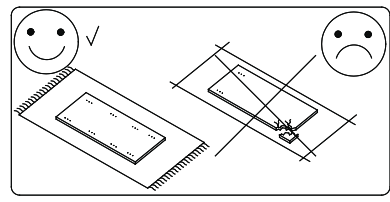
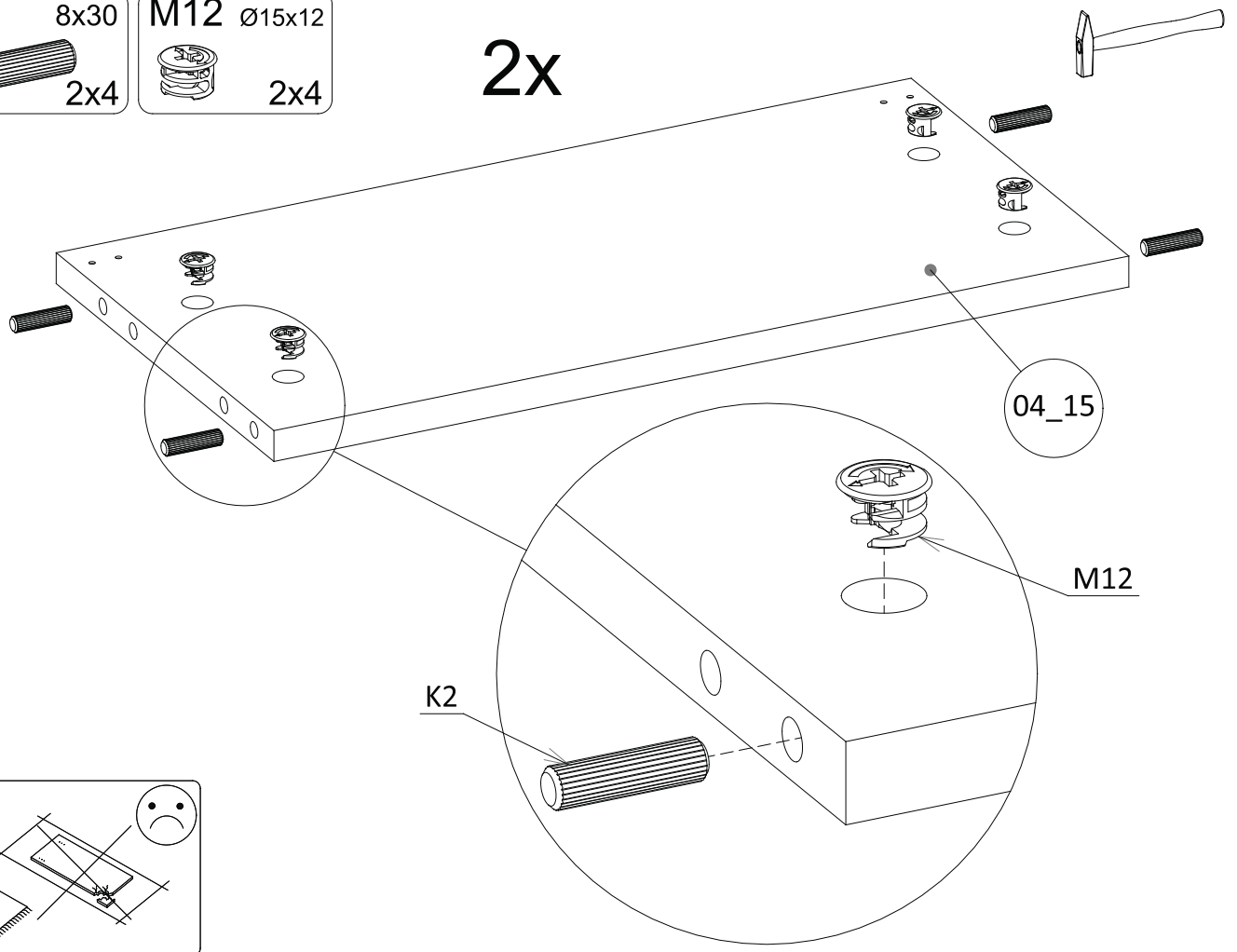

# 46

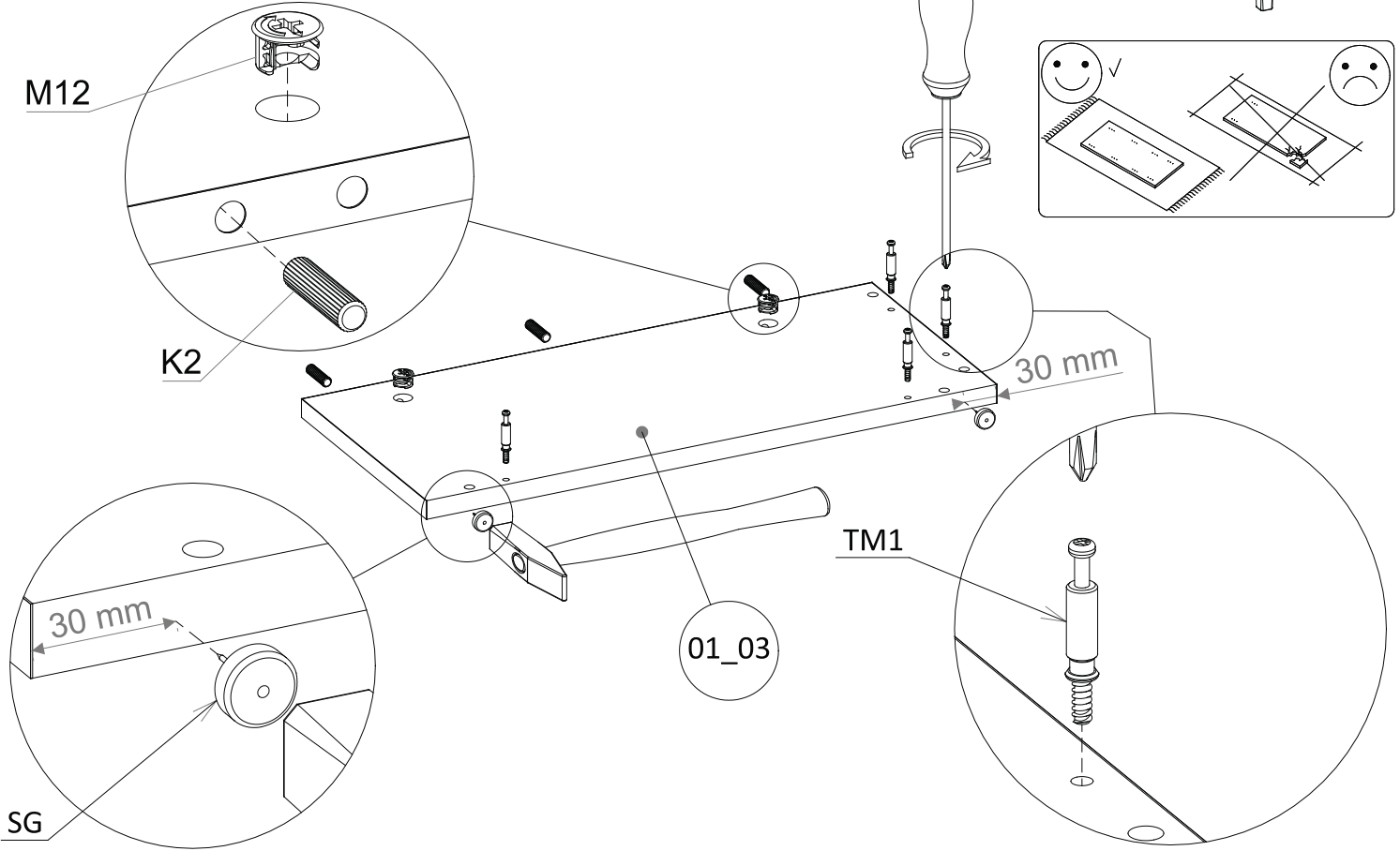
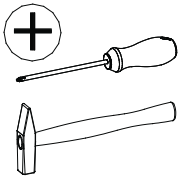
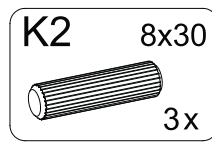
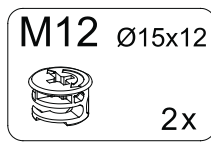
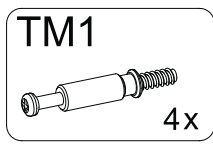
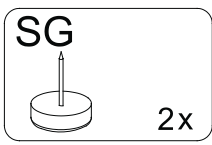

# 47

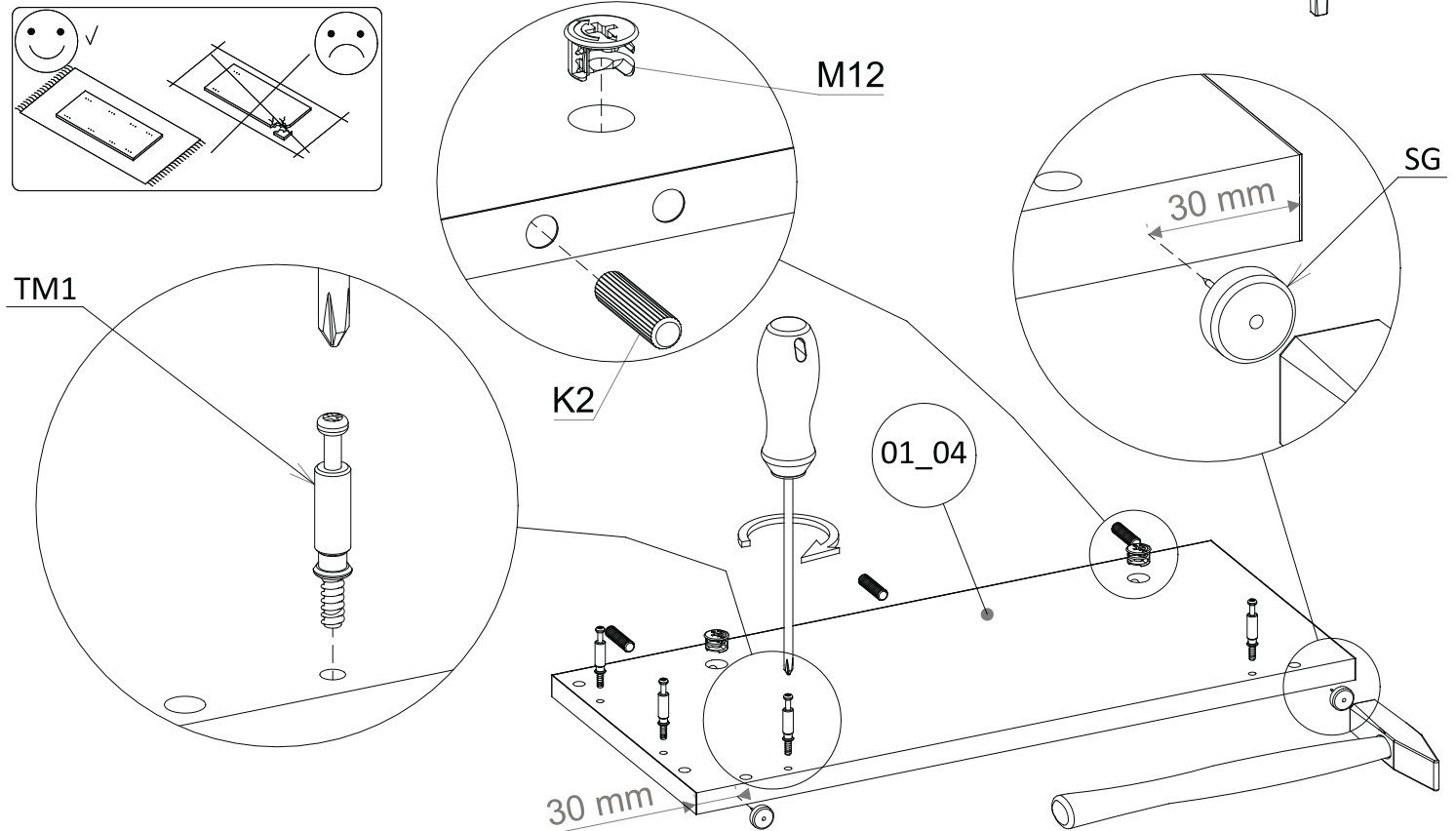
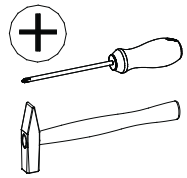
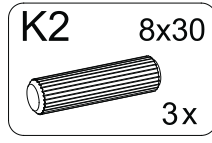
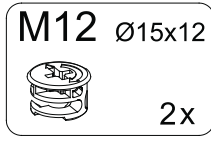
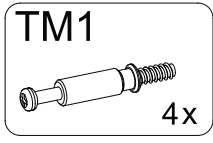
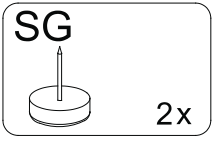

# 48

ZS12  $\varnothing 18$   
K-02  
4x

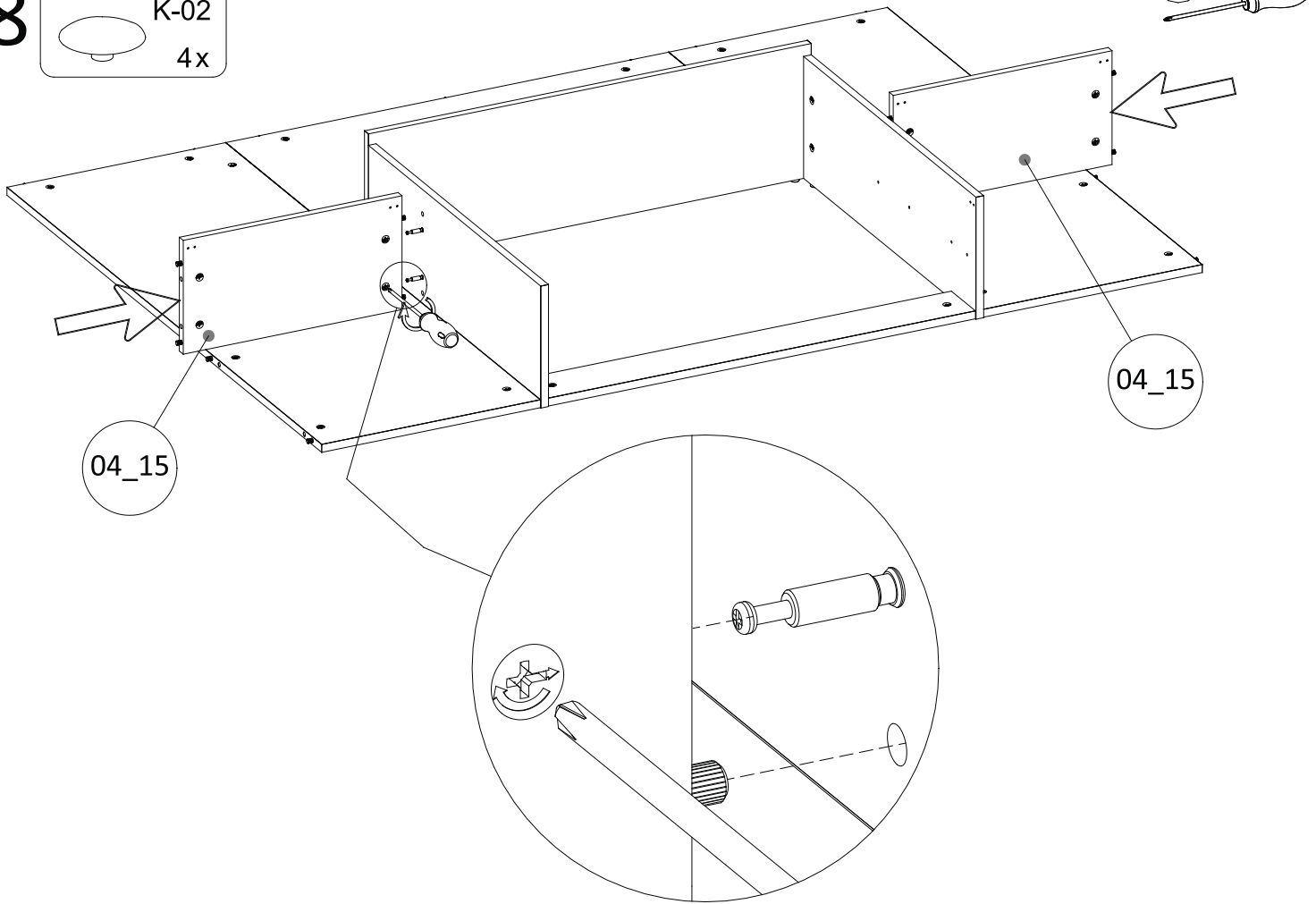

# 49

ZS12  $\varnothing 18$   
K-02  
4x

ZS12  $\varnothing 18$   
K-01  
4x

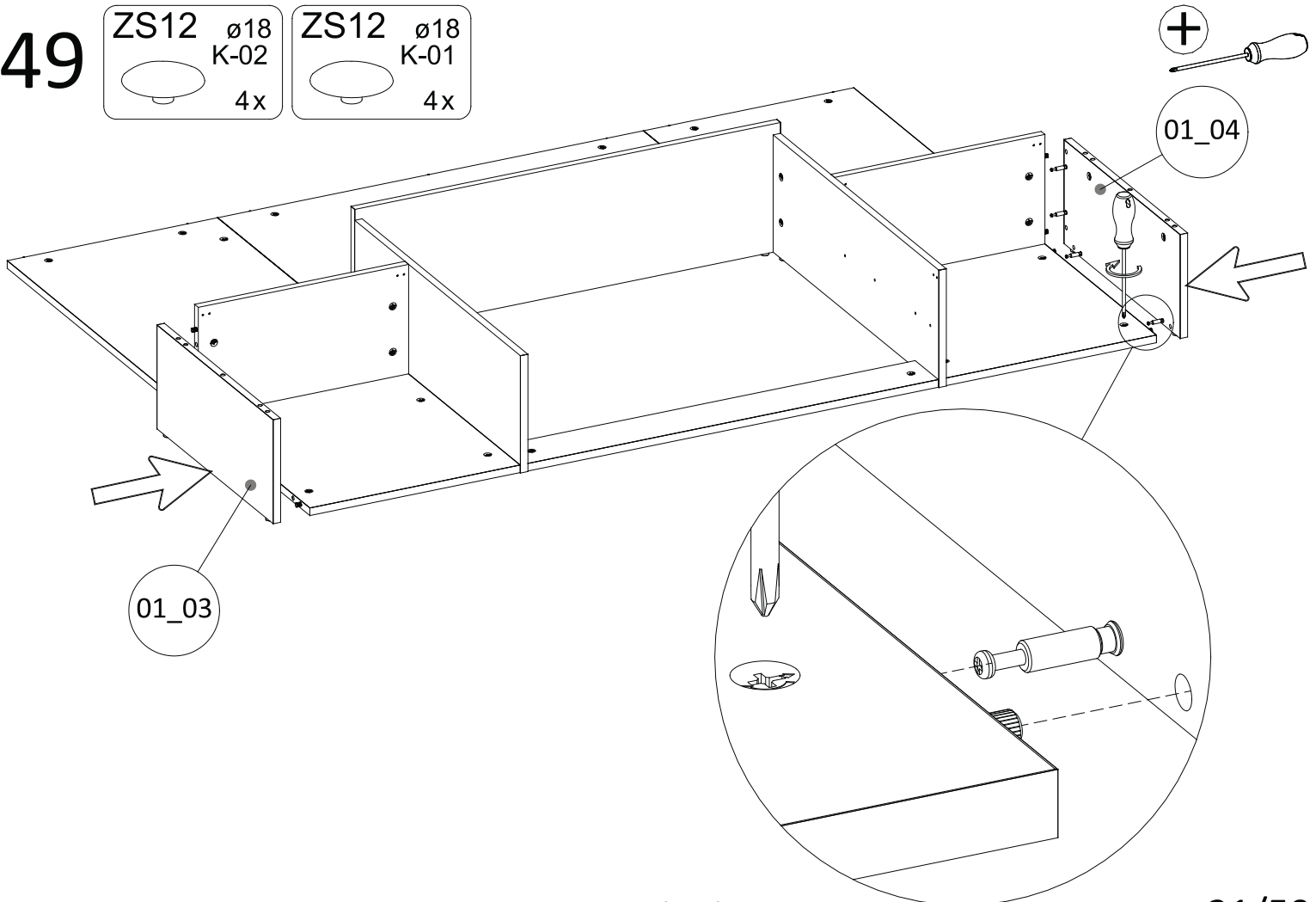

# 50

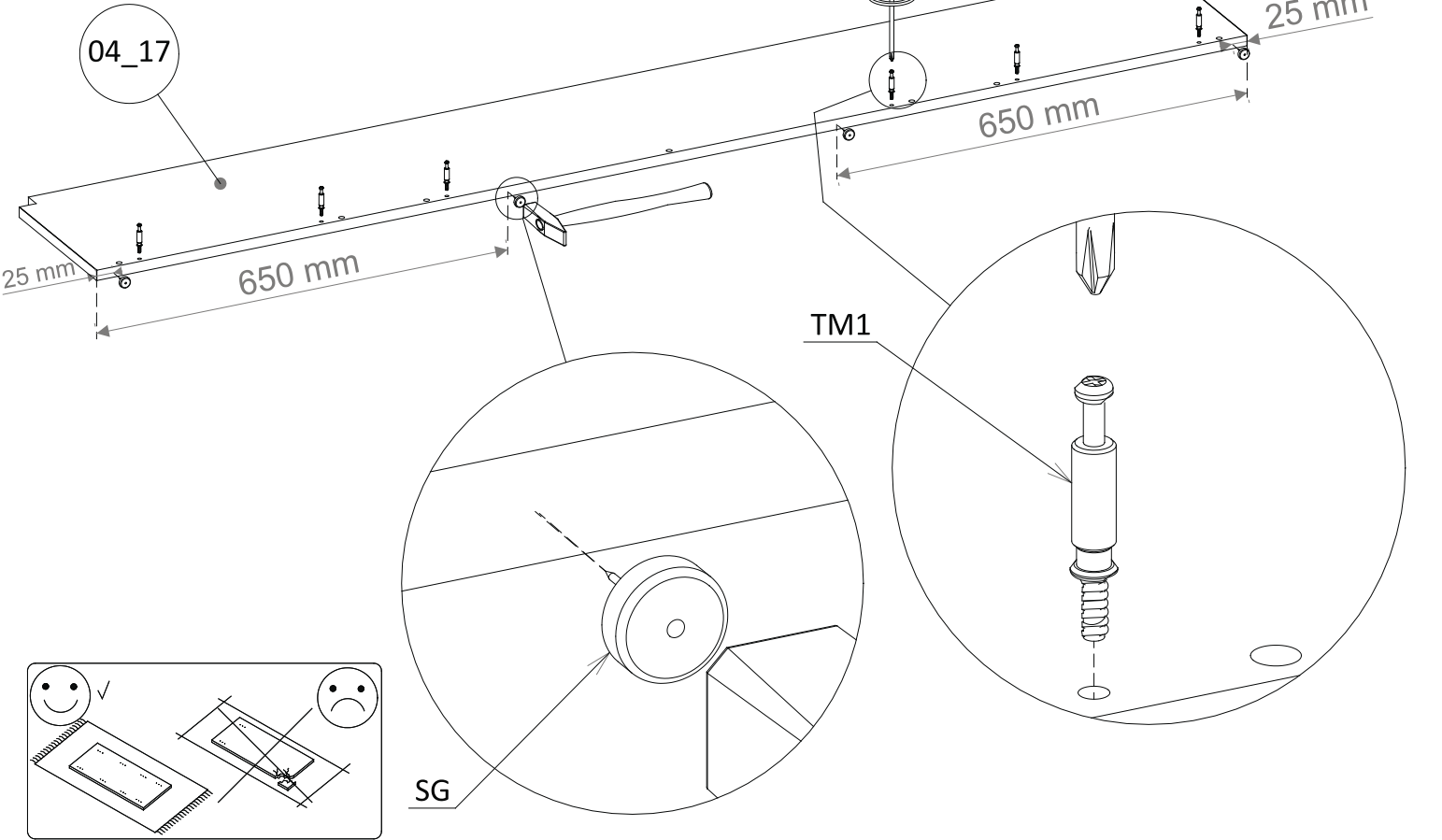
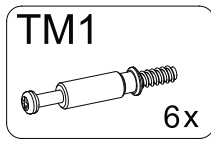
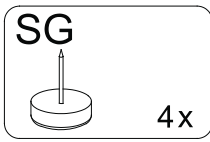

# 51

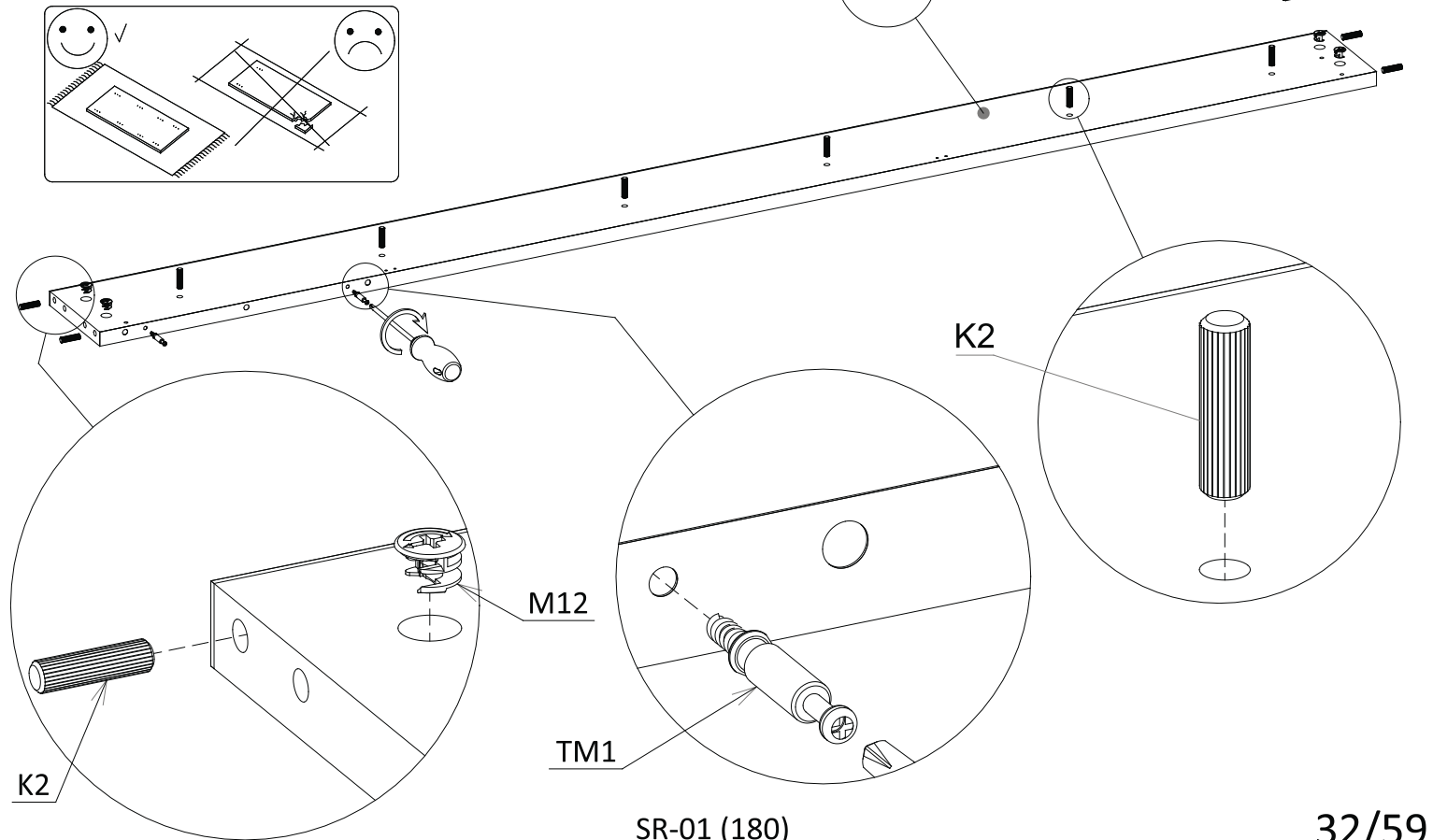
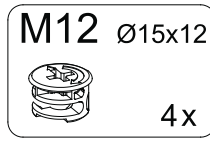
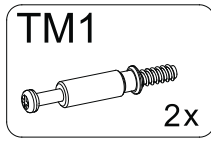
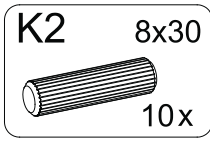

52

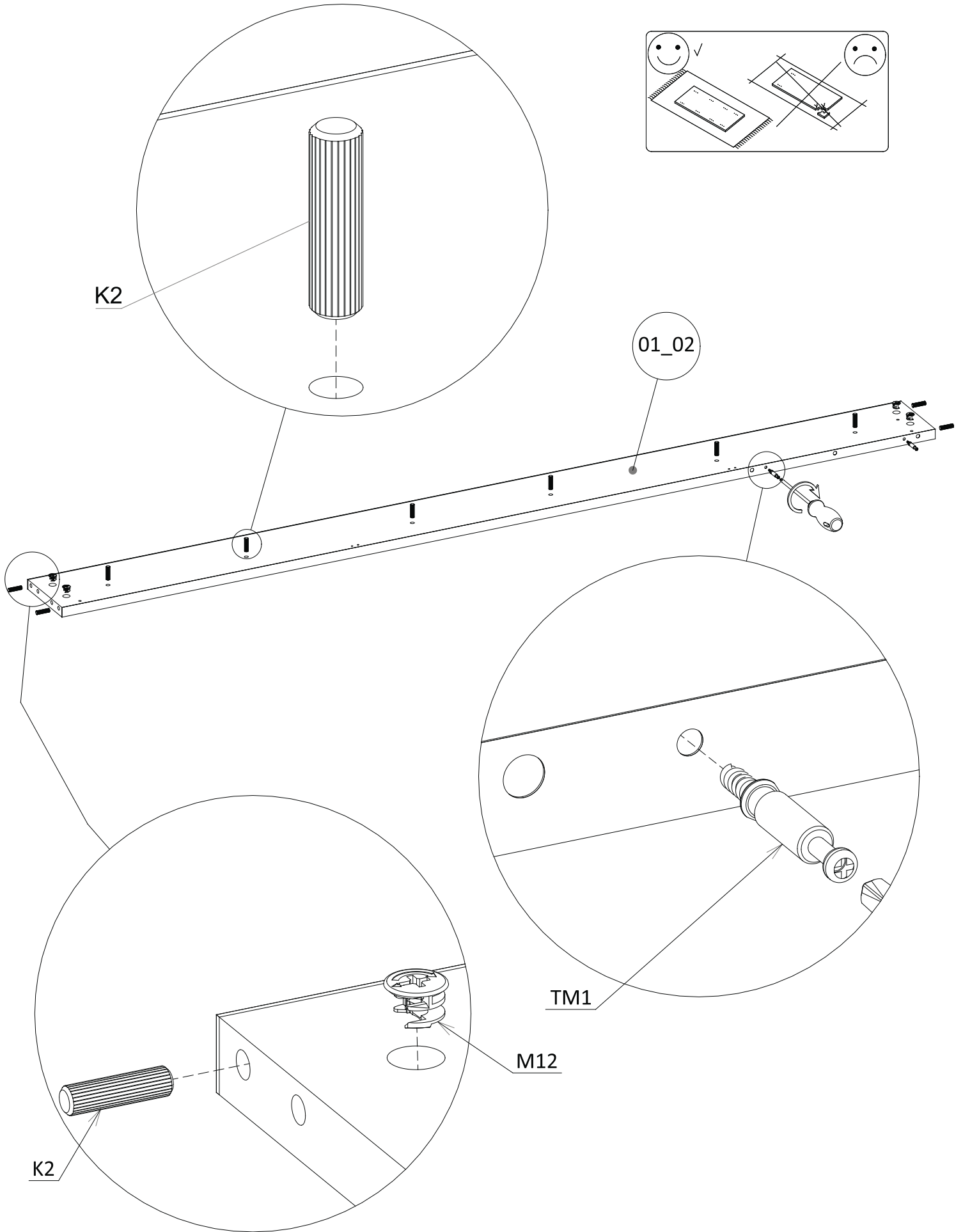
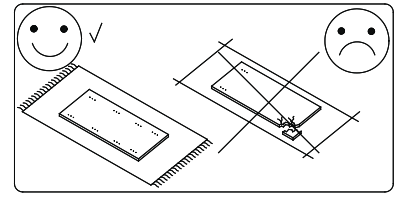
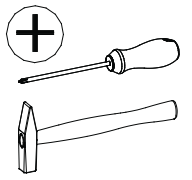
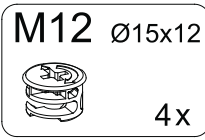
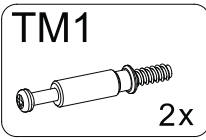
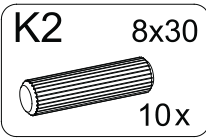

53

W11 4x40  
6x

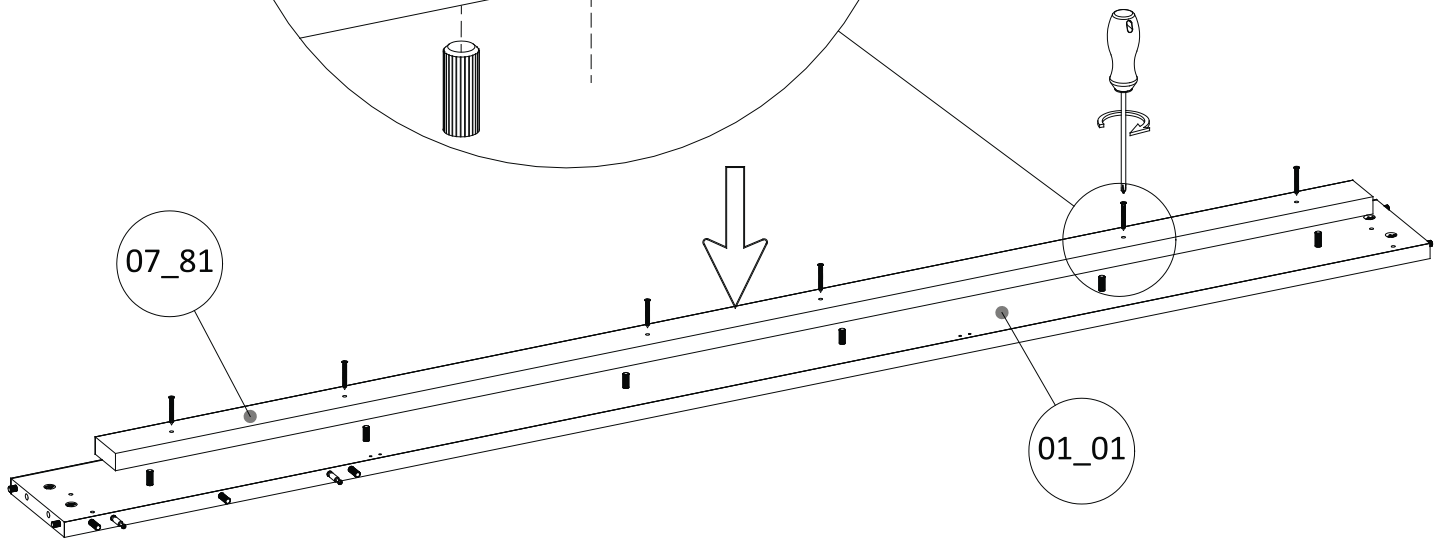
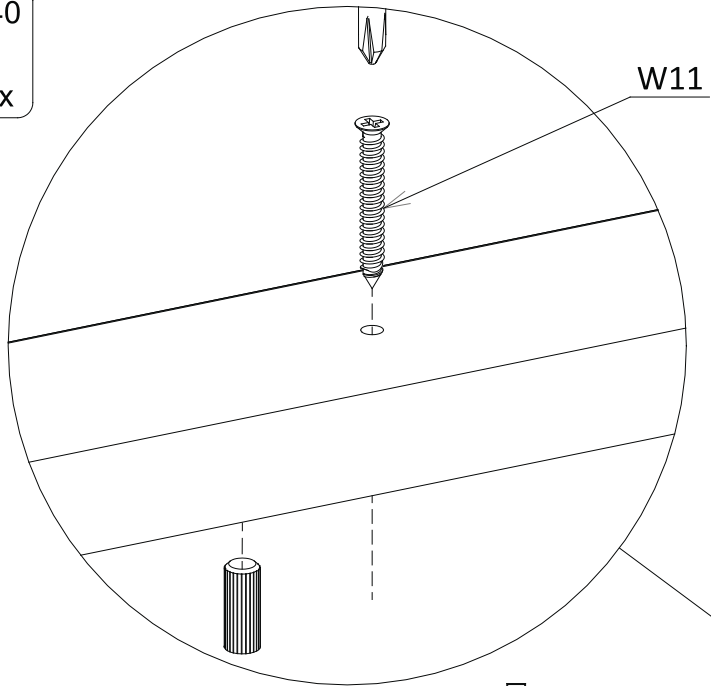
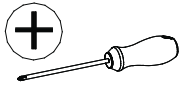

54

W11 4x40  
6x

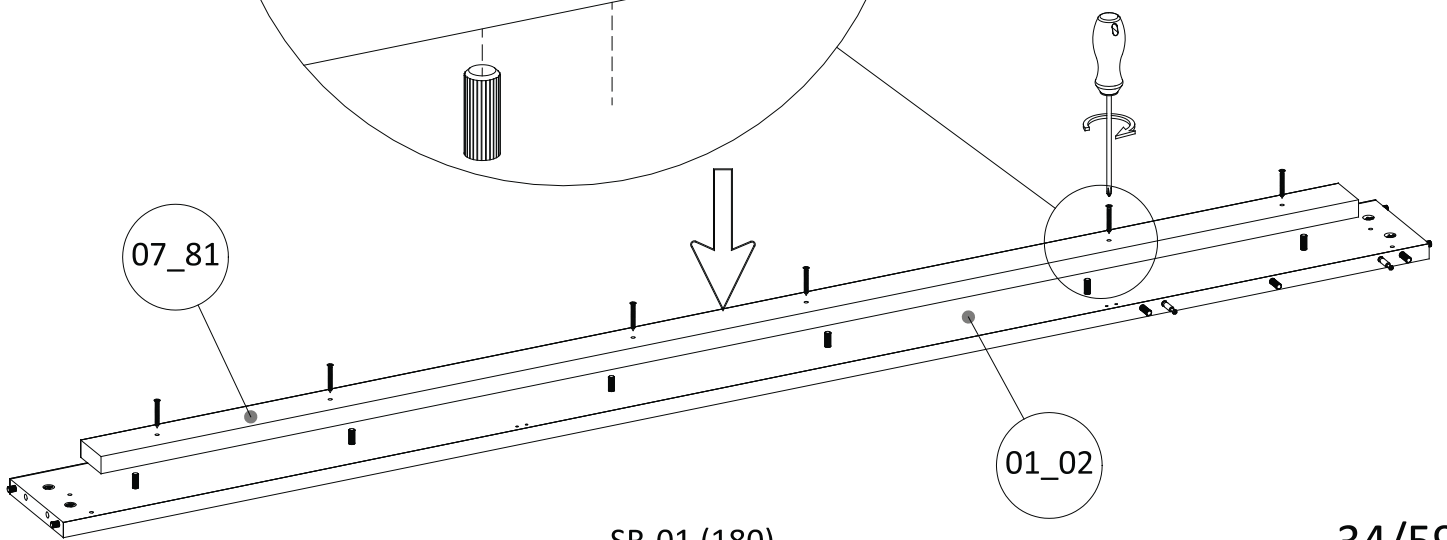
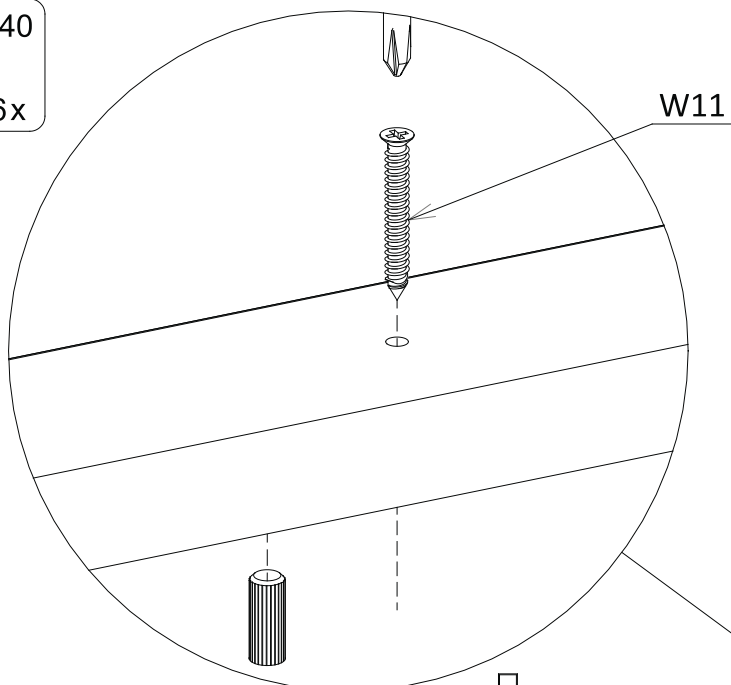
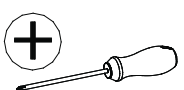

# 55

ZS12  $\varnothing 18$   
K-01  
6x

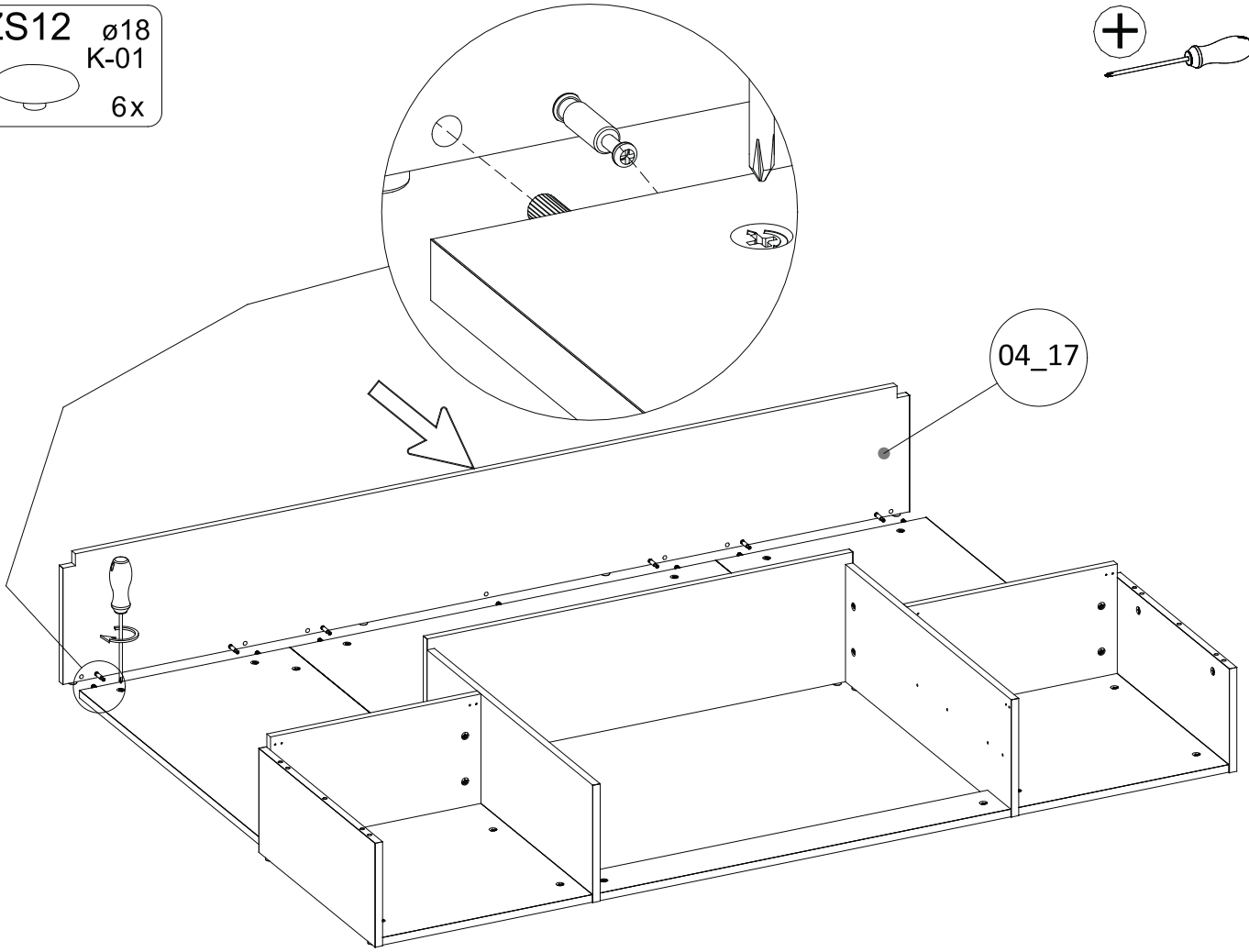
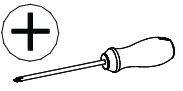

# 56

ZS12  $\varnothing 18$   
K-01  
2x

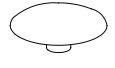

W6 3,5x16  
8x



KU31 31x31  
2x

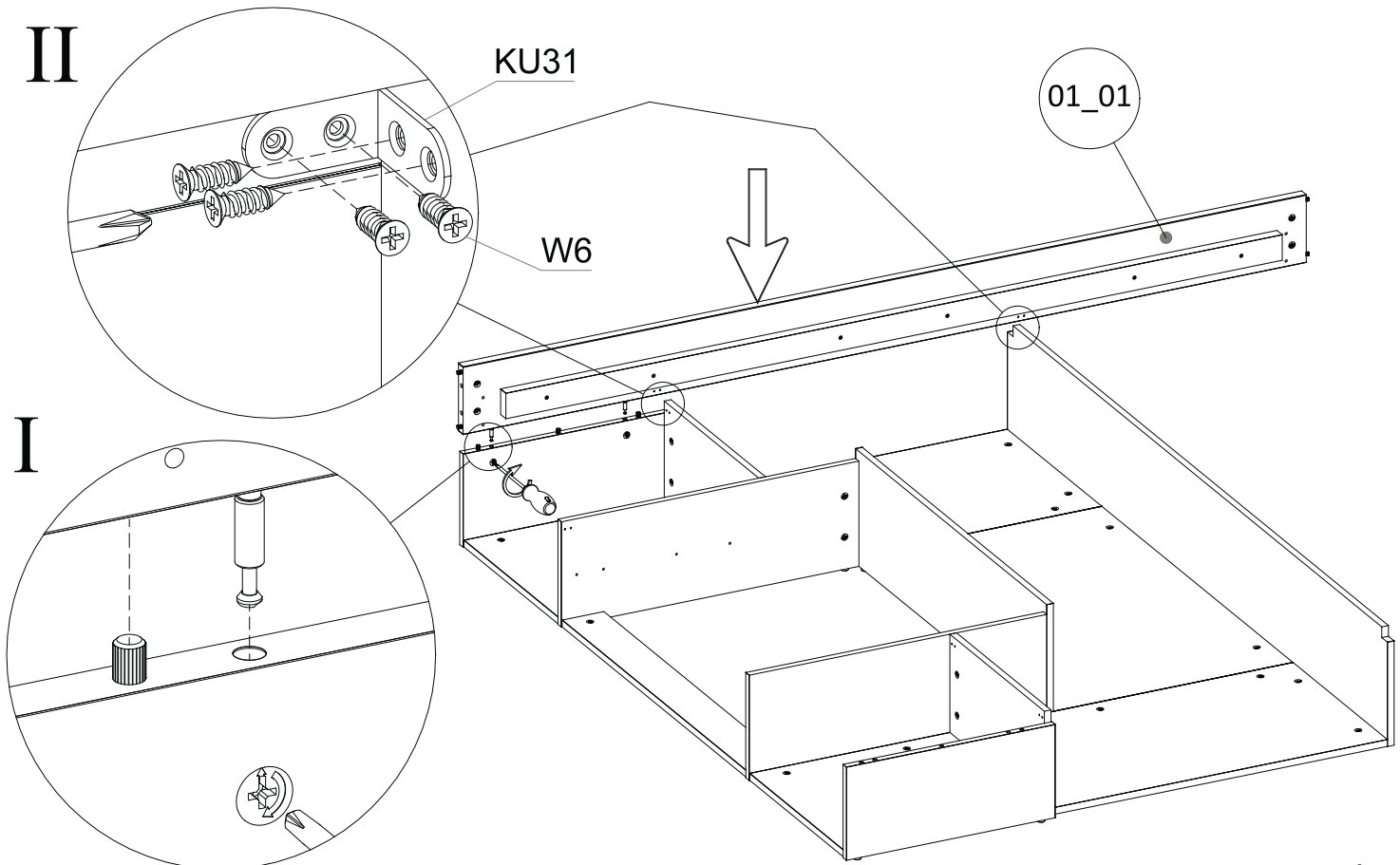
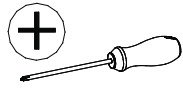
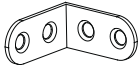

# 57

ZS12  $\varnothing 18$   
K-01  
2x

W6 3,5x16  
8x

KU31 31x31  
2x

# II

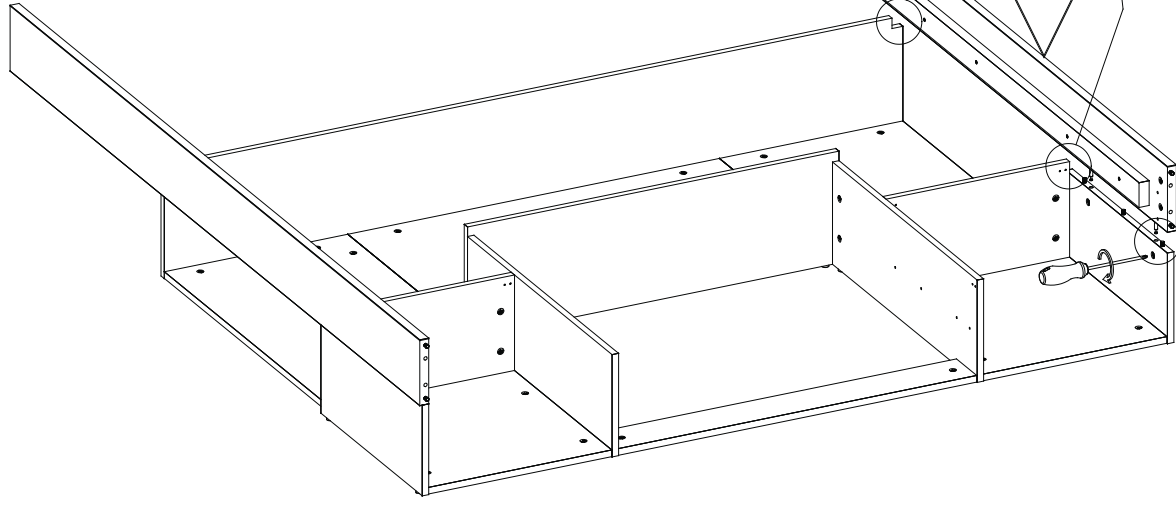
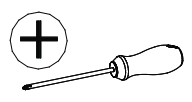

01\_02

KU31

W6

# I

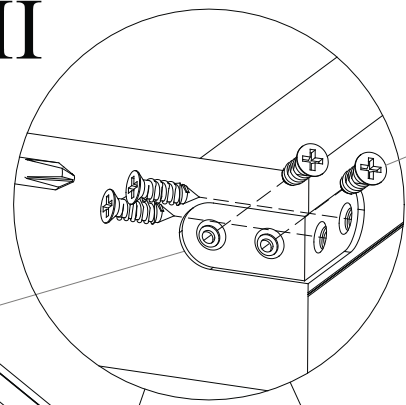
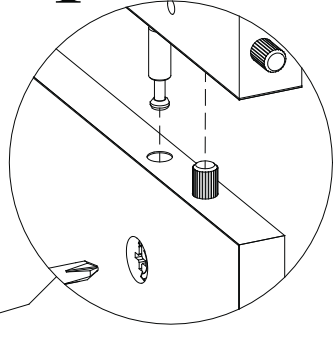

# 58

TM1  
4x

ZL  
1x

W6 3,5x16  
4x

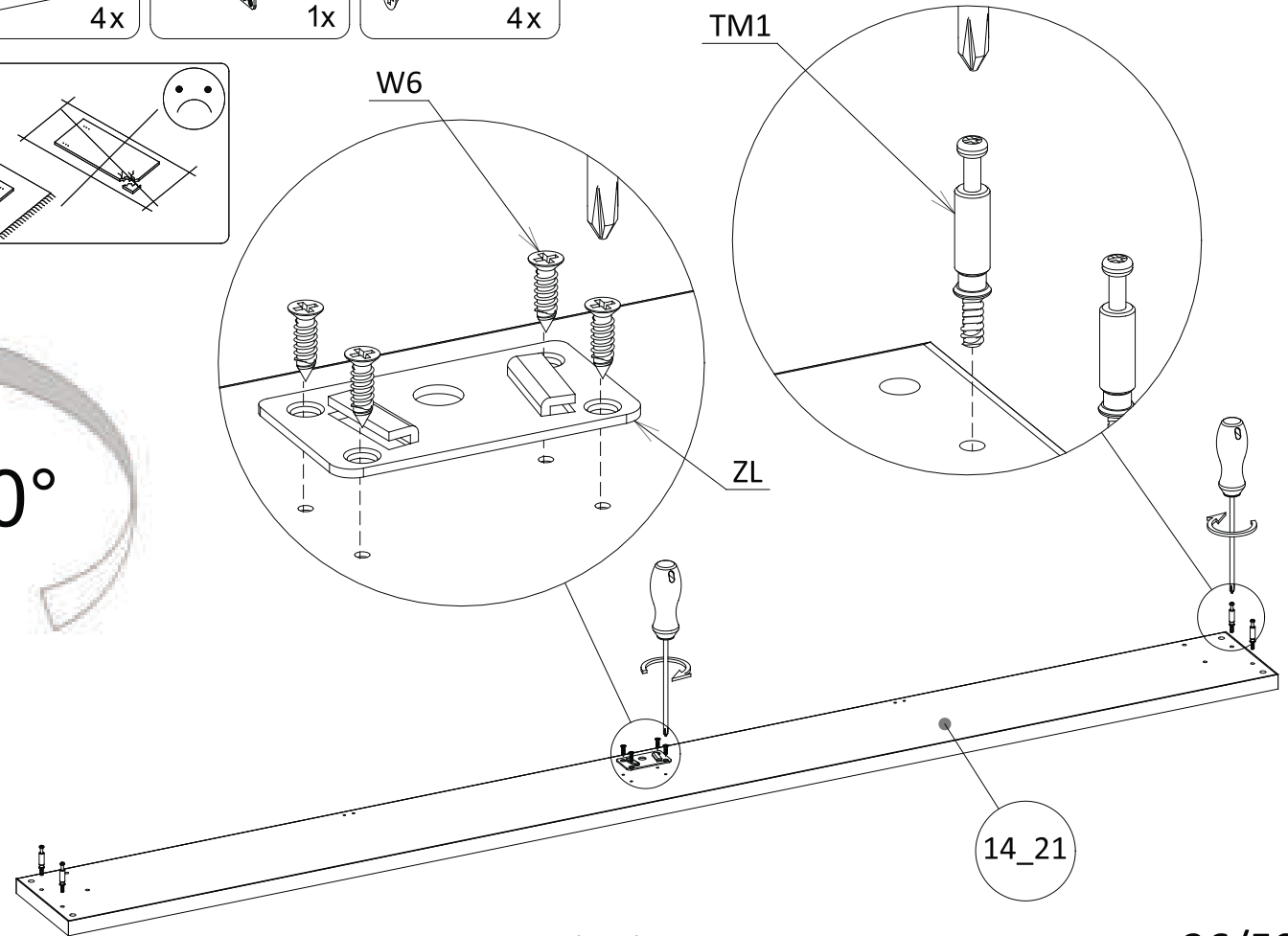
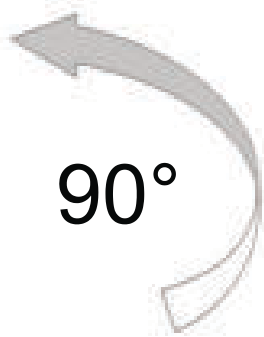
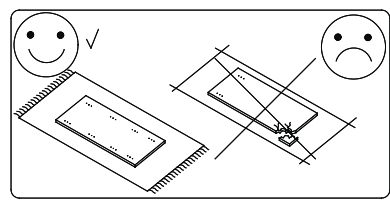
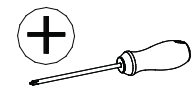

TM1

W6

ZL

14\_21

59

ZS12  $\varnothing 18$   
K-01  
2x

KU31 31x31  
2x

W6 3,5x16  
8x

II

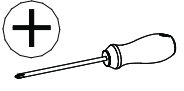

14\_21

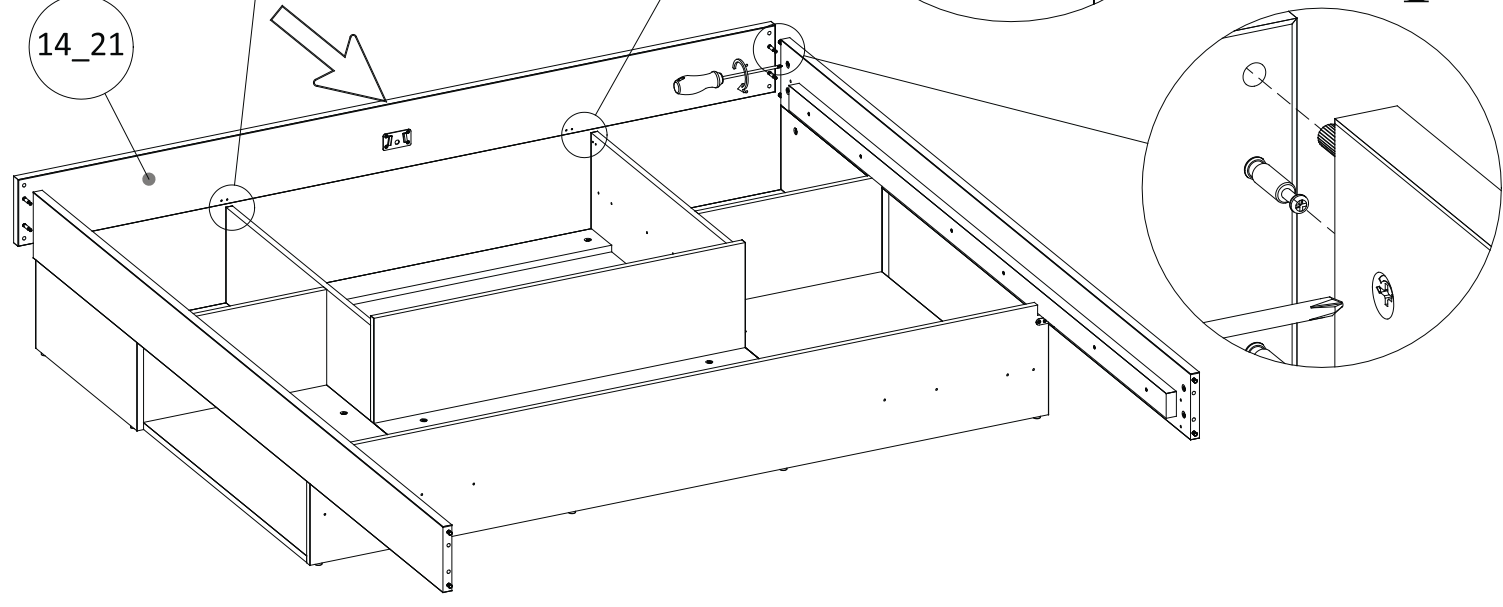

I

60

ZS12  $\varnothing 18$   
K-01  
2x

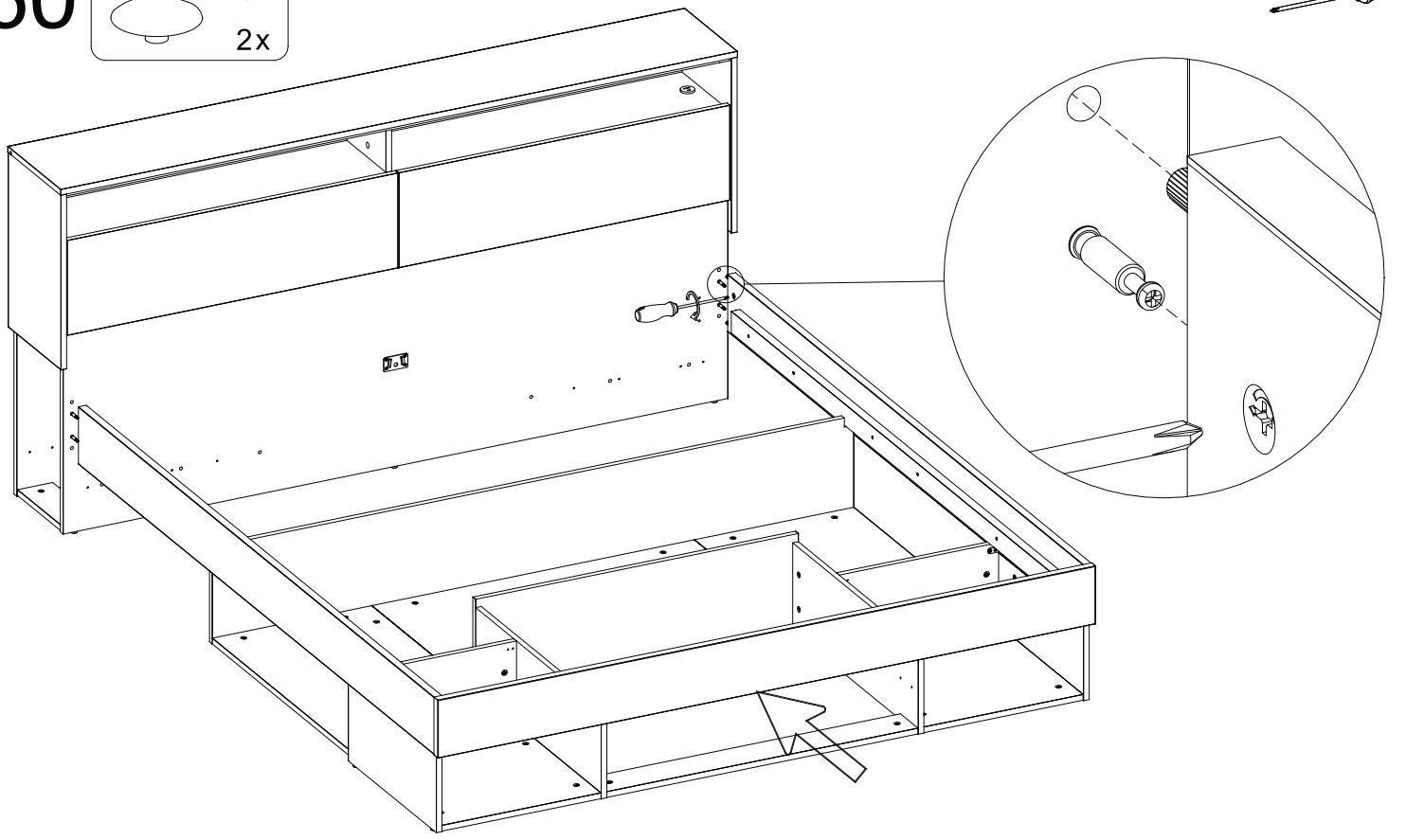
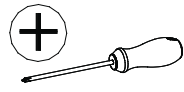

# 61

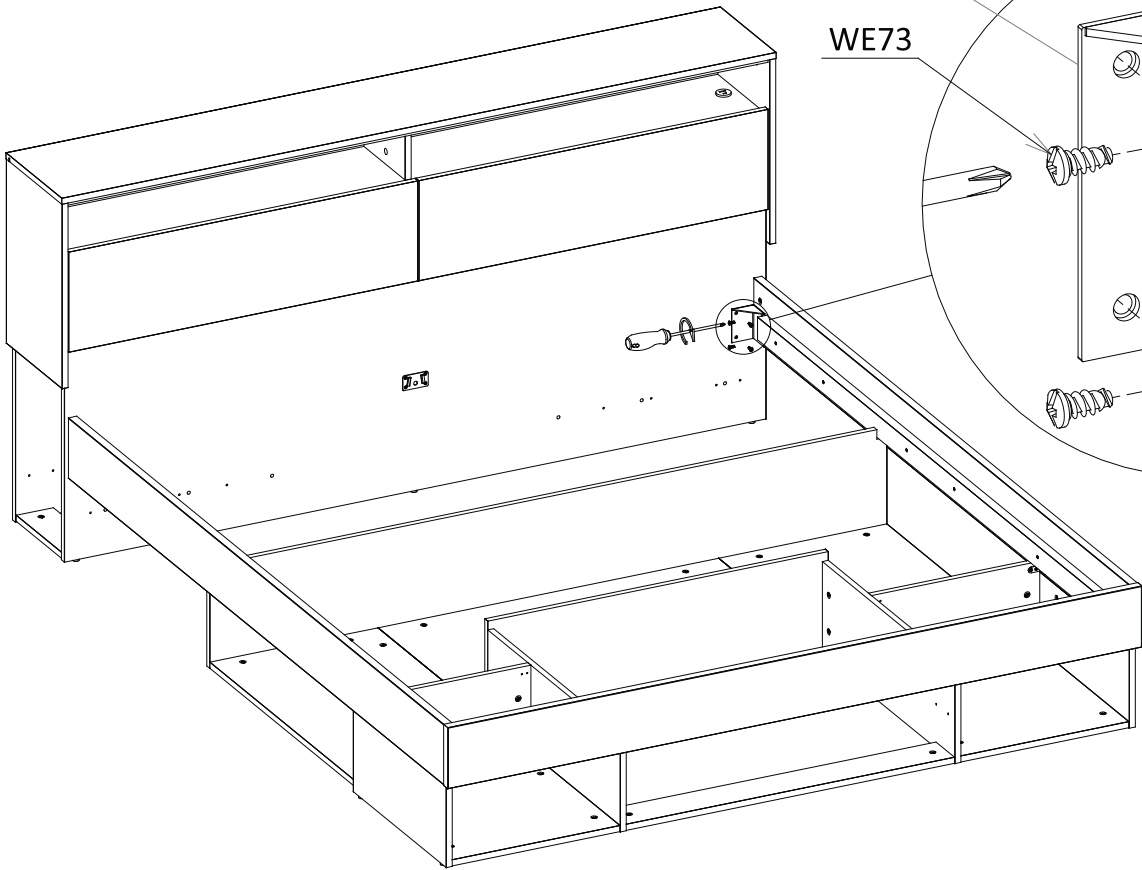
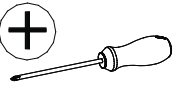
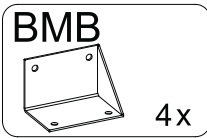

# 62

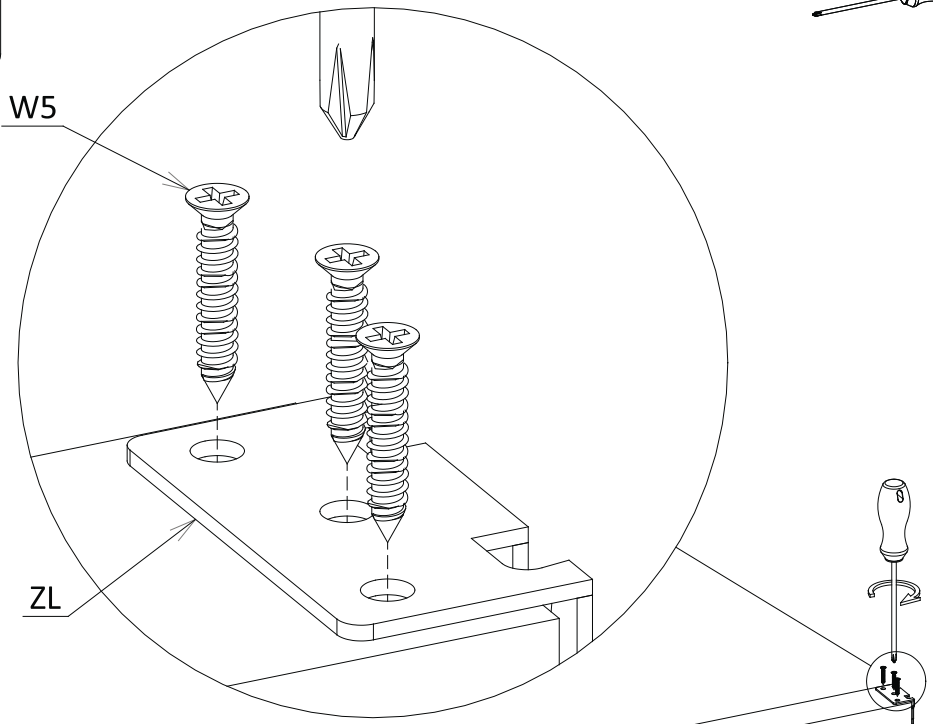
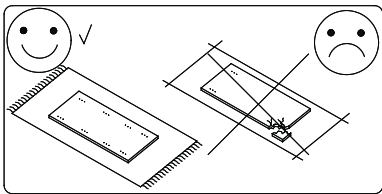
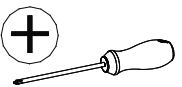
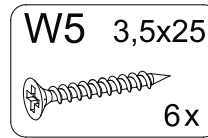
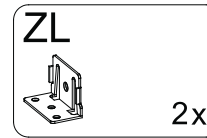

07\_16

63

K3 8x20  
2x3

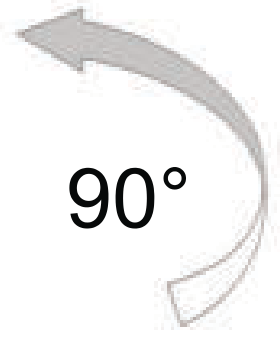
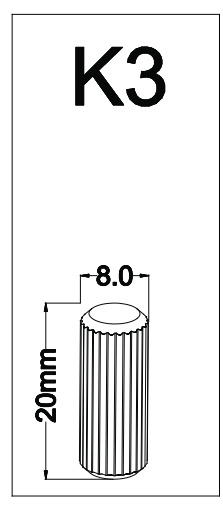
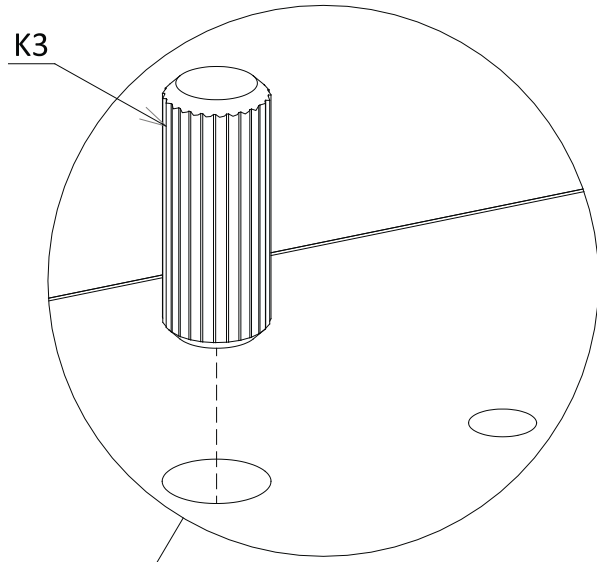
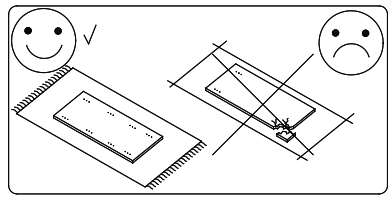

90°

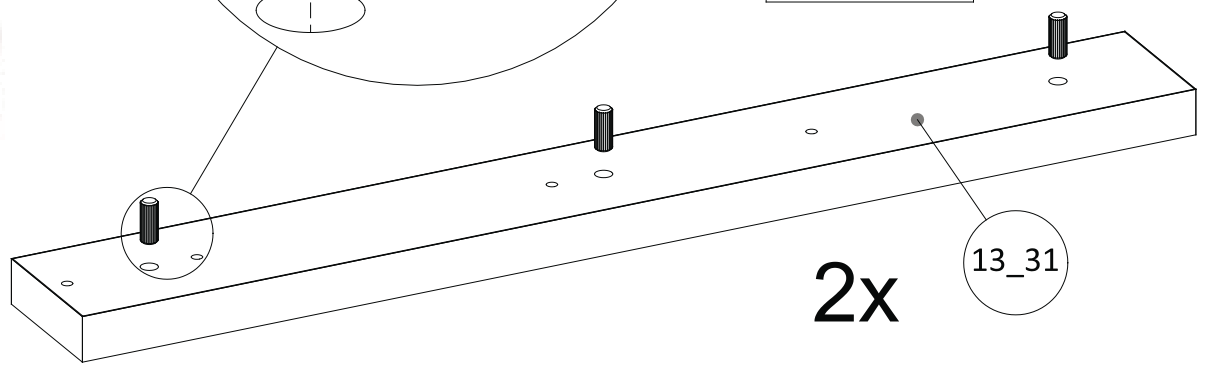

64

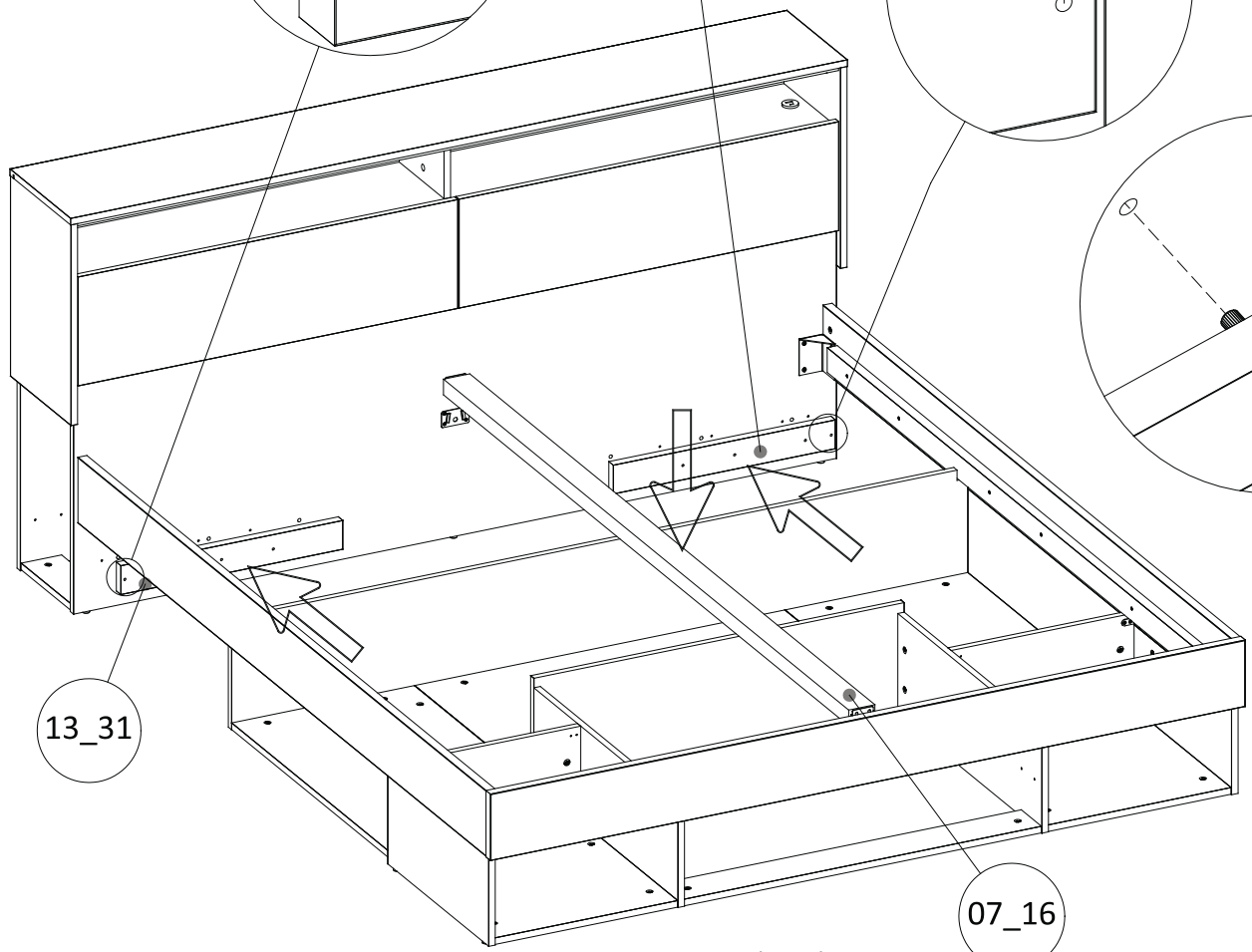
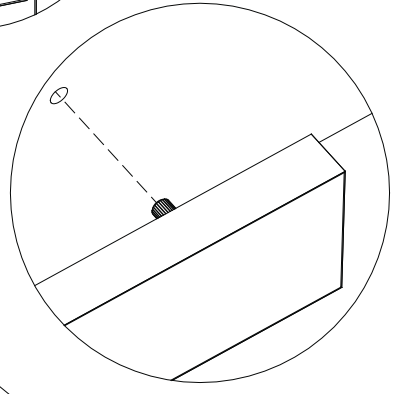
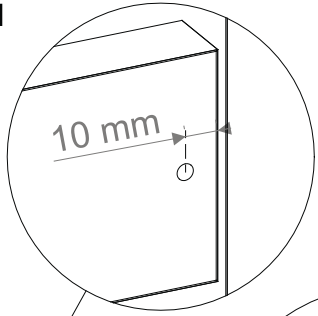
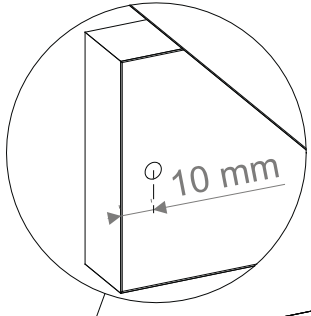

I

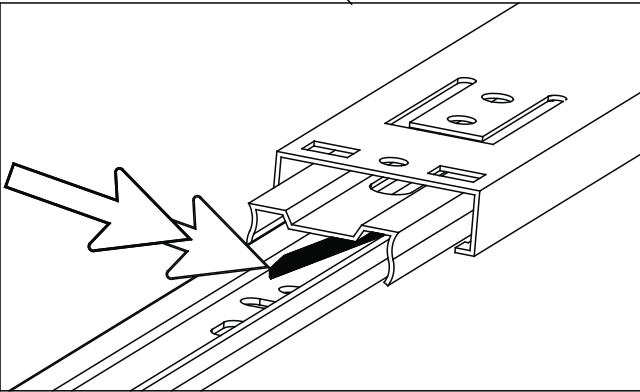
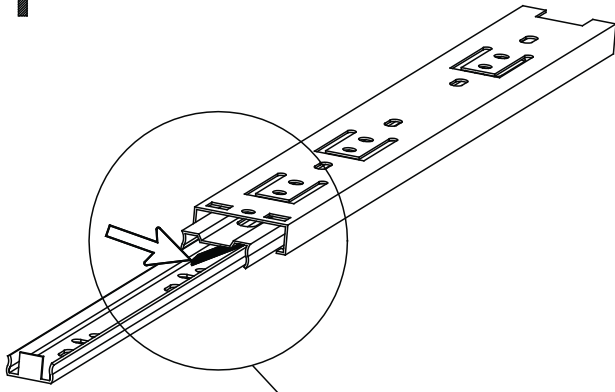

II

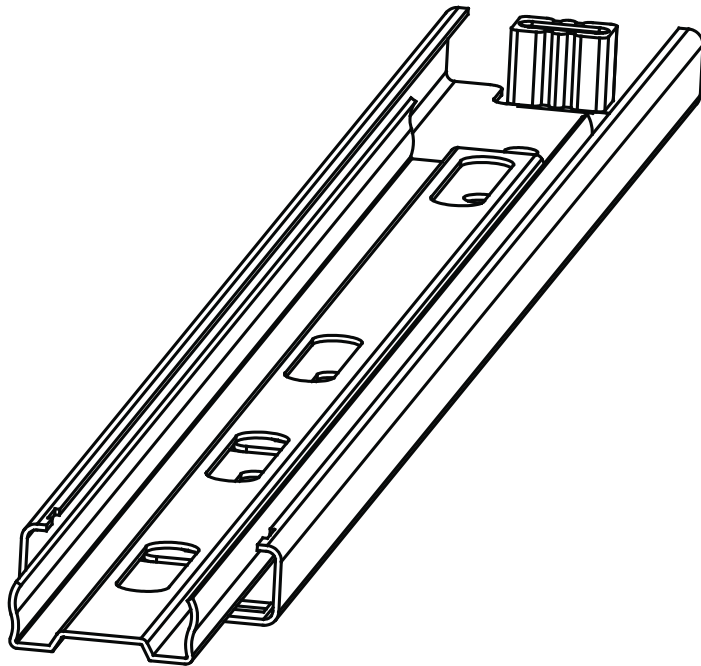
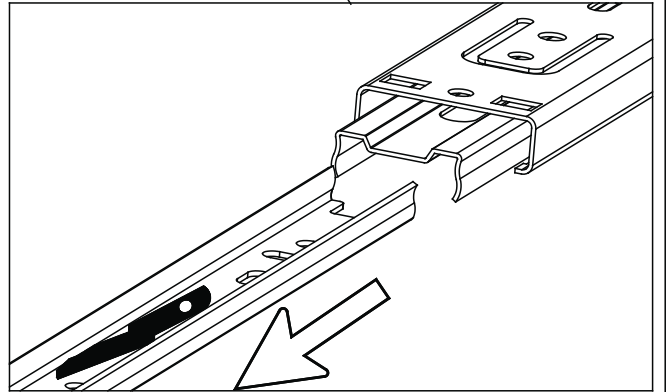
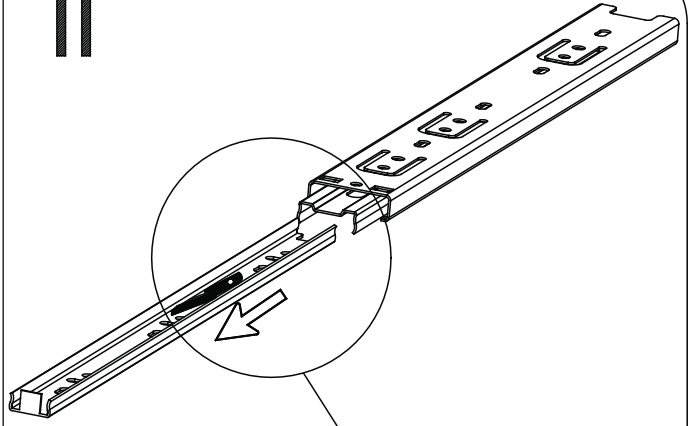

# 65

WE61 5x13  
8x

PQ64 L=450  
H=35  
2x

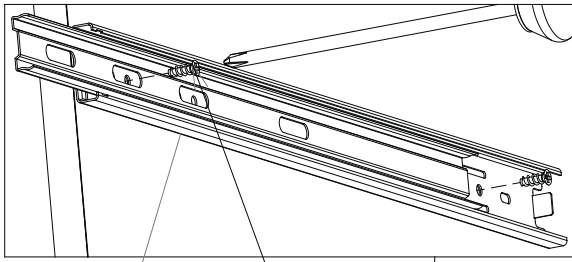
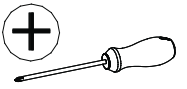

PQ64

WE61

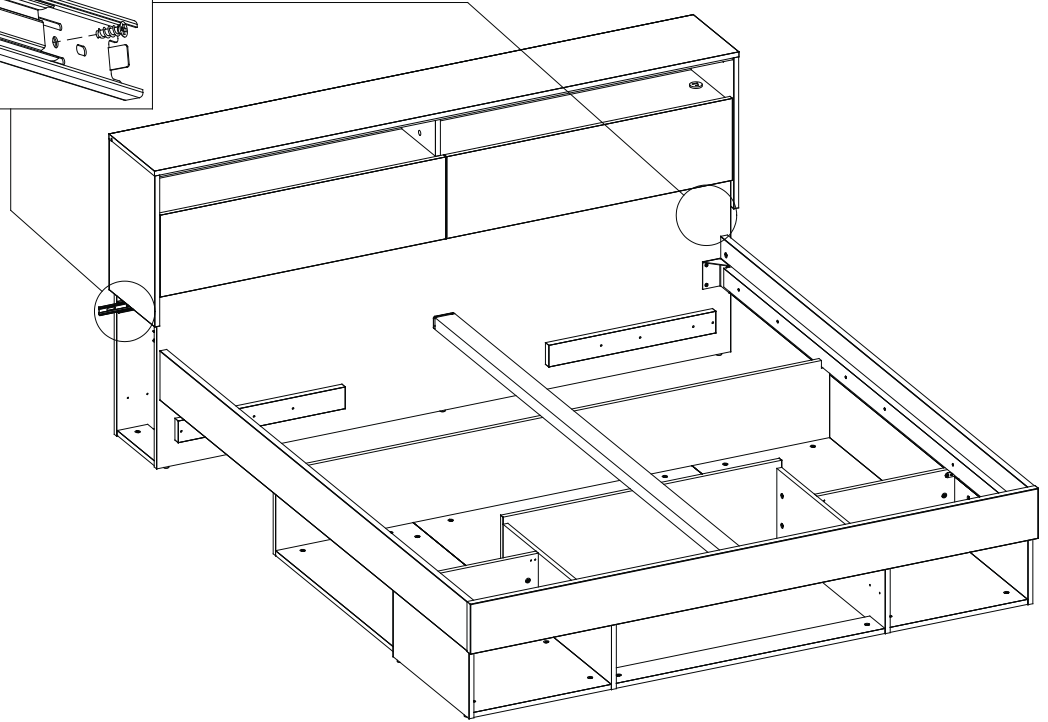

# 66

WE61 5x13  
24x

PQ71 L=500  
H=45  
3x

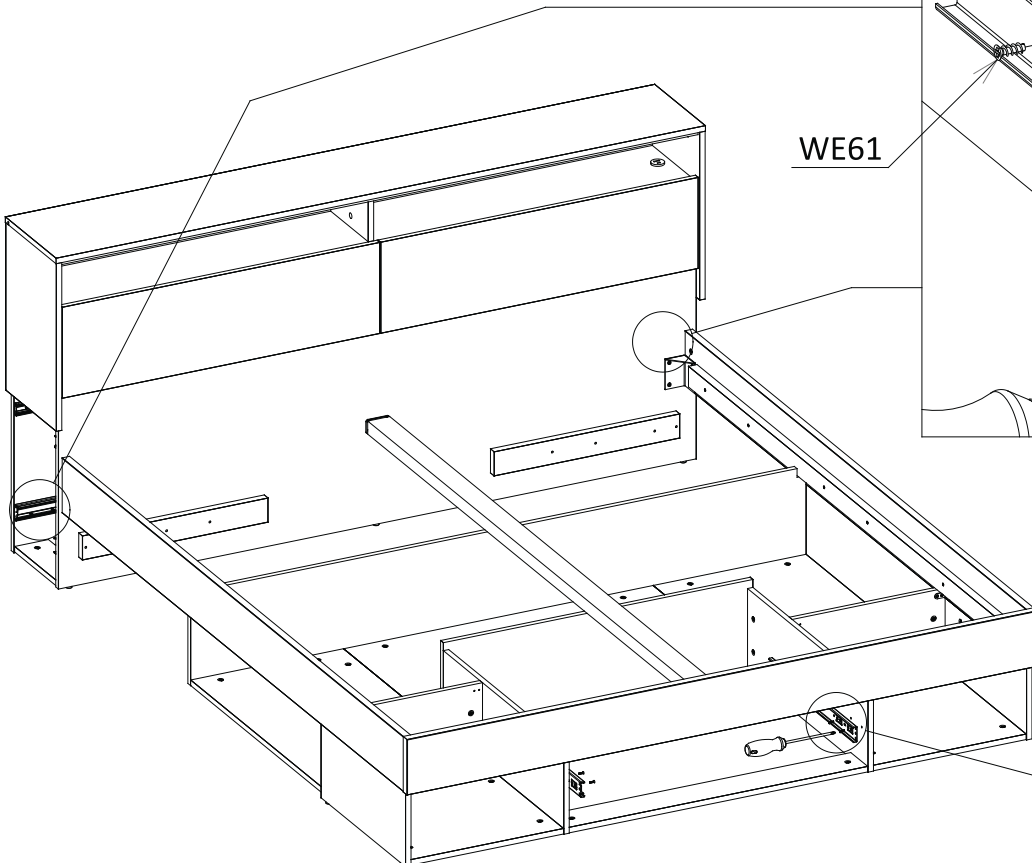
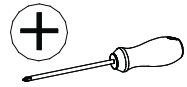

PQ71

WE61

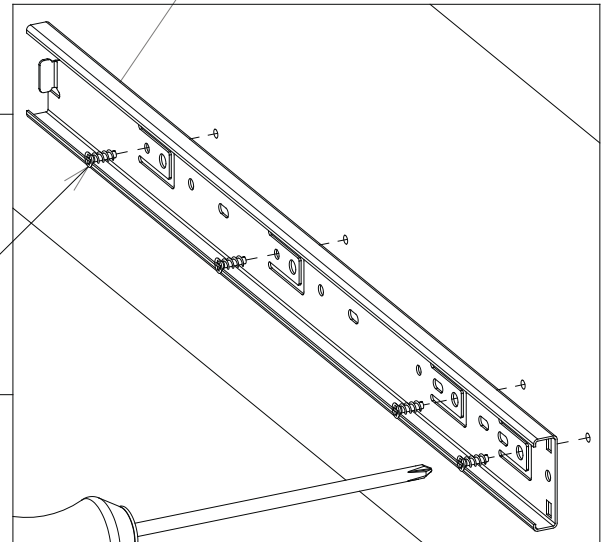

67

WE61 5x13  
8x

PQ71 L=500  
H=45  
2x

WE65 5x32  
8x

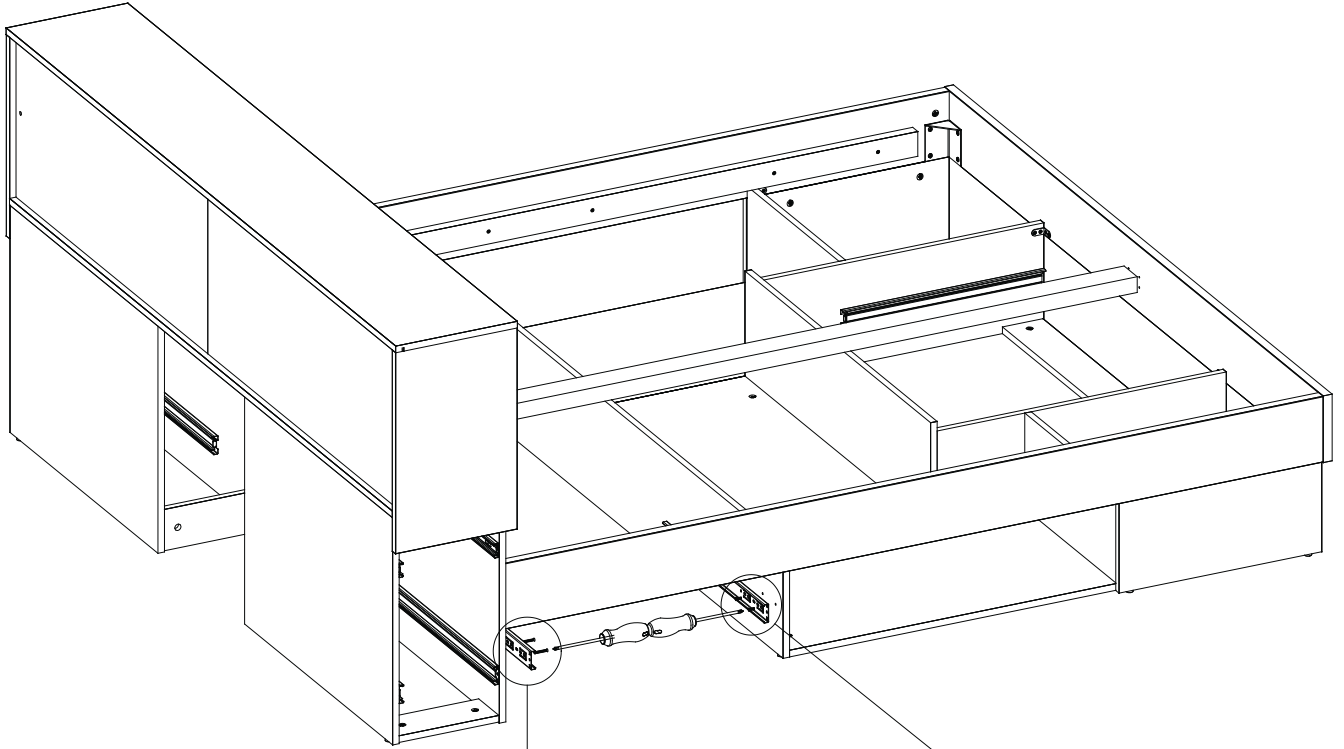
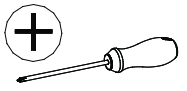

WE65

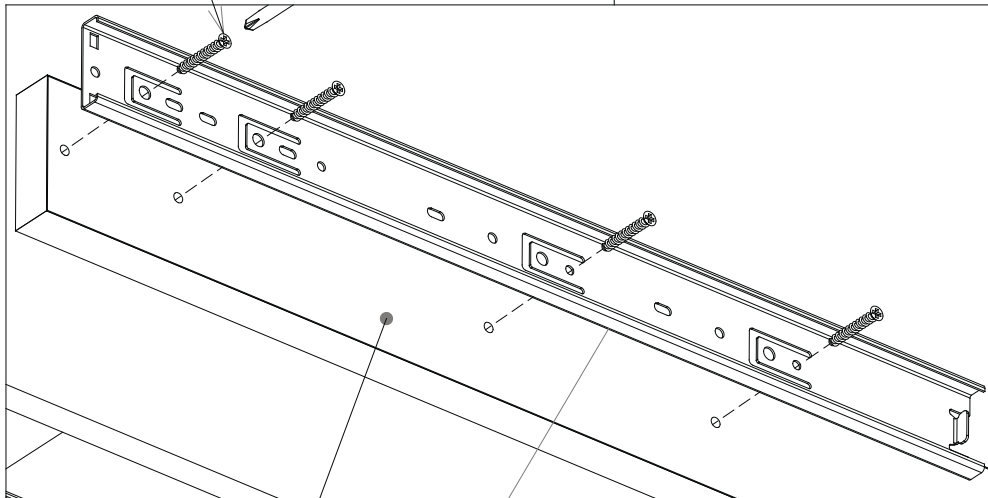

PQ71

13\_31

PQ71

WE61

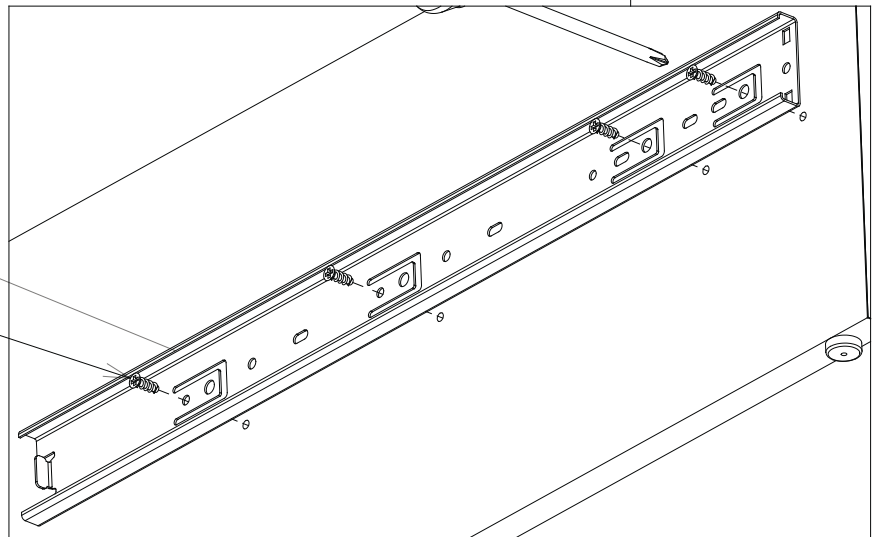

68

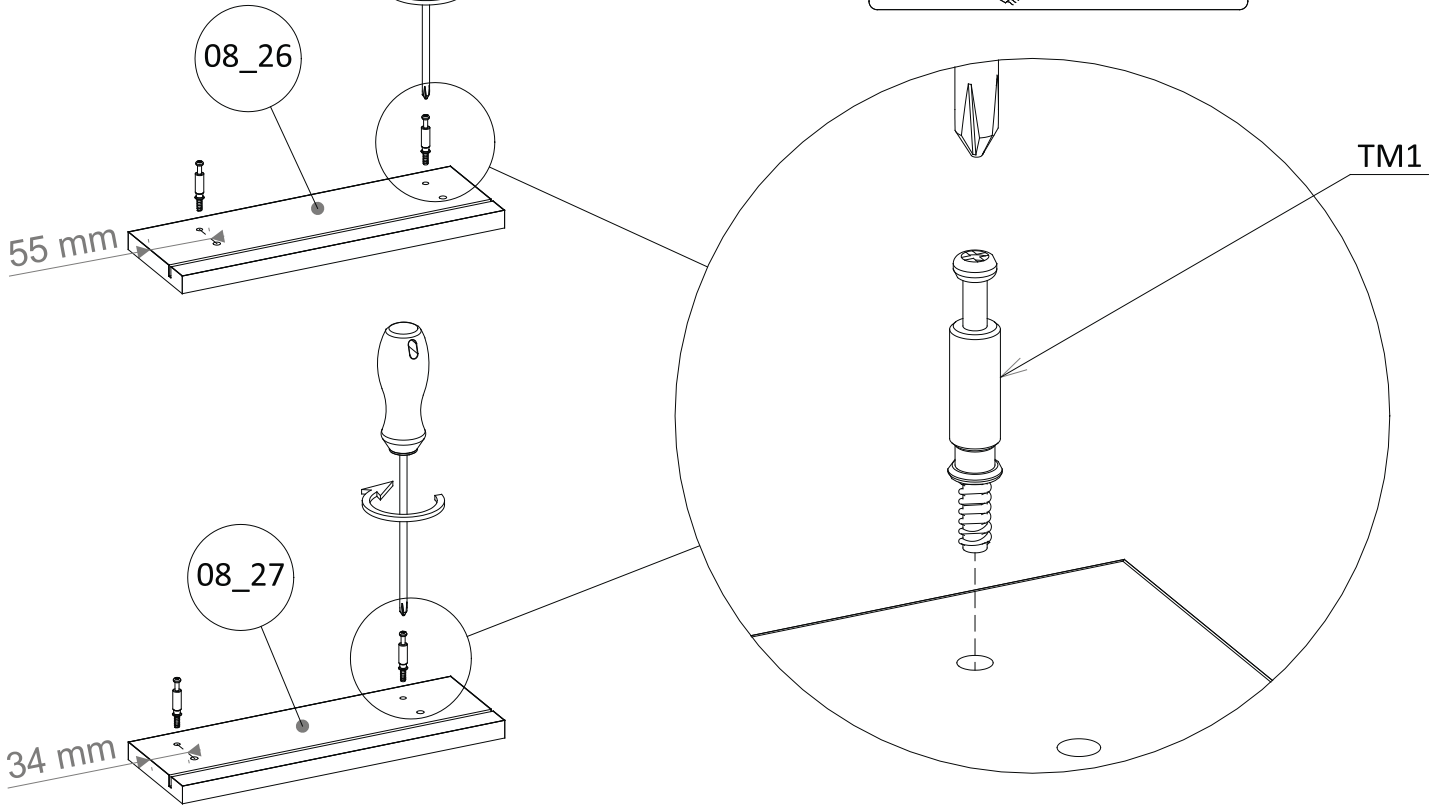
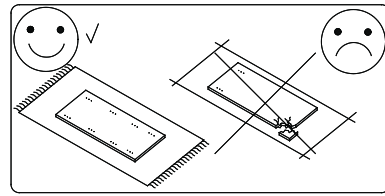
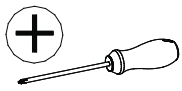
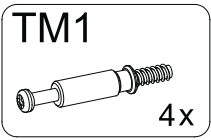

69

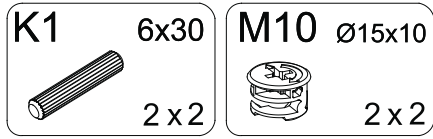

2x

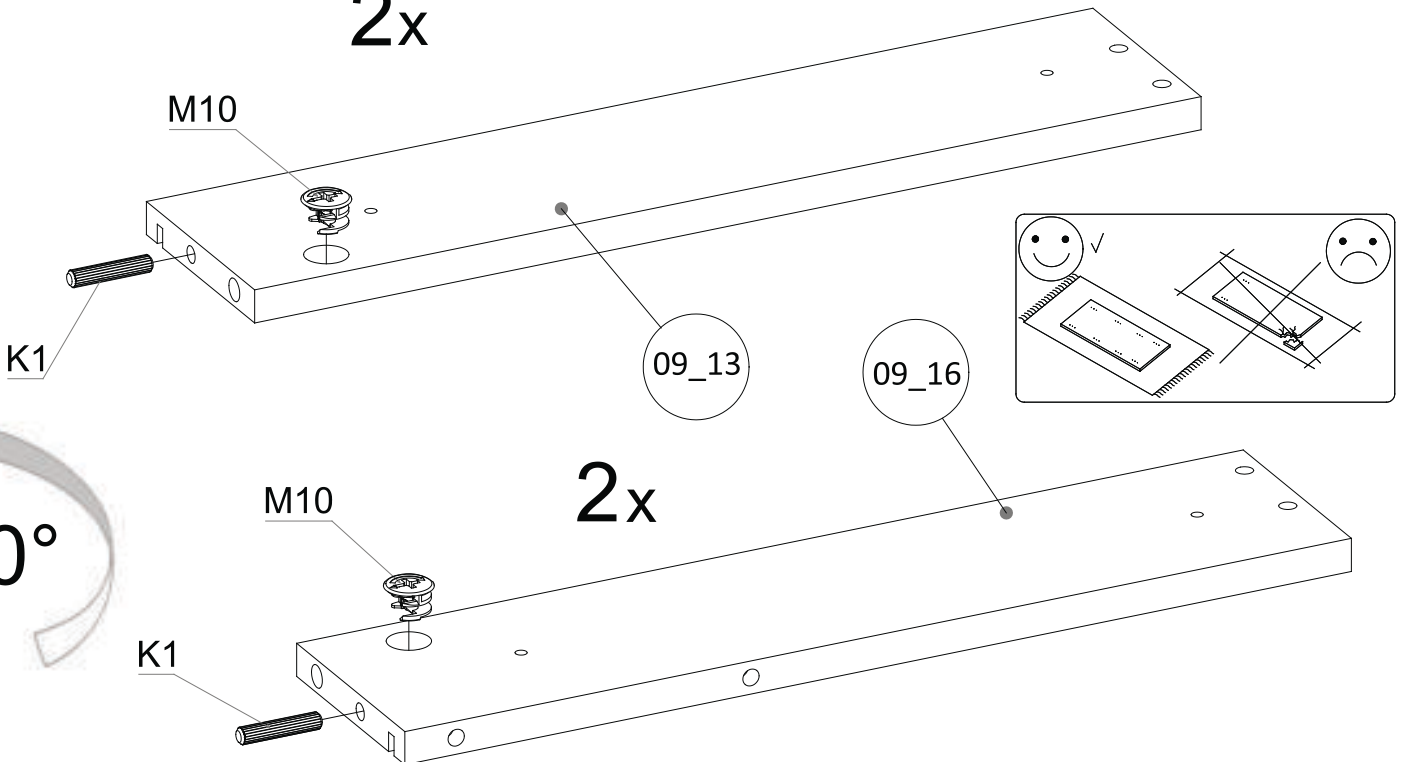

70

KN1 7x40  
4x2

KL4  
4 mm

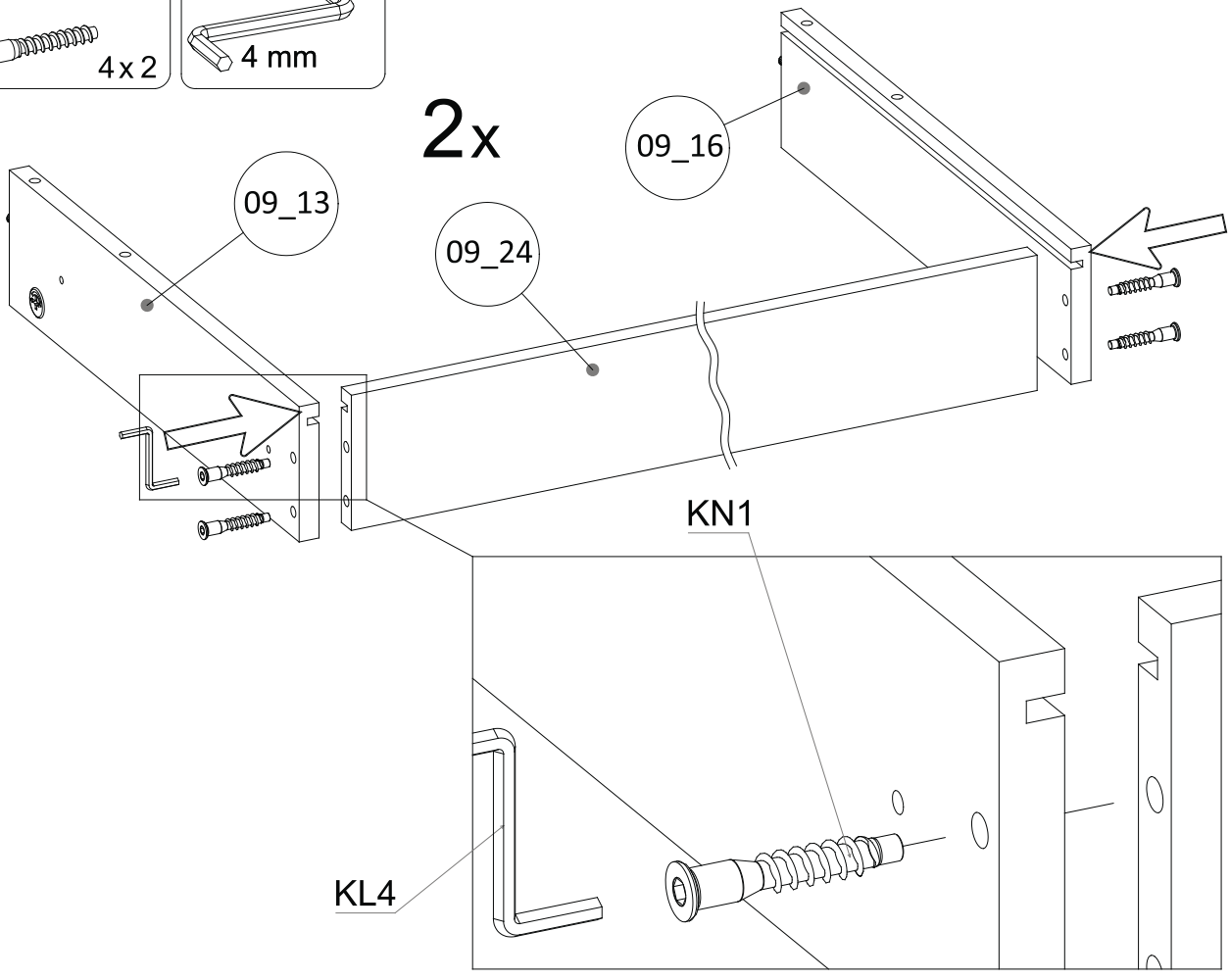

71

2x

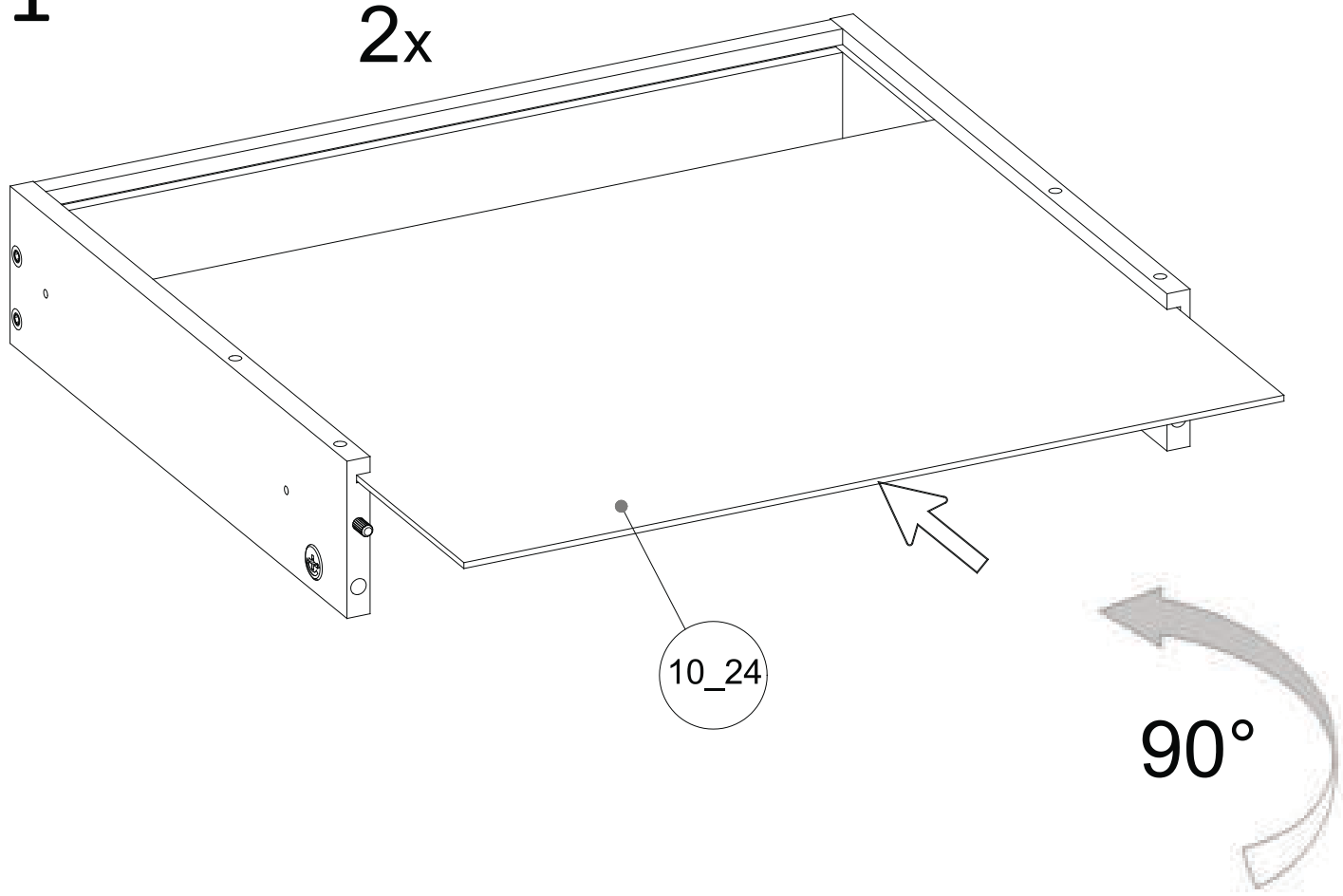

72 ZS10  $\varnothing$ 18  
K-02  
2x2



2x

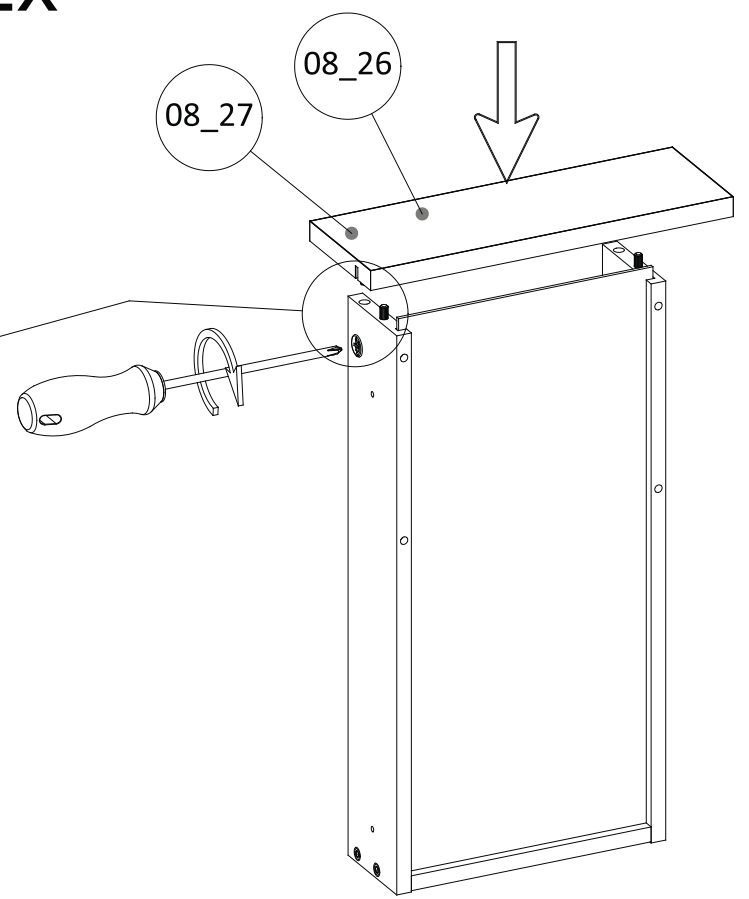
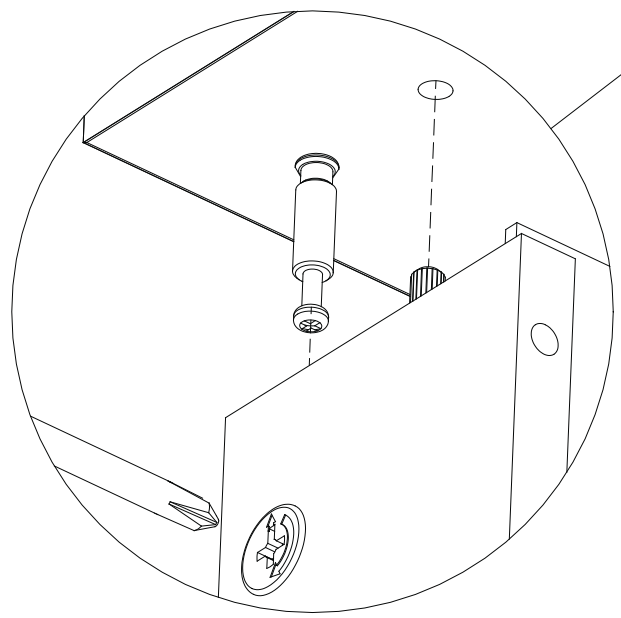
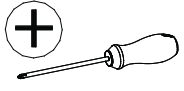

73 TK  
2x2

PQ64 L=450  
H=35  
2x1

WE66 5x9  
2x4

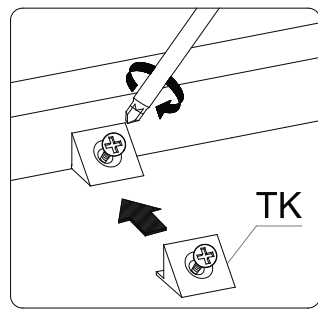
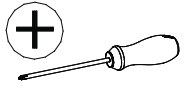

2x

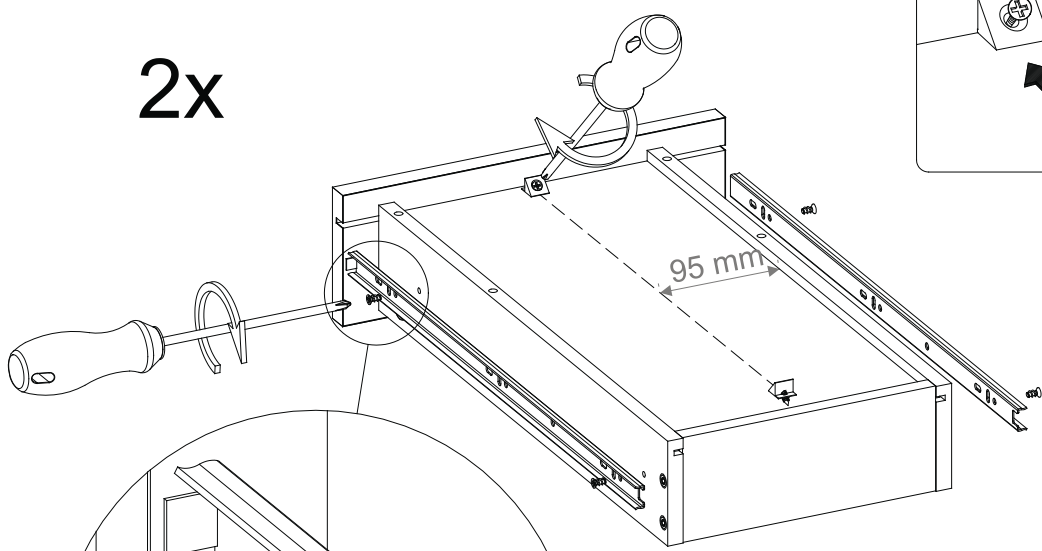

180°

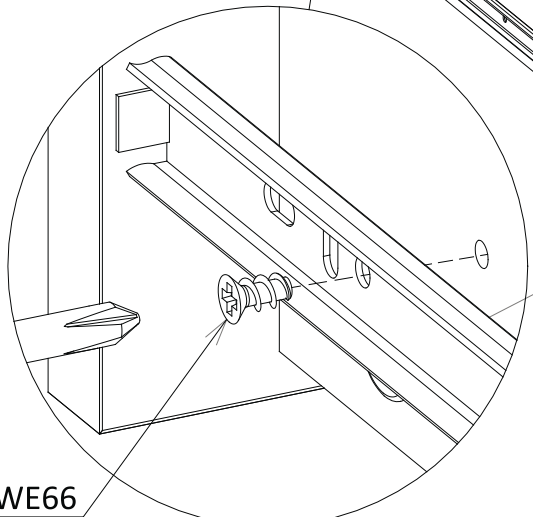

PQ64

WE66

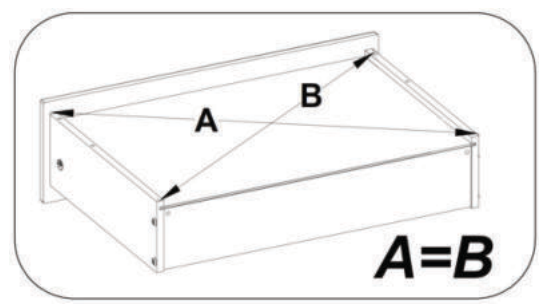

# 74

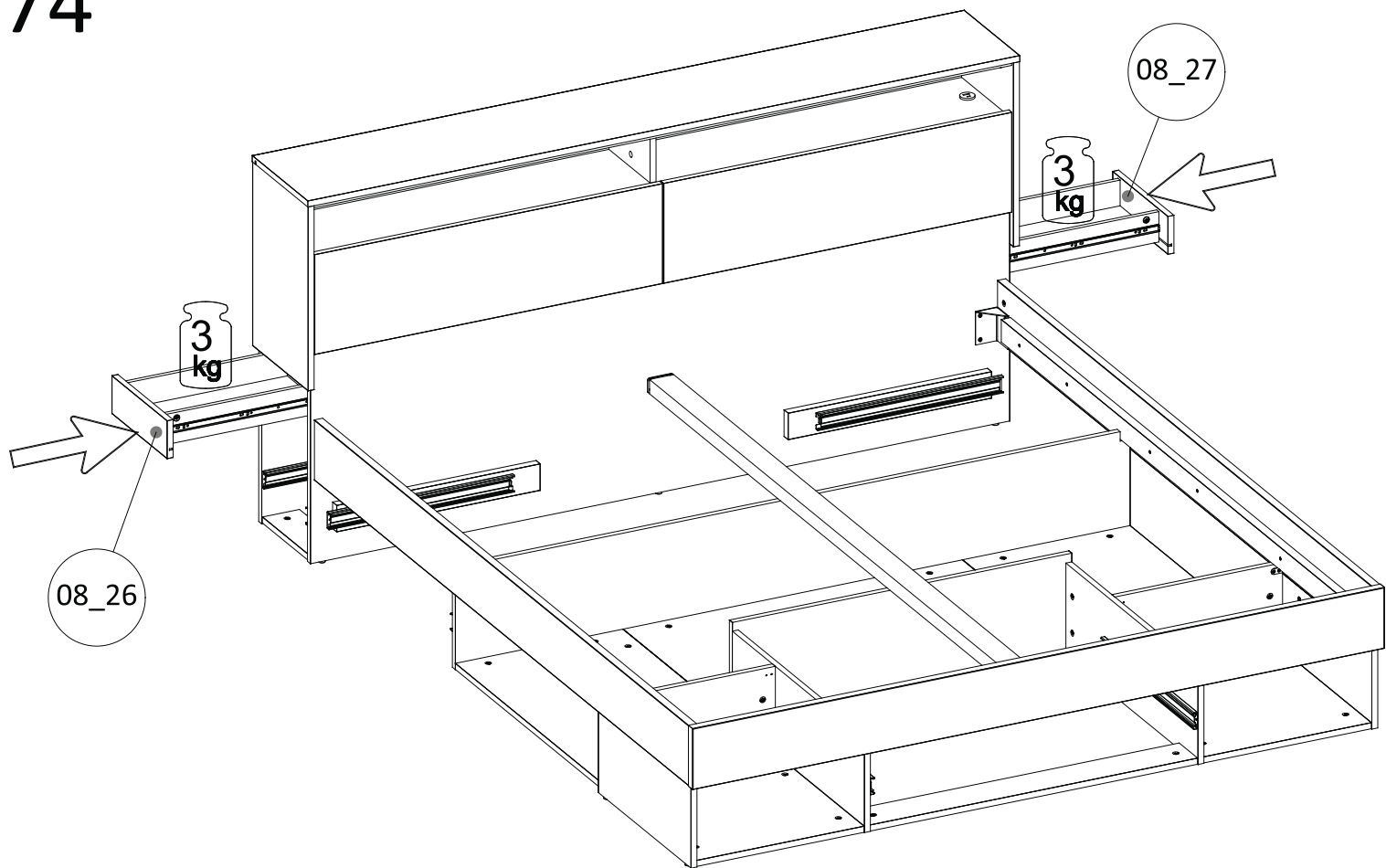

# 75

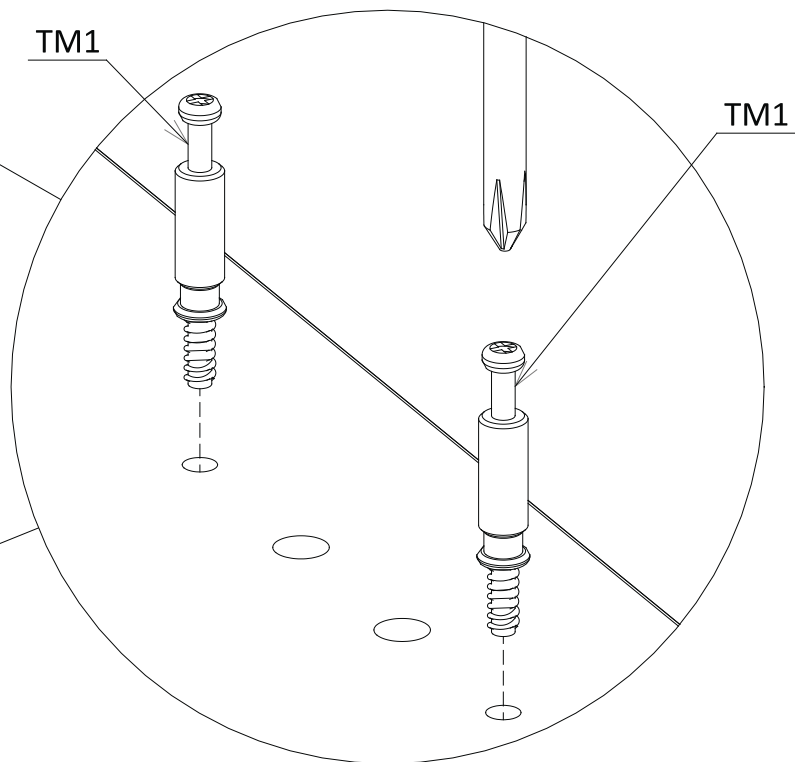
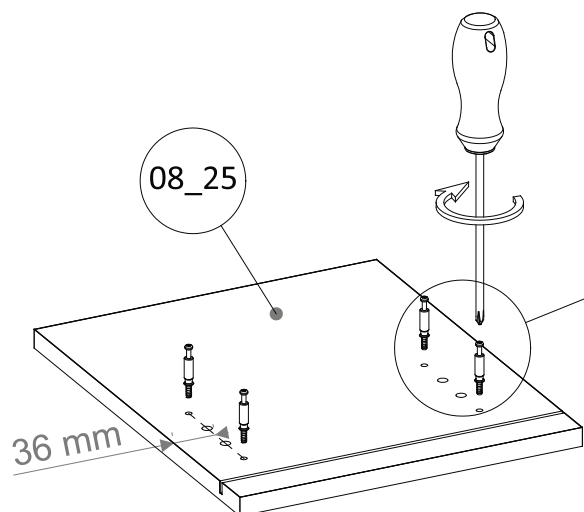
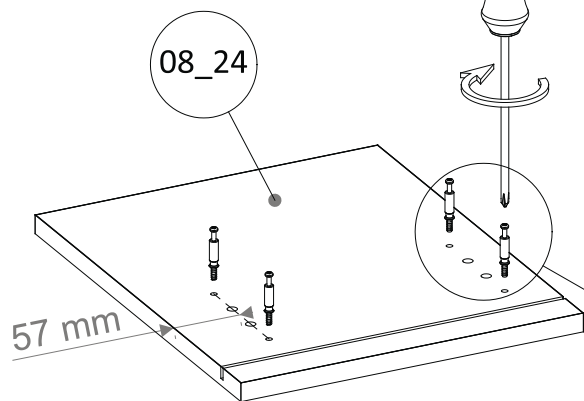
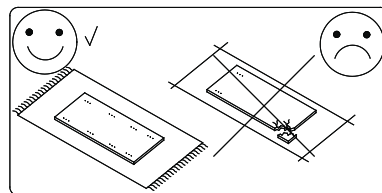
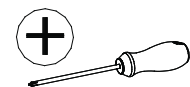
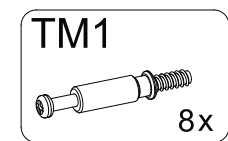

76

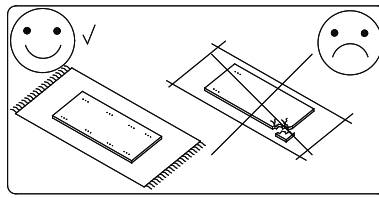
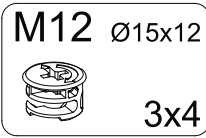
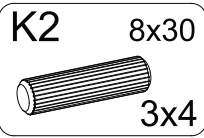

90°

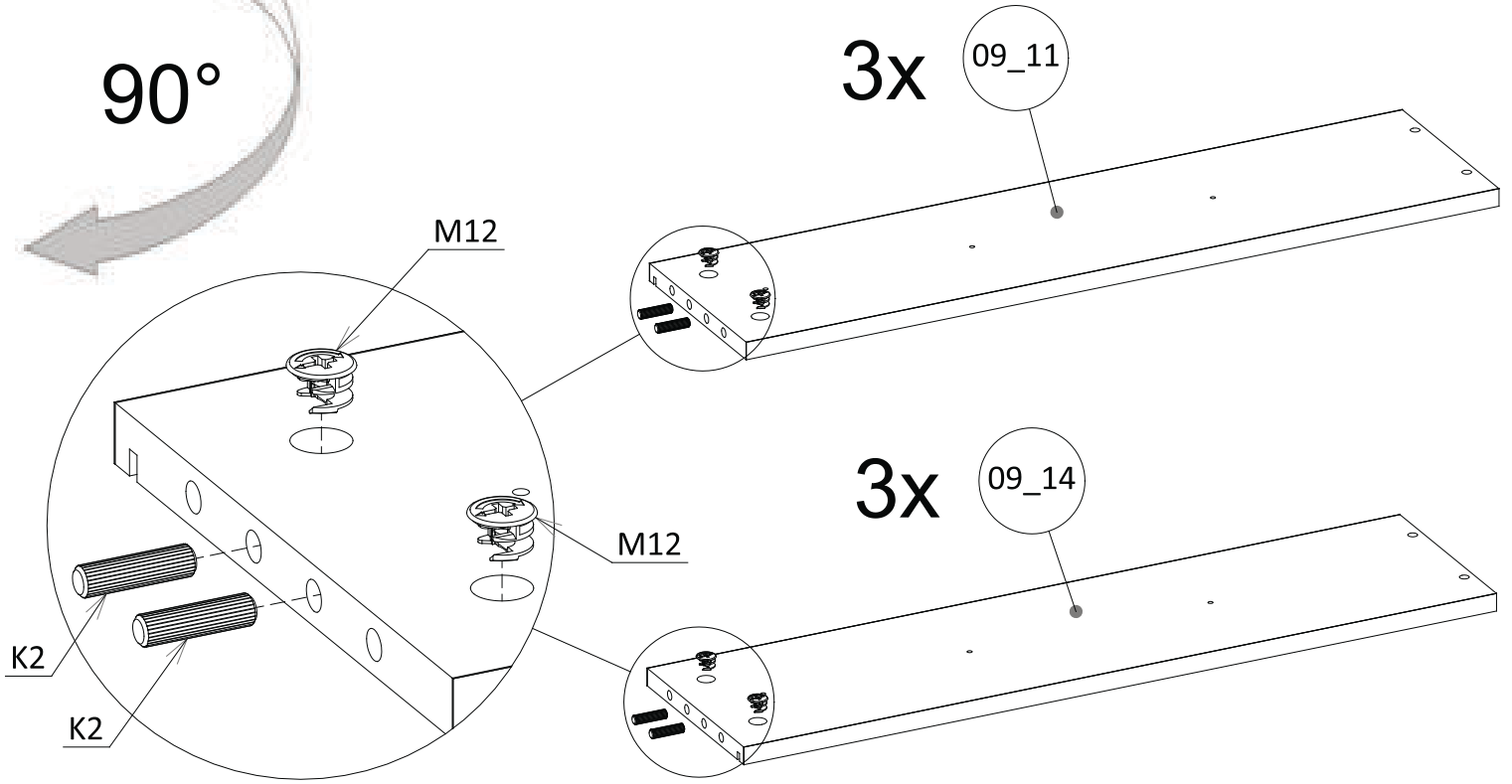

77

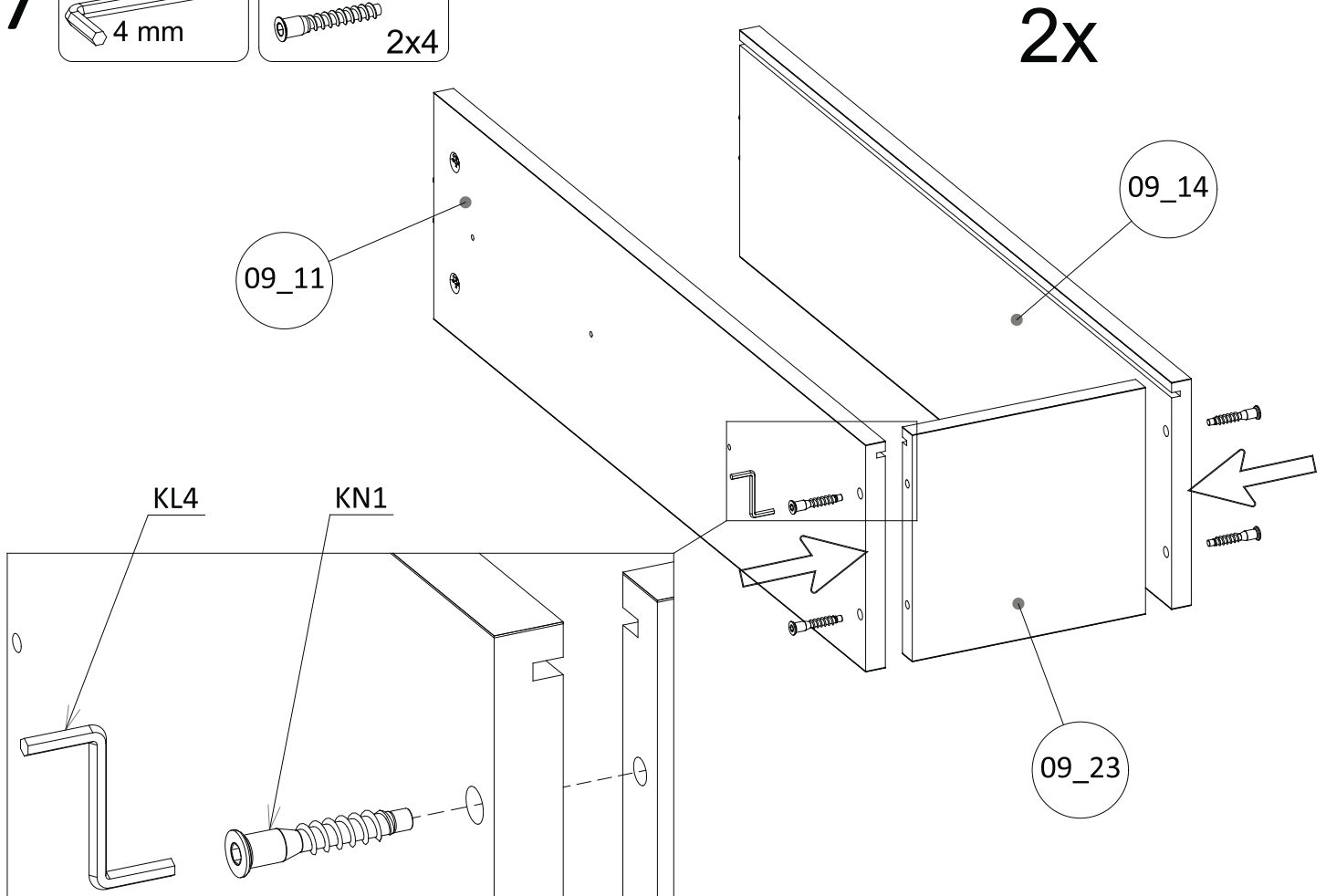
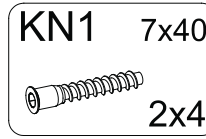
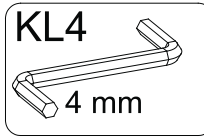

78

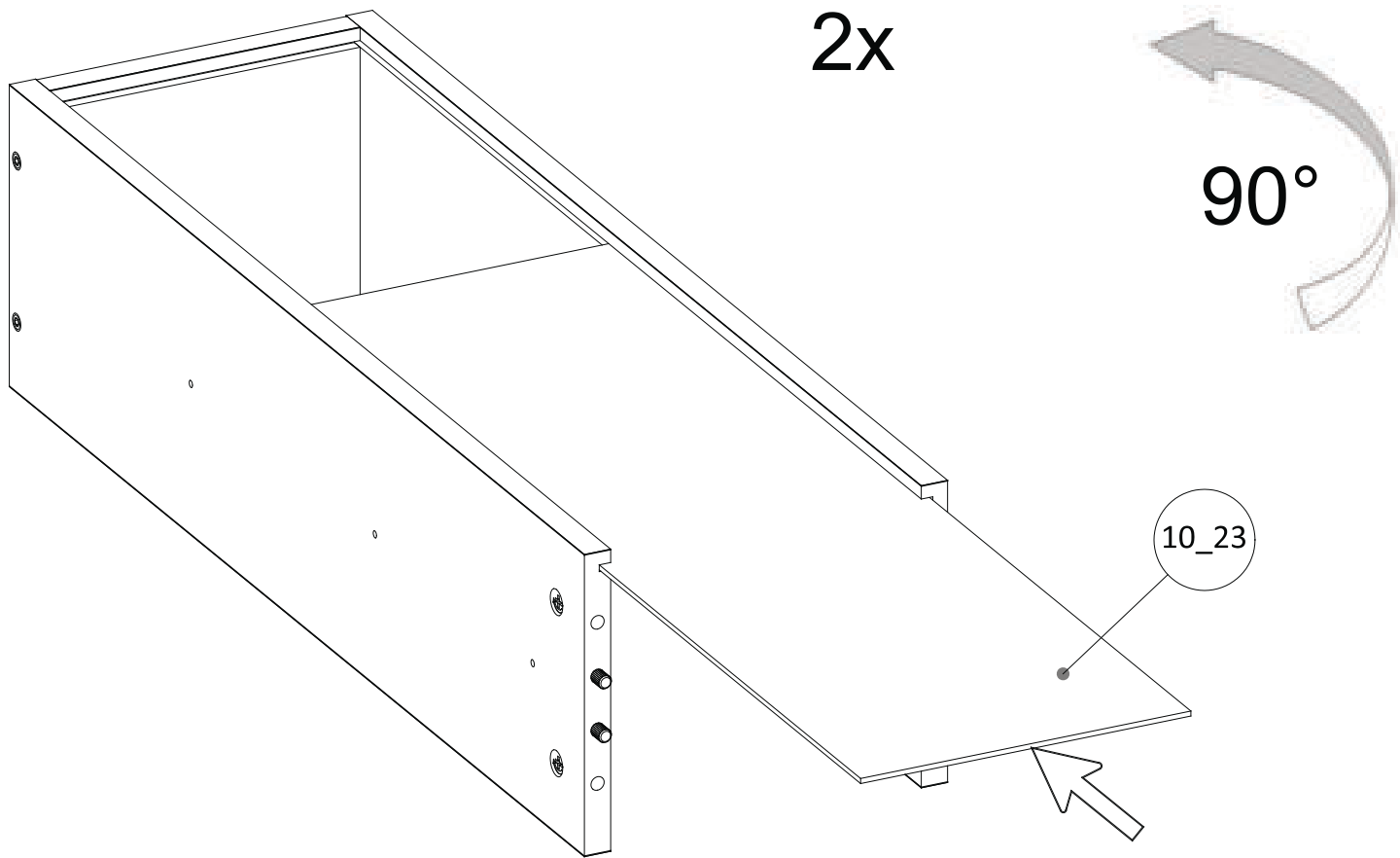

79

ZS12 ø18  
K-02  
2x4

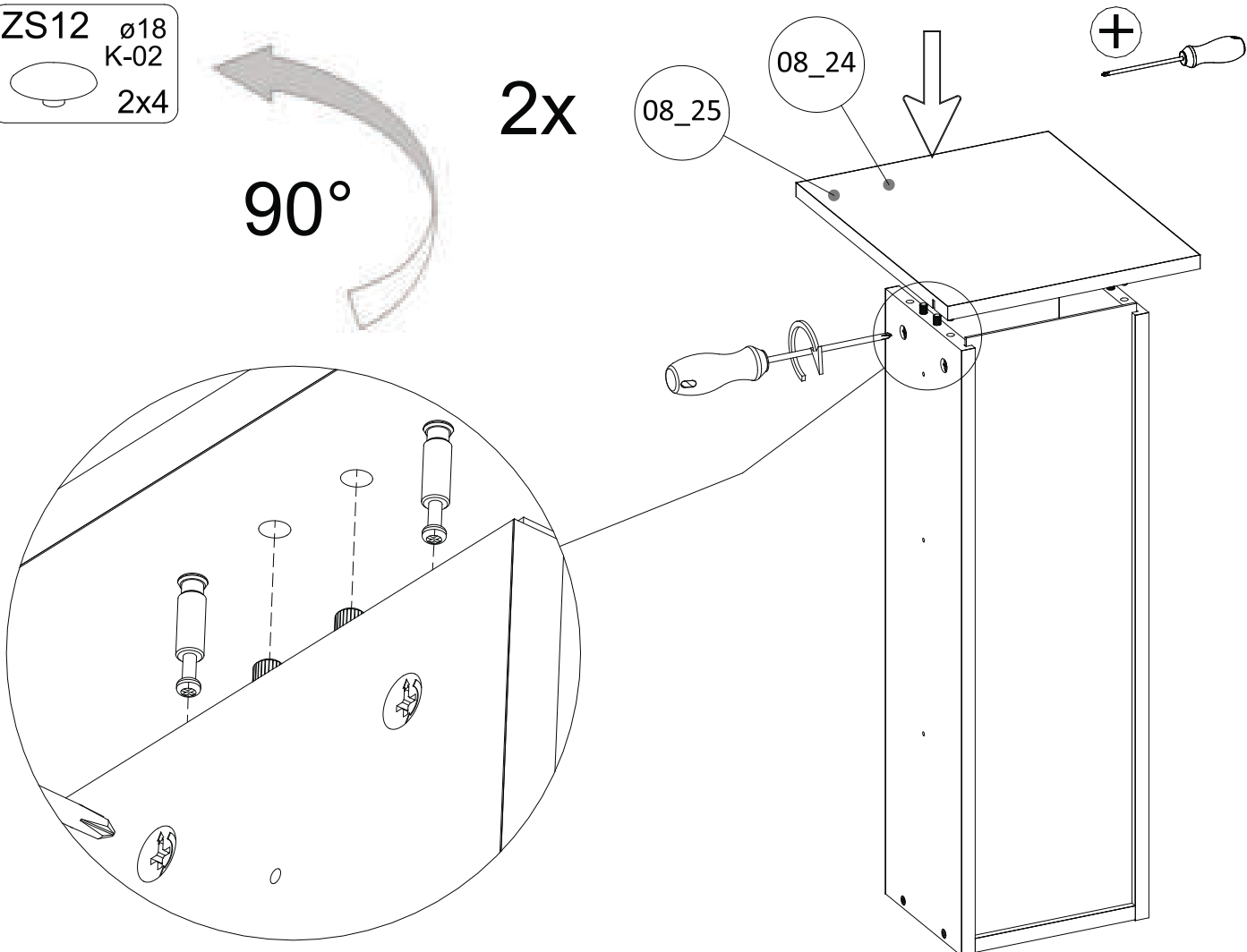

80

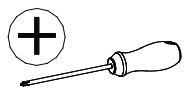
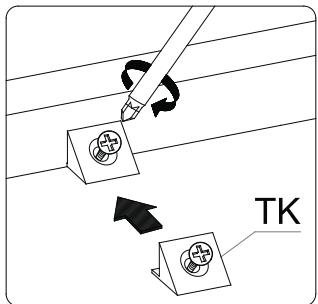
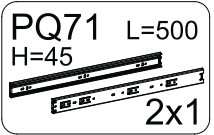
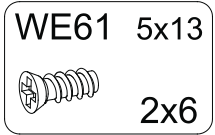
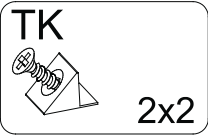

2x

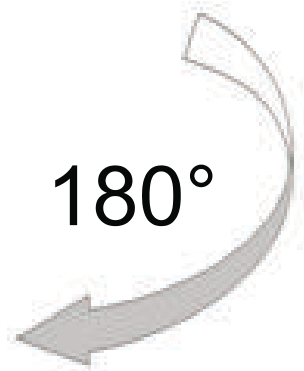
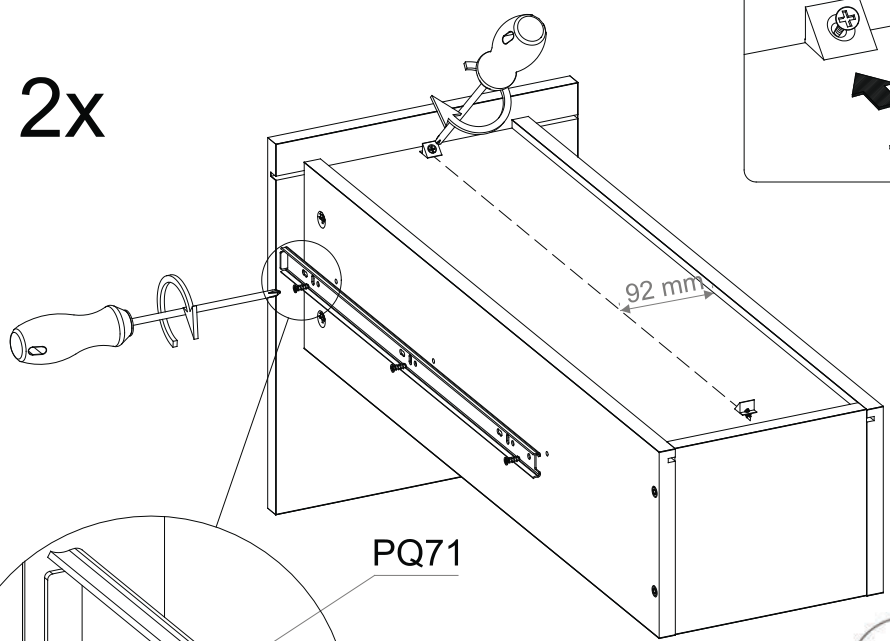

180°

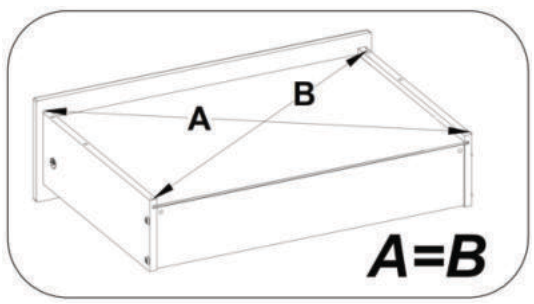
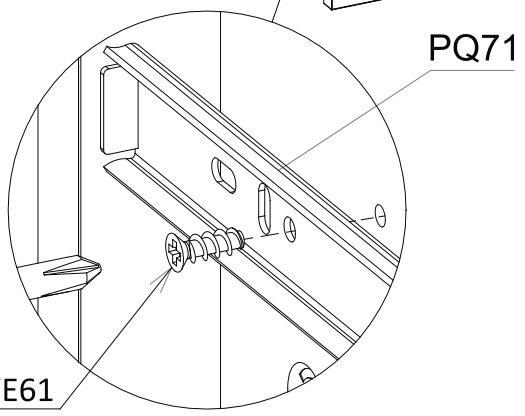

81

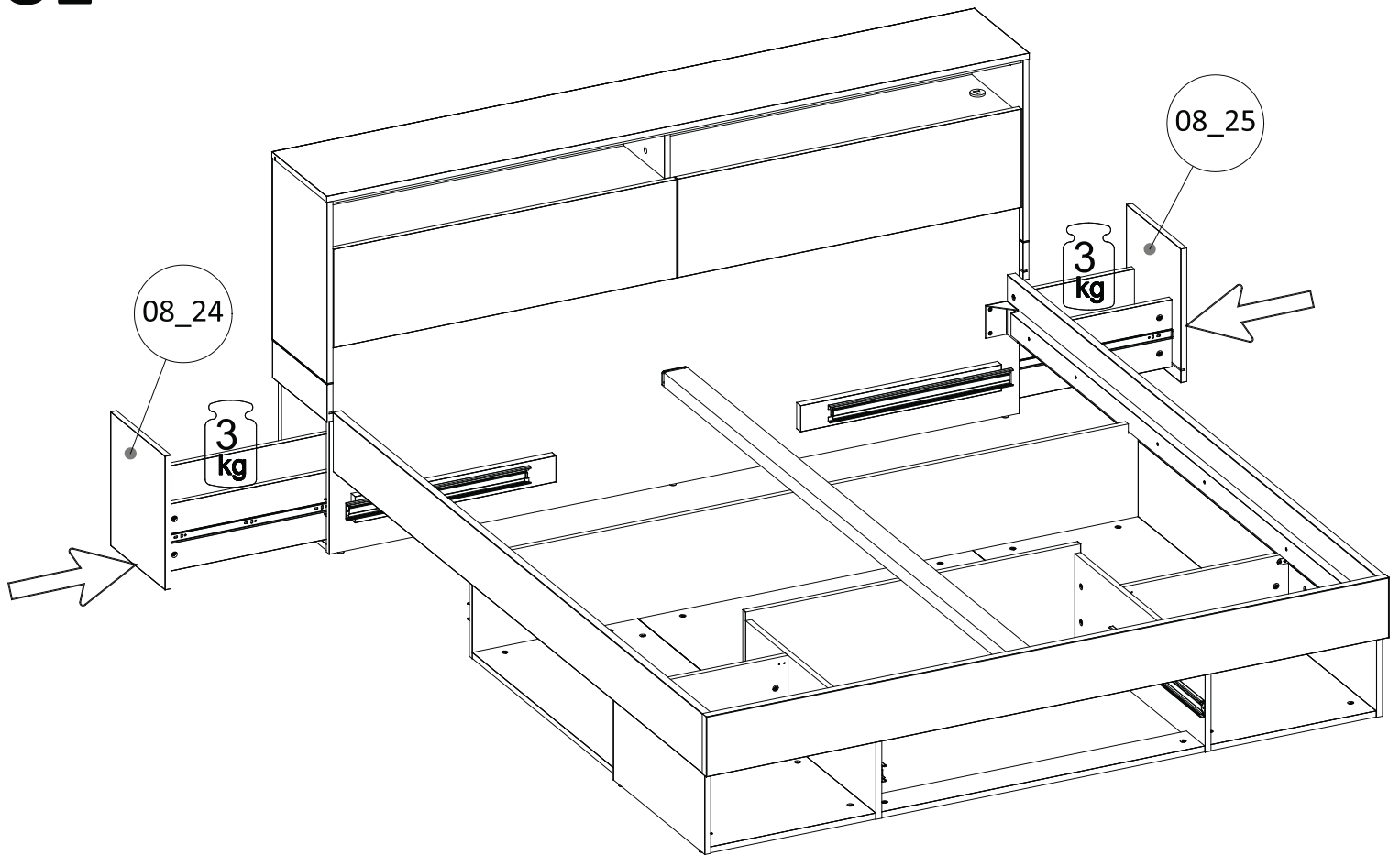

82

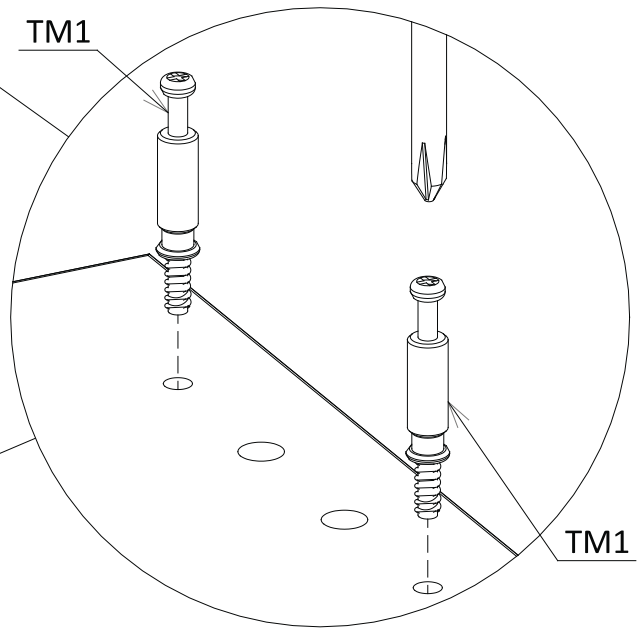
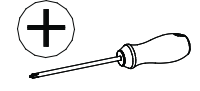
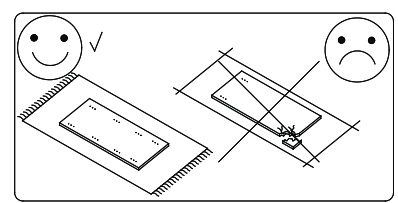
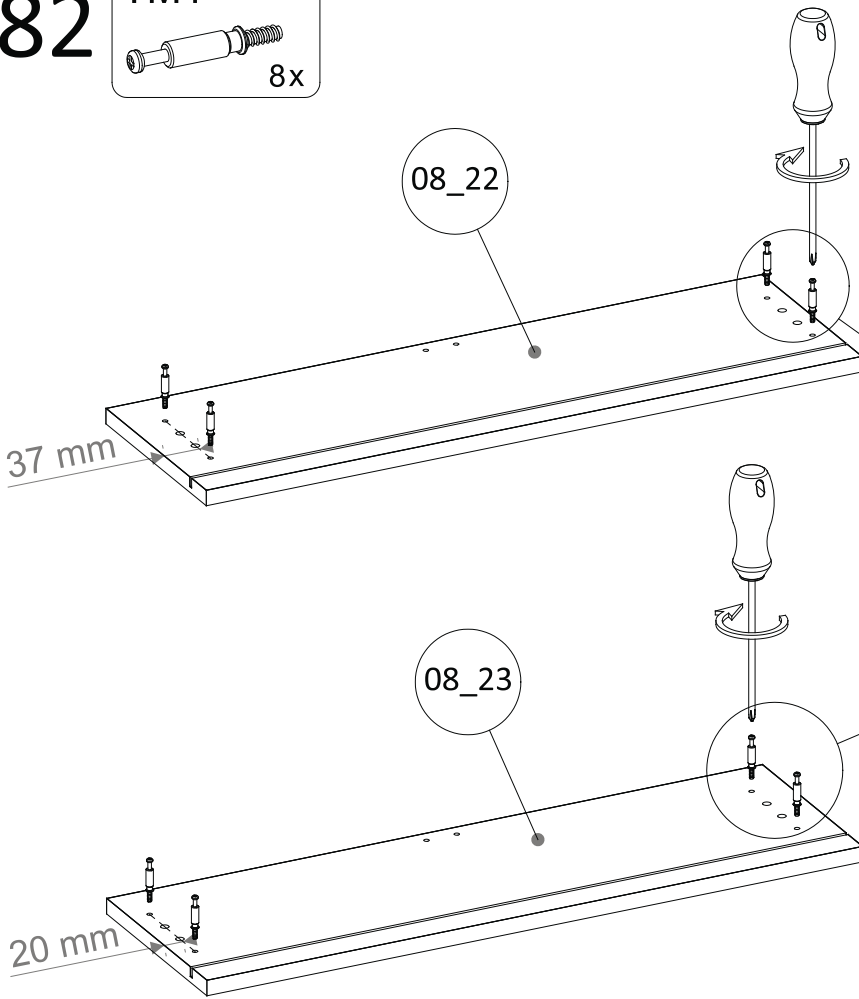
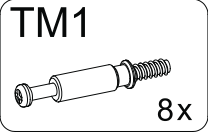

83

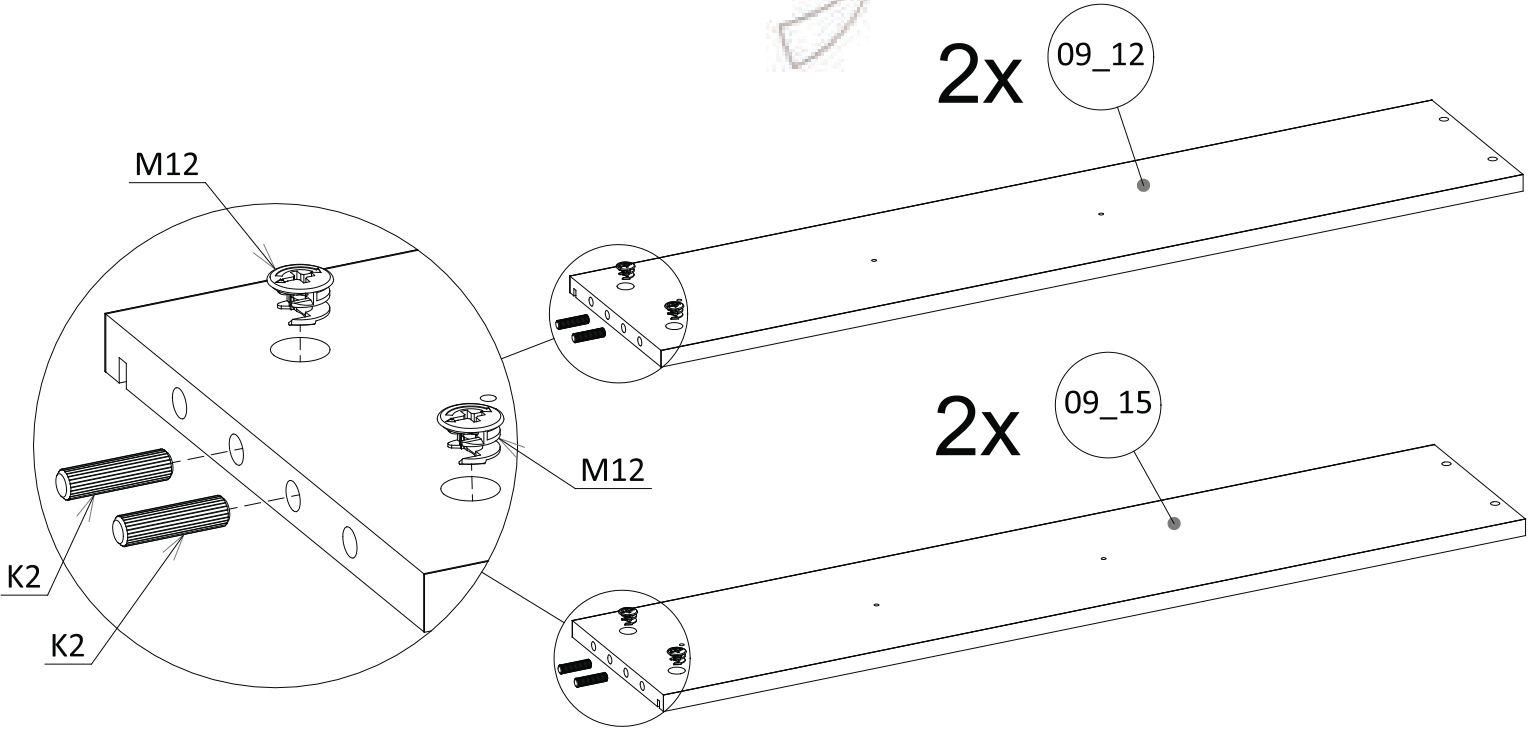
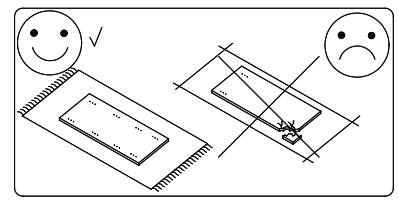
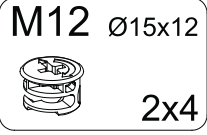
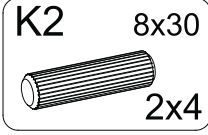

84

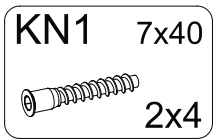
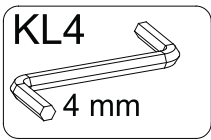

2x

09\_12

09\_15

09\_22

KN1

KL4

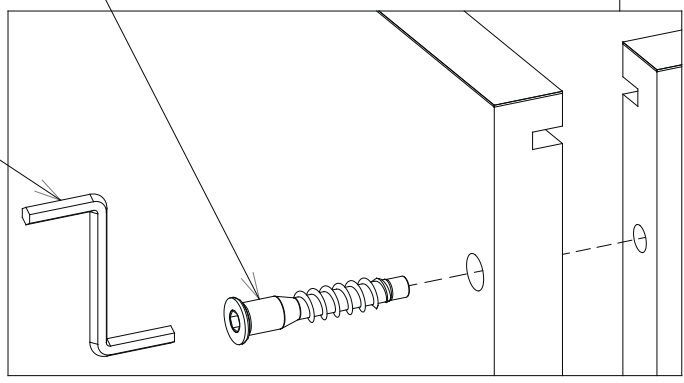

85

2x

90°

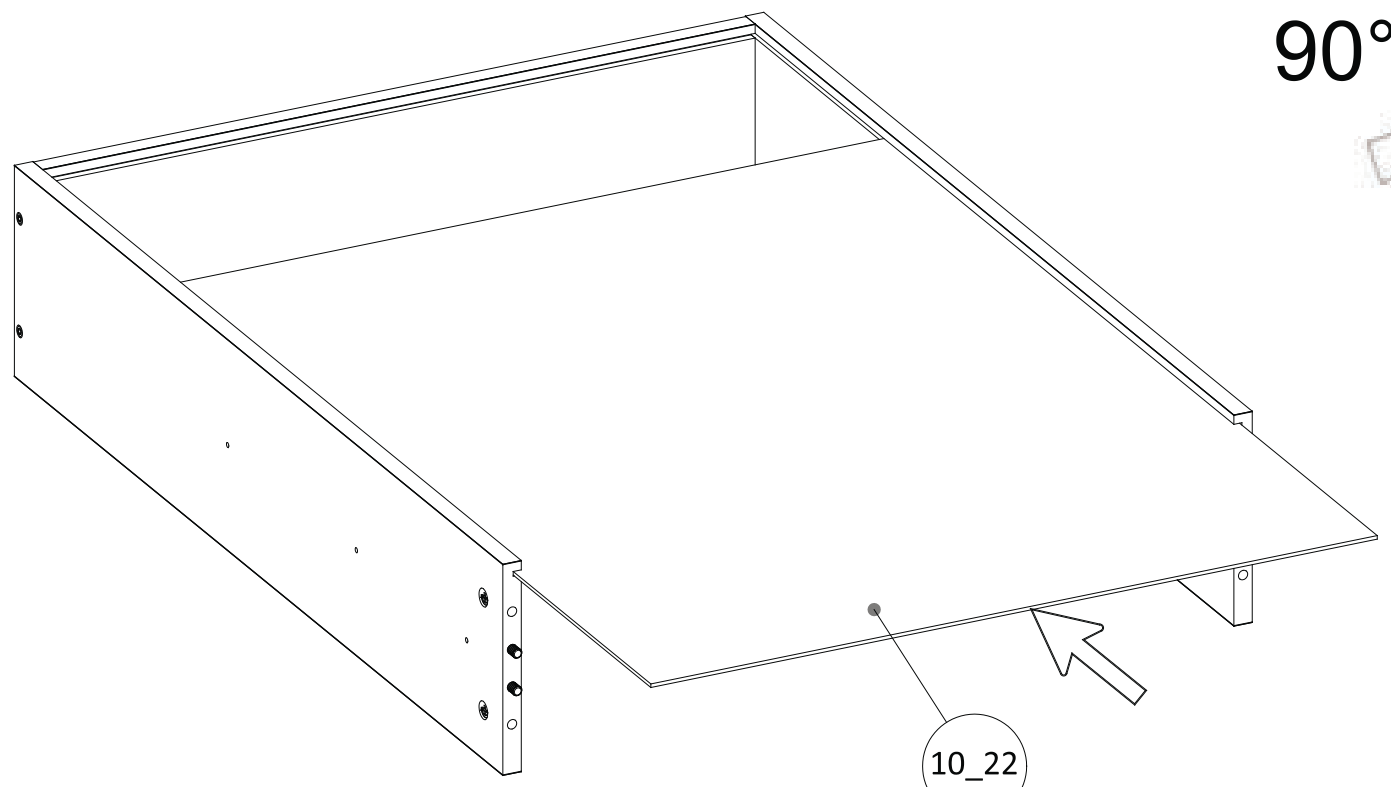

10\_22

86

ZS12  $\phi 18$   
K-02  
2x4

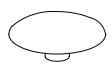
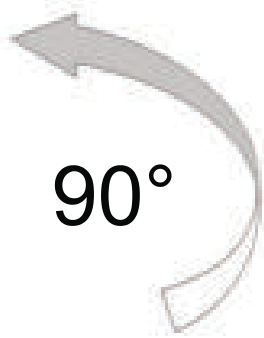

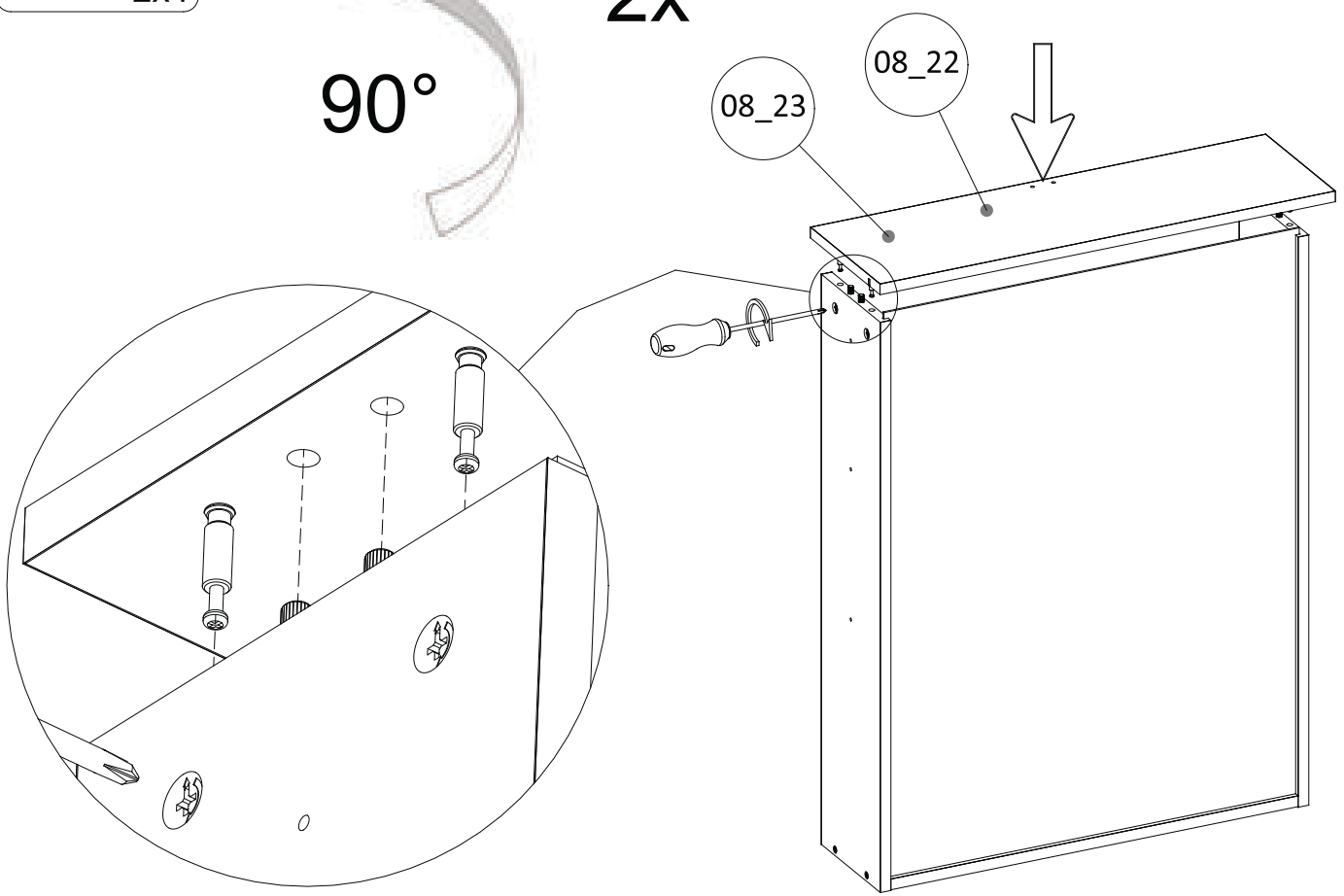
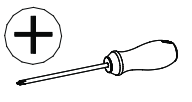

2x



87

TK  
2x4



WSL L=850  
2x1

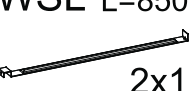

W7 4x13  
2x1

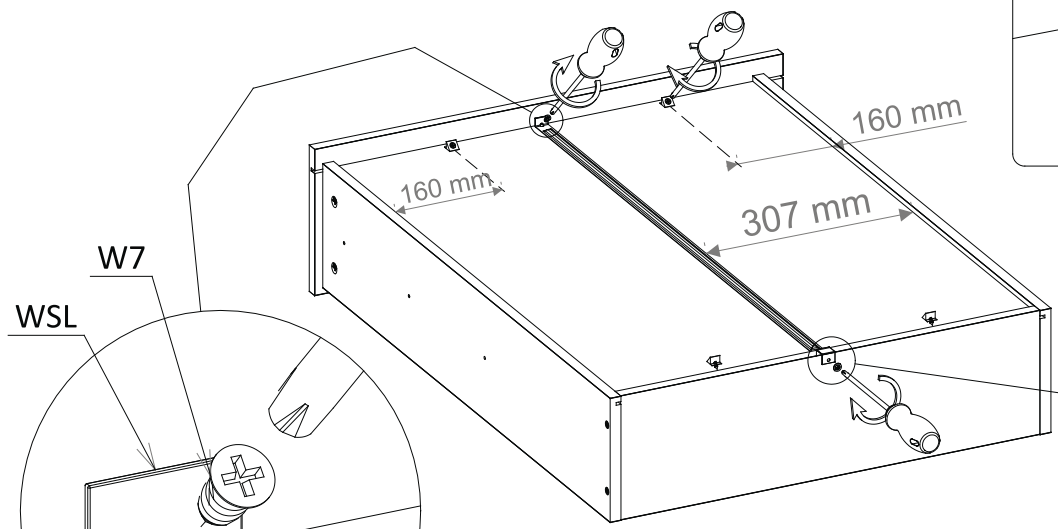
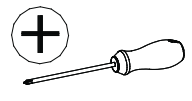
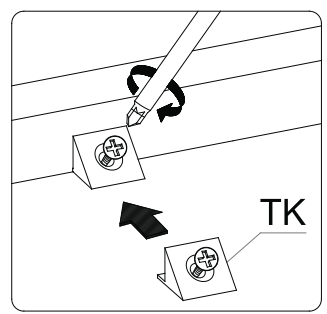

W33 4x13  
2x1

2x

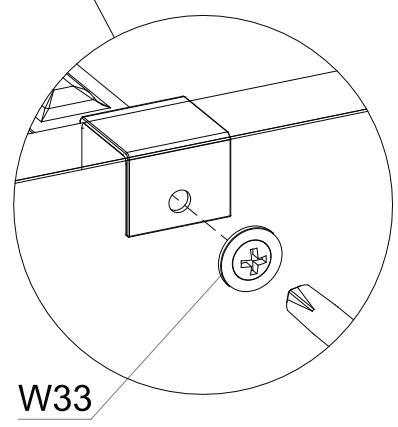
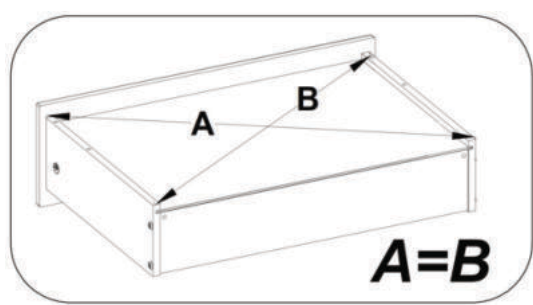

88

WE61 5x13  
2x6

PQ71 L=500  
H=45  
2x1

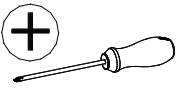

2x

PQ71

WE61

180°

89

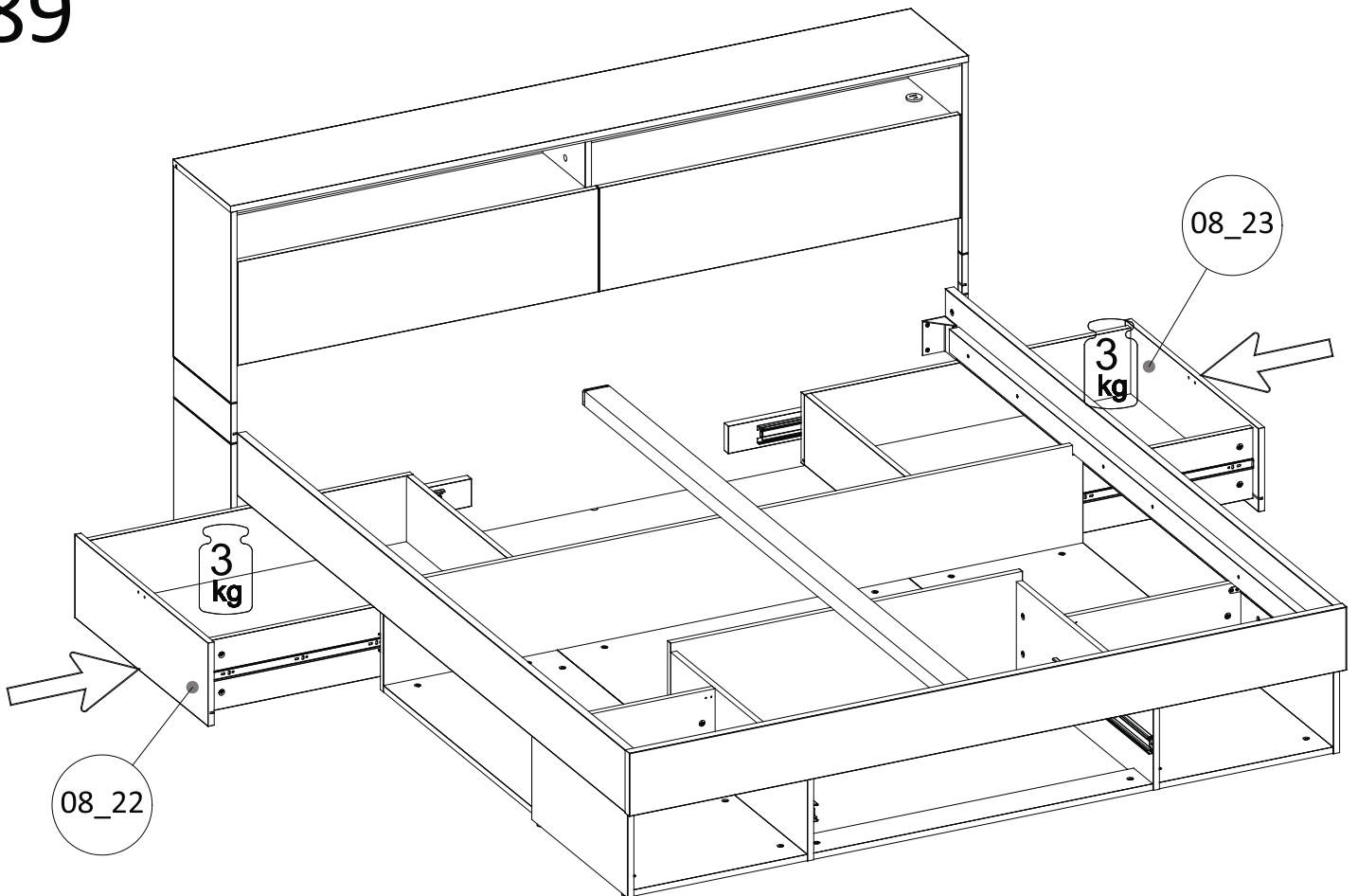

# 90

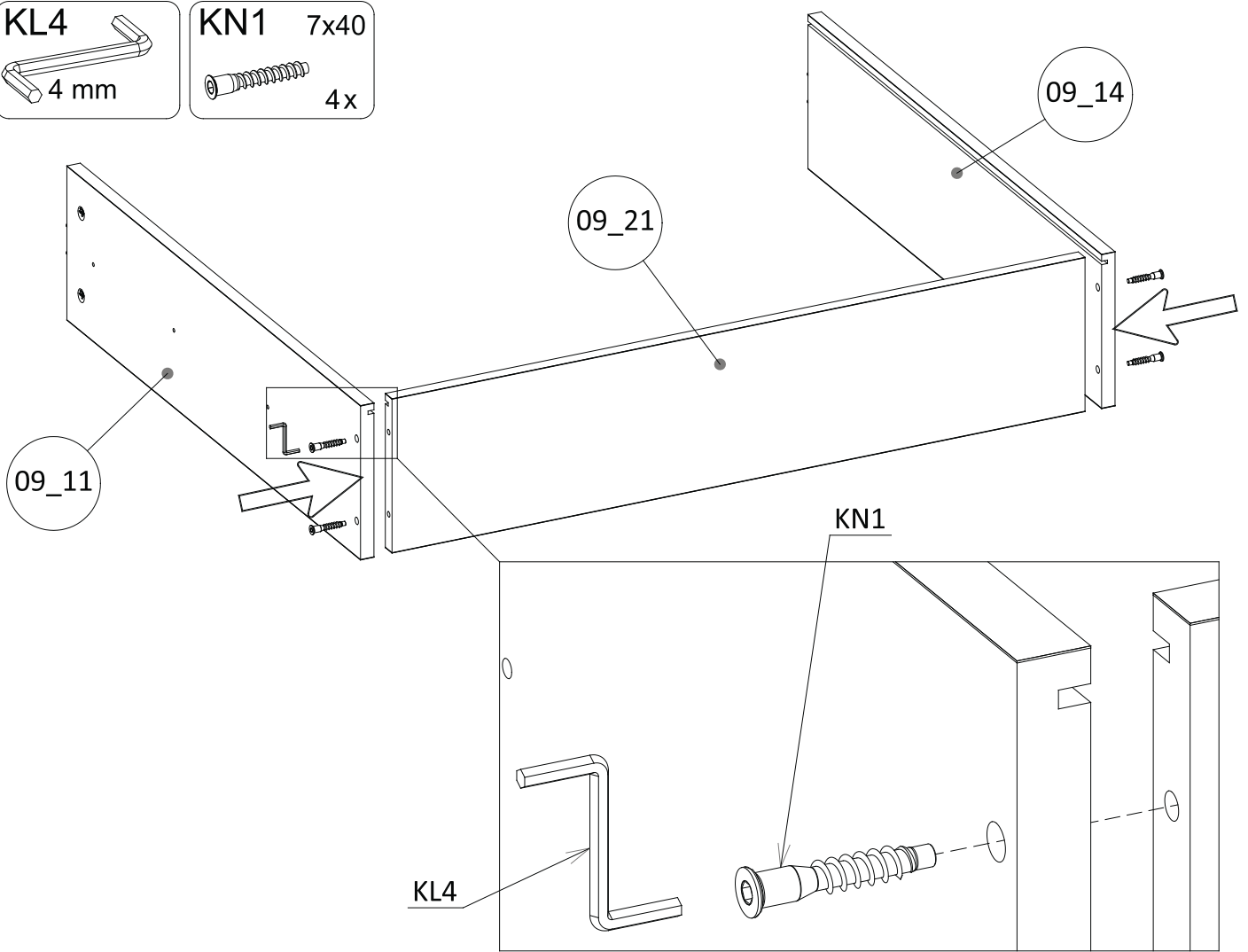
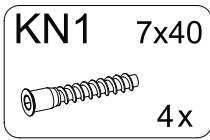
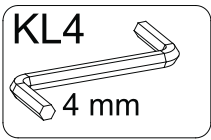

# 91

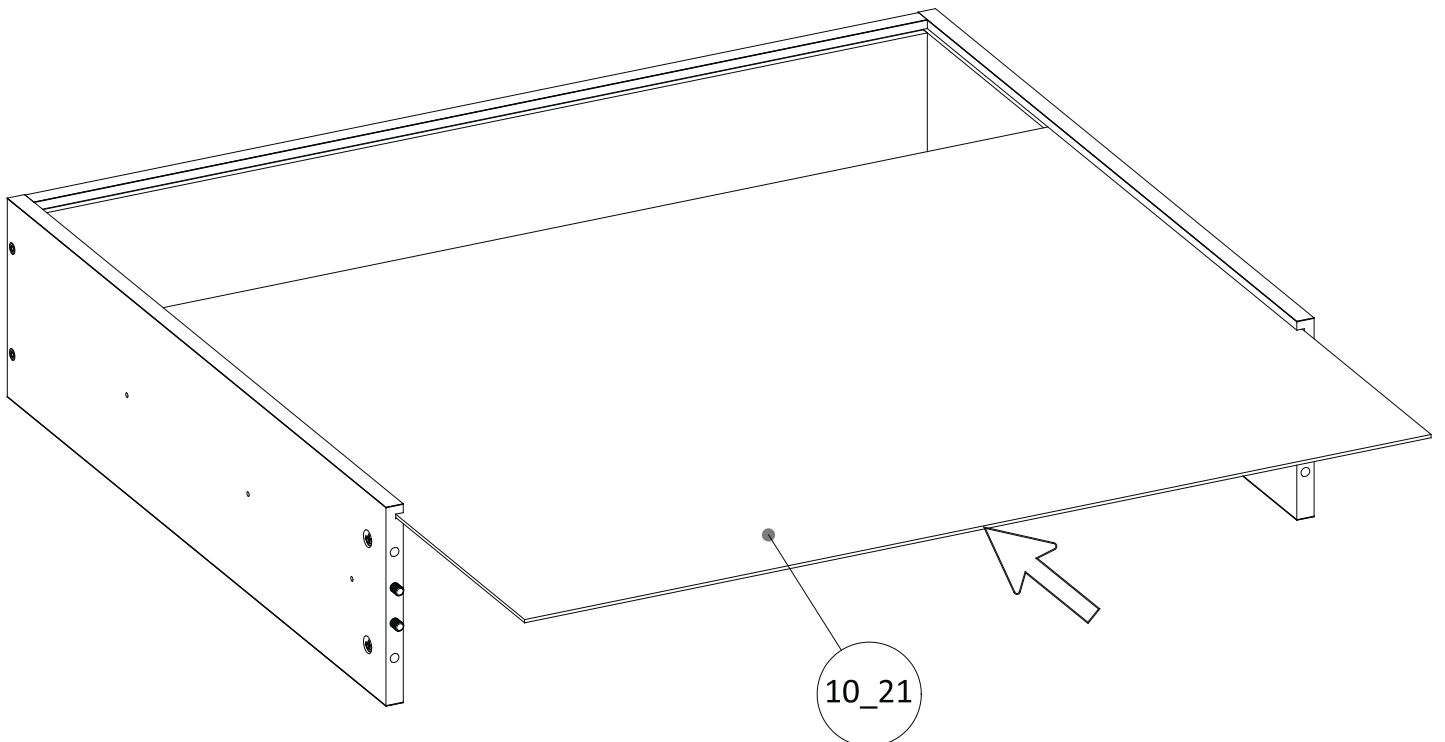

92

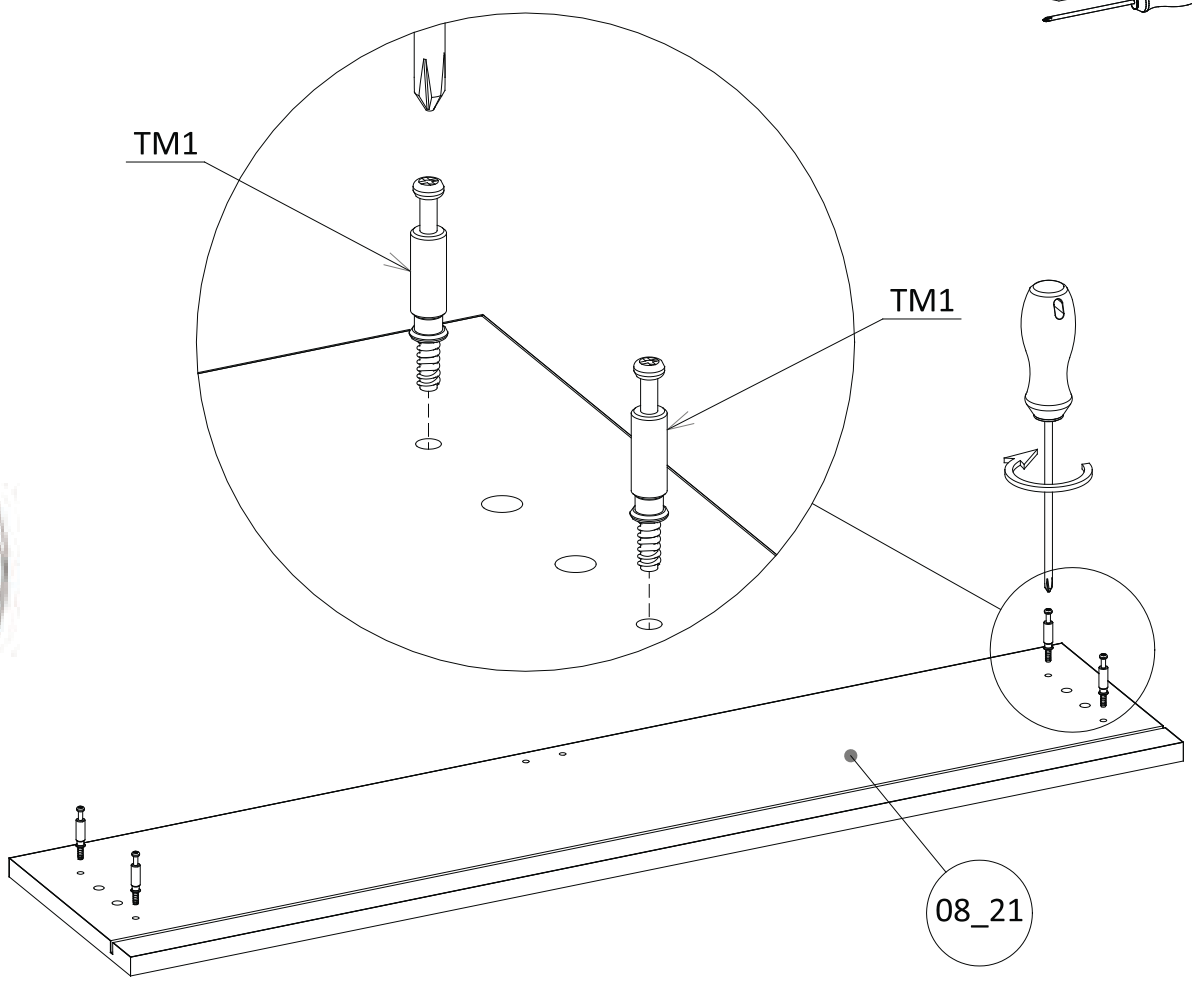
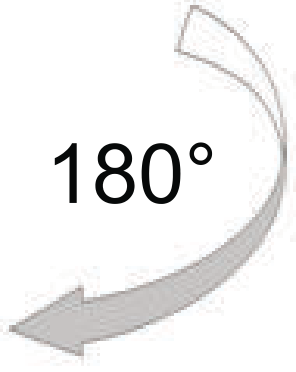
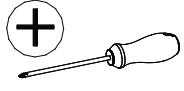
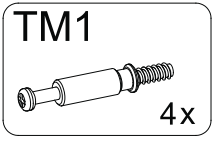

93

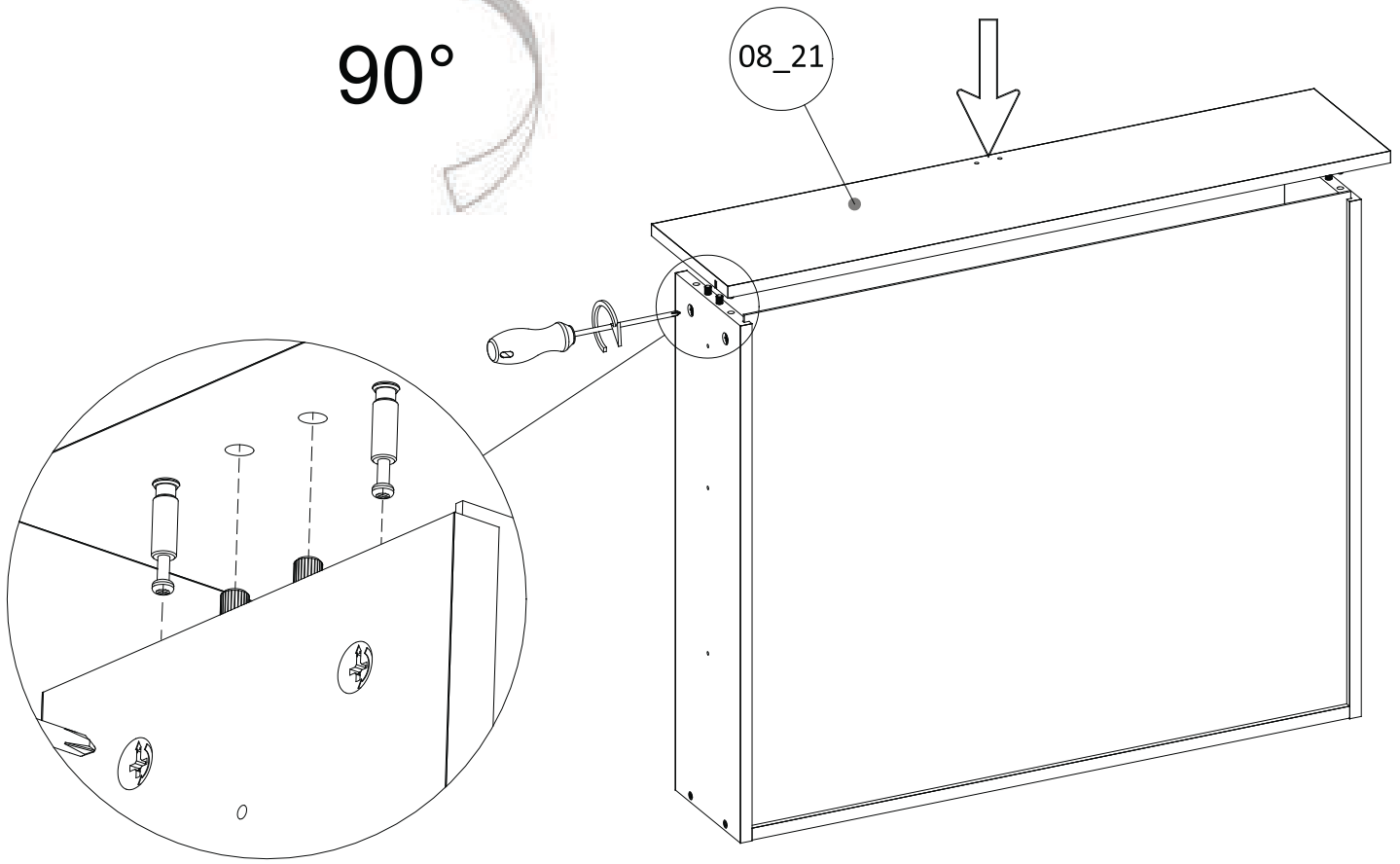
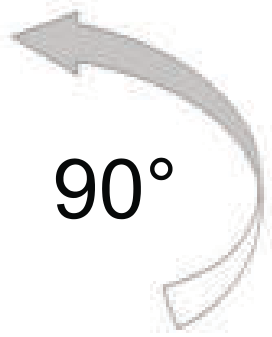
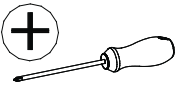
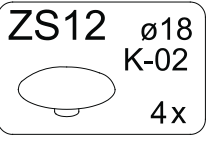

# 94

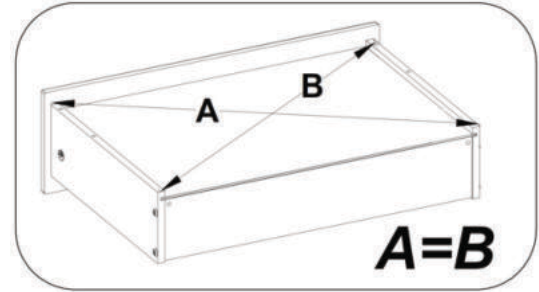
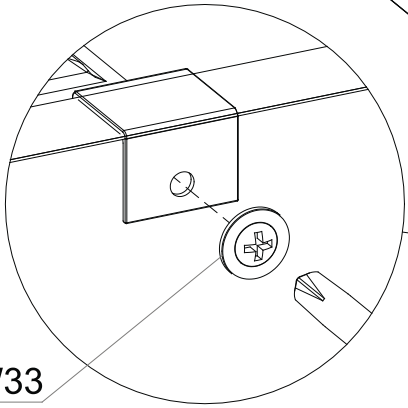
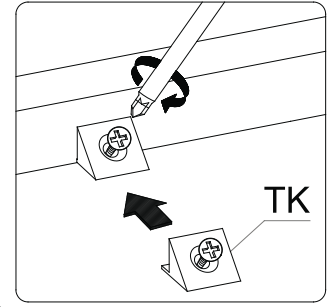
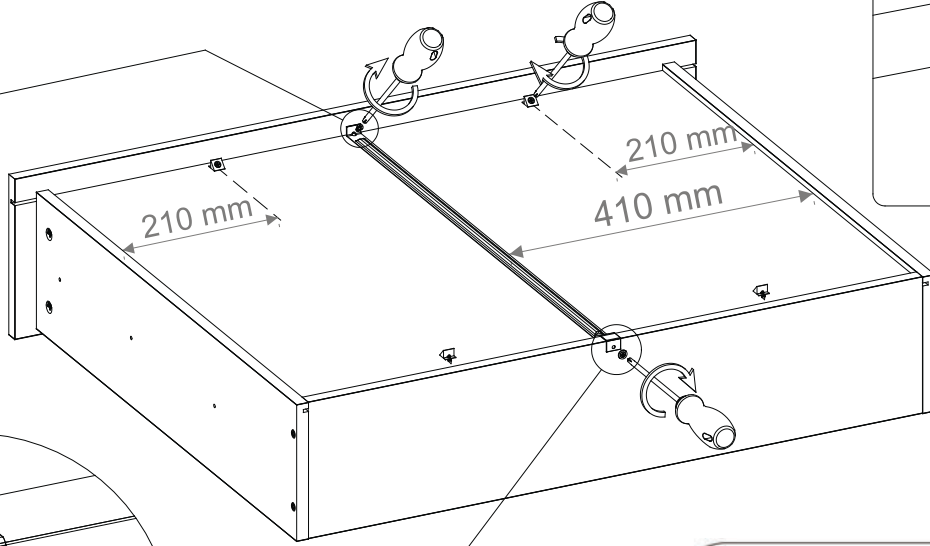
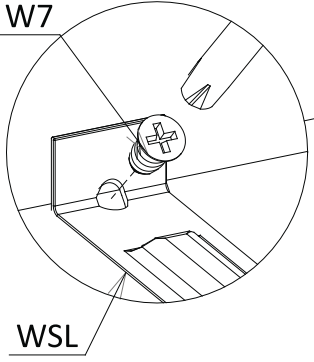
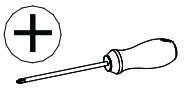
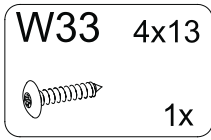
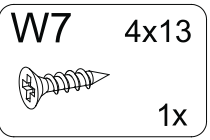
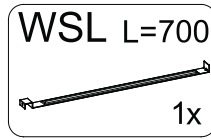
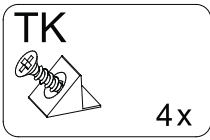

# 95

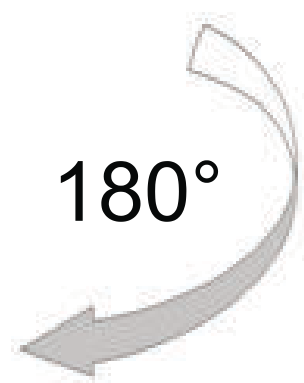
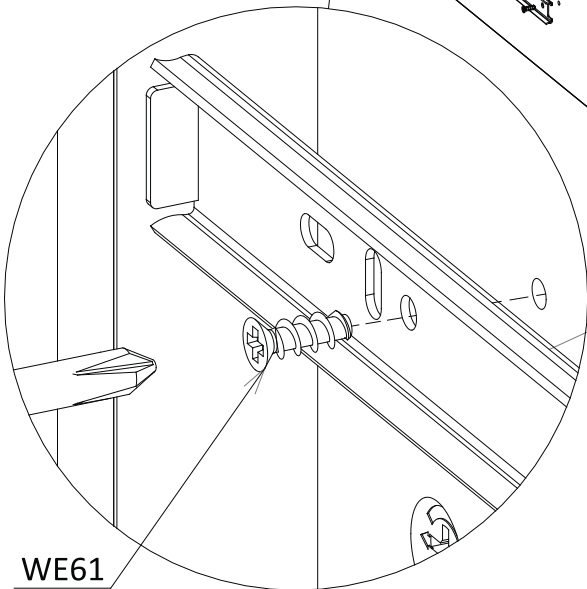
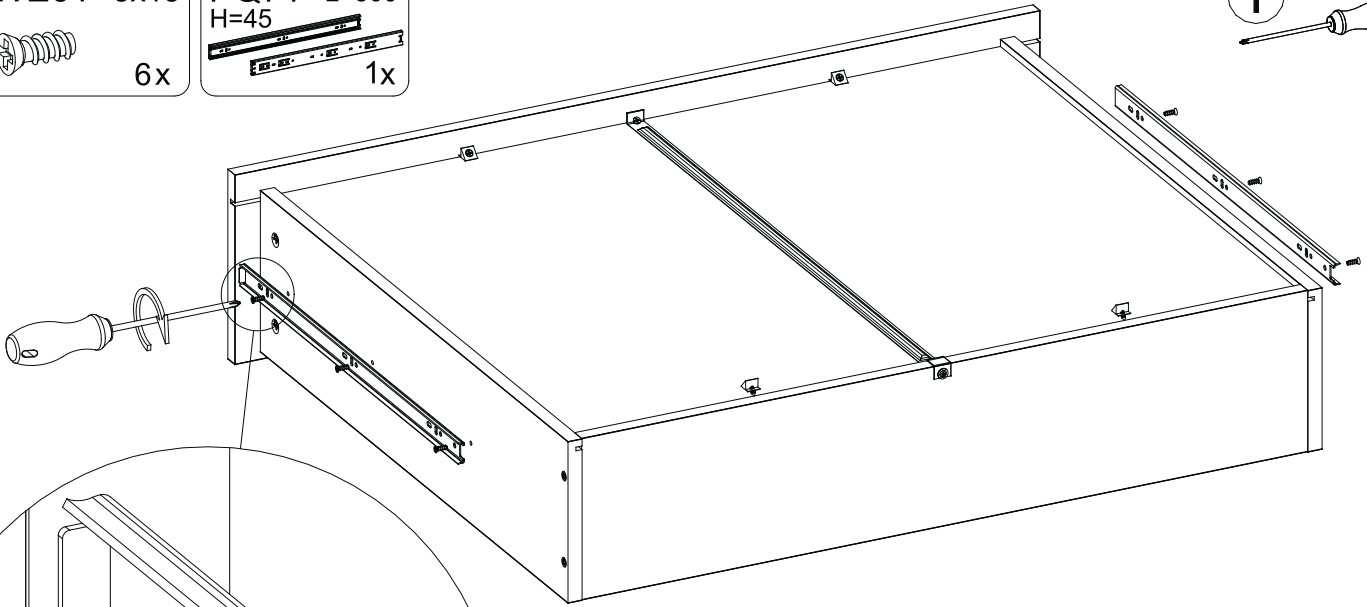
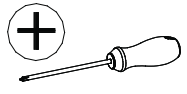
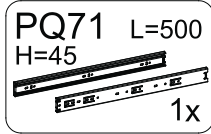
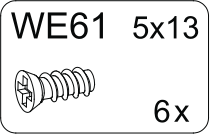

96

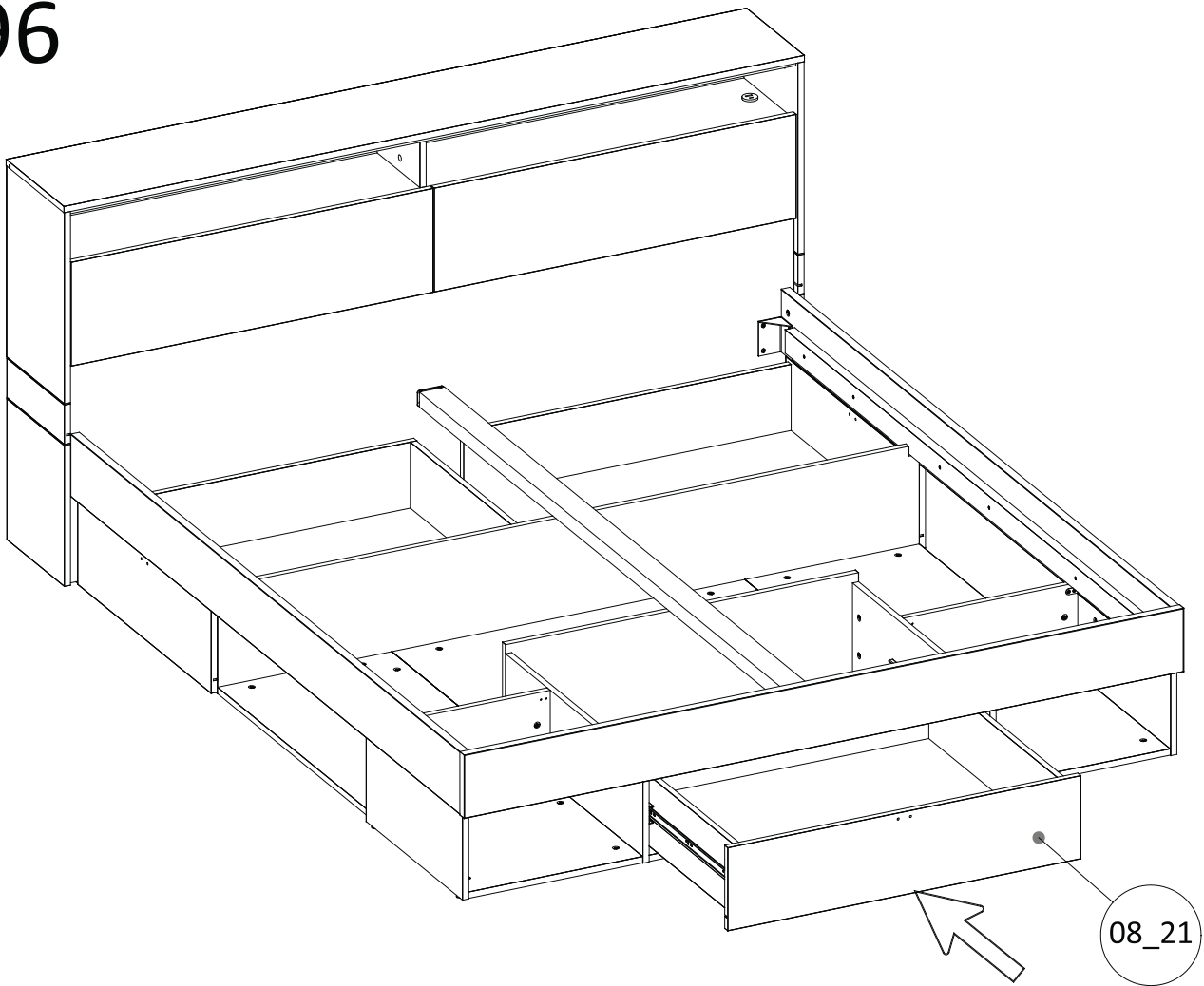

97

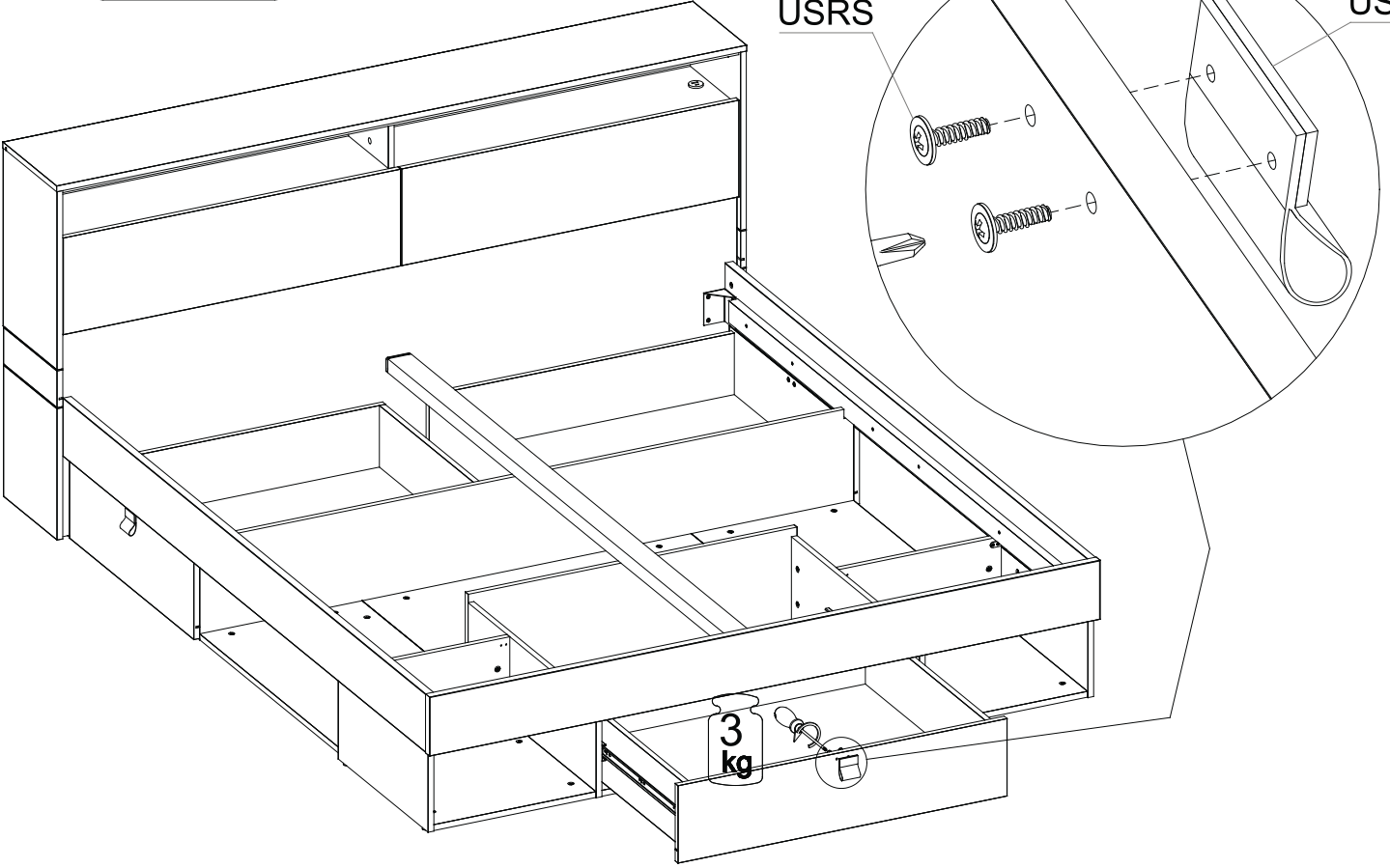
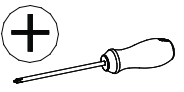
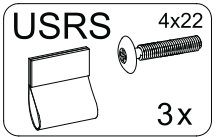

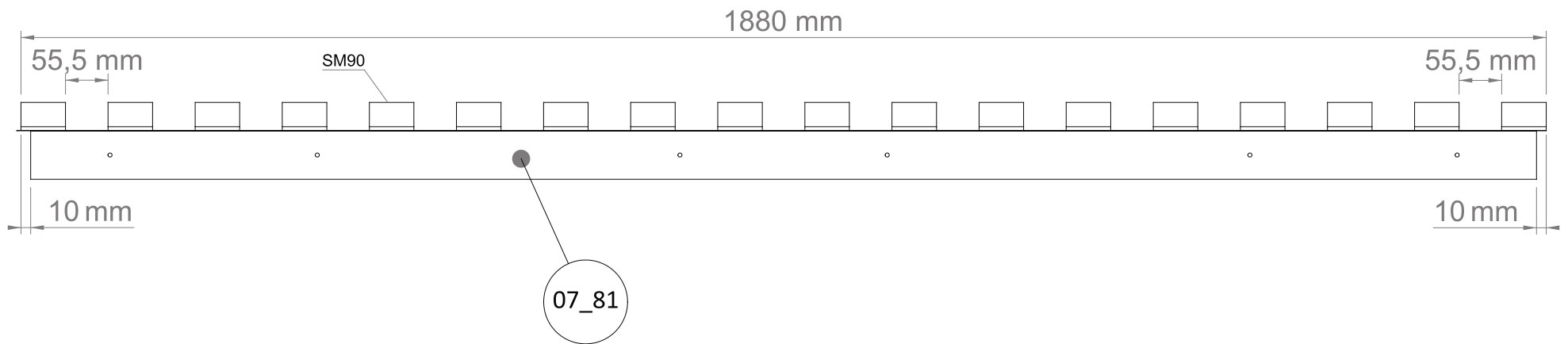

98

W5 3,5x25  
24x

SM90  
LR=896 mm  
2x

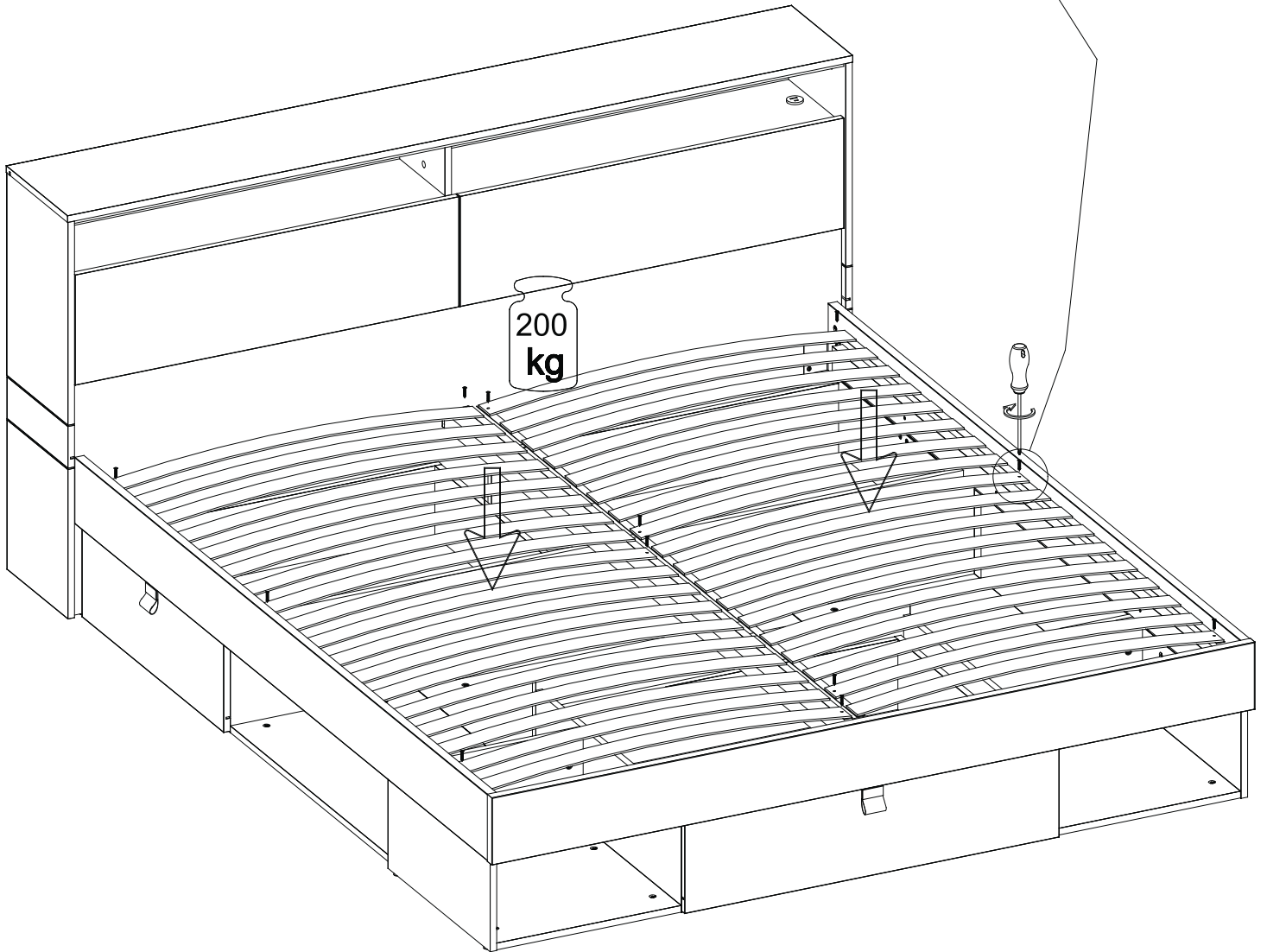
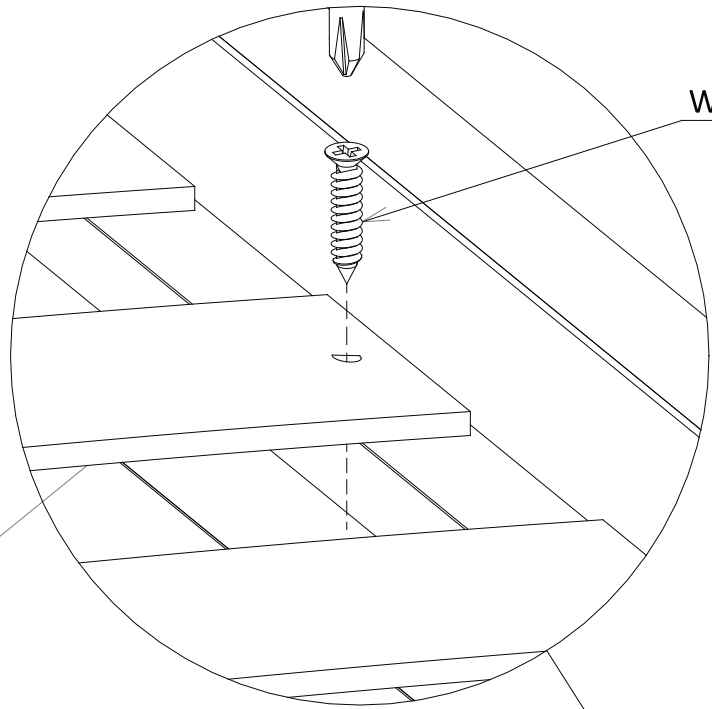
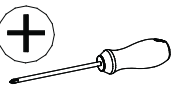

## PL

### Zasady użytkowania mebli:

1. Meble powinny być użytkowane zgodnie z ich przeznaczeniem.
2. Meble należy użytkować pomieszczeniach suchych, zamkniętych i zabezpieczonych przed szkodliwymi wpływami atmosferycznym oraz bezpośrednim działaniem promieni słonecznych.
3. Mebli nie należy ustawiać w odległości mniejszej niż pół metra od czynnych grzejników.
4. Wymagane jest równe wypoziomowanie, ustawienie mebli na stabilnym podłożu.
5. Sposób montażu mebli, ilość elementów i akcesoriów niezbędnych do montażu określa karta informacyjna znajdująca się w opakowaniu danego typu mebla. Chyba, że meble zgodnie z życzeniem Klienta zostały dostarczone zmontowane. W tym wypadku instrukcje montażu nie są załączane do mebli.
6. Na powierzchniach mebli nie należy stawiać przedmiotów wilgotnych.
7. Po zmontowaniu mebli należy wyregulować drzwi na prowadnicach.

### Konserwacja i czyszczenie:

1. Powierzchnie wykonane z laminatu, oraz lakierowane czyścić miękką tkaniną.
2. Do pielęgnacji powierzchni nie należy stosować żadnych środków chemicznych, lub szorstkich ścierek.

Szanowny kliencie, gdyby brakowało jakiejś części, lub byłaby uszkodzona proszę to oznaczyć na instrukcji montażowej i przesłać razem z reklamacją. Jeżeli uszkodzony element będzie zamontowany na stałe reklamacja nie będzie uznana.

## CZ

### Základy používání nábytku

1. Nábytek by měl být používán k určenému účelu.
2. Nábytek by měl být používán v místnostech suchých, uzavřených a chráněných před škodlivými povětrnostními vlivy a před přímým slunečním zářením.
3. Nábytek by neměl být postaven na méně než půl metru před aktivními radiátory.
4. Požadovane je umístění nábytku na stabilním, vyrovnaném povrchu.
5. Návod na montáž nábytku počet součástí a příslušenství nezbytného k montáži uveden na informačním listu, nacházejícím se v obalu určeného nábytku. V případě že na přání zákazníka nábytek byl dodán smontovaný návod k montáži se nepřipojuje.
6. Na povrch nábytku nepokládejte vlhké předměty.
7. Po smontování nábytku seřdit (vyrovnat) dveře pomocí kolejničky.

### Údržba a čištění:

1. Povrchy z lamina a lakované čistit měkkým hadříkem.
2. K údržbě povrchu nepoužívejte žádné chemické látky ani hrubé hadříky.

Vážený zákazník, v případě že chybí některé části nebo jsou poškozené, označte je v montážních instrukcích a zašlete společně s reklamací. Pokud poškozená část bude na pevně smontována, nebude se na ni vztahovat reklamacie.

## DE

### Regeln der Möbelbenutzung:

1. Die Möbel sollten entsprechend ihrer Bestimmung verwendet werden.
2. Die Möbel sollten in trockenen, geschlossenen und gegen den schädlichen Witterungseinfluss sowie die direkte Wirkung der Sonnenstrahlen geschützten Räumen benutzt werden.
3. Die Möbel sollen von den tätigen Heizkörpern mindestens ein halbes Meter entfernt werden.
4. Es ist erforderlich, dass der Grund, wo die Möbel stehen, gut nivelliert und stabil ist.
5. Die Art und Weise der Montage, Anzahl der Bauteile und die Ausstattung, die für die Montage unentbehrlich ist, bestimmt die Infokarte, die sich in der Verpackung des jeweiligen Möbelstückes befindet. Es sei denn, die Möbel wurden nach dem Wunsch des Kunden im zusammengebauten Zustand geliefert. In einem solchen Fall werden die Montageanweisungen nicht hinzugefügt.
6. Auf der Oberfläche der Möbel darf man keine feuchten Gegenstände stellen.
7. Nach dem Zusammenbauen der Möbel sollte man die Tür an den Führungen richten.

### Wartung und Sauberhaltung:

1. Flächen aus Laminat und lackierte Oberflächen sind mit einem weichen Tuch zu reinigen.
2. Zur Pflege der Oberfläche sollten keine chemischen Mittel oder borstigen Wischtücher verwendet werden.

Sehr geehrter Kunde, sollte ein Bauteil fehlen oder geschädigt werden, kennzeichnen Sie dies bitte auf der Montageanweisung und zusammen mit dem Beschwerdebrief senden. Sollte das geschädigte Teil fest angebaut werden, wird die Beanstandung nicht anerkannt.

## EN

### Terms of use furniture:

1. Furniture should be used for their intended purpose.
2. Furniture should be used in dry, closed rooms, protected from an adverse weather and a direct sunlight.
3. Furniture should not be set at a distance of less than half a meter of active radiators.
4. The equal leveling is required and the need to set furniture on the stable base.
5. The information card, contained in the packaging of the given type of furniture defines the assembling method of furniture, quantity of components and accessories necessary for assembly. except when furniture were delivered assembled according to the customer wish. Assembly instructions are not attached to furniture in this case.
6. Wet objects should not be placed on surfaces of furniture.
7. Doors on tracks should be adjusted after assembling furniture.

### Maintenance and cleaning:

1. Surfaces made of the laminate and lacquered surfaces clean with a soft cloth.
2. Any chemicals or rough rubbers should not be used for the surfaces care.

Dear customer, if anything part is missing or damaged, mark it on the assembly instruction and sent to together with the claim, please. If the damaged item is permanently mounted, than the complaint will not be considered.

## SK

### Základy používania nábytku:

1. Nábytok používajte k určenému účelu.
2. Nábytok používajte v suchej, uzatvorenej a chránenej pred škodlivými poveternostnými vplyvmi miestnosti, chráňte pred priamym slnečným žiarením.
3. Nábytok by nemal byť postavený na menej než pol metra pred aktívnymi radiátormi.
4. Nábytok postavte na stabilný vyrovnaný povrch.
5. Návod na montáž nábytku počet súčasti a príslušenstva nevyhnutného k montáži, je uvedený na informačnom liste nachádzajúcom sa v obale určeného nábytku. V prípade, že na pranie zákazníka bol nábytok dodaný zmontovaný, nebude návod súčasťou balenia.
6. Na povrch nábytku, nepokladajte vlhke predmety.
7. Po zmontovaní nábytku nastavte dvere pomocou koľajnice.

### Údržba a čistenie:

1. Povrchy z lamina a lakované čistiť mäkkou handričkou.
2. Pre údržbu povrchu nepoužívajte žiadne chemické látky ani hrubé handričky.

Vážený zákazník, v prípade, že chýbajú niektoré časti, alebo sú poškodené, označte ich v montážnych instrukciách a pošlite spoločne s reklamáciou, pokiaľ poškodená časť bude napevno zmontovaná, nebude sa ňu reklamácia vzťahovať.

## RU

### Правила ухода за мебелью

1. Мебель необходимо использовать в соответствии с ее функциональным назначением.
2. Мебель должна эксплуатироваться в сухих закрытых и защищенных от воздействия атмосферных условий и прямых солнечных лучей помещениях.
3. мебель нельзя устанавливать ближе 50 см от отопительных приборов.
4. Требуется установка мебели по уровню на стабильной поверхности.
5. Способ монтажа мебели количество элементов необходимых для монтажа определяет инструкция находящаяся в упаковке данного типа мебели. В случае если мебель по желанию клиента была поставлена собранной инструкция монтажа не прилагается.
6. Нельзя ставить на мебель влажные предметы.
7. После монтажа мебели необходимо отрегулировать дверь на петлях.

### Рекомендации по уходу и очистке.

1. Поверхности из ламината и покрытые лаком очищать мягкой тканью.
2. Для ухода за поверхностью не использовать никаких химических средств или шероховатых тряпок.

Уважаемы Клиент в случае если не хватает какого-нибудь элемента или он поврежден просим обозначить его на инструкции монтажа и отправить нам в месте с претензией. Если поврежденный элемент будет установлен-претензия не будет признана.

## FR

### Règles d'utilisation du mobilier :

1. Le mobilier doit être utilisé conformément à sa destination.
2. Le mobilier doit être utilisé dans un endroit sec, fermé et protégé des influences atmosphériques néfastes et la lumière directe du soleil.
3. Les meubles ne doivent pas être placés à moins d'un demi-mètre de radiateurs actifs.
4. Une mise à niveau est nécessaire, il faut placer le meuble sur une surface stable.
5. La méthode de montage des meubles, le nombre d'éléments et d'accessoires nécessaires au montage sont définis dans la fiche d'information incluse dans l'emballage d'un type de meuble donné, sauf si les meubles ont été livrés montés conformément à la demande du client.  
Dans ce cas, les notices de montage ne sont pas fournies avec les meubles.
6. Ne posez pas d'objets humides sur les surfaces des meubles.
7. Après avoir monté le meuble, ajustez les portes sur les guides.

### Entretien et nettoyage :

1. Les surfaces stratifiées et vernies doivent être nettoyées avec un chiffon doux.
2. Pour l'entretien des surfaces, n'utilisez pas de produits chimiques ou des chiffons abrasifs.

Cher client, si une pièce est manquante ou endommagée, veuillez l'indiquer dans la notice de montage et envoyer avec la réclamation. Si l'élément défectueux est installé de façon permanente, la réclamation ne sera pas acceptée.

## SE

### Regler för möblernas underhåll och rengöring:

1. Möblerna ska användas för sitt avsedda ändamål.
2. Möblerna ska användas i torra, slutna utrymmesom är skyddade mot skadlig atmosfärisk påverkan och direkt solstrålning.
3. Möblerna bör inte placeras på ett avstånd som är mindre än en halv meter från värmeelement.
4. Det krävs en jämn yta (med samma nivå), och placering av möblerna på ett stabilt underlag.
5. Monterings sätt av möbler, antal komponenter (delar) och tillbehör som är nödvändiga för montage anges på informationskort som finns i förpackning för enskild möbeltyp. Om möblerna inte har levererats monterade på kundens begäran. I sådant fall är monteringsanvisningen inte bifogad möblerna.
6. På möblernas ytor bör man inte ställa våta föremål.
7. Efter möblernas montering måste skåpdörrarjusteras på skenorna.

### Möblernas underhåll och rengöring:

1. Ytor av laminat samt målade ytor ska rengöras med en mjuk trasa.
2. För ytans underhåll får man inte använda några kemikaliskamedel eller slipdyna.

Bästa kund, om det saknas någon del, eller om den är trasig, vänligen markera det på installationsinstruktionen och skickadett tillsammans med ansökan. Om den skadade delen kommer att användas som monterad permanent, kommer klagomålet inte att beaktas.

## HR

### Način uporabe namještaja

1. Namještaj koristiti sukladno namjeni.
2. Namještaj mora se koristiti u suhim i zatvorenim prostorijama osiguranim od štetnih vremenskih uvjeta i izravnog sunčevog zračenja.
3. Namještaj ne može se stavljati na razmaku od najmanje 50 cm od uključenih grejačkih uređaja.
4. Površina na koju stavljate namještaj mora biti nivelirana i stabilna.
5. Način montaže, broj dijelova i akcesorija potrebnih za montažu određuju upute za montažu namještaja koje se nalazi unutar ambalaže. Ako se kupcu namještaj isporučuje montiran, upute nisu uključene.
6. Ne stavljati vlažne predmete na površinu namještaja.
7. Nakon montaže namještaja regulirati vrata na vodilicama.

### Održavanje i čišćenje:

1. Površine od laminata i lakirane čistiti mekanom krpom.
2. Za održavanje površina ne koristiti kemijska sredstva ili abrazivne krpe.

Poštovani kupci, u slučaju nedostatka ili oštećenja bilo kojeg dijela, označite ovaj element u uputama za montažu i pošalite zajedno s reklamacijom. ako je oštećeni element trajno montiran, reklamacija neće se razmatrati.

## SRB

### Način korišćenja nameštaja

1. Nameštaj treba da bude korišćen u skladu sa namenom.
2. Nameštaj mora da bude korišćen u suvim i zatvorenim prostorijama zaštićenim od nepovoljnih vremenskih uslova i direktne sunčeve svetlosti.
3. Nameštaj ne može da bude postavljen na udaljenosti od najmanje 50 cm od uključenih uređaja za grejanje.
4. Nameštaj mora da bude postavljen na ravnu i stabilnu podlogu.
5. Način postavljanja, broj delova i akcesorija neophodnih za postavljanje definiše uputstvo za postavljanje nameštaja koje se nalazi unutra pakiranja. Ovo uputstvo se ne odnosi na nameštaj koji je prema želji kupca isporučen u gotovom stanju. u ovom slučaju uputstvo nije uključeno u set nameštaja.
6. Nemojte stavljati vlažne predmete na površinu nameštaja.
7. Nakon postavljanja nameštaja podesite vrata na vodilicama.

### Održavanje i čišćenje:

1. Površine od laminata i lakirane čistite mekanom tkaninom.
2. Za održavanje površina nemojte koristiti hemijska sredstva ili abrazivne krpe.

Postovani kupci, u slučaju nedostatka ili oštećenja bilo kojeg dela, označite ovaj element u uputstvu za postavljanje i pošalite zajedno sa reklamacijom. Ako je oštećen element trajno postavljen, reklamacija neće biti razmatrana.

## HU

### Használati útmutató

1. A bútortokat rendeltetésüknek megfelelően kell használni.
2. A bútortokat az időjárás körülményeitől védett, zárt, szárazhelyiségekben kell használni, ahol nincsenek kitéve a napsugárak közvetlen hatásának.
3. A bútortokat a működő fűtőberendezésekhez ne helyezzük fel méternél kisebb távolságra.
4. Fontos, hogy a bútort stabil alapzaton, szintbe állítva használják.
5. A bútórészegység összeállításához szükséges ismereteket, az elemek mennyiségét, és az összeállításához szükséges tartozékok listáját az összeszerelési útmutató tartalmazza, mely az adott típusú bútórészegység csomagolásában található. Abban az esetben, ha a bútórészegység megrendelésénél megrendelték az összeszerelési útmutatót, a bútórészegység mellékelve az összeszerelési útmutatót.
6. A bútórészegység felületére ne helyezzünk nedves tárgyakat.
7. A bútórészegység összeállítását követően be kell állítani az ajtókat a kivetőpántok segítségével.

### Ápolás és tisztítás

1. A laminált és lakkozott felületeket puha ruhával tisztítsuk.
2. A felületek ápolásához ne használjunk semmilyen vegyszert, vagy durva törölkendőt.

Tisztelt Vésario, ha valamelyik bútorelem hiányozna, vagy hibásan kerülne átadásra, kérjük jelölje azt be az összeszerelési útmutatóban, és a reklamációval együtt küldje el részünkre. Amennyiben a hibás elem eredeti rendeltetési helyére beszerelésre kerül, a reklamációt nem áll módunkban elfogadni.

## NZ

### Gebruiksregels voor meubels:

1. Meubels moeten worden gebruikt waarvoor ze bedoeld zijn.
2. Meubels moeten worden gebruikt in een droge, gesloten ruimte die bescherming biedt tegen schadelijke weersinvloeden en direct zonlicht.
3. Plaats de meubels niet binnen een halve meter afstand tot een werkende radiator.
4. Meubels moeten waterpas staan op een stabiele ondergrond.
5. De montage methode en het aantal benodigde onderdelen en accessoires voor de montage blijken uit het informatieblad in de verpakking. Dit geldt niet wanneer de meubels naar wens van de klant gemonteerd zijn geleverd. In dat geval ontvangt u geen handleiding.
6. Plaats geen vochtige voorwerpen op de meubels.
7. Na montage van de meubels moeten de deuren op de geleiders worden afgesteld.

### Onderhoud en reiniging:

1. Oppervlakken van laminaat en met een laklaag afnemen met een zachte doek.
2. Gebruik voor het onderhoud van de oppervlakken geen chemische middelen of ruwe doeken.

Indien er een onderdeel ontbreekt of beschadigd is, geef dit dan aan op de montagehandleiding en stuur deze samen met uw klacht op. Als het beschadigde onderdeel permanent wordt gemonteerd, wordt de klacht niet ingewilligd.