

# HAGAR

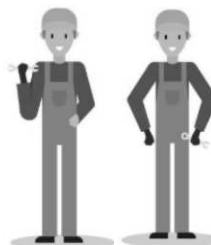

30min

1/8

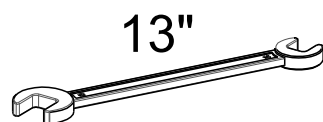
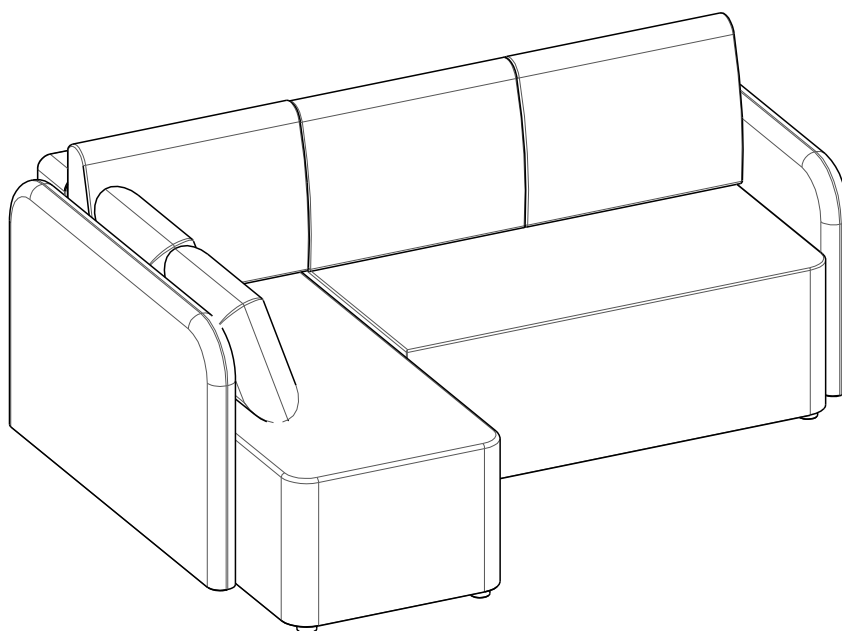
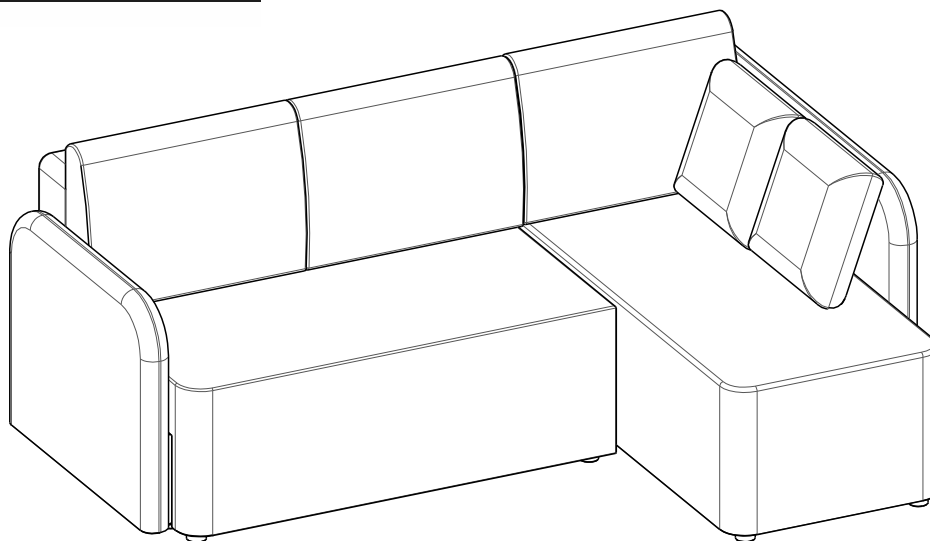
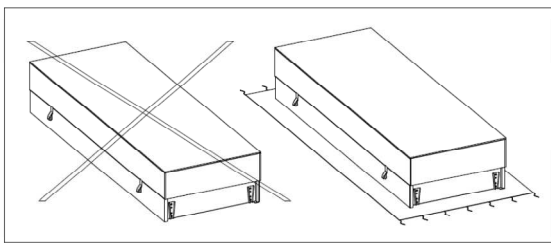

O	1x
S	1x
B	1x
L	1x
P1	3x
P2	2x

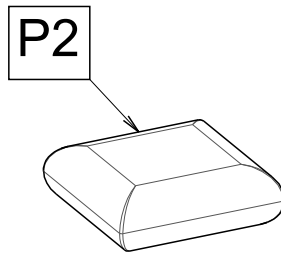
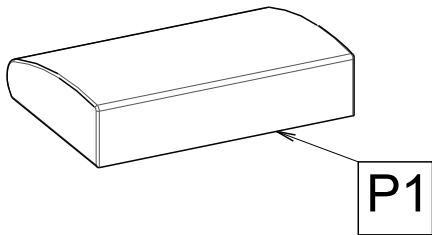

## PRAVÁ

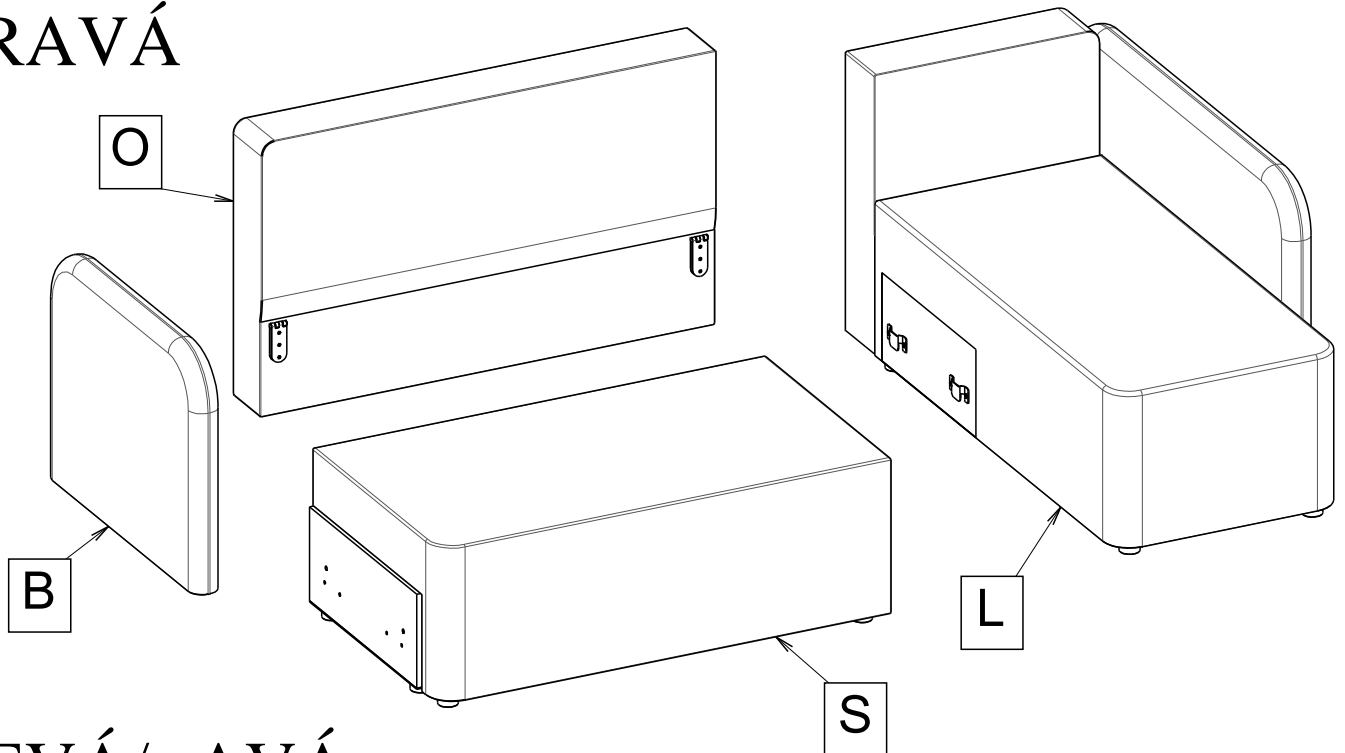

## LEVÁ/ AVÁ

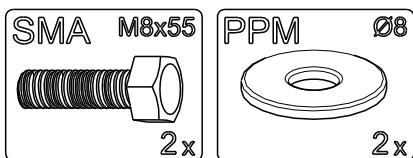
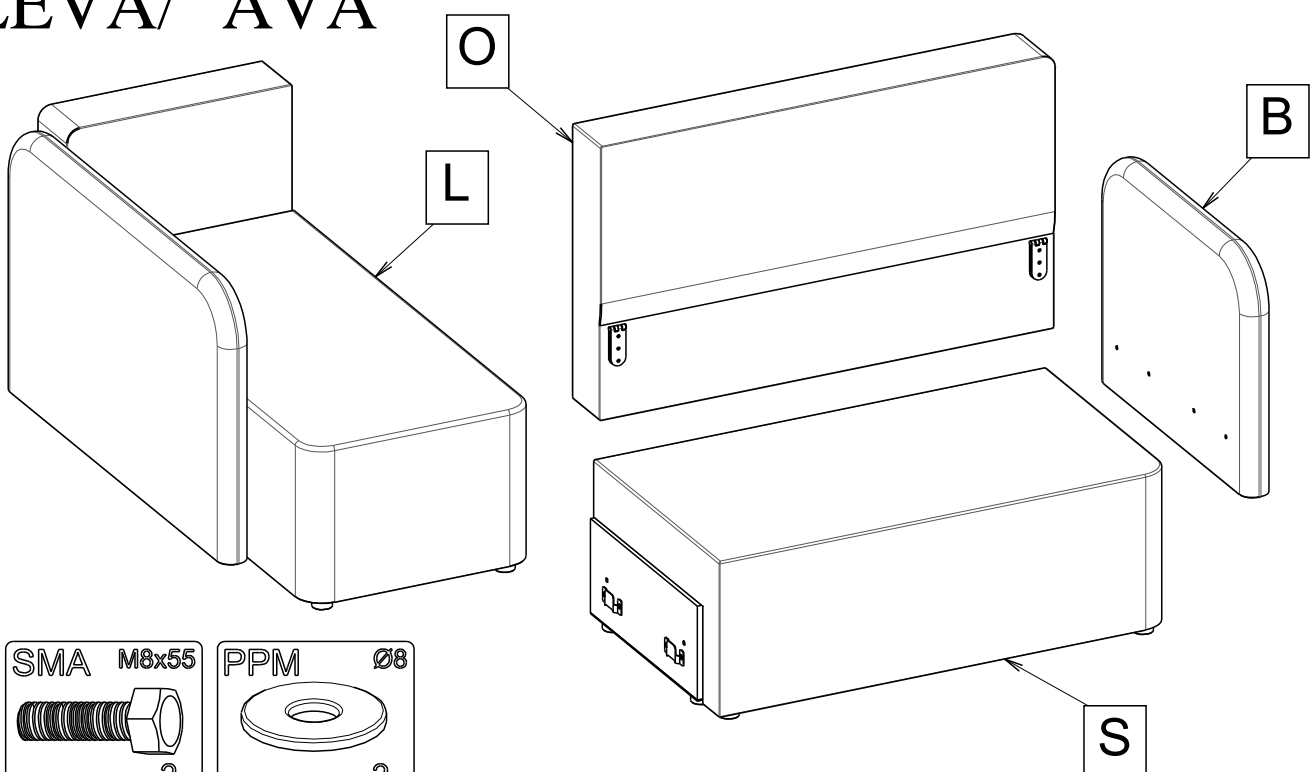

# LEVÁ/ AVÁ

1

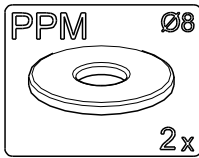
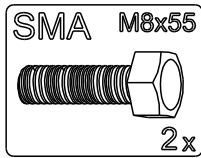

2x

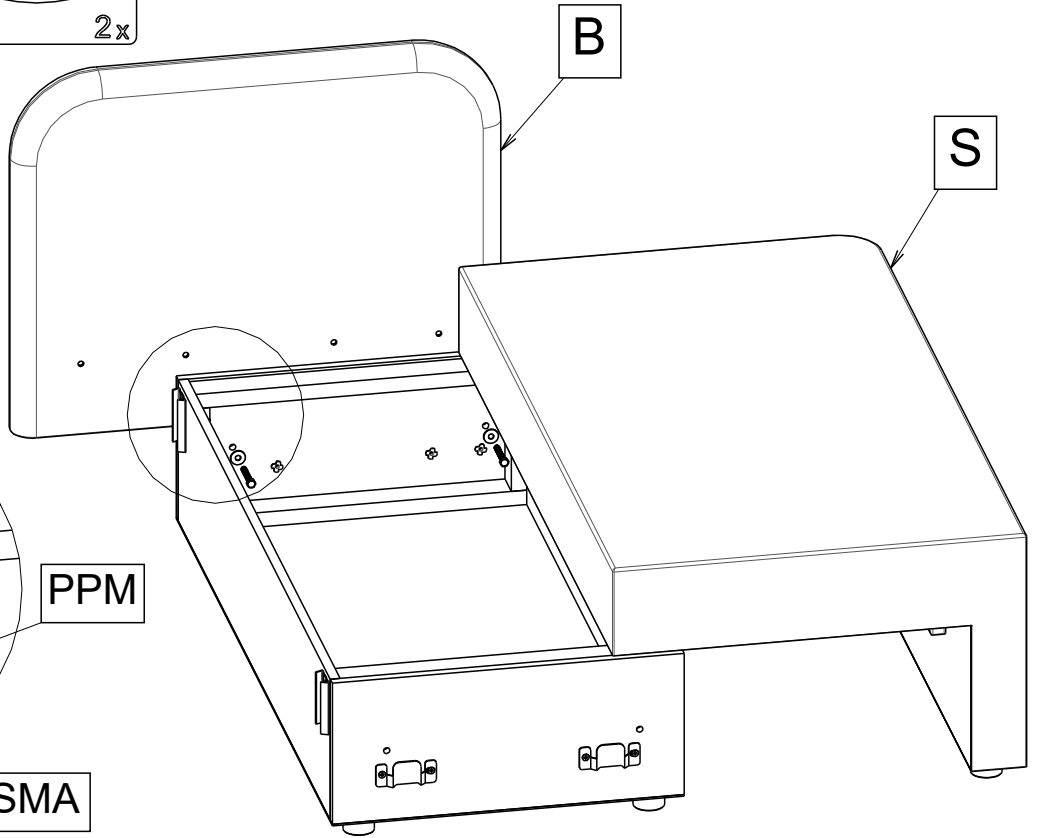
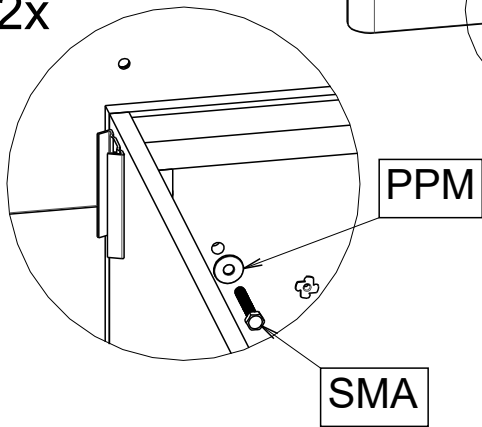

2

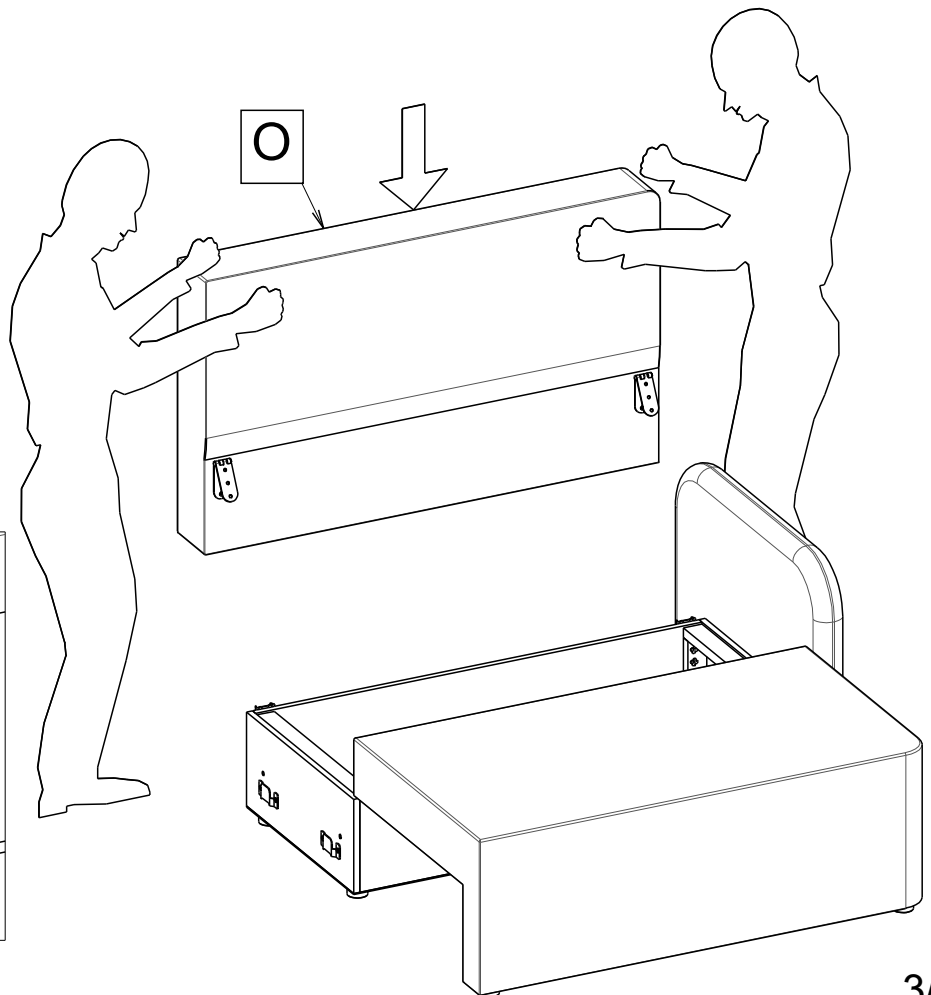
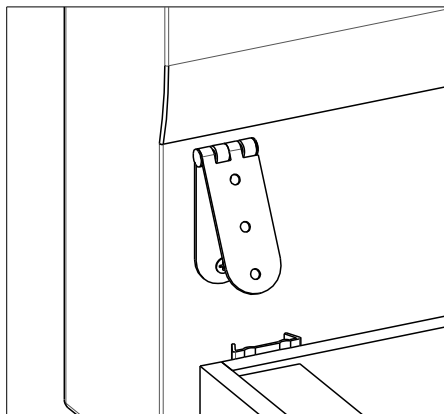
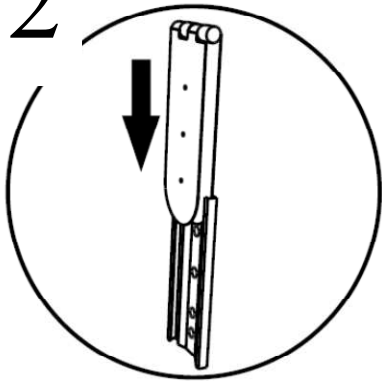

3

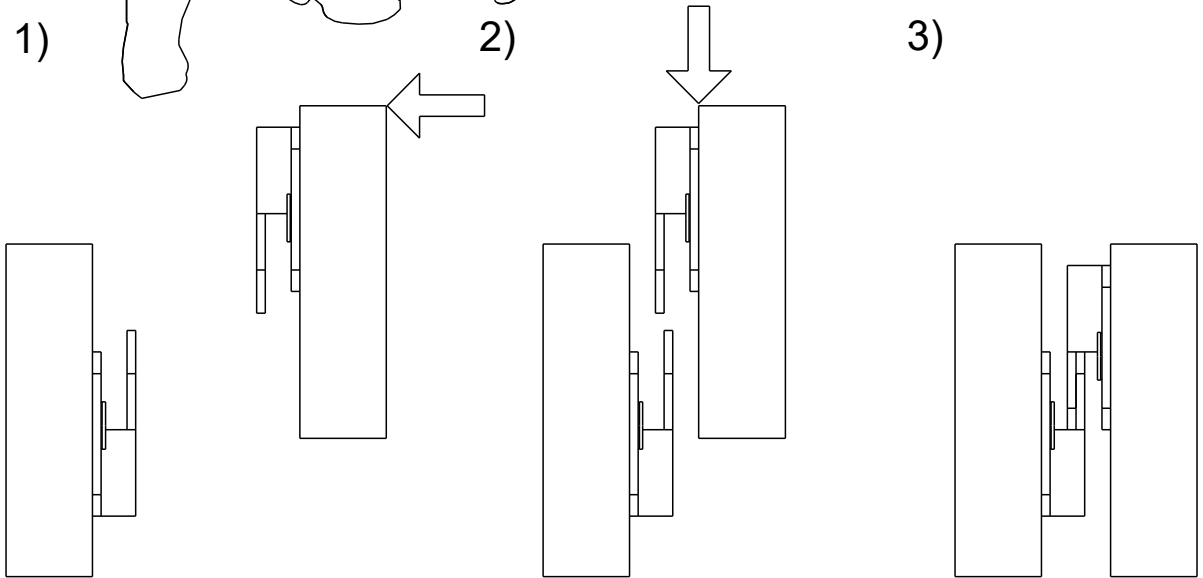
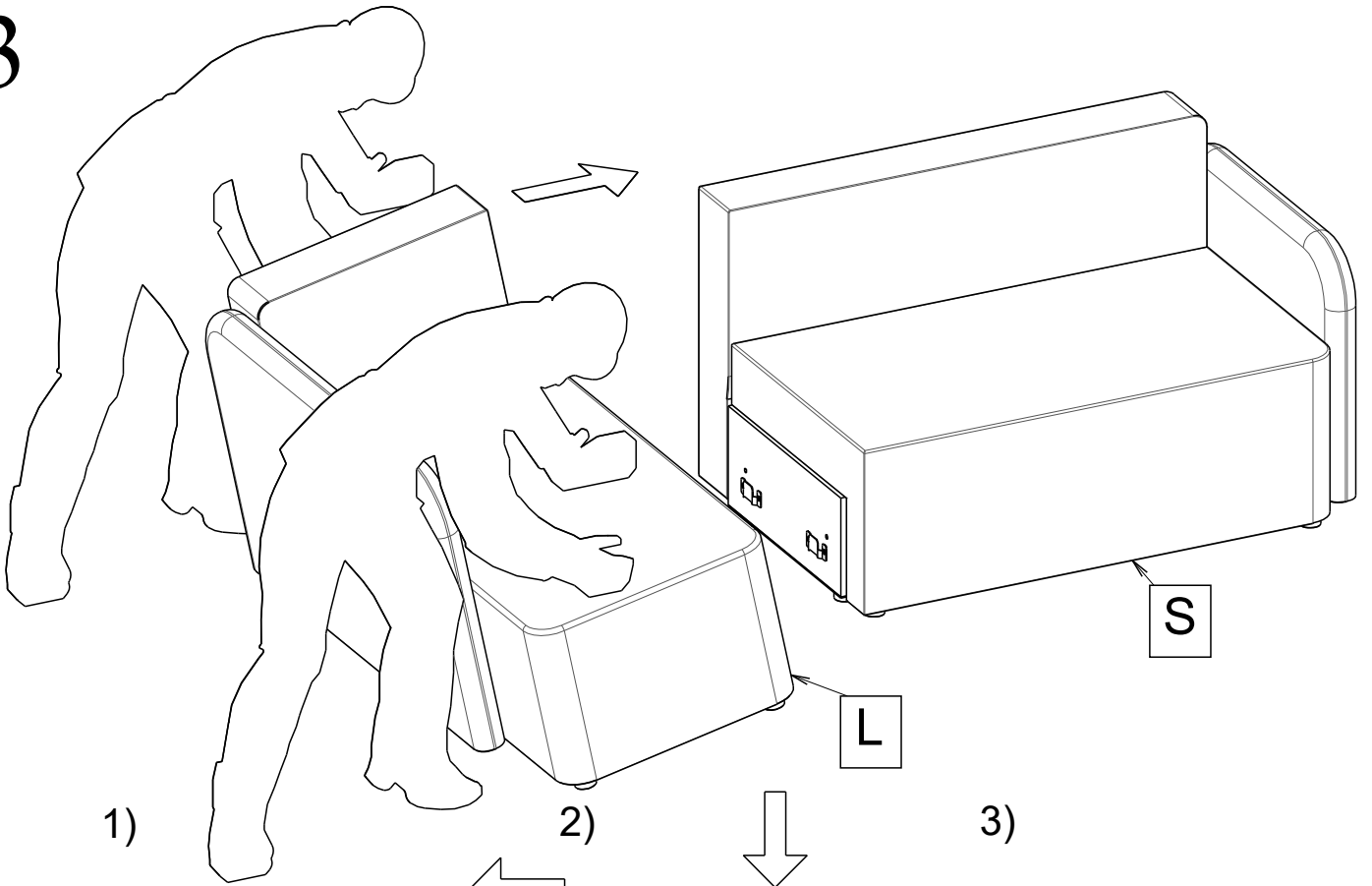

4

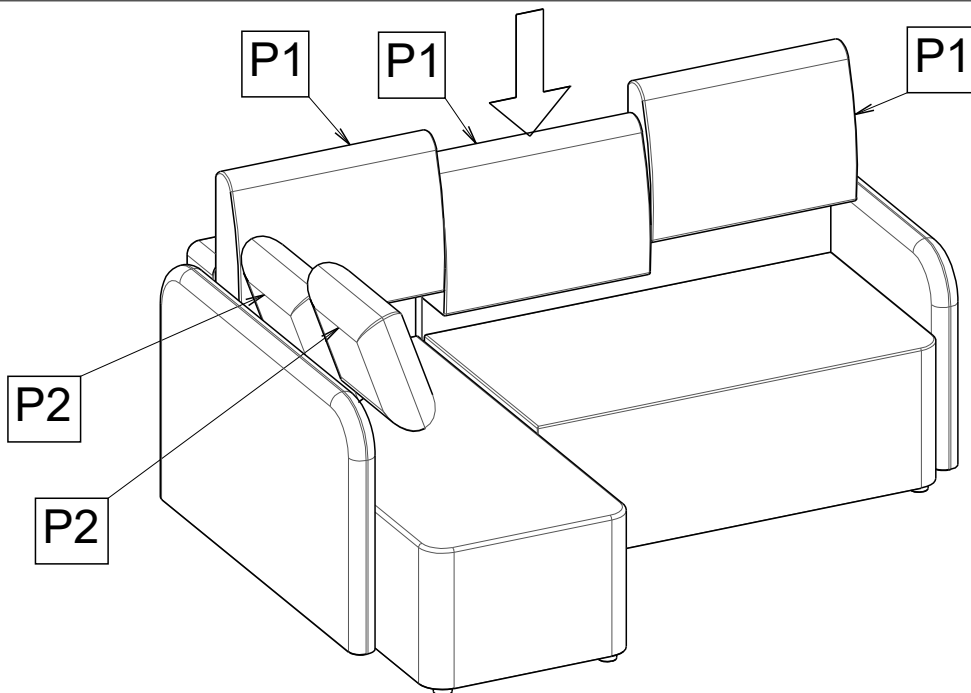

# PRAVÁ

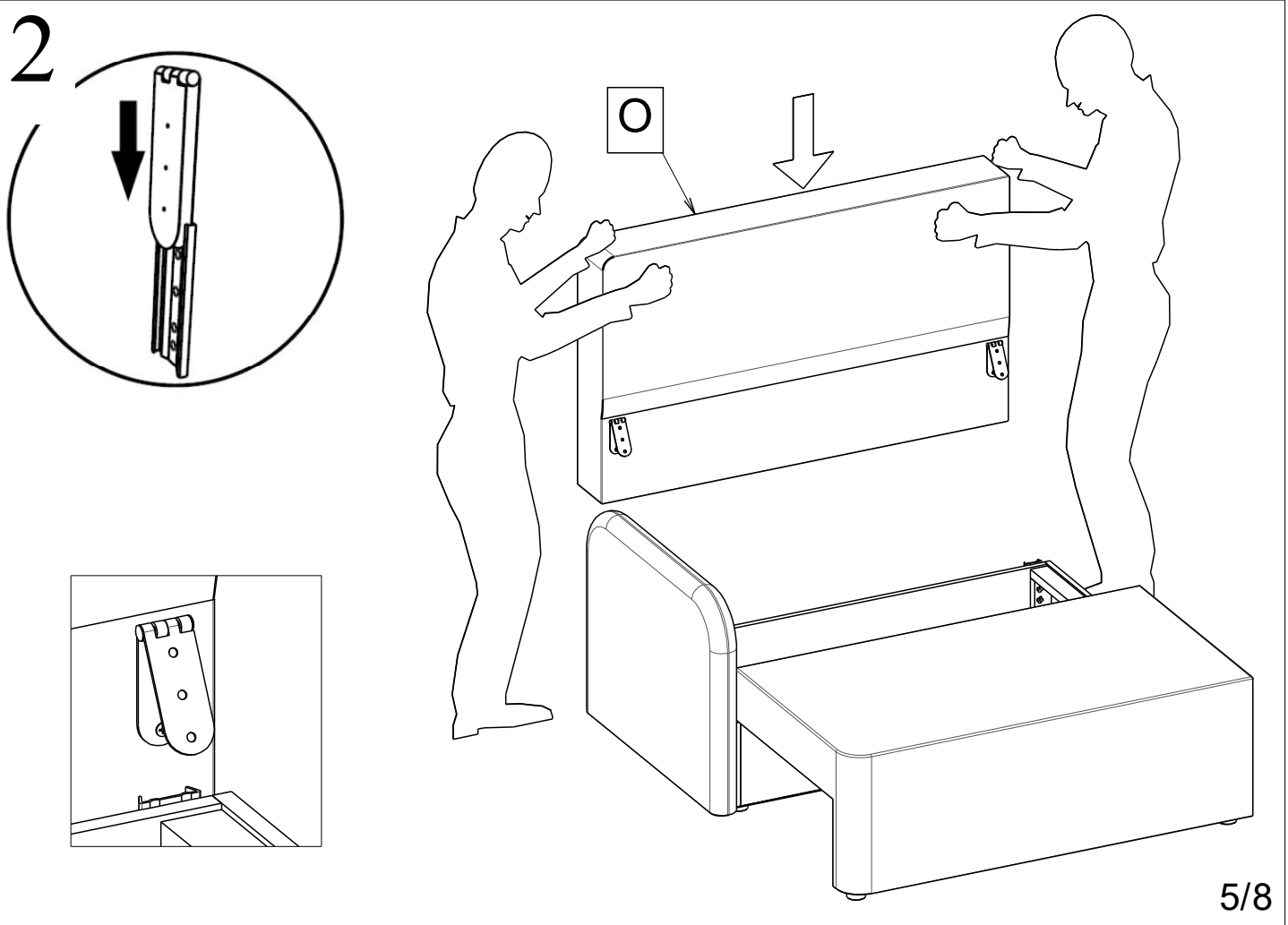
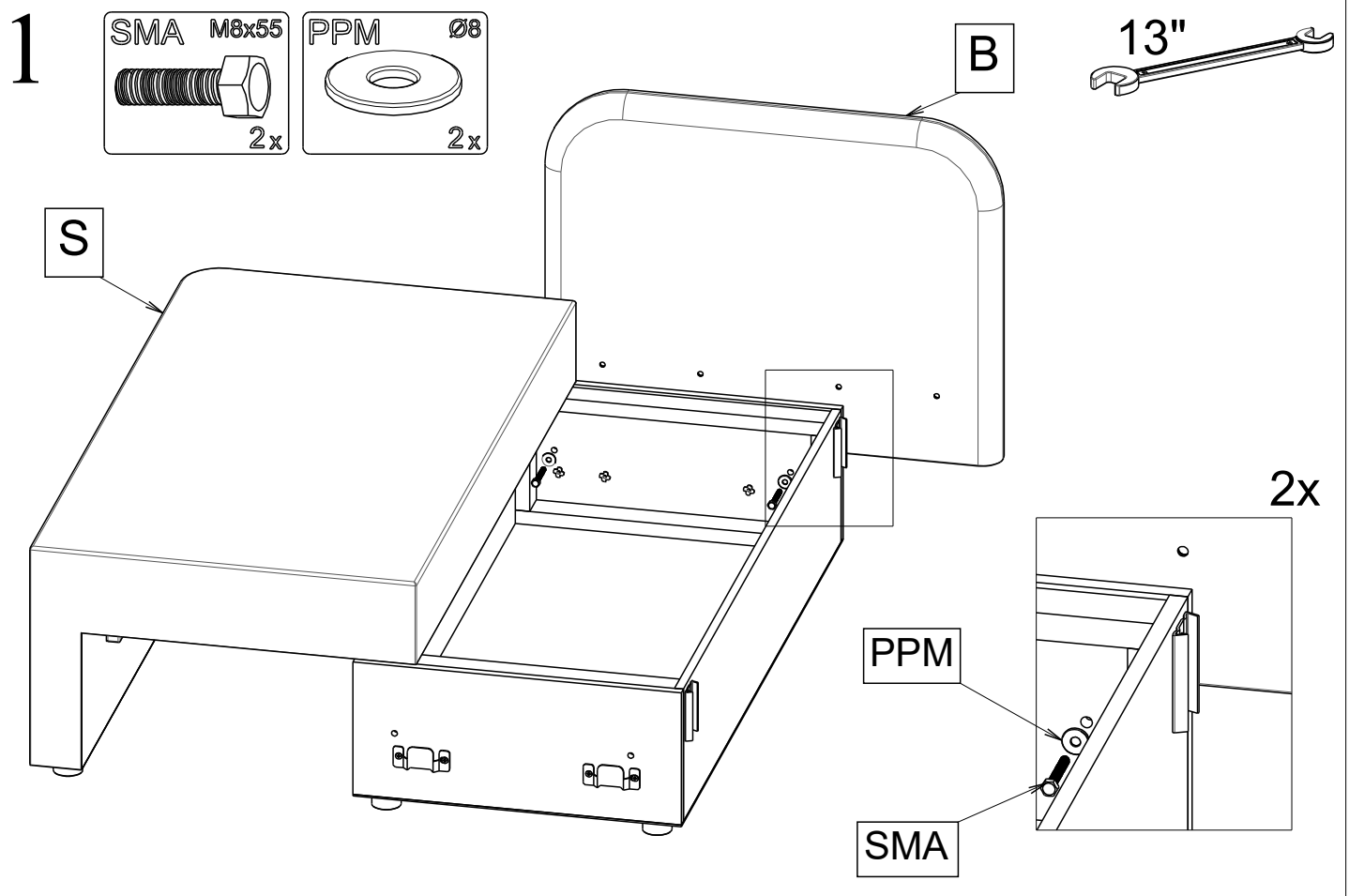

3

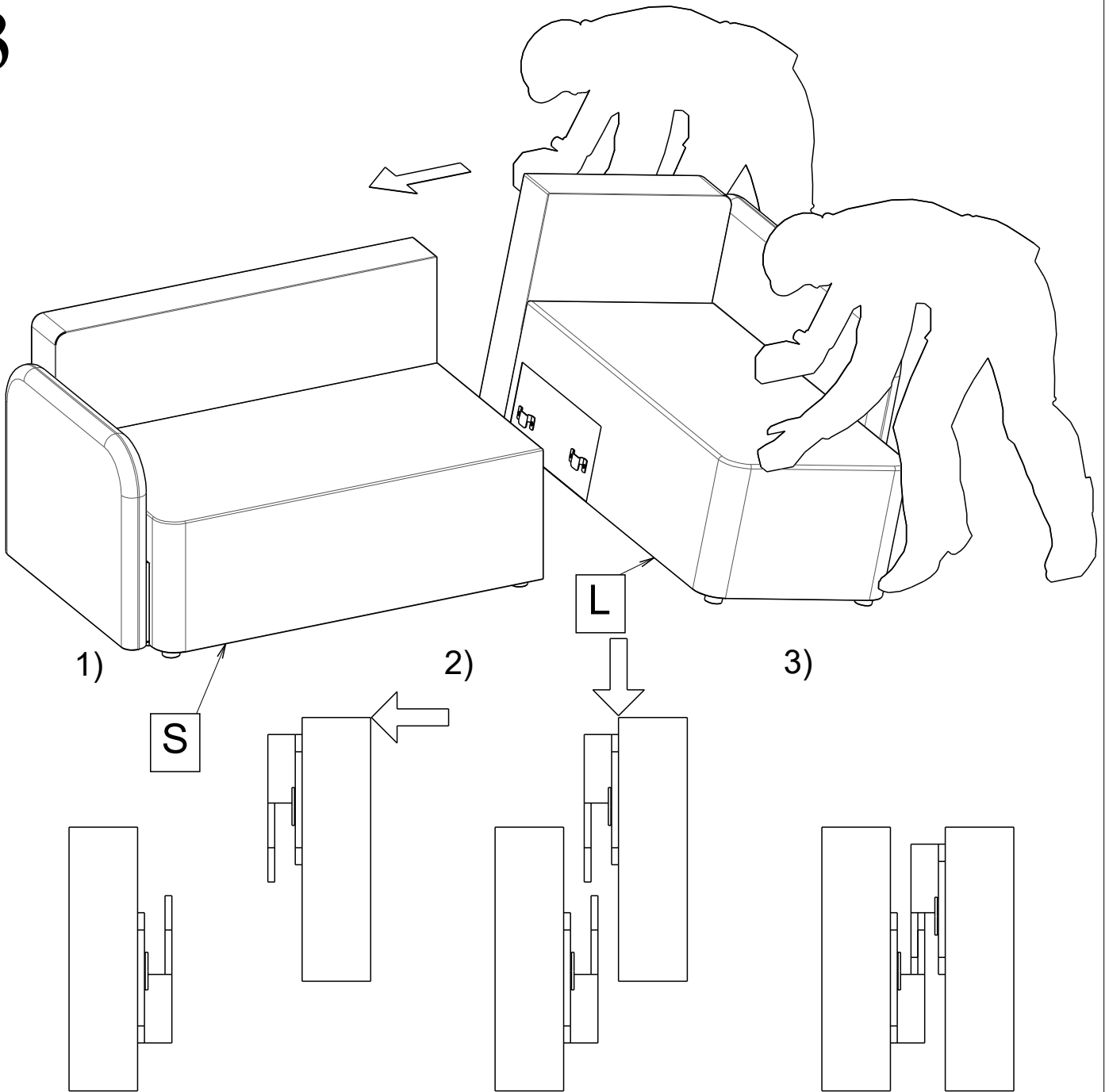

4

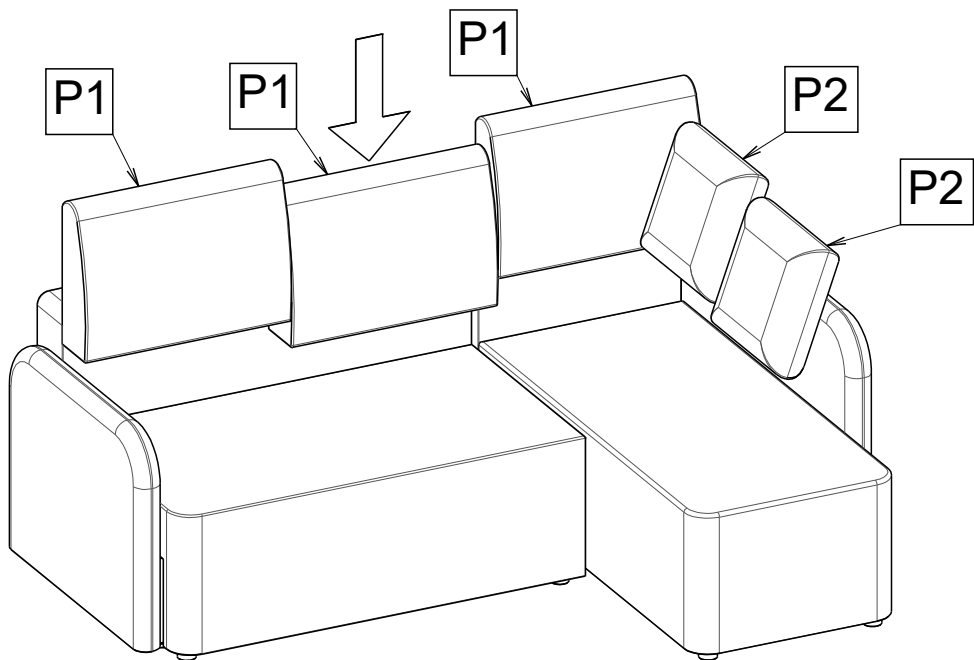

# A

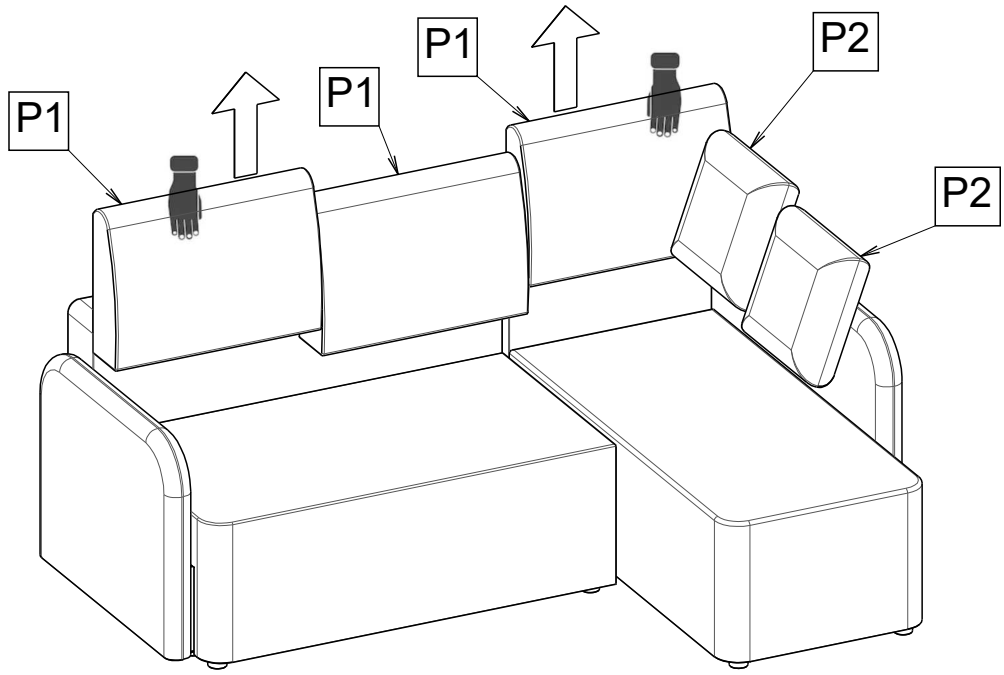

# B

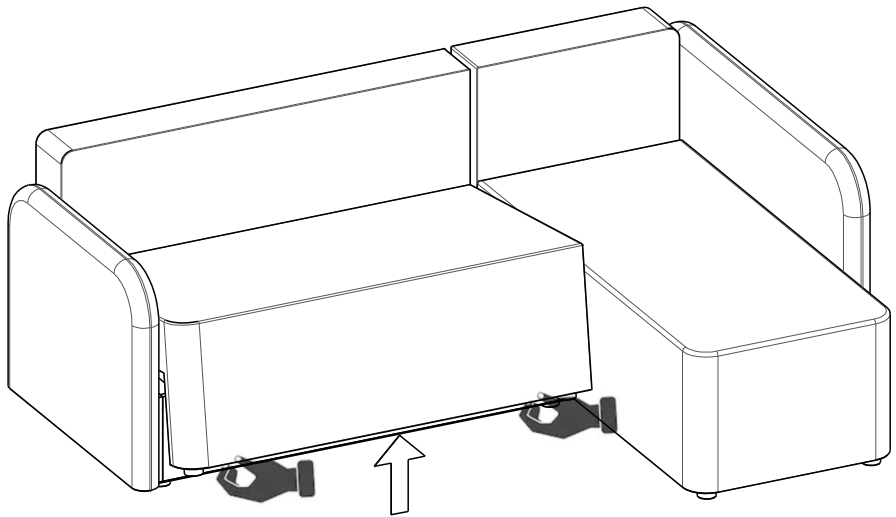
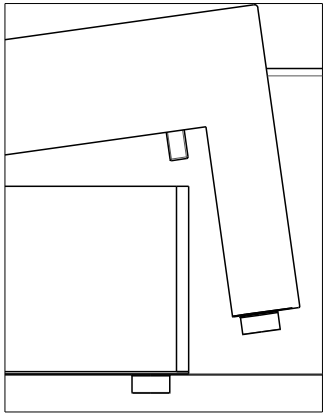

# C

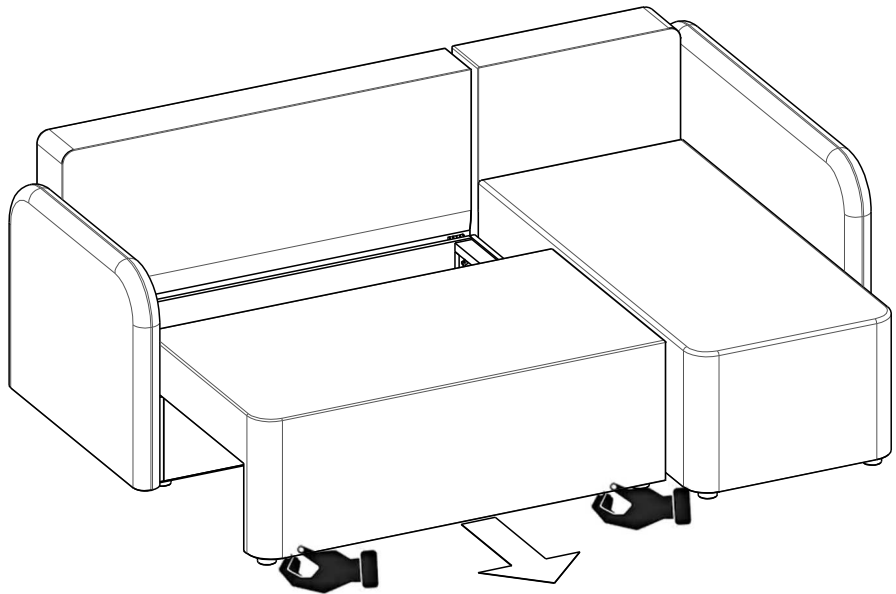
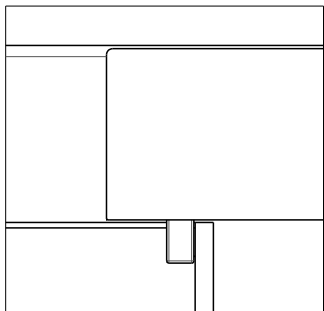

D

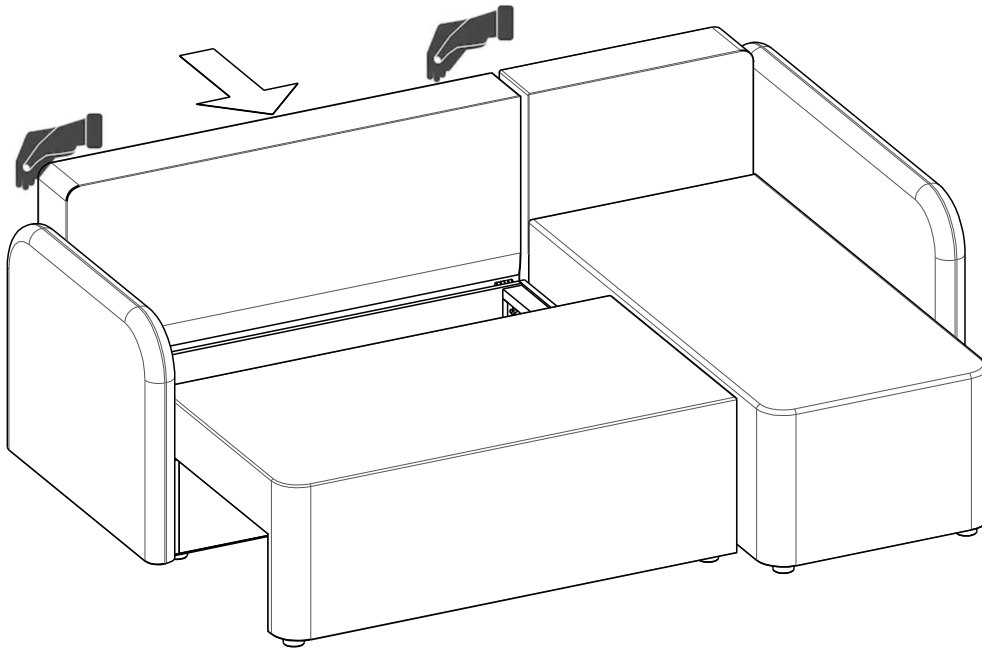

E

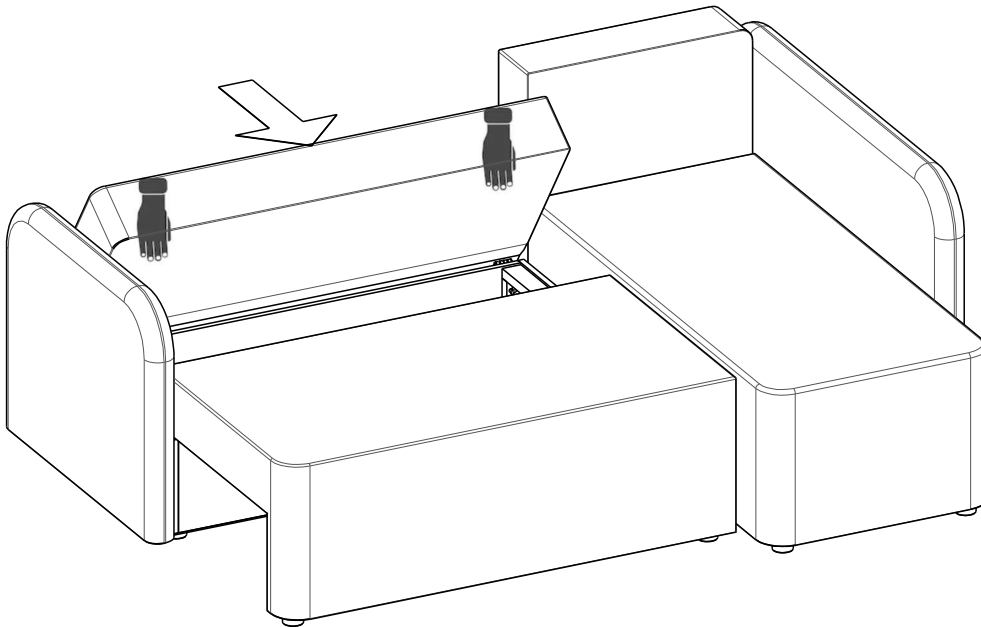

F

