

# KONSO

LKZ 42416 / 75033

# 21

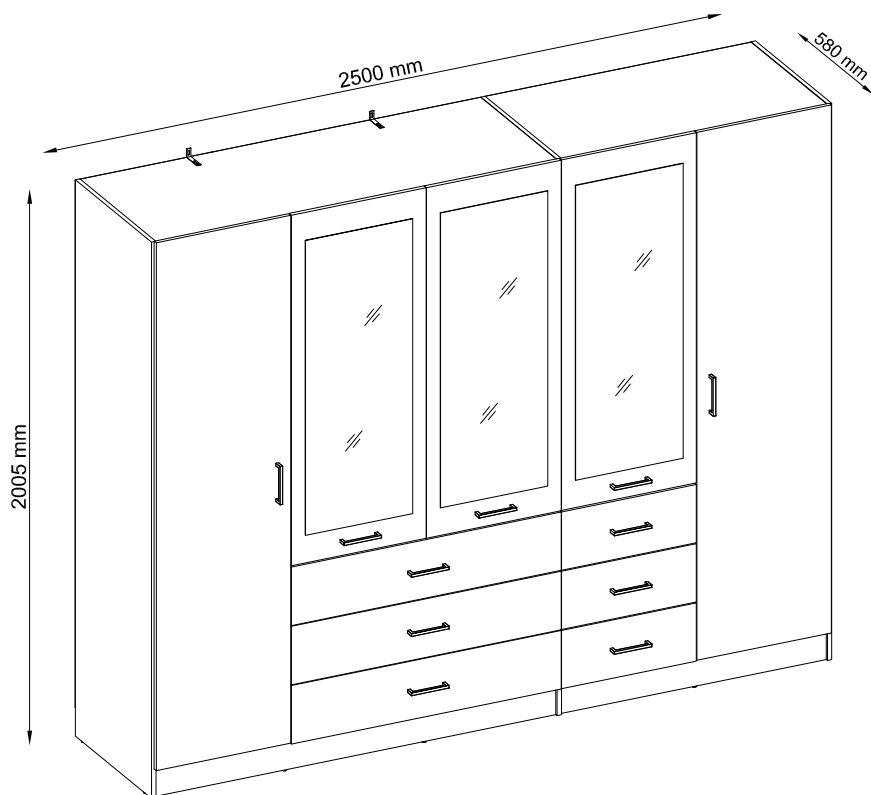

**D** **Montageanleitung**  
Kleiderschrank >Konso<

**FR** **Notice de montage**  
Armoire >Konso<

**NL** **Handleiding voor de montage**  
Kast >Konso<

**CZ** **Montážní návod**  
Kabinet >Konso<

**HU** **Szerelési útmutató**  
Szekrény >Konso<

**TR** **Montaj talinati**  
Dolap >Konso<

**GB** **Assembly instructions**  
Wardrobe >Konso<

**IT** **Intruzioni di montaggio**  
Armadio >Konso<

**PL** **Instrukcja montażu**  
Szafa >Konso<

**SK** **Návod na montáž**  
Skriňa >Konso<

**RO** **Instructiuni de montaj**  
Cabinet >Konso<

**RU** **Инструкция по монтажу**  
Шкаф >Konso<

**SRB** **Упутства за инсталацију**  
Гардеробу >Konso<

**HR** **Upute za instalaciju**  
Ormar >Konso<

**SL** **Návod na montaž**  
Kabinet >Konso<

**LT** **Surinkimo instrukcijos**  
Kabinetas >Konso<

**LV** **Montāžas instrukcija**  
Ministru kabinets >Konso<

**EE** **Kokkupaneku juhised**  
Kabinet >Konso<

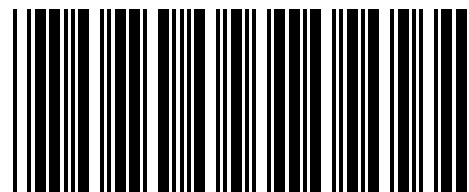
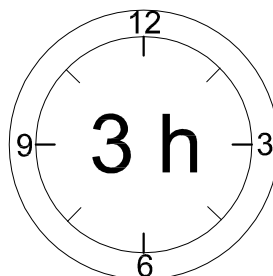
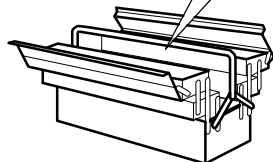
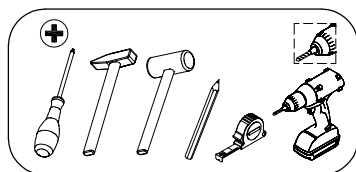
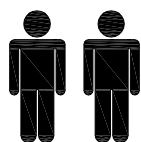

\* 2 5 2 7 2 9 \*

**D-**Ziehen Sie alle Schrauben sowie tragende Verbindungsteile nach ca. 5 Wochen nach, um einedauerhafte Standsicherheit zu gewährleisten.

**GB-**After approx. 5 weeks, tighten all screws and load-bearing connecting parts to ensure permanent stability.

**FR-**Resserrez toutes les vis ainsi que les pièces de fixation au bout d'environ 5 semaines pour garantir une sécurité de fixation durable.

**IT-** Ristringere tutte le viti e giunture dopo ca. 5 settimane, al fine di garantire una durevole solidità.

**NL-**Draai alle schroeven en ook dragende verbindingstukken na ca. 5 weken nog eens vast, zodateen continue stabiliteit wordt gegarandeerd.

**PL-**Prosimy po ok. 5 tygodniach dokręcić wszystkie śruby i elementy łączeniowe. Zagwarantuje to Państwu trwałość i stabilność połączeń.

**CZ-** Dotáhněte všechny šrouby a nosné spojovací díly přibližně po 5 týdnech, aby se zaručila trvalá stabilita.

**SK-**Po cca 5 týždňoch dotiahnite skrutky, aby bola zaručená ich trvalá stabilita.

**HU-**Húzza utána - kb. 5 hét múlva - az összes csavart és a teherhordó összekötő-alkatrészeket abiztonság érdekében.

**RO-**Pentru a asigura o stabilitate de durată, strângeți după cca. 5 săptămâni toate șuruburile, precumși toate elementele portante de legătură.

**TR-**Tüm vida ve taşıyıcı bağlantı parçalarını kalıcı bir duruş güvenliğini sağlamak için yaklaşık 5 haftasonra tekrar sıkınız.

**RU -** Подкрутите все болты, а также несущие соединительные детали припл. через 5 недель для обеспечения устойчивости в течение длительного времени.

**SRB -** Molim vas posle akrokca. 5 nedelja zategnite sve šrafove i pričvršćivače. To ће вам гарантовати трајност и стабилност веза.

**HR -** Molim vas, nakon cca. 5 tjedana zategnite sve vijke i pričvršćivače. To će vam jamčiti trajnost i stabilnost priključaka.

**SL -** Pýtame sa po cca. 5 týždňov utiahnite všetky skrutky a upevňovacie prvky. To zaručuje trvanlivosť a stabilitu spojov.

**LT -** Mes prašome po maždaug. 5 savaites priveržkite visus varžtus ir tvirtinimo detales. Taip užtikrinamas jungčių patvarumas ir stabilumas.

**LV -** Mēs lūdzam pēc apm. 5 nedēļas, pievelciet visas skrūves un stiprinājumus. Tas garantē savienojumu izturību un stabilitāti.

**EE -** Küsime pärast ca. 5 nädalat, pingutage kõiki kruvisid ja kinnitusi. See tagab ühenduste vastupidavuse ja stabiilsuse.

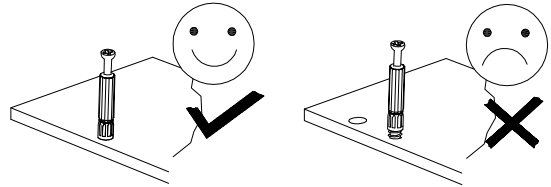

**D** Bitte nur mit einem Staubtuch oder leicht feuchtem Lappen reinigen. Keine scheuernden Putzmittel verwenden.

**GB** Please only clean with a duster or a damp cloth. Do not use any abrasive cleaners.

**FR** Veuillez nettoyer uniquement avec un chiffon à poussière ou un chiffon légèrement humide. N'avez pas utiliser de détergent abrasif.

**IT** Si raccomanda di pulire solo con un panno per la polvere o uno strofinaccio umido. Non utilizzare detergenti abrasivi.

**NL** Reinig alleen met een stofdoek of een lichtjes vochtige doek. Gebruik geen schurende poetsmiddelen.

**PL** Czyszczenie należy wykonać wyłącznie za pomocą ściereczki lub lekko nawilżonego ręcznika. Nie stosować środków czyszczących do szorowania.

**CZ** Čistěte prosím jen prachovkou nebo lehce navlhčeným hadrem. Nepoužívejte drhňoucí čisticí prostředky.

**SK** Na čistenie používajte len prachovku alebo zľahka navlhčenú utierku. Nepoužívajte žiadne drhňúce čistiace prostriedky.

**HU** Kérjük, csak portórló kendővel vagy enyhén nedves ronggyal tisztítsa. Ne használjon dörzshatású tisztítószert.

**RO** Vă rugăm să utilizați la curățare exclusiv o cârpă de șters praful sau o cârpă ușor umezită. Nu utilizați substanțe de curățat abrazive.

**TR** Lütfen sadece bir toz bezıyla veya hafif nemli yumuşak bir bezle siliniz. Aşındırıcı temizlik malze-meleri kullanmayınız.

**RU** Для чистки используйте, пожалуйста, тряпку для пыли или слегка влажную ветошь. Не использовать абразивные чистящие средства.

**SBR** Чишћење треба обавити само крпом или благо влажним пешкиром. Немојте користити средство за чишћење рибања.

**HR** Čišćenje treba obaviti samo krpom ili blago navlaženim ručnikom. Ne koristite sredstva za čišćenje ribanja.

**SL** Čistenie by sa malo vykonávať len handričkou alebo ľahko navlhčeným uterákom. Nepoužívajte čistiace prostriedky na drhnutie.

**LT** Valyti galima tik šluoste arba lengvai sudrėkintu rankšluosčiu. Nenaudokite šveičiamųjų valiklių.

**LV** Tīršana jāveic tikai ar drānu vai viegli samitrinātu dvieli. Neizmantojiet tīršanas līdzekļus.

**EE** Puhastada tohib ainult lapiga või kergelt niisutatud rätikuga. Ärge kasutage puhastusvahendeid.

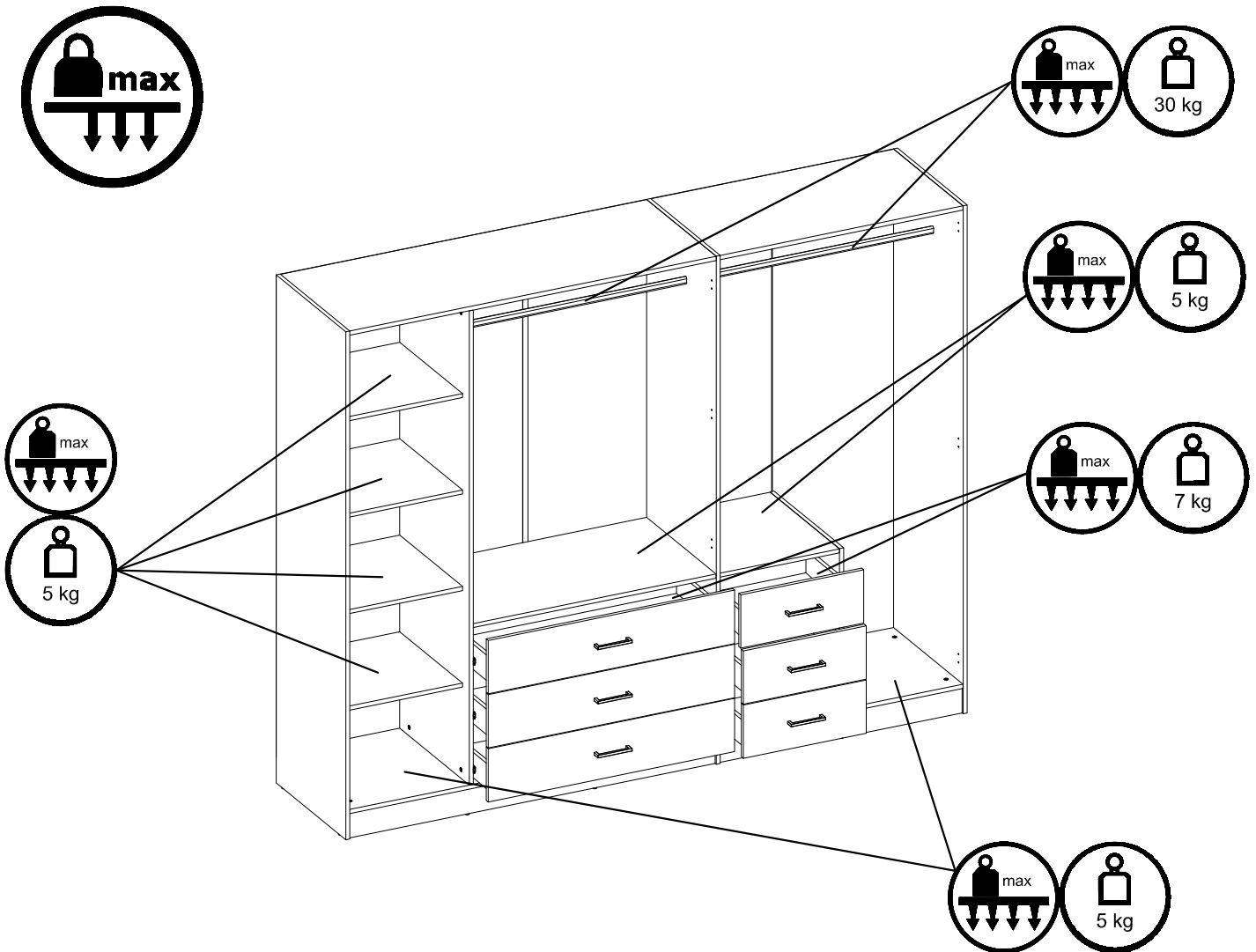
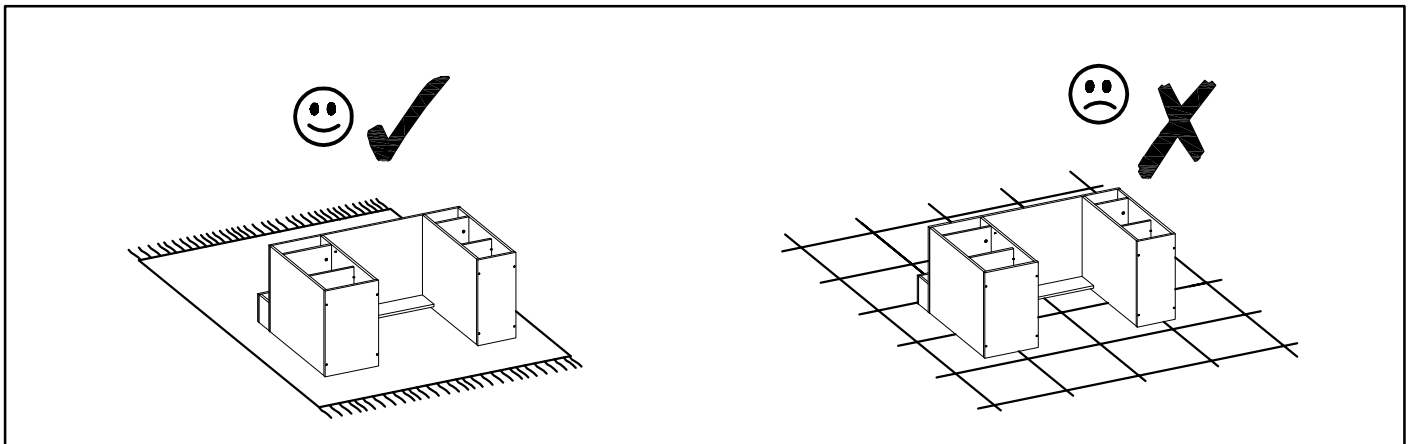
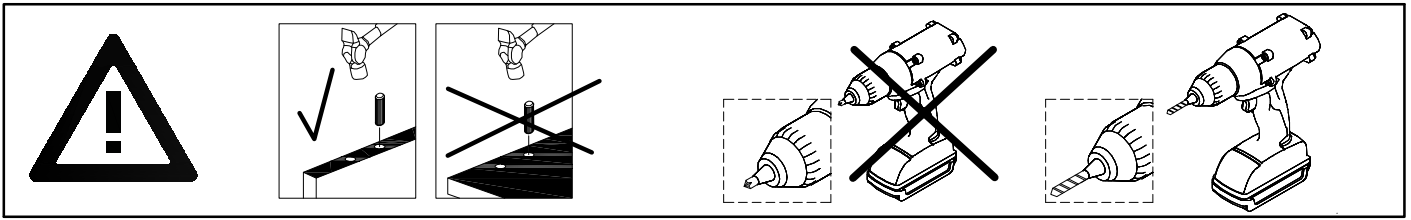
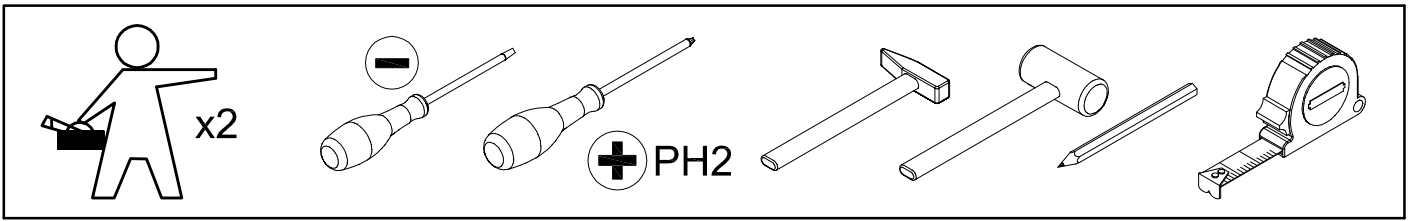

# Service · Assistenza · Dienstverlening · Serwis Servis · Szerviz · Сервисная служба · Сервис · Serwis · Servis

Name · Nom · Nome · Naam ·  
 Nazwa · Jméno · Názov · Név ·  
 Denimire · Isim · Название

KONSO

Тур · Туре · Тір · Тірус · Тіро ·  
 Тип

21

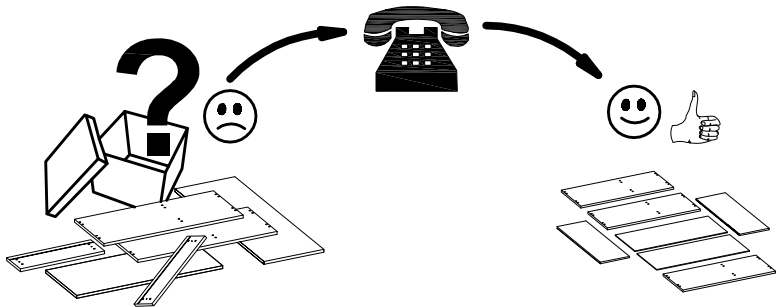
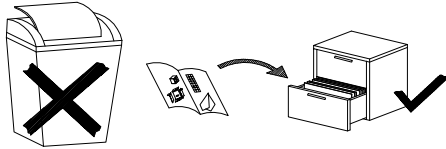

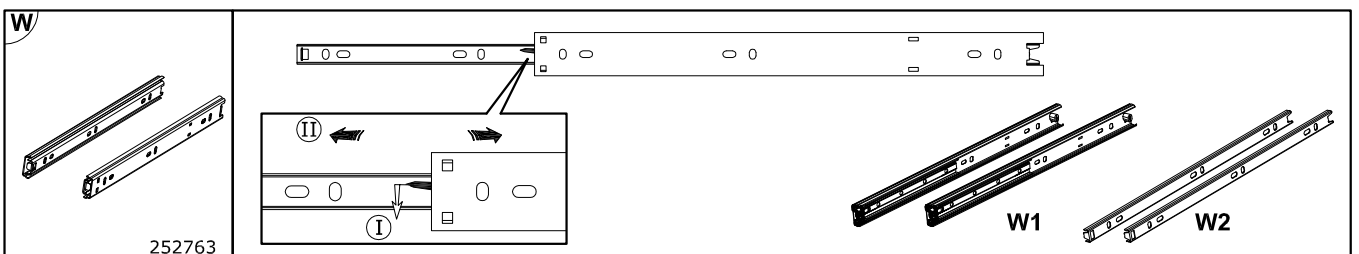
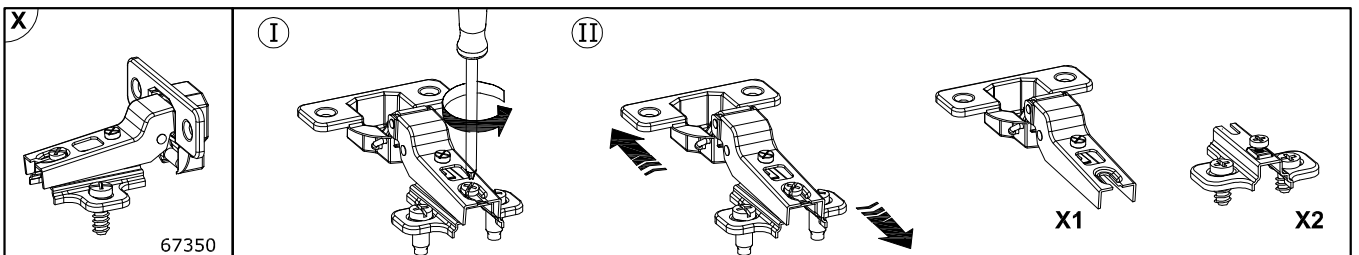

<b>A</b> Ø8x30 mm  x42 92597	<b>B</b> Ø8x50 mm  x6 92601	<b>C</b> Ø6,5x36,5 mm  x30 4066	<b>D</b> Ø6,5x76 mm  x6 4062	<b>E</b> Ø15x12 mm  x42 3996
<b>F</b> Ø20 mm  x28 136239	<b>G</b> Ø5x16 mm  x12 4017	<b>H</b> 75x15x32 mm  x2 71900	<b>J</b> 30x30x18 mm  x12 79844	<b>K</b> Ø3x13 mm  x4 3912
<b>L</b> Ø3,5x16 mm  x156 3918	<b>M</b> Ø4x25 mm  x22 145556	<b>N</b> Ø6,4x50 mm  x24 3884	<b>O</b> 4 mm  x1 3984	<b>P</b> 1,2X20 mm  x104 3975
<b>R</b> 23x10 mm  x28 77793	<b>S</b> Ø16x5 mm  x12 70313	<b>T</b> 42x17x20 mm  x4 4069	<b>U</b> 18x18x14 mm  x4 243136	<b>W</b> 400x27 mm  x6 252763
<b>X</b> Ø35 mm, KR8  x15 67350	<b>Y</b> 138 mm  x11 167314	<b>Z</b> 969 mm  x2 83086	<b>A1</b> 384 mm  x3 69509	<b>B1</b> 1234 mm  x1 IN00378
<b>C1</b> 1867 mm  x1 IN00378				

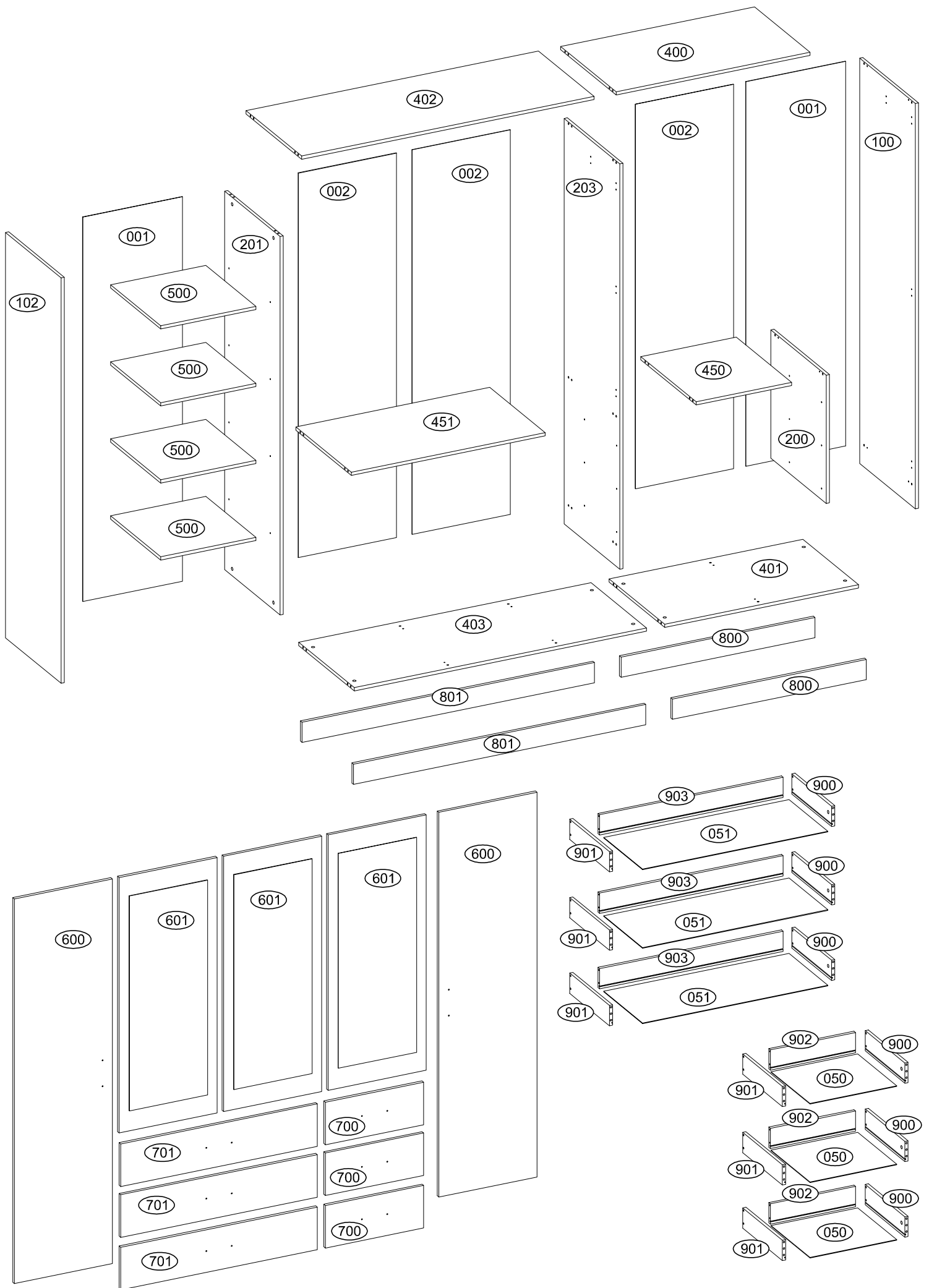

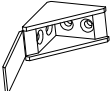

1

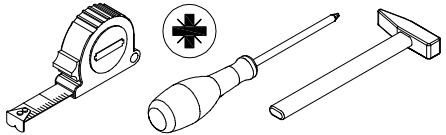
<b>S</b> Ø16x5 mm  x4 70313	<b>J</b> 30x30x18 mm  x8 79844	<b>L</b> Ø3,5x16 mm  x32 3918	
--	---	--	--

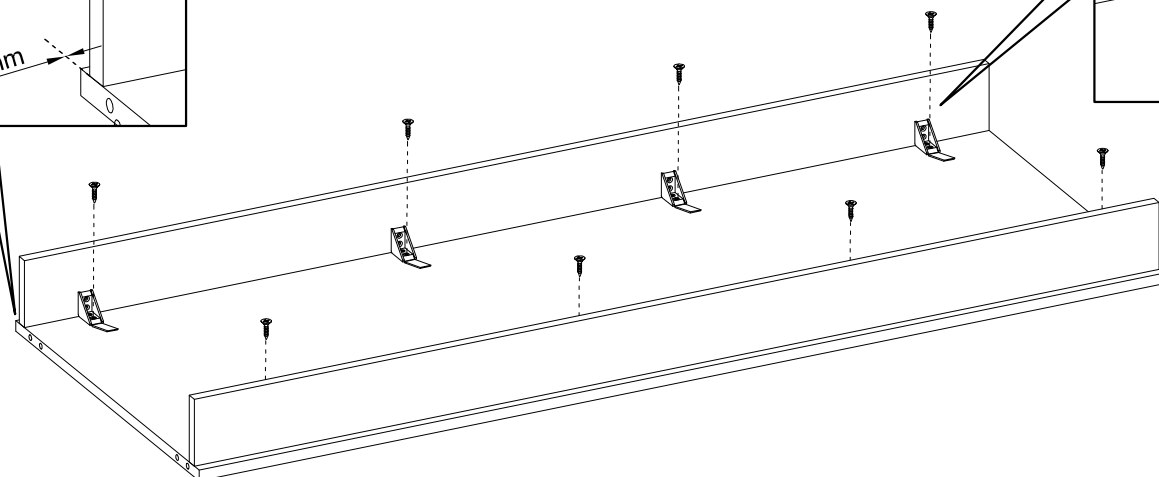
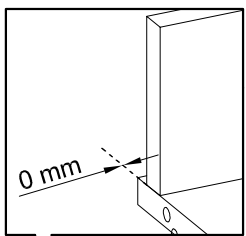
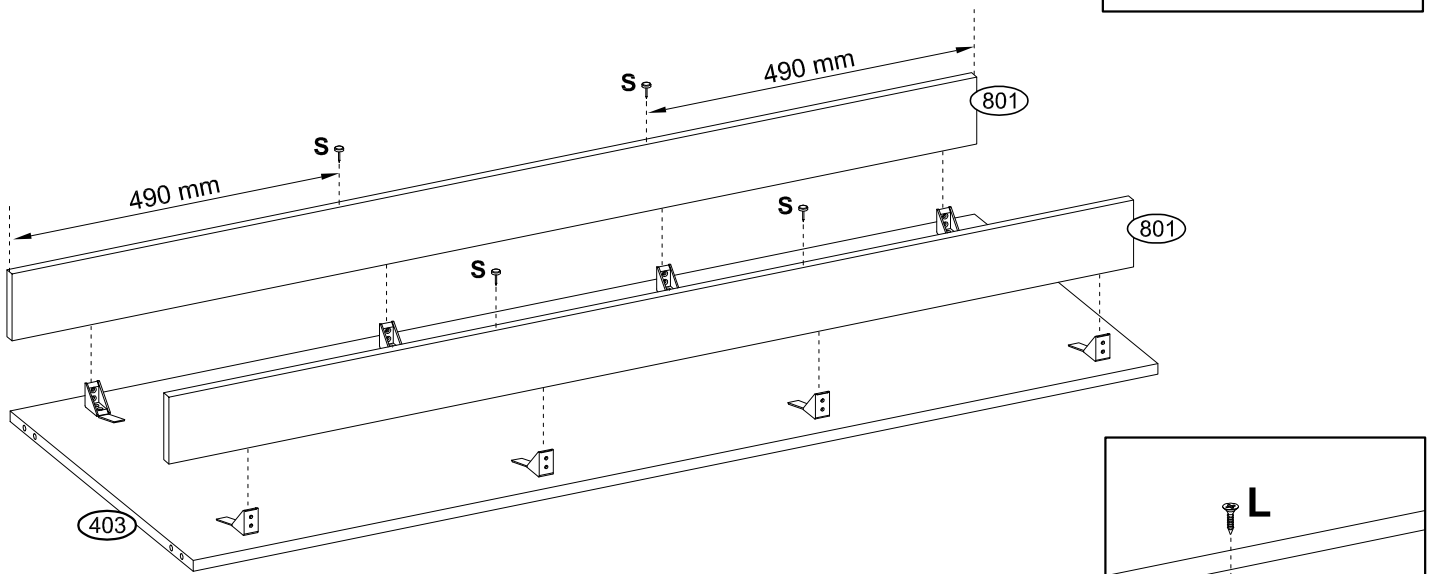
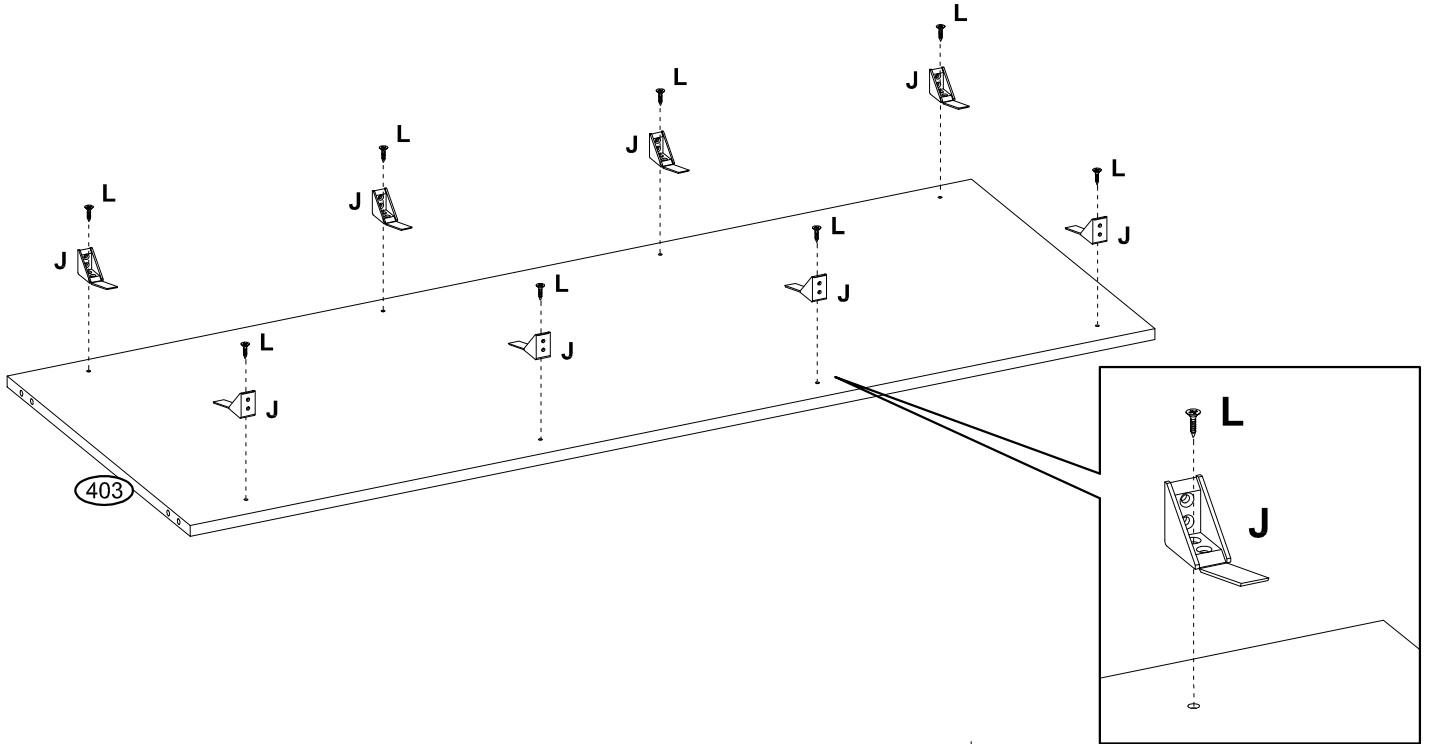

2

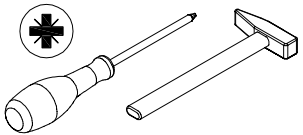
<b>A</b> Ø8x30 mm x2 92597	<b>C</b> Ø6,5x36,5 mm x2 4066	
-------------------------------------	--	--

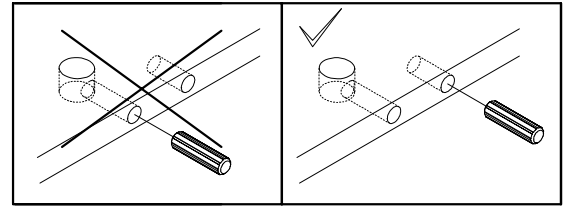
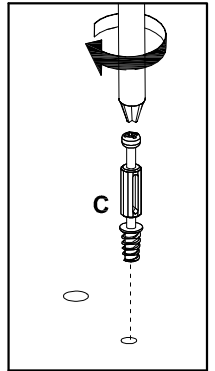
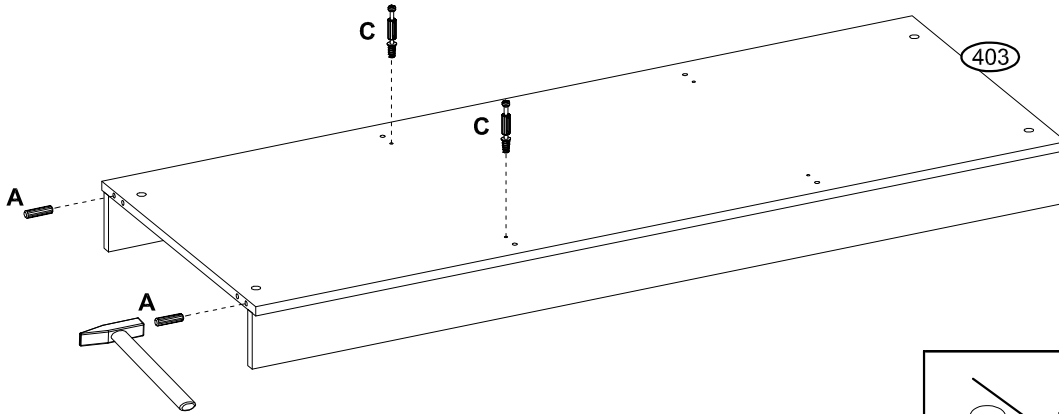

3

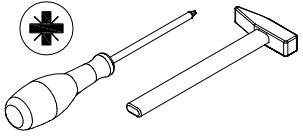
<b>A</b> Ø8x30 mm x2 92597	<b>C</b> Ø6,5x36,5 mm x2 4066	
-------------------------------------	--	--

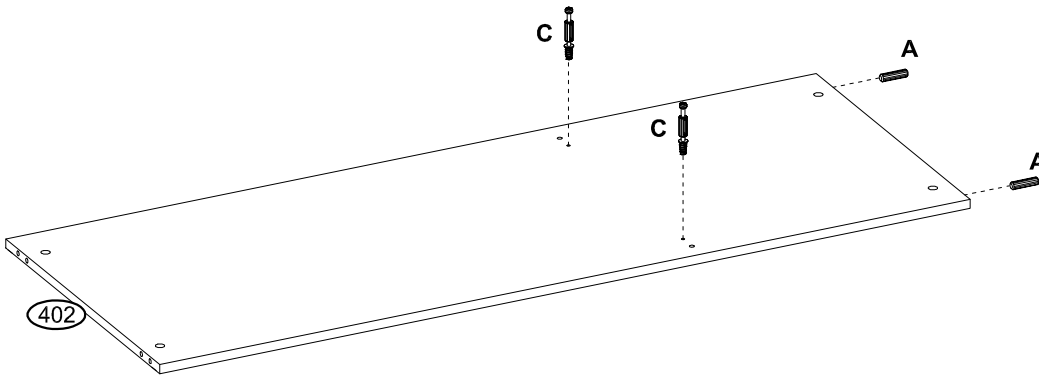



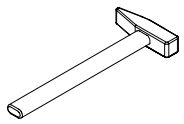

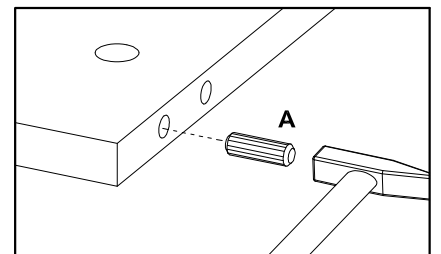
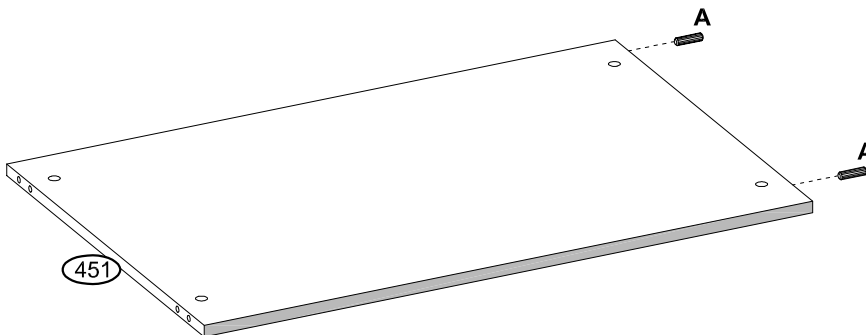
4

<b>A</b> Ø8x30 mm x2 92597		
-------------------------------------	--	---





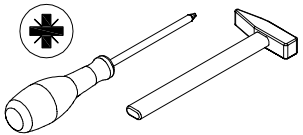
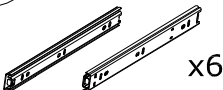
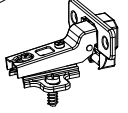

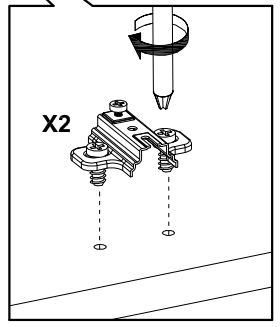
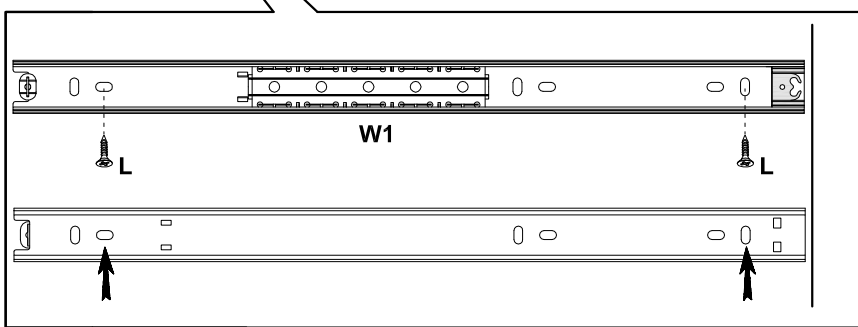
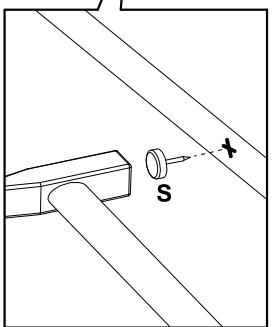
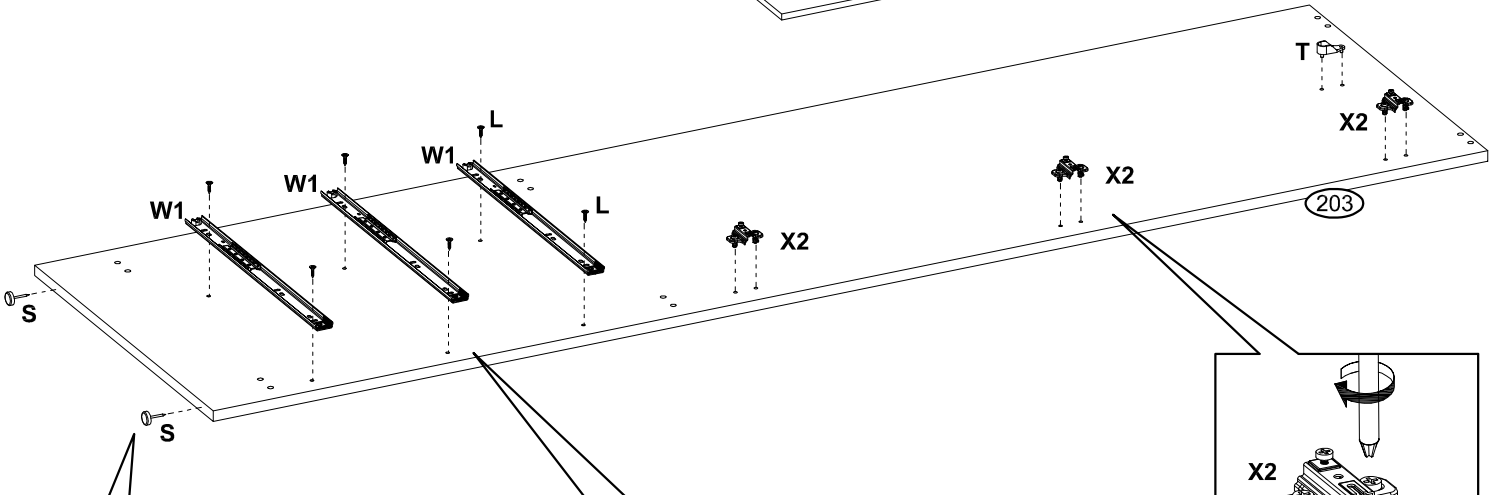
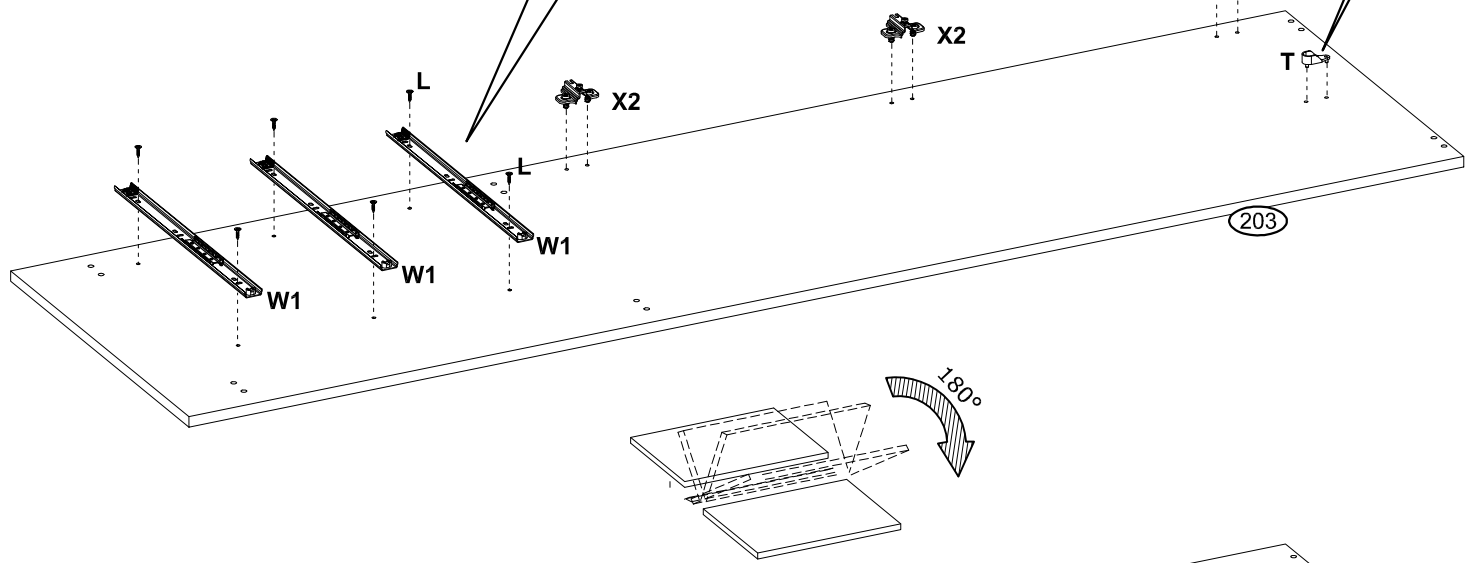
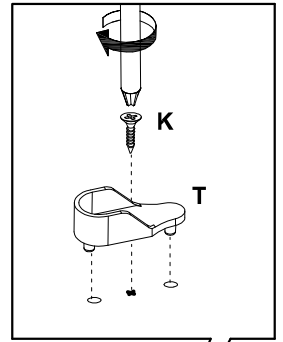
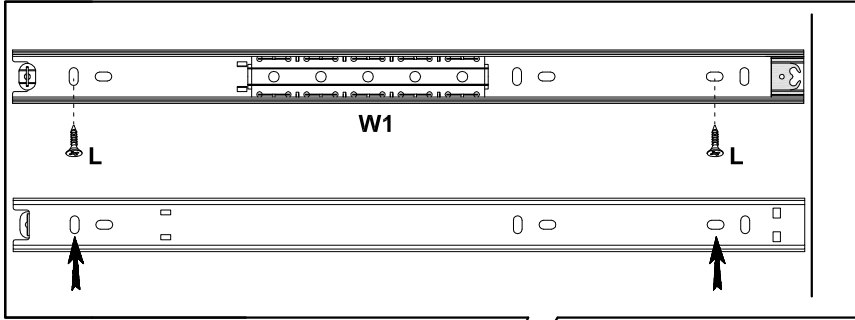

5

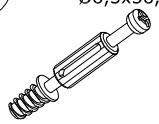
<b>K</b> Ø3x13 mm x2 3912 	<b>L</b> Ø3,5x16 mm x12 3918 	<b>S</b> Ø16x5 mm x2 70313 	<b>T</b> 42x17x20 mm x2 4069 	
<b>W</b> 400x27 mm x6 252763 	<b>X</b> Ø35 mm, KR8 x6 67350 			



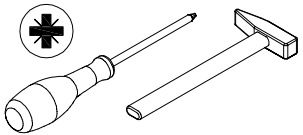

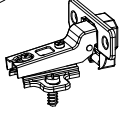

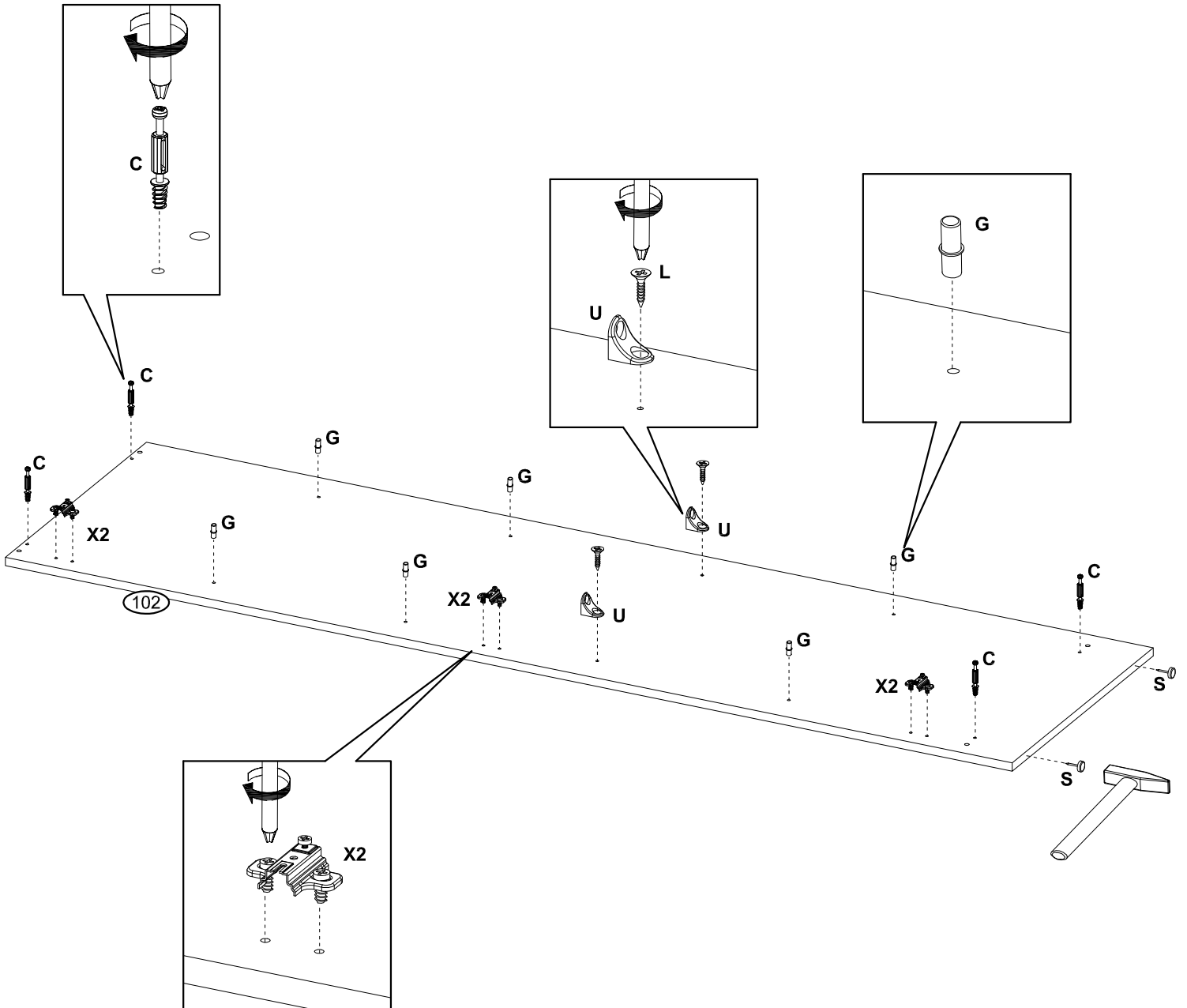

6

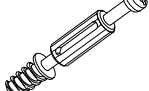
<b>C</b> Ø6,5x36,5 mm  <b>x4</b> 4066	<b>G</b> Ø5x16 mm  <b>x6</b> 4017	<b>L</b> Ø3,5x16 mm  <b>x2</b> 3918	<b>S</b> Ø16x5 mm  <b>x2</b> 70313	
<b>U</b> 18x18x14 mm  <b>x2</b> 243136	<b>X</b> Ø35 mm , KR8  <b>x3</b> 67350			

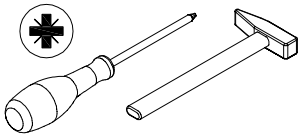

7

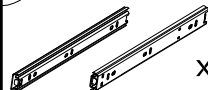
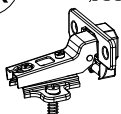
<b>A</b> Ø8x30 mm  x4 92597	<b>C</b> Ø6,5x36,5 mm  x2 4066	<b>G</b> Ø5x16 mm  x6 4017	<b>K</b> Ø3x13 mm  x1 3912	
<b>L</b> Ø3,5x16 mm  x8 3918	<b>T</b> 42x17x20 mm  x1 4069	<b>U</b> 18x18x14 mm  x2 243136	<b>W</b> 400x27 mm  x3 252763	
<b>X</b> Ø35 mm , KR8  x3 67350				

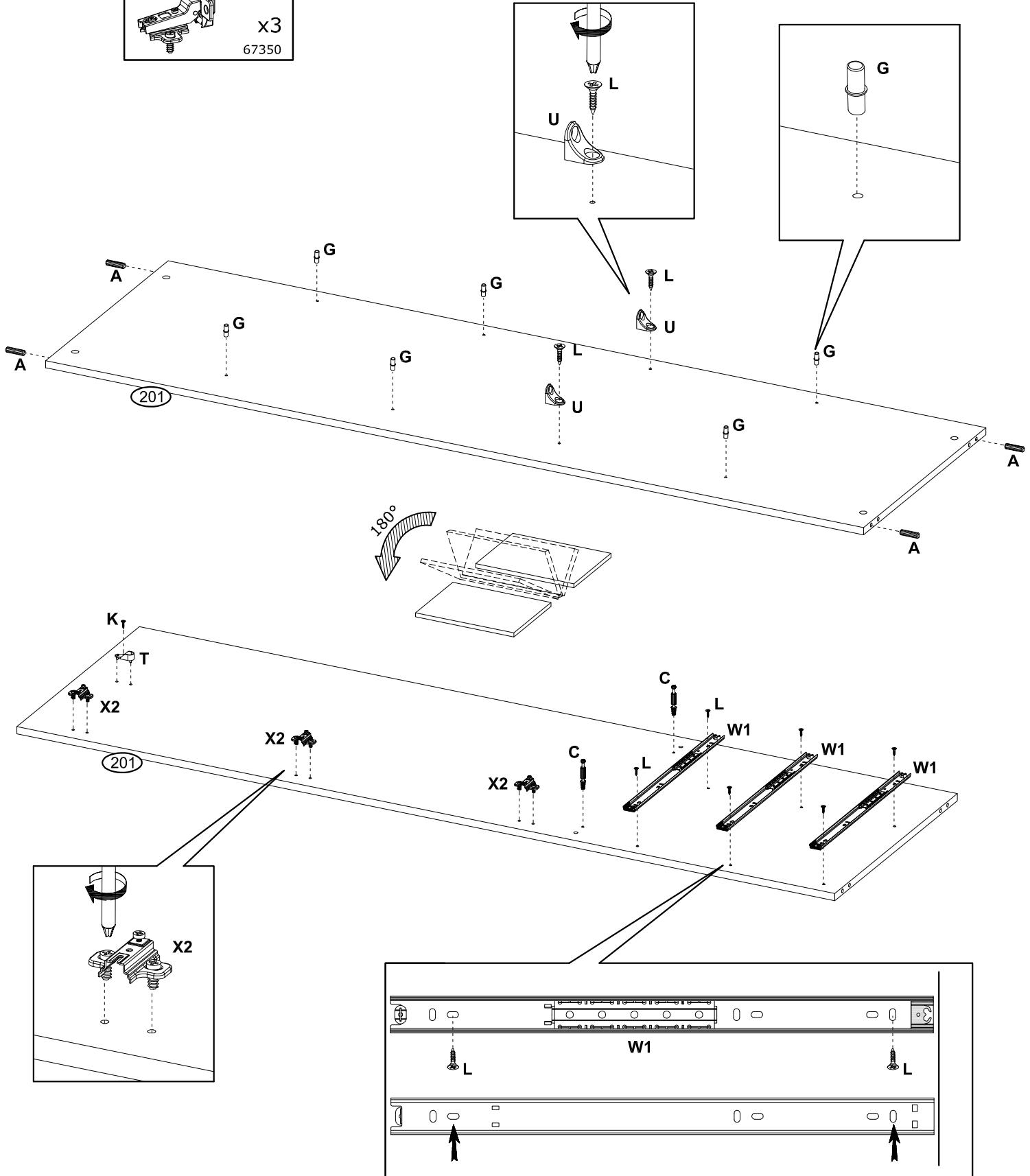

8

<b>E</b>	Ø15x12 mm		x2 3996	
----------	-----------	---	------------	--

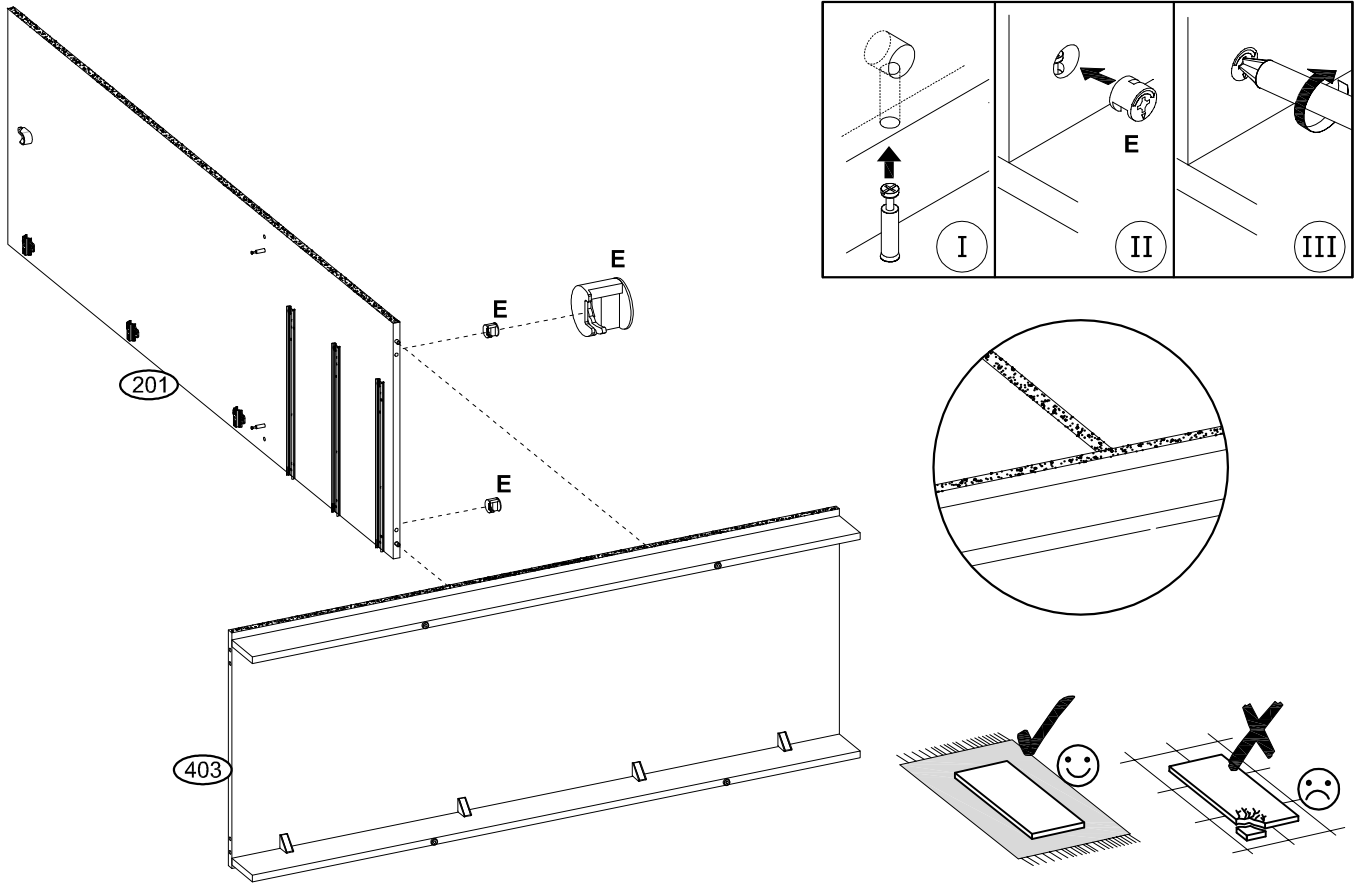

9

<b>E</b>	Ø15x12 mm		x2 3996	
----------	-----------	---	------------	---

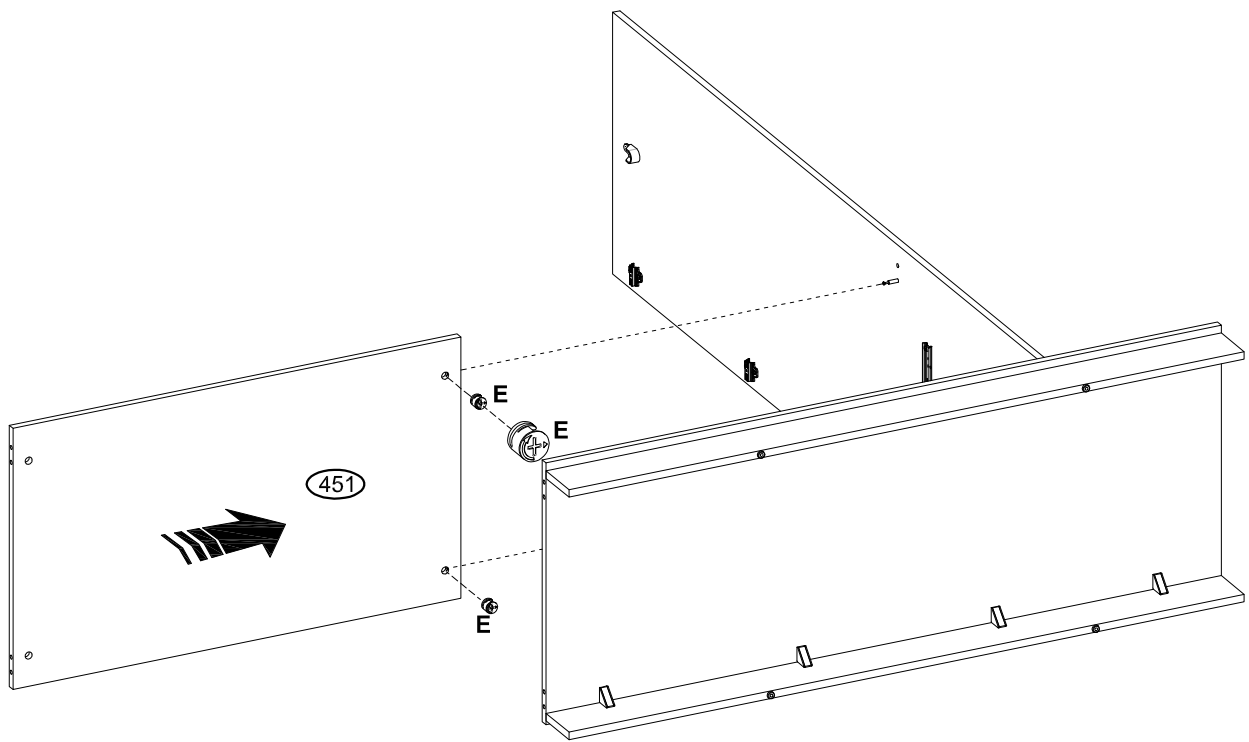

10

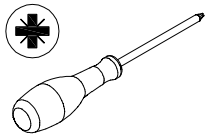
<b>E</b>	Ø15x12 mm		x2	3996	
----------	-----------	---	----	------	--

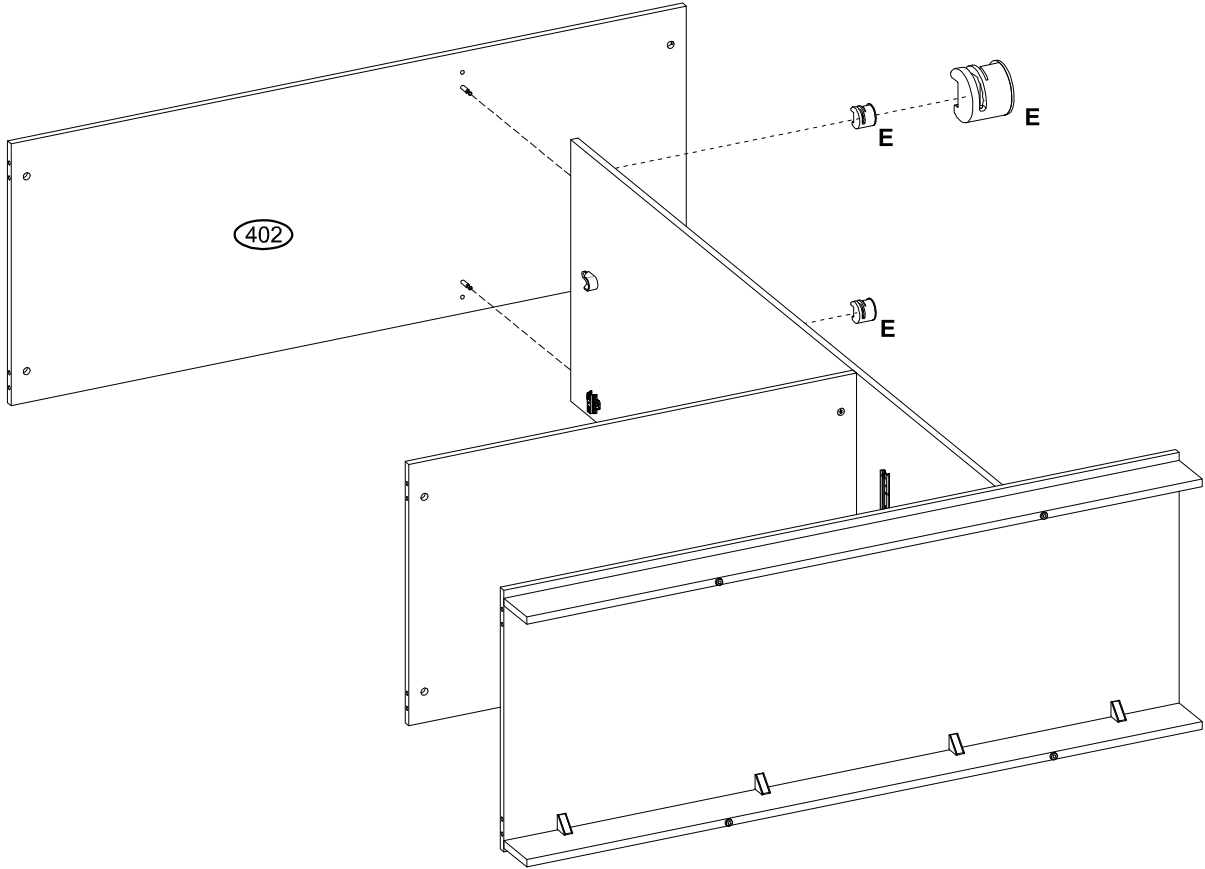

11

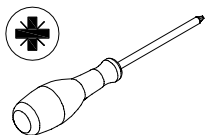
<b>E</b>	Ø15x12 mm		x4	3996	
----------	-----------	---	----	------	---

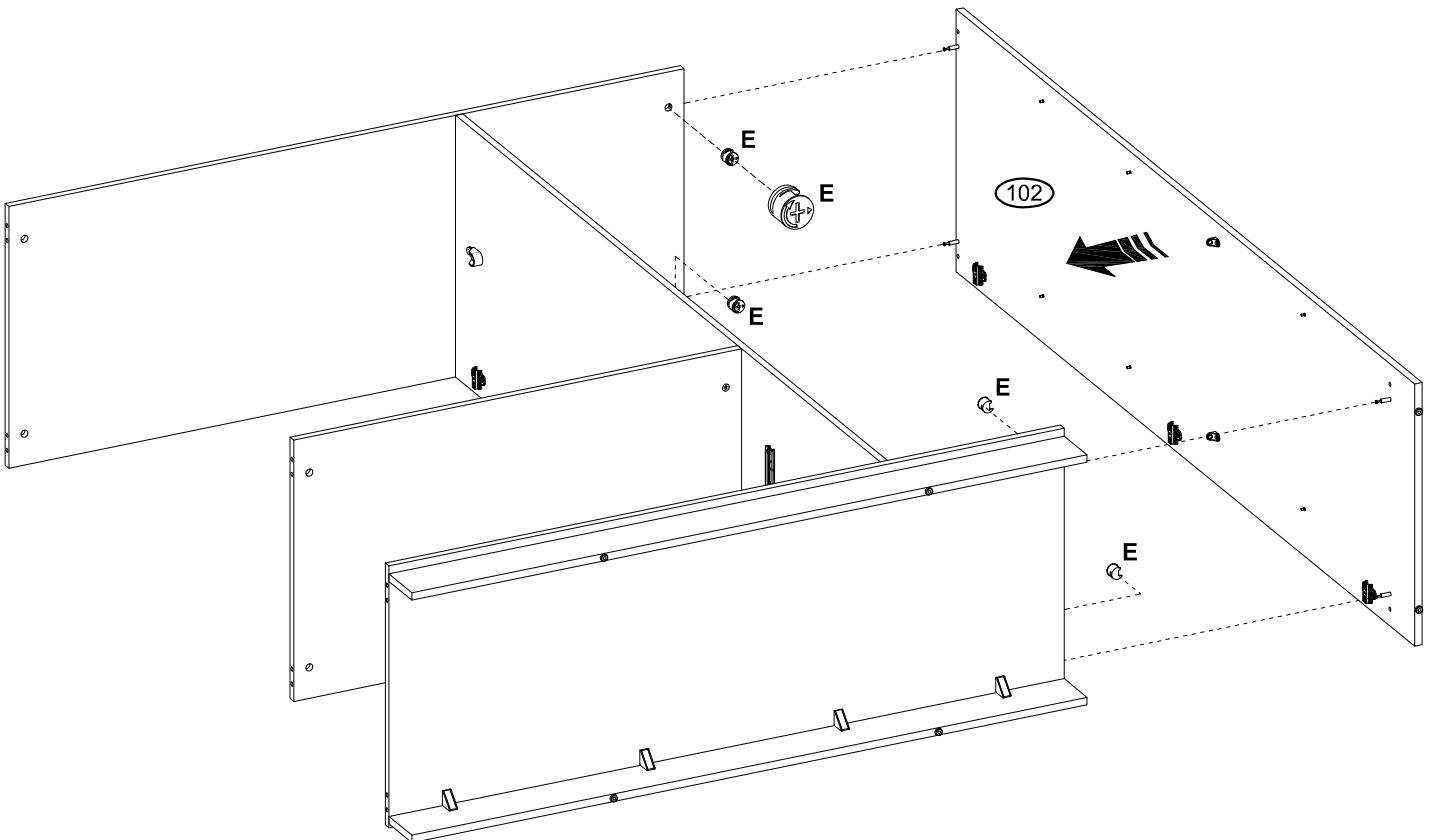

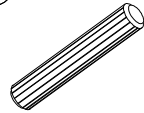
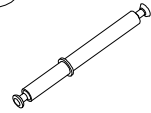
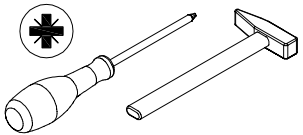

12

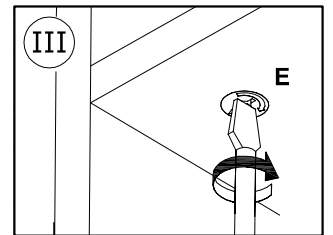
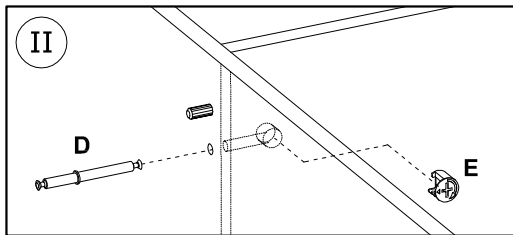
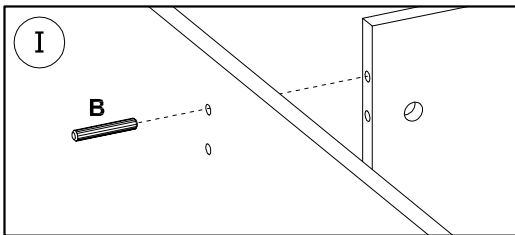
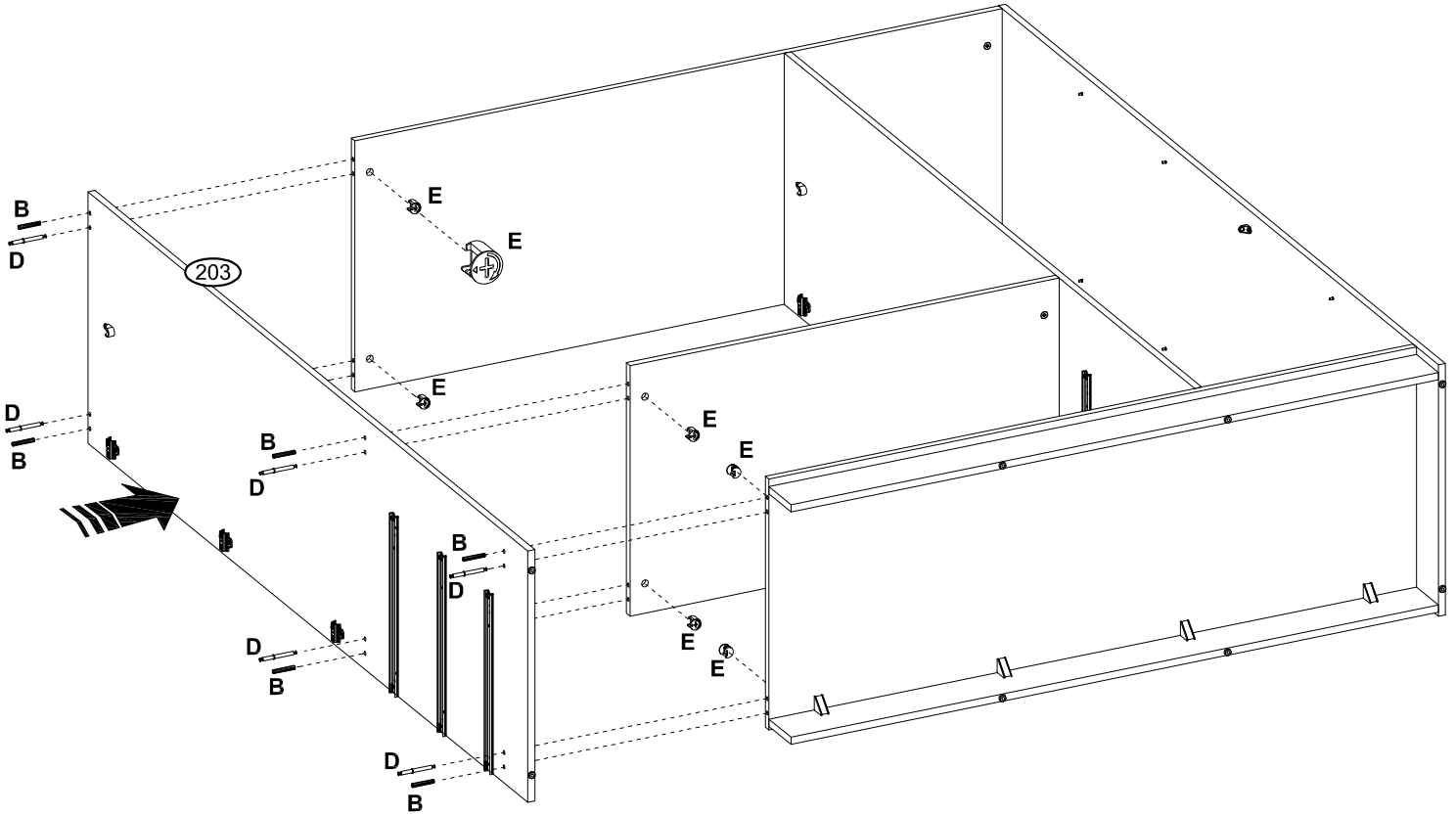
<b>E</b> Ø15x12 mm  x6 3996	<b>B</b> Ø8x50 mm  x6 92601	<b>D</b> Ø6,5x76 mm  x6 4062	
--	---	--	--

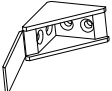

13

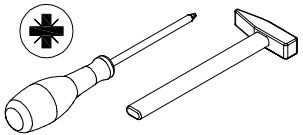
<b>S</b> Ø16x5 mm  x2 70313	<b>J</b> 30x30x18 mm  x4 79844	<b>L</b> Ø3,5x16 mm  x16 3918	
--	---	--	--

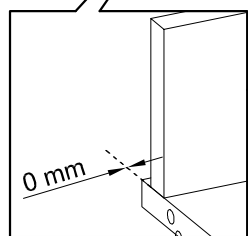
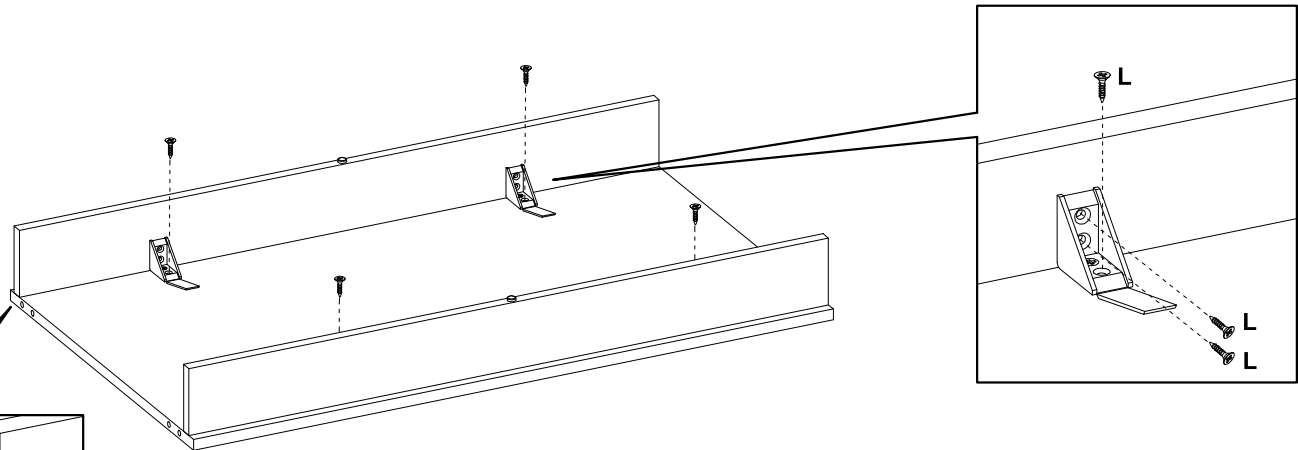
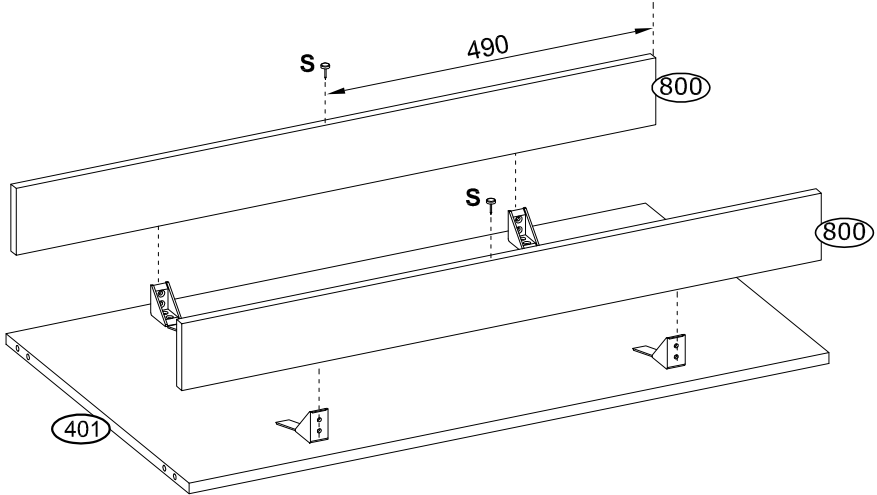
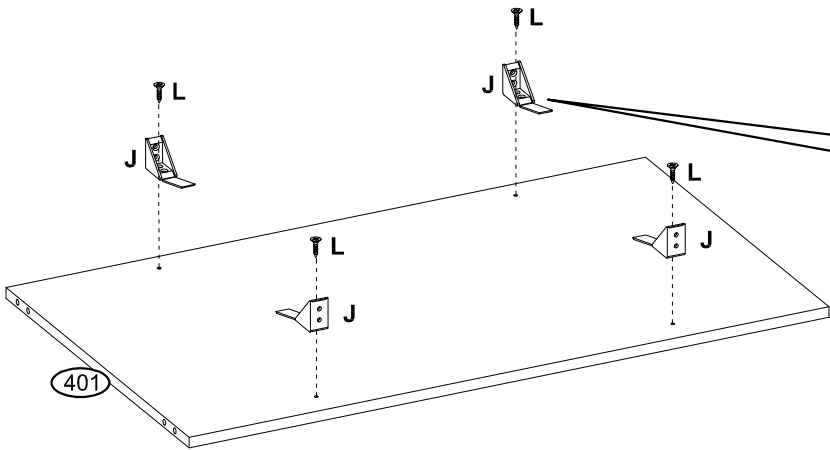

14

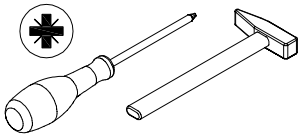
<b>A</b> Ø8x30 mm x2 92597	<b>C</b> Ø6,5x36,5 mm x2 4066	
-------------------------------------	--	--

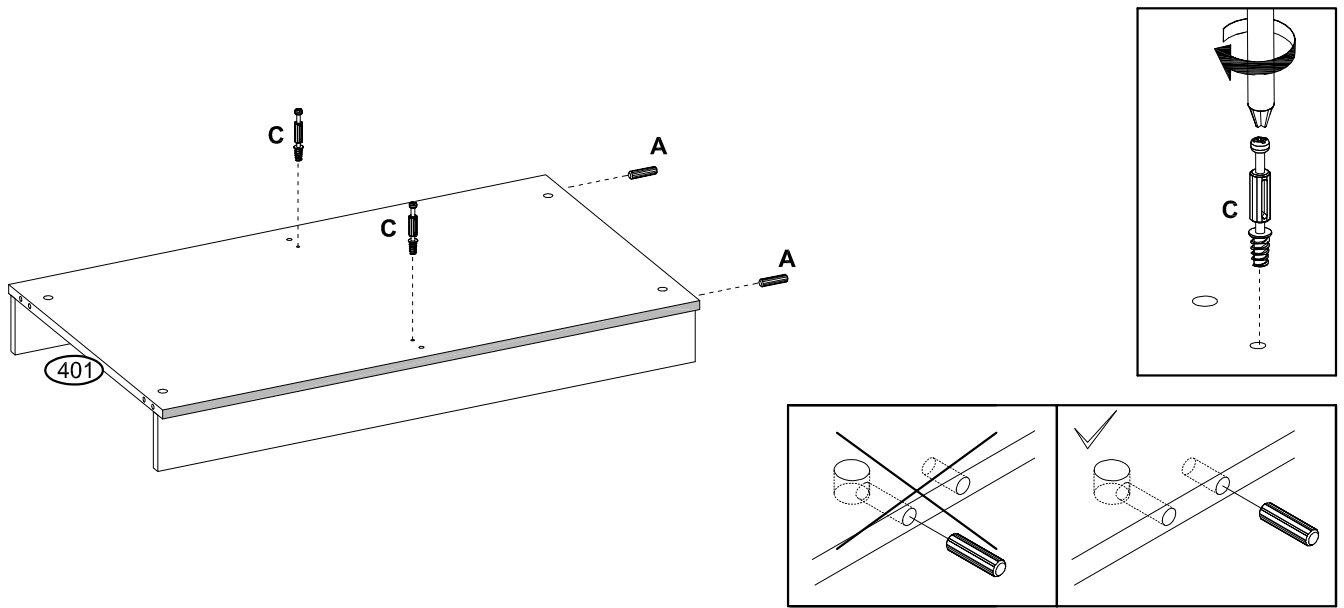

15

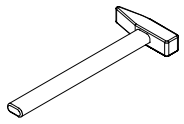
<b>A</b> Ø8x30 mm x2 92597		
-------------------------------------	--	--

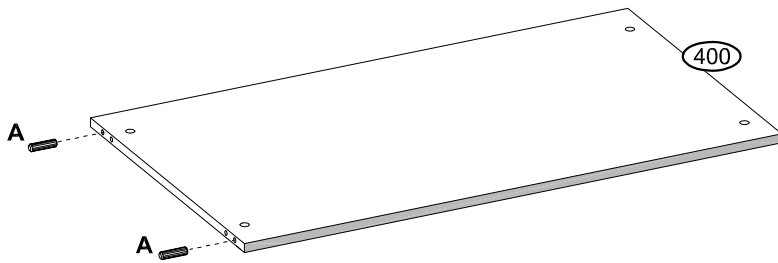

16

<b>A</b> Ø8x30 mm x2 92597		
-------------------------------------	--	---

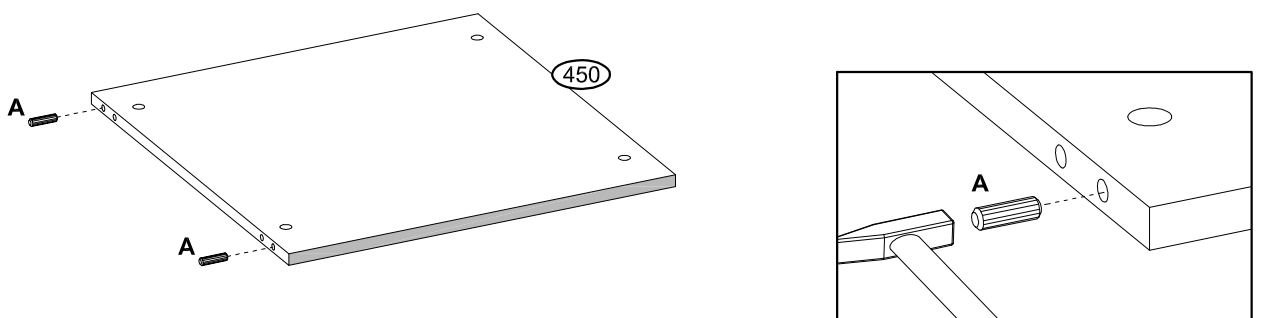

17

<b>A</b>	∅8x30 mm x2 92597	<b>C</b>	∅6,5x36,5 mm x2 4066	<b>L</b>	∅3,5x16 mm x6 3918	<b>W</b>	400x27 mm x3 252763	
----------	-------------------------	----------	----------------------------	----------	--------------------------	----------	---------------------------	--

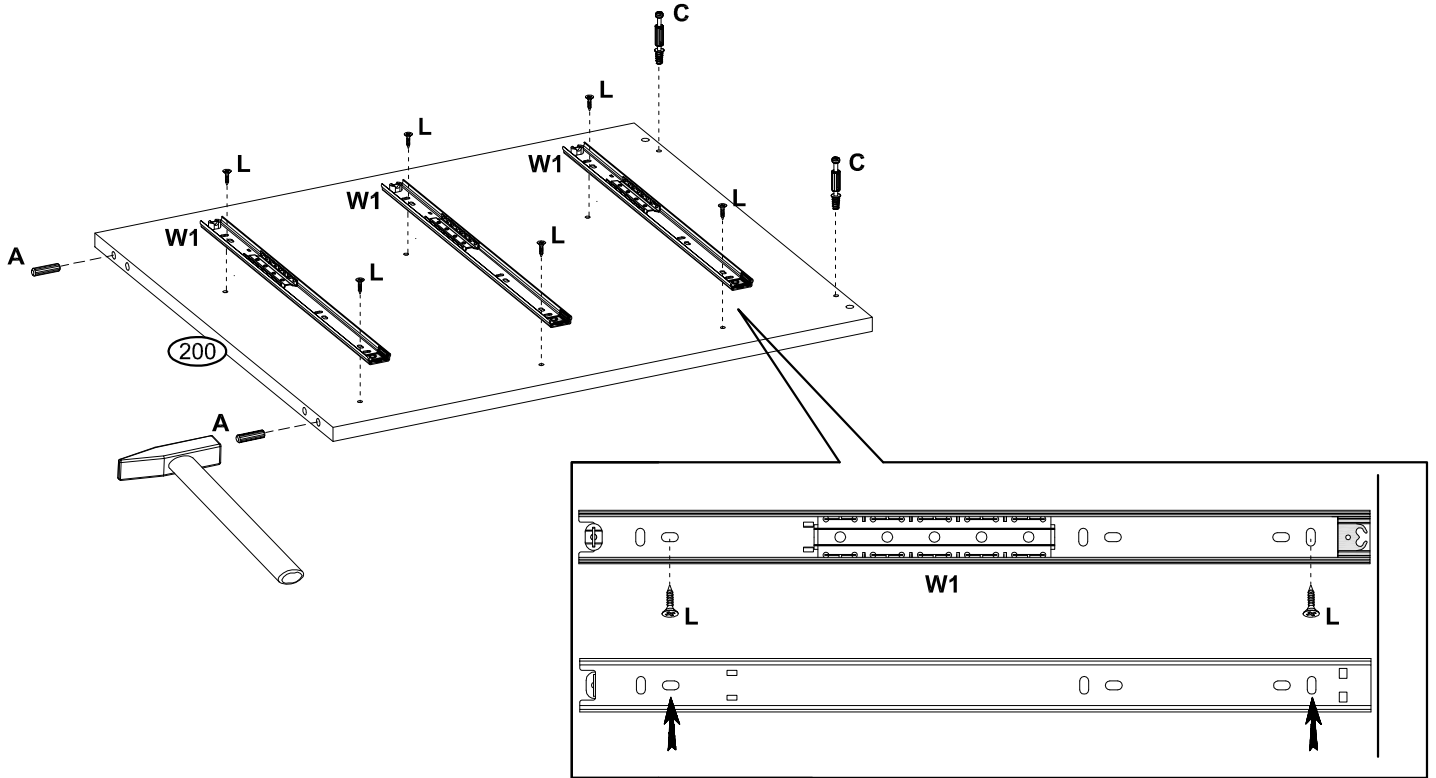

18

<b>C</b>	∅6,5x36,5 mm x4 4066	<b>K</b>	∅3x13 mm x1 3912	<b>S</b>	∅16x5 mm x2 70313	<b>T</b>	42x17x20 mm x1 4069	
<b>X</b>	∅35 mm , KR8 x3 67350							

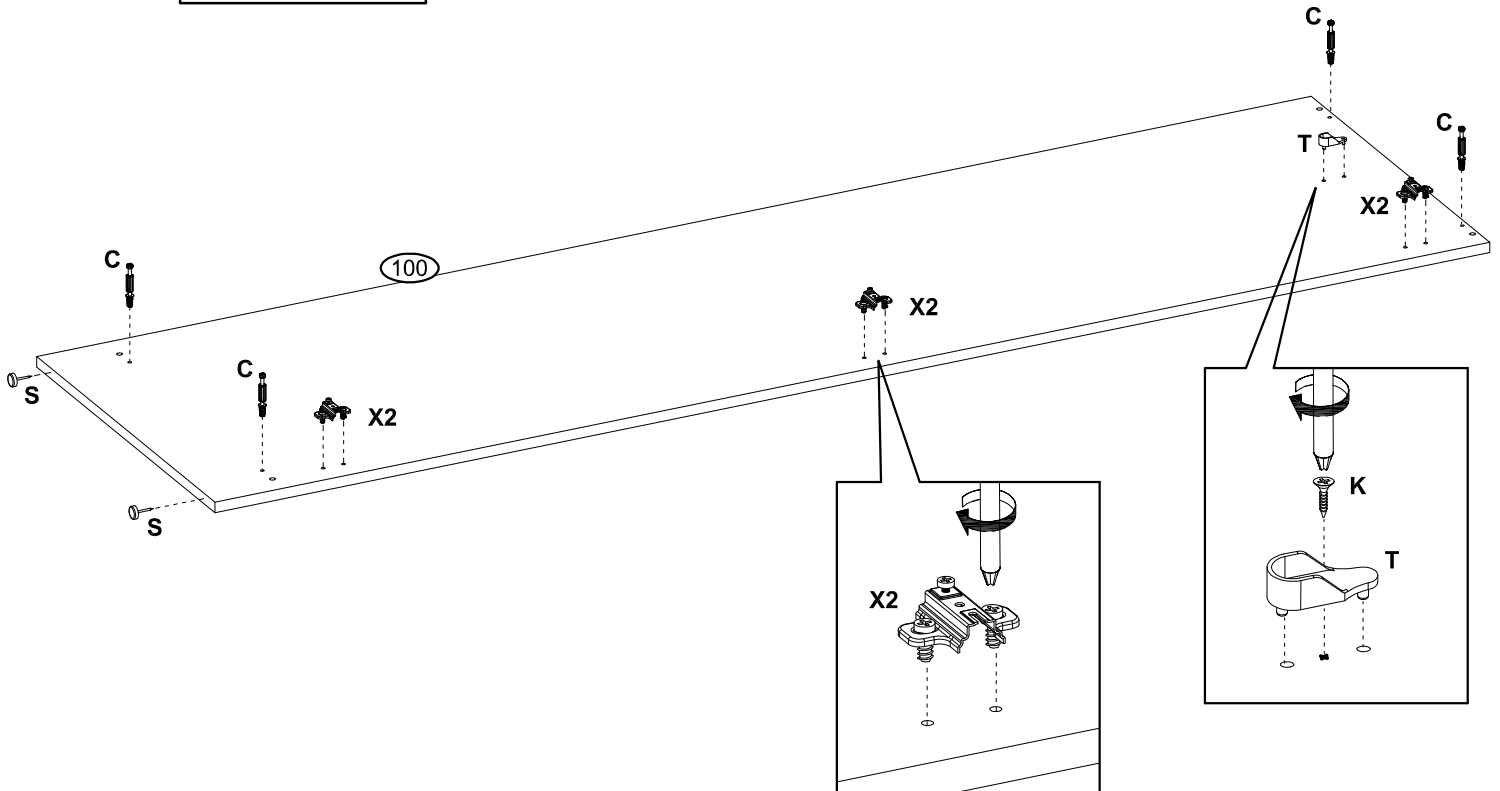

19

<b>E</b>	Ø15x12 mm		x2	3996	
----------	-----------	---	----	------	--

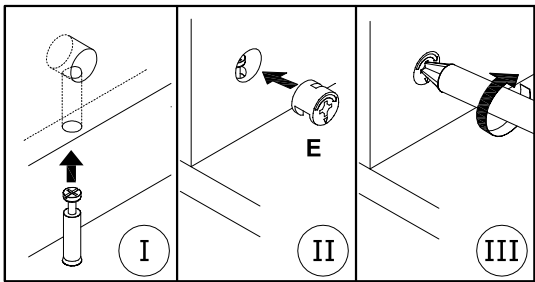
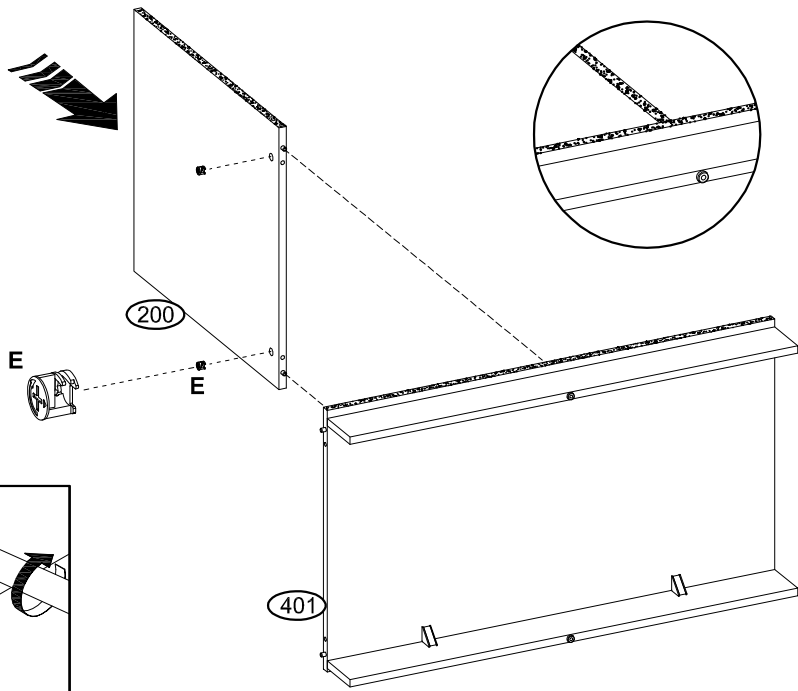

20

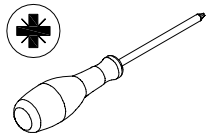
<b>E</b>	Ø15x12 mm		x2	3996	
----------	-----------	---	----	------	---

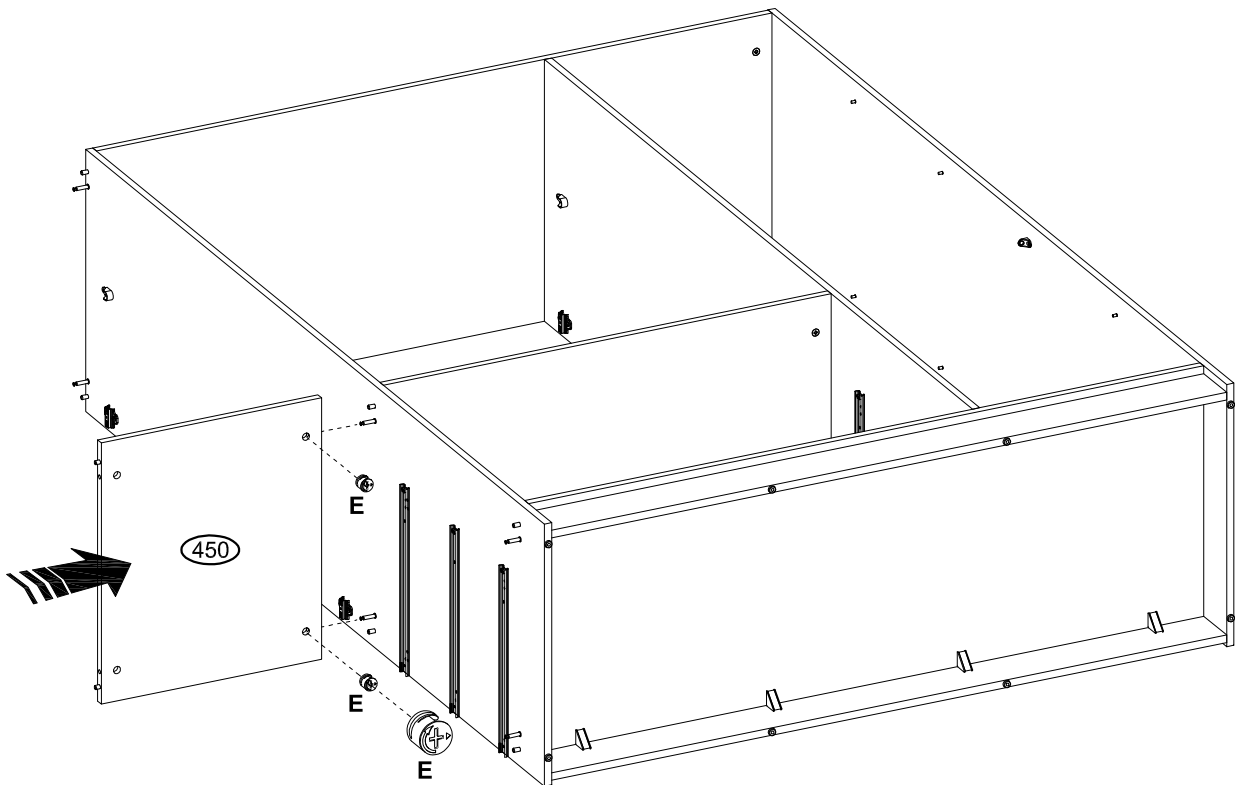

21

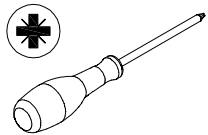
<b>E</b>	Ø15x12 mm		x4 3996	
----------	-----------	---	------------	--

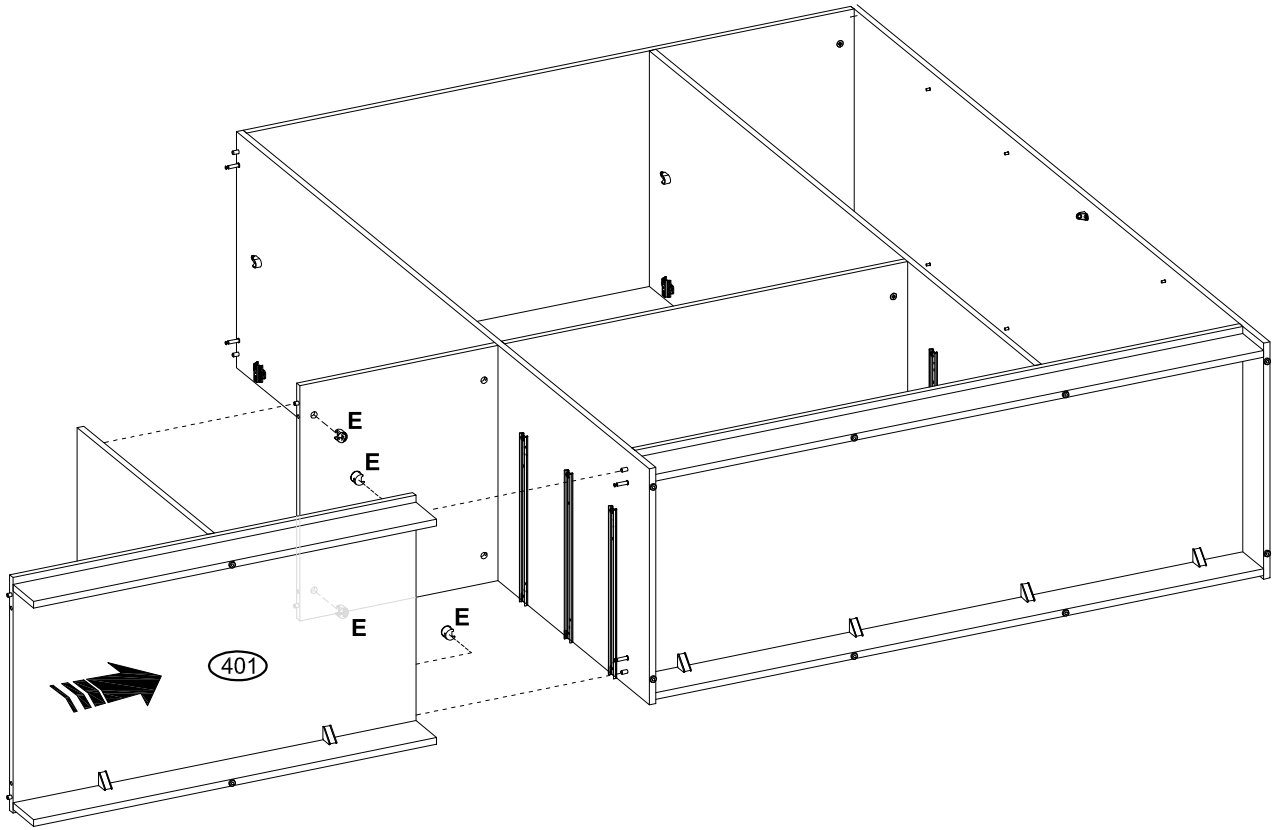

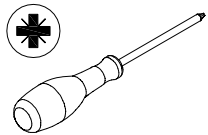

22

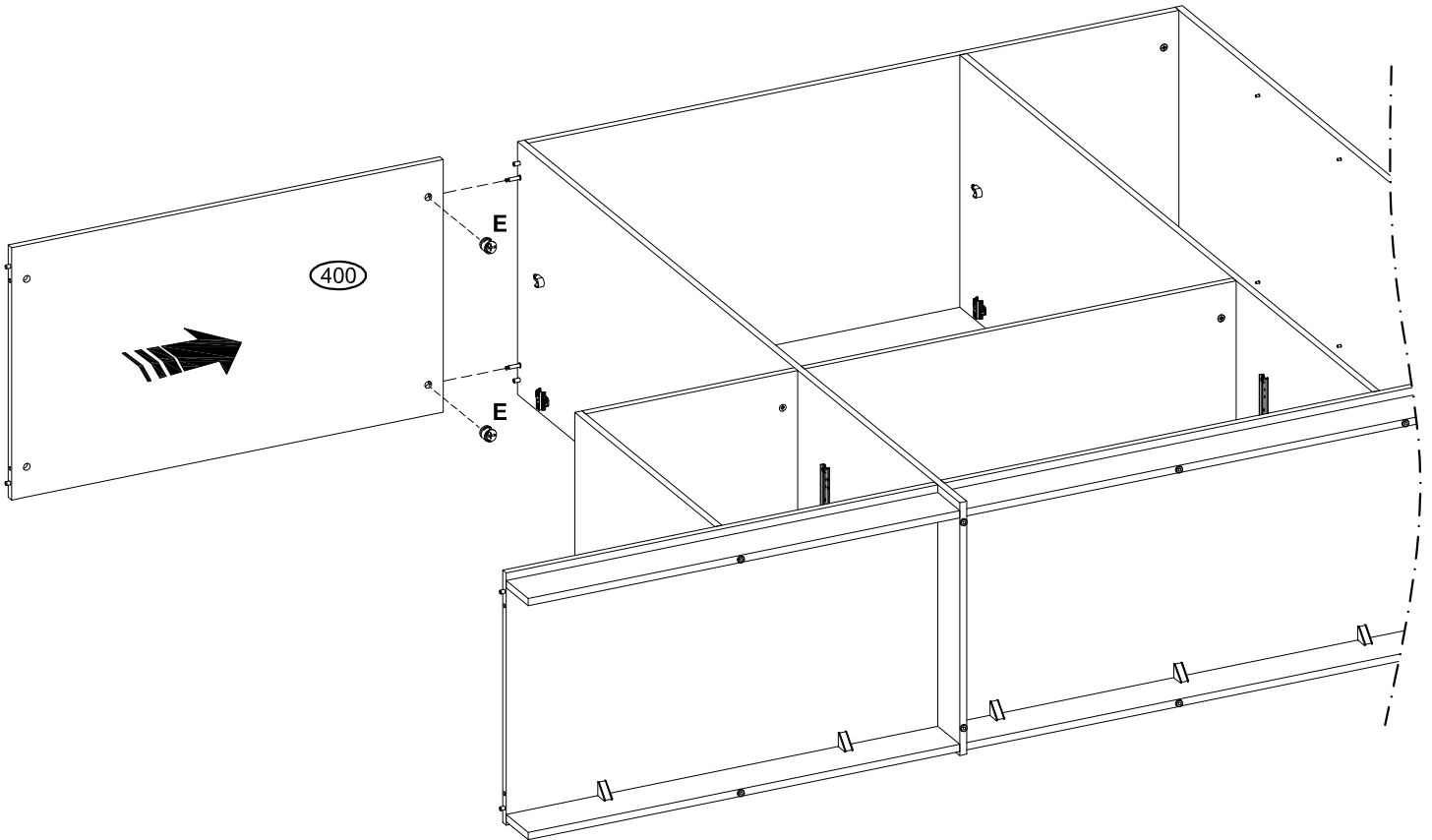
<b>E</b>	Ø15x12 mm		x2 3996	
----------	-----------	---	------------	---



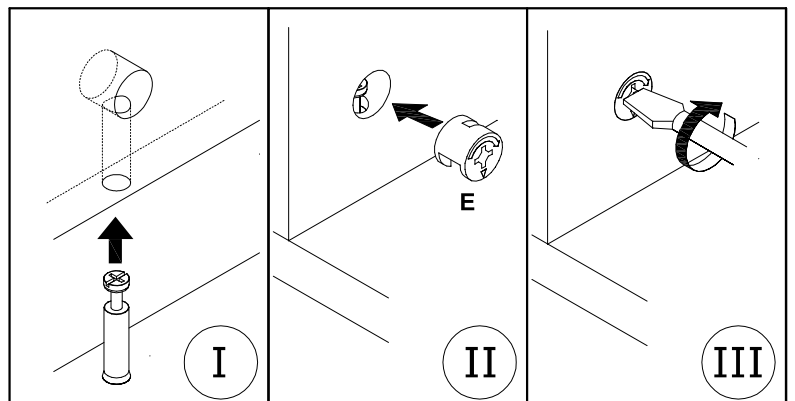
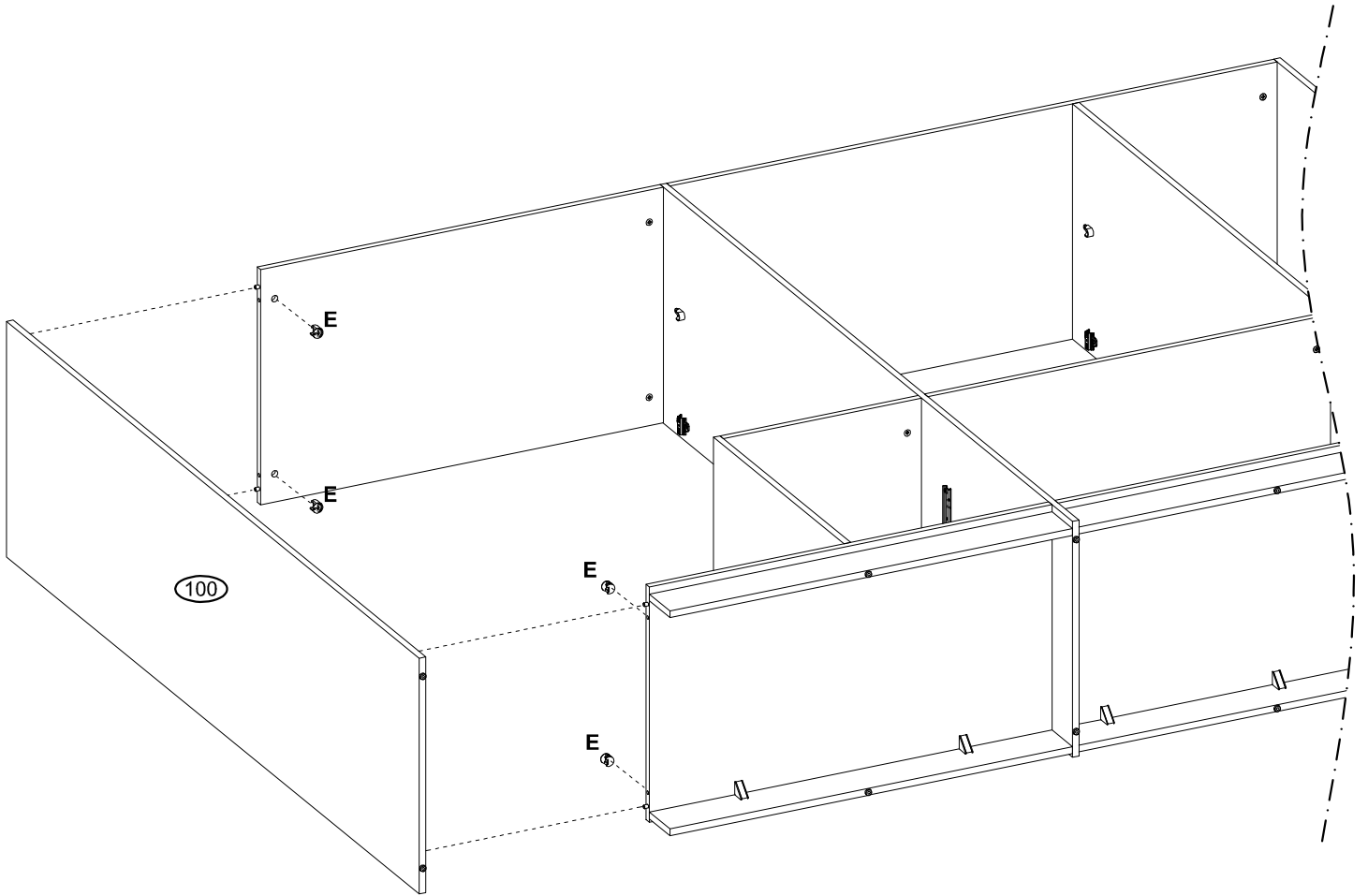

23

E	Ø15x12 mm	
	x4 3996	



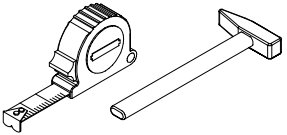

24

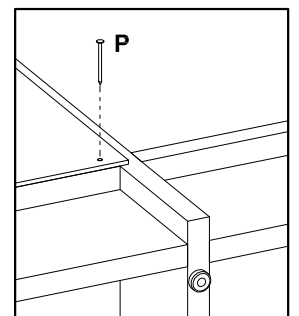
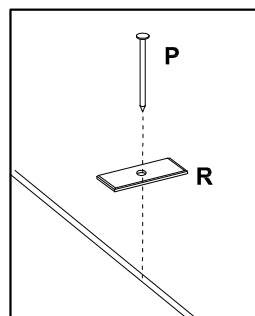
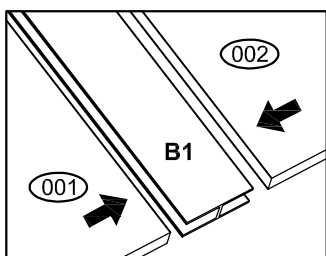
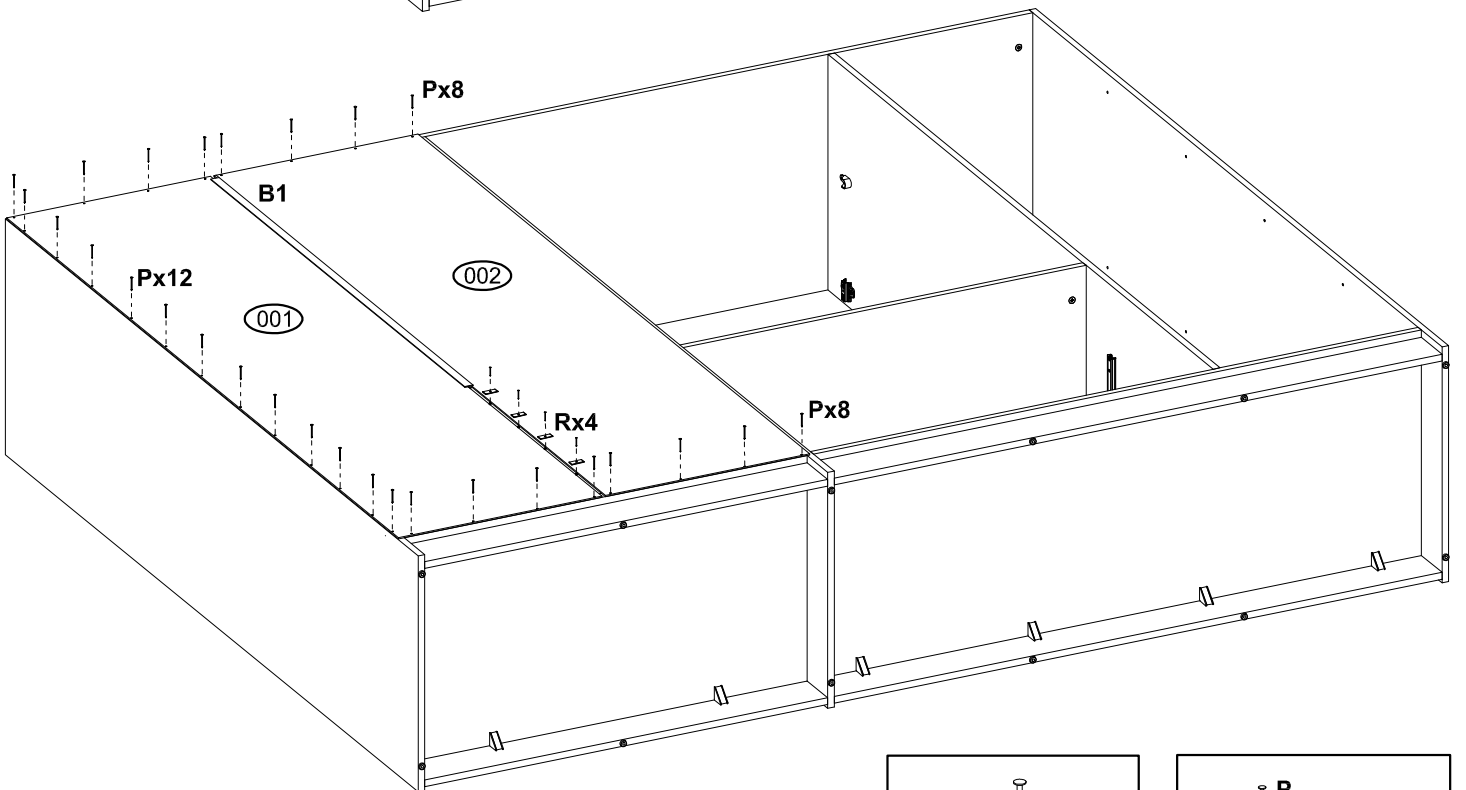
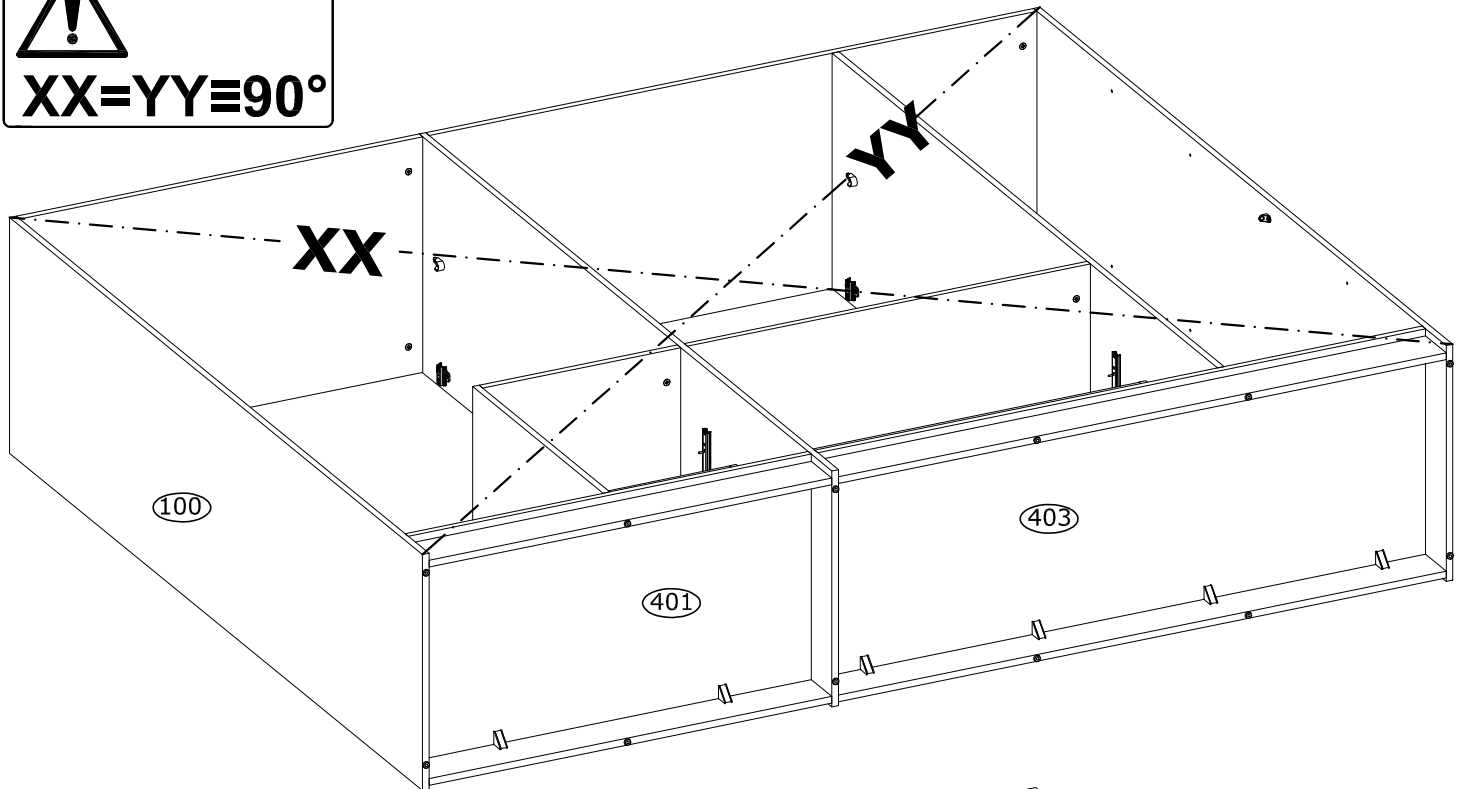
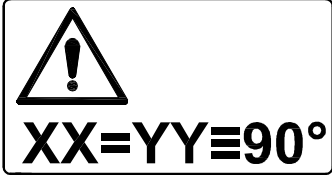
<b>B1</b> 1234 mm  x1 IN00378	<b>P</b> 1,2X20 mm  x32 3975	<b>R</b> 23x10 mm  x4 77793	
--	---	--	--

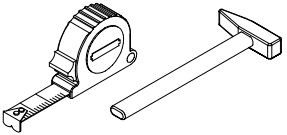

25

<b>C1</b>  1867 mm x1 IN00378	<b>P</b>  1,2X20 mm x72 3975	<b>R</b>  23x10 mm x24 77793	
--	---	---	--

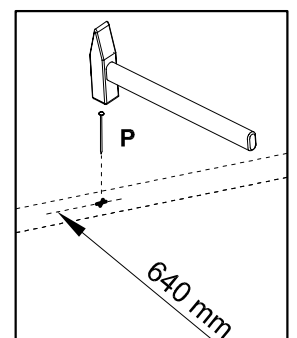
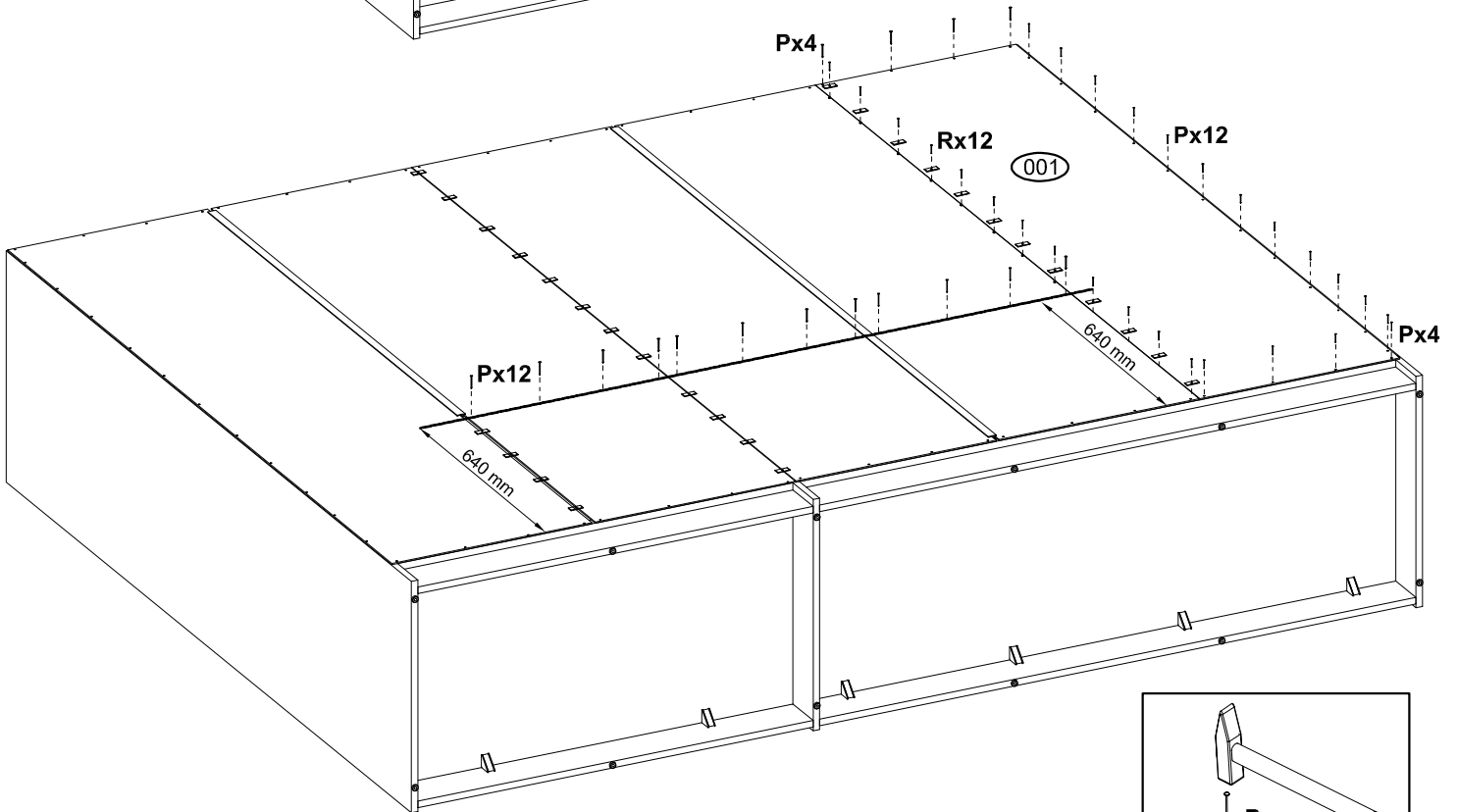
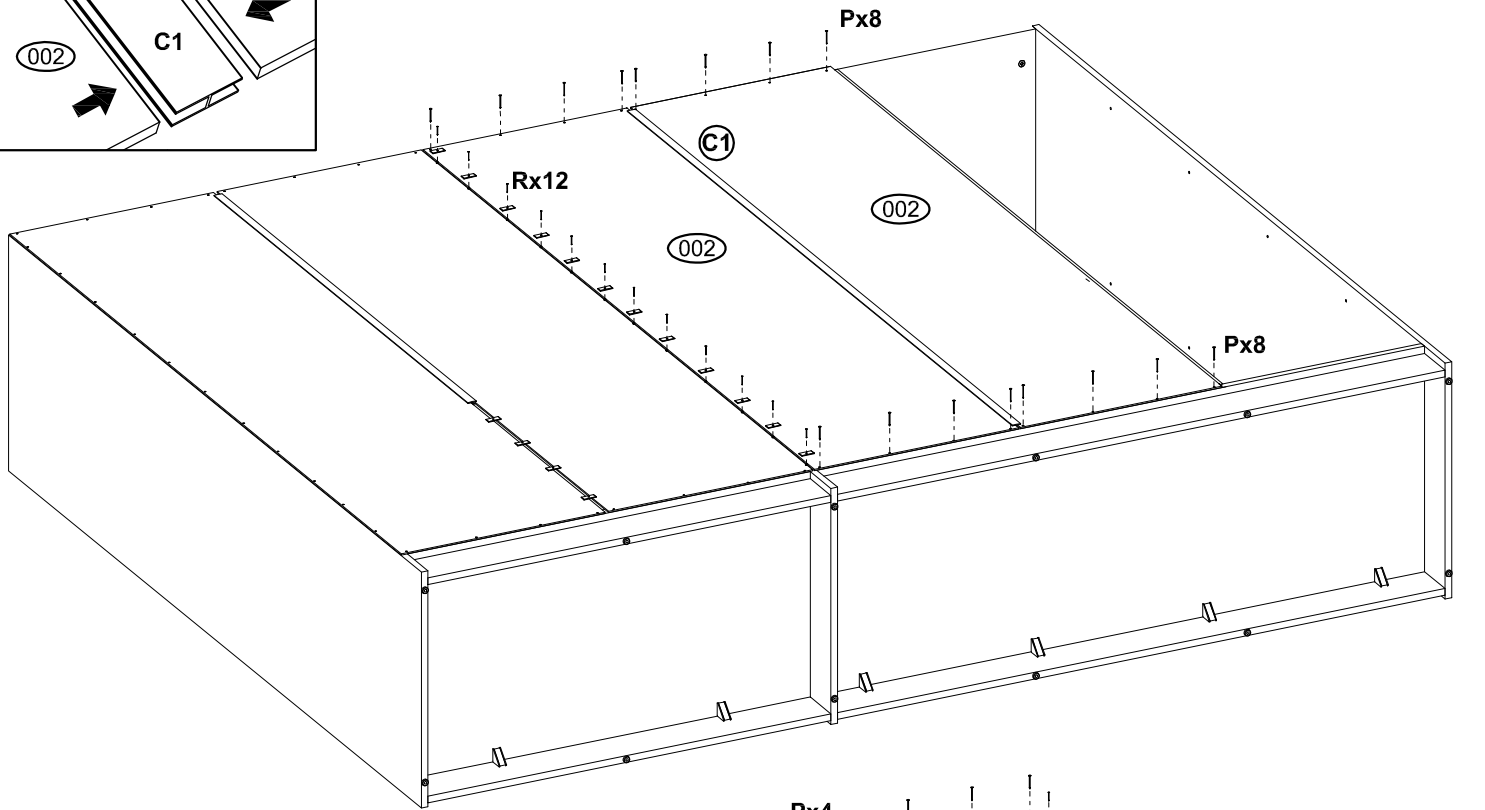
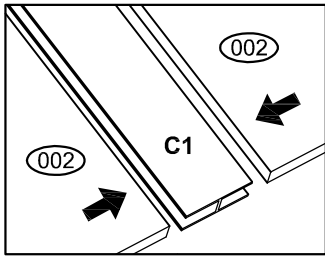

26

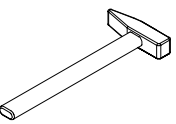
<b>A</b>  Ø8x30 mm x24 92597	
---	--

x6

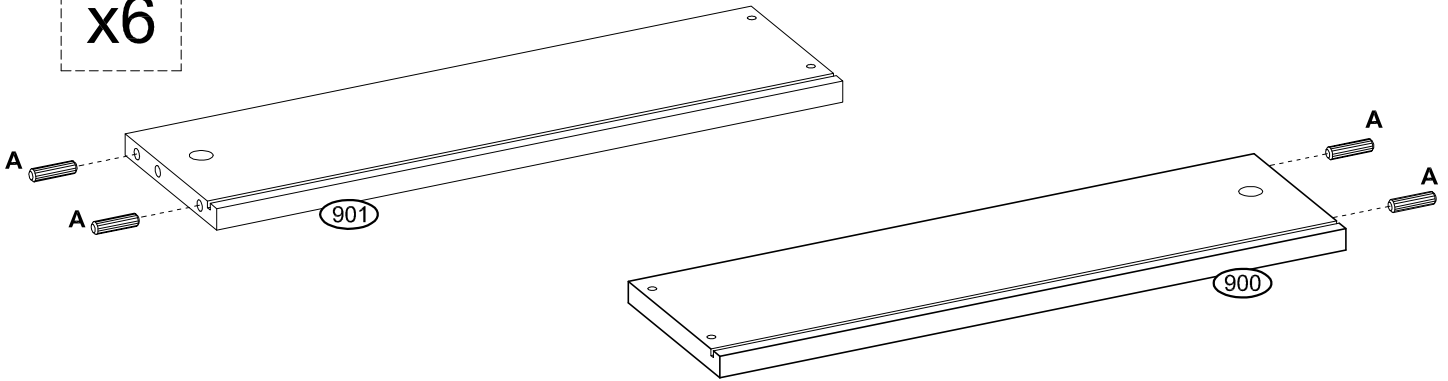

27

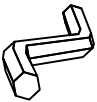
<b>N</b>  Ø6,4x50 mm x24 3884	<b>O</b>  4 mm x1 3984
---	--

x3

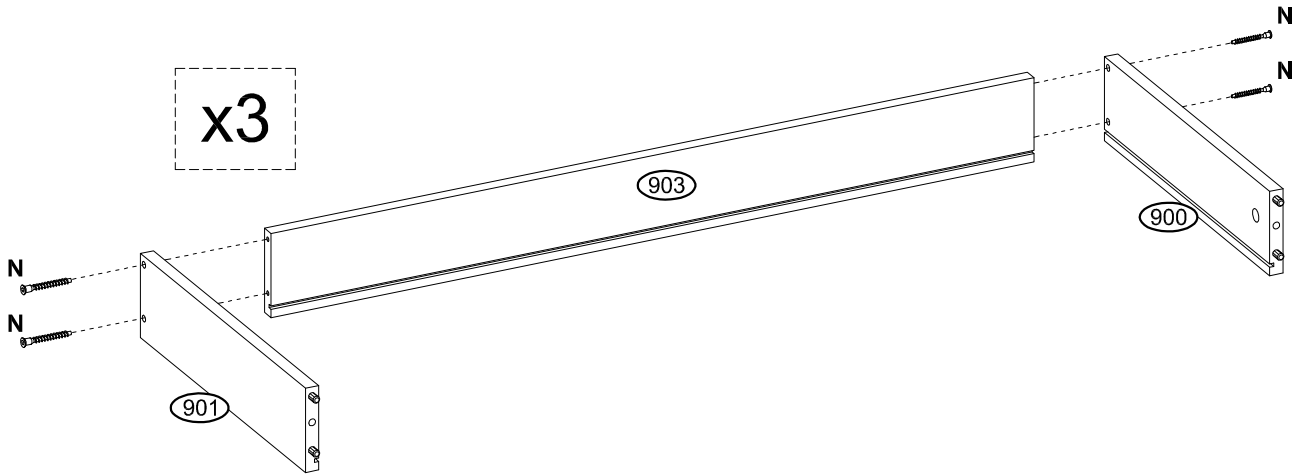

x3

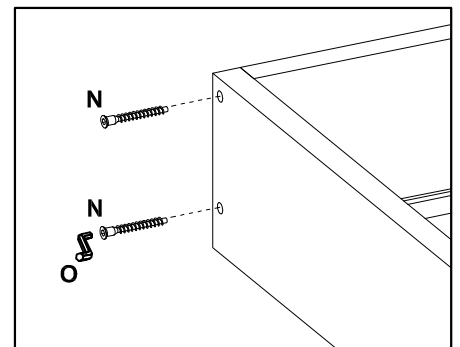
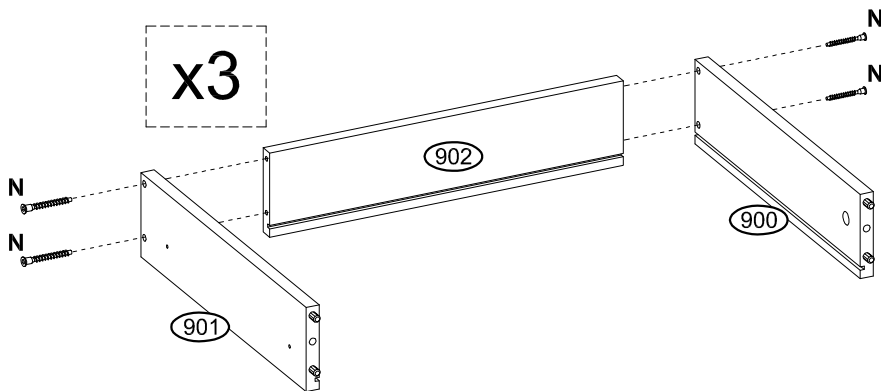

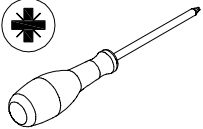

28

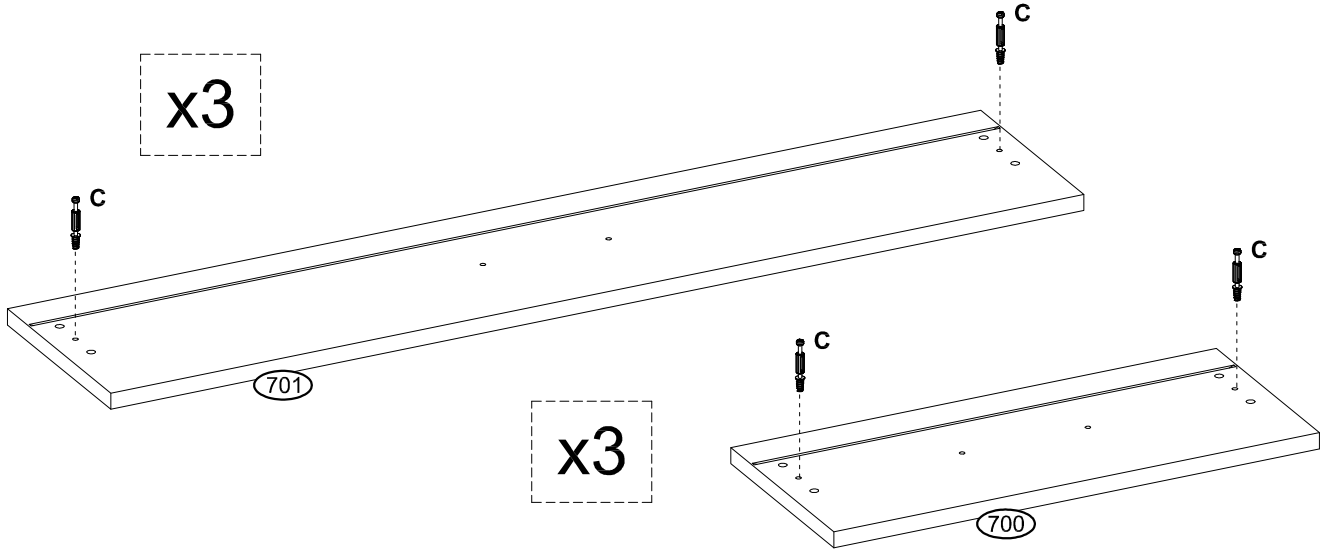
<b>C</b>  Ø6,5x36,5 mm x12 4066		
---	--	--

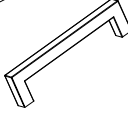
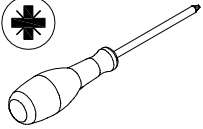

29

<b>E</b>  Ø15x12 mm x12 3996	<b>M</b>  Ø4x25 mm x12 145556	<b>Y</b>  138 mm x6 167314	
---	--	--	--

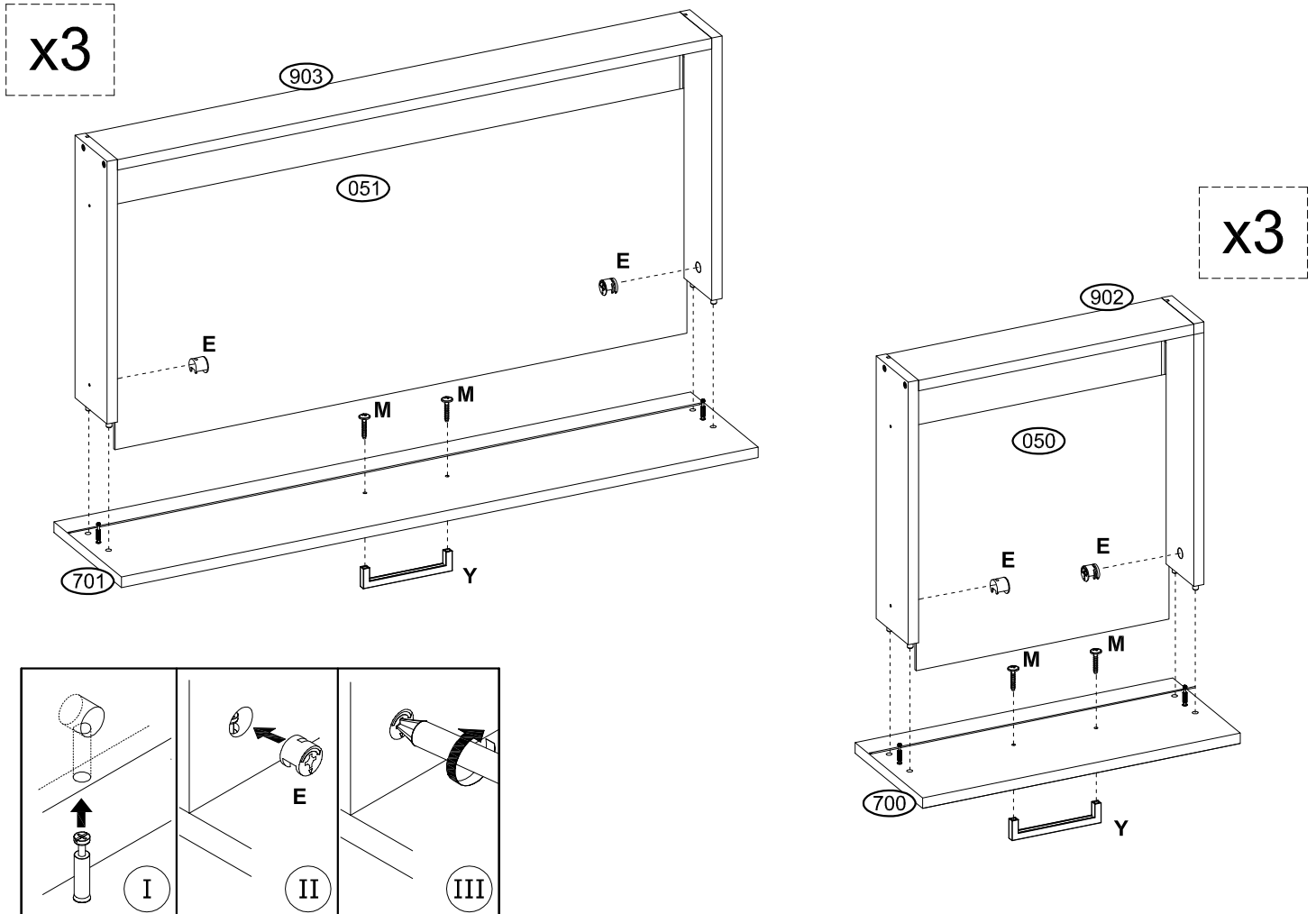

30

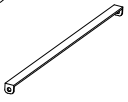
<b>L</b> Ø3,5x16 mm  x6 3918	<b>A1</b> 384 mm  x3 69509	 
---	--	--

x3

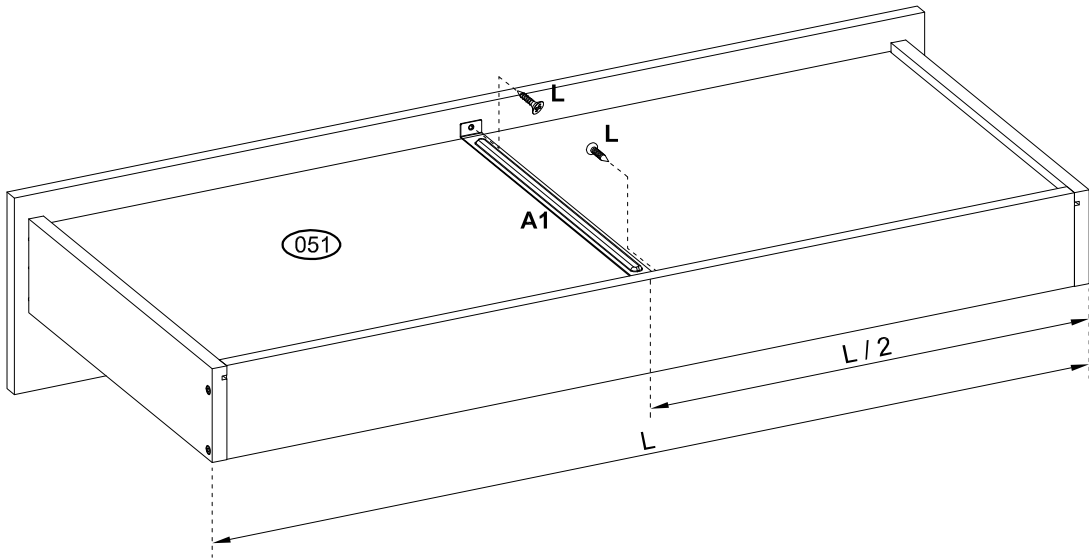

31

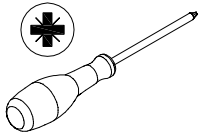
<b>L</b> Ø3,5x16 mm  x24 3918	<b>W</b> 400x27 mm  x6 252763	
--	--	--

x3

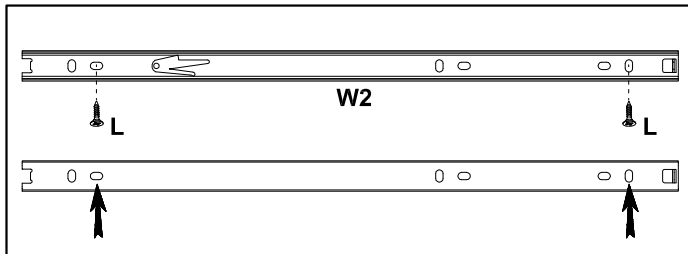
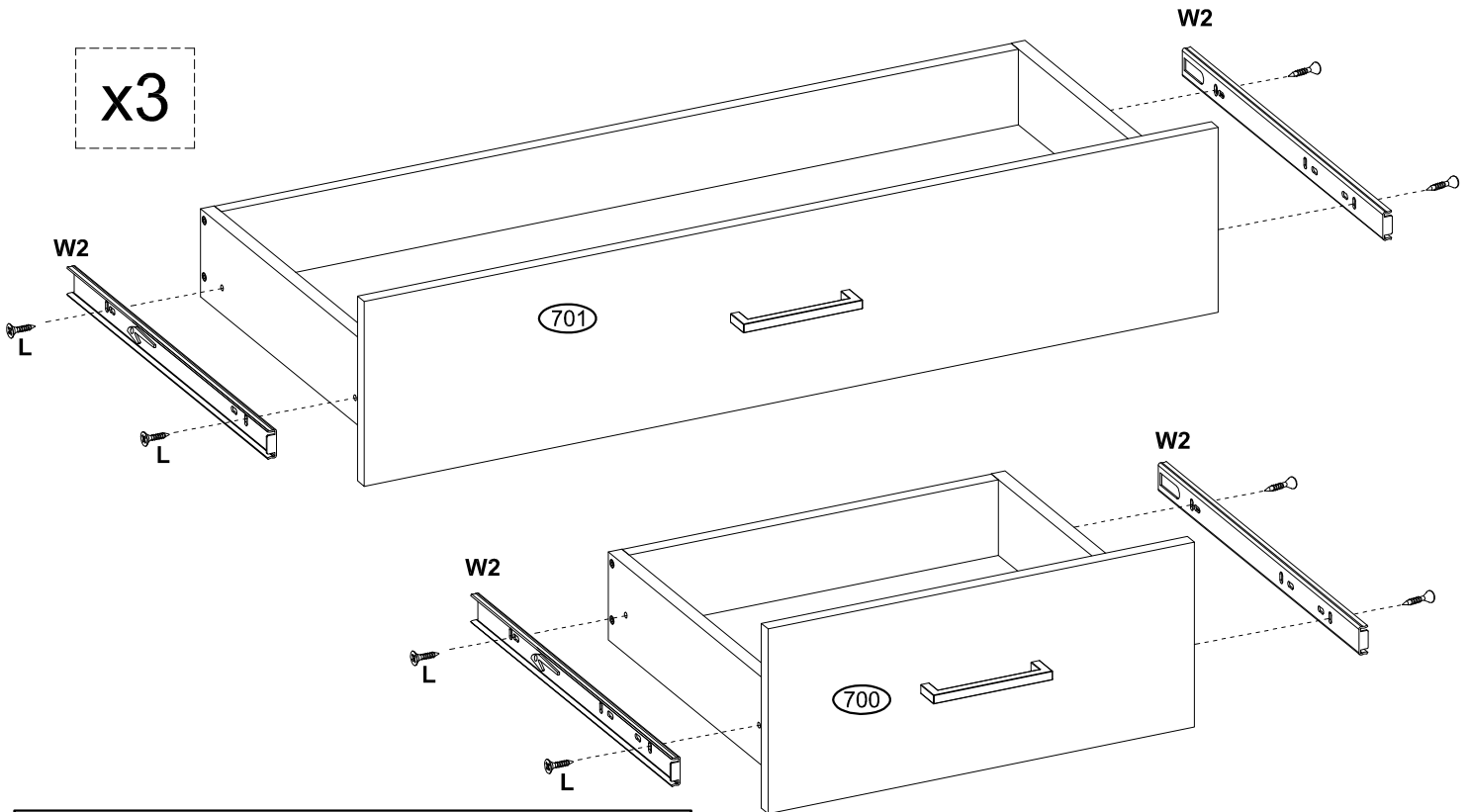

# 32

<b>L</b>	Ø3,5x16 mm	<b>M</b>	Ø4x25 mm	<b>X</b>	Ø35 mm , KR8	<b>Y</b>	138 mm	
	x12 3918		x4 145556		x6 67350		x2 167314	

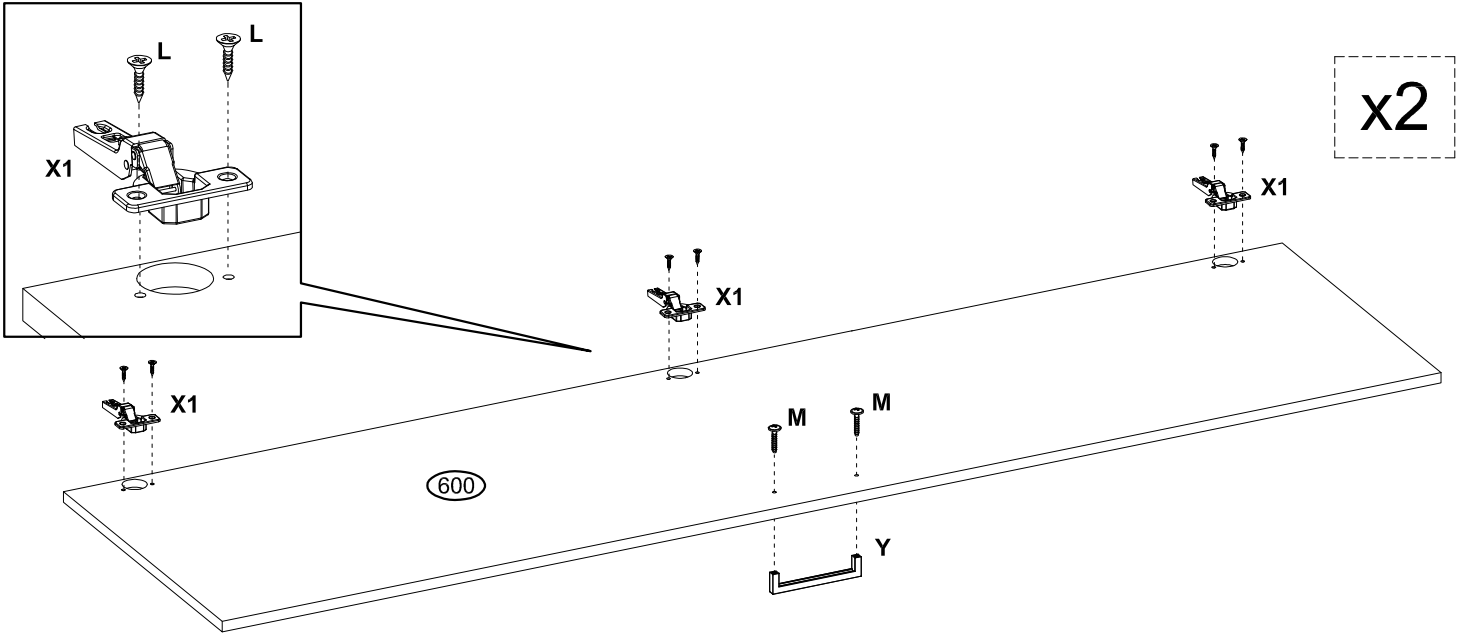

# 33

<b>L</b>	Ø3,5x16 mm	<b>X</b>	Ø35 mm , KR8		Ø5 mm	
	x18 3918		x9 67350			

x3

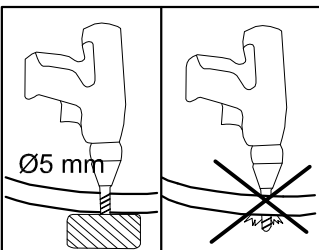
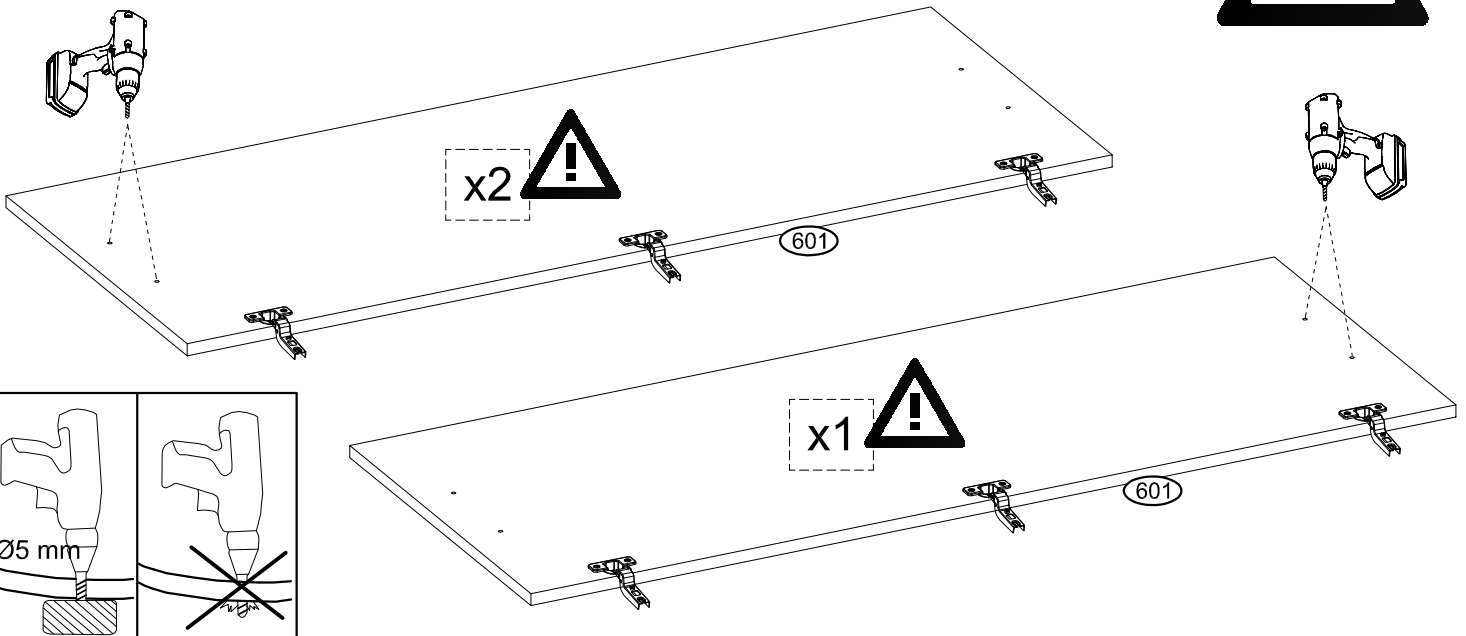
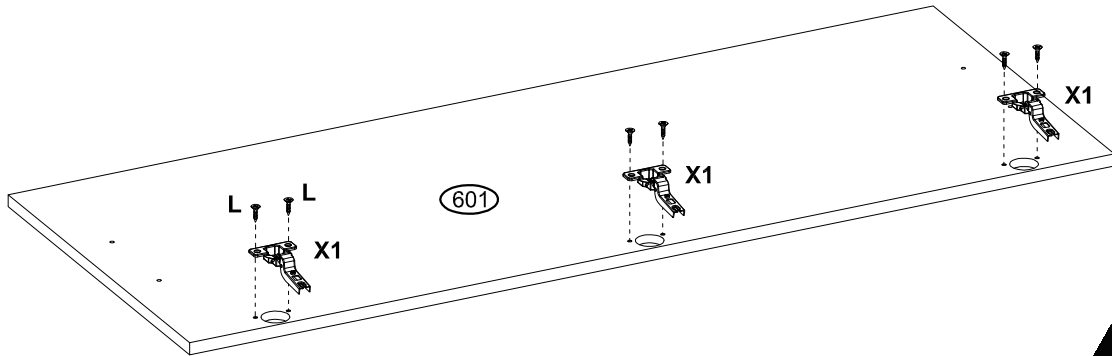

34

<b>M</b> Ø4x25 mm  x6 145556	<b>Y</b> 138 mm  x3 167314	 
---	--	--

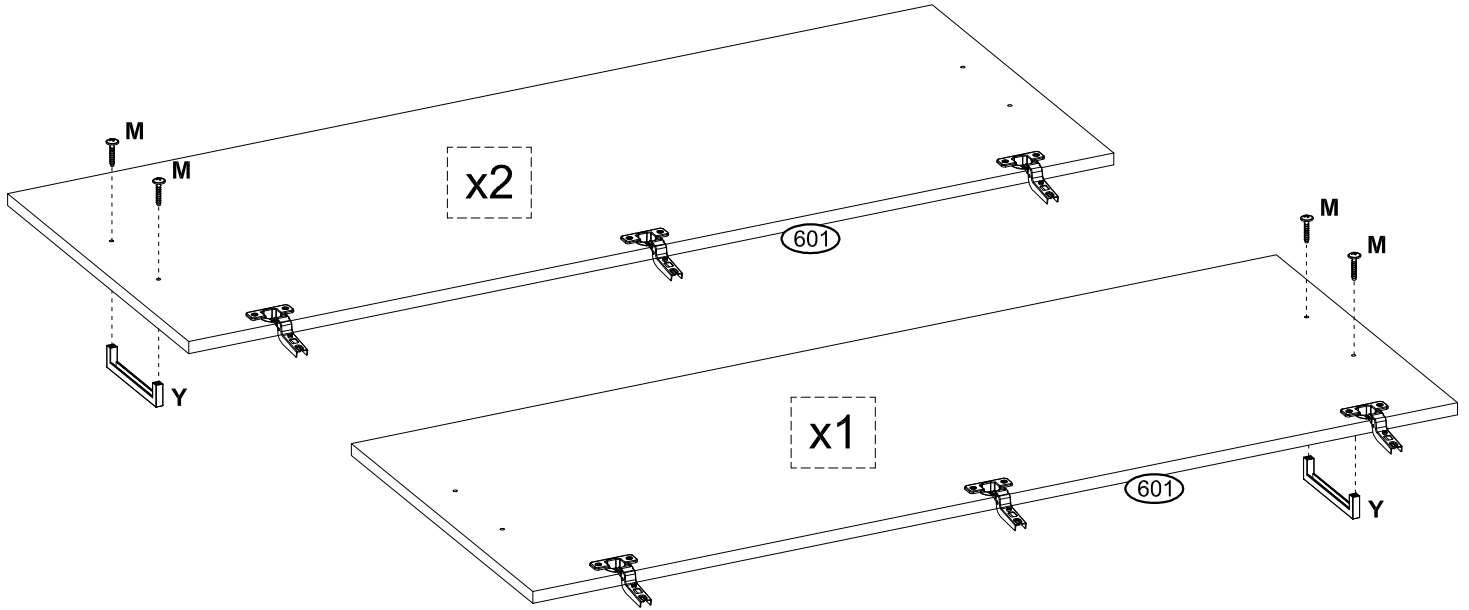

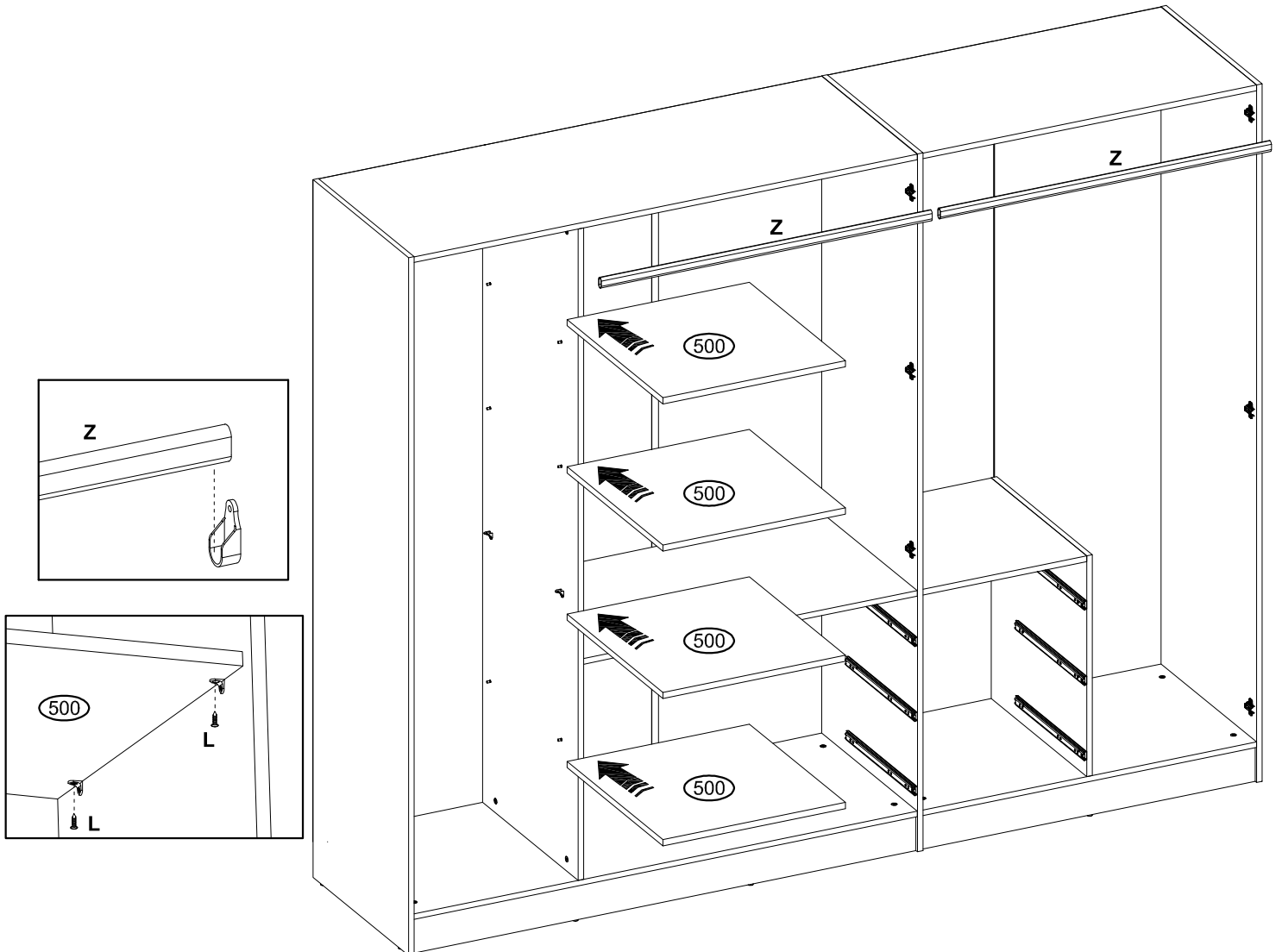

35

<b>L</b> Ø3,5x16 mm  x4 3918	<b>Z</b> 969 mm  x2 83086	 
---	---	---

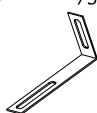

# 36

<b>H</b>	75x15x32 mm	<b>L</b>	Ø3,5x16 mm
	x2 71900		x4 3918

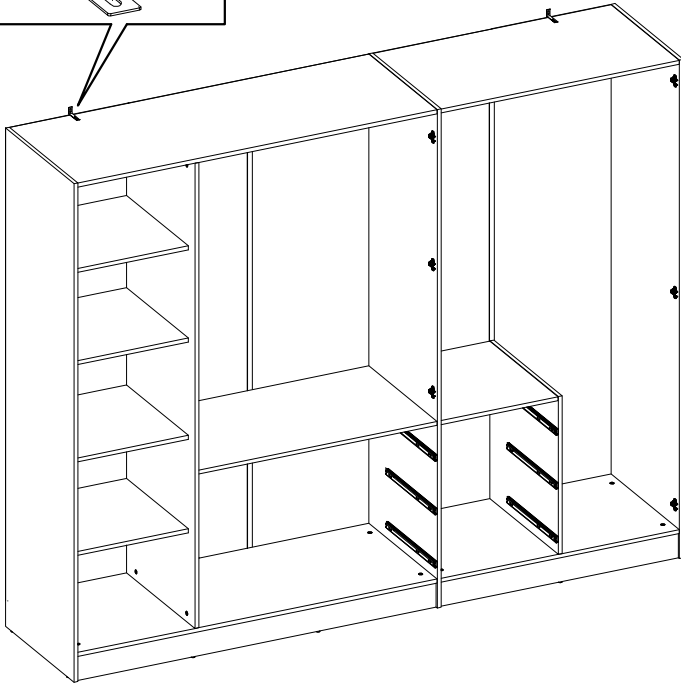
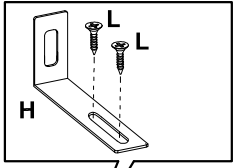
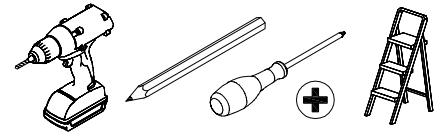

**ACHTUNG!** - ATTENTION! - ATTENTION! - ATTENZIONE! - LET OP! - UWAGA! - POZOR! - FIGYELEM! - ATENȚIE! - ДІККАТ! - ВНИМАНИЕ! - ПРИМЕДА! - НАПОМЕНА! - POZOR! - DĚMESIO! - PIEŽĪME! - MĀRKUS!

- D - ACHTUNG:** WARNUNG Umkippen zu vermeiden, muss dieses Produkt mit der mitgelieferten Wandhalterung verwendet werden.
- GB - WARNING:** WARNING In order to prevent overturning this product must be used with the wall attachment device provided.
- FR - REMARQUE:** AVERTISSEMENT Pour éviter le renversement, ce produit doit être utilisé avec le support de montage mural fourni.
- IT - NOTA:** AVVERTENZA Per evitare il ribaltamento, questo prodotto deve essere utilizzato con una staffa di montaggio a parete inclusa.
- NL - OPMERKING:** WAARSCHUWING Om kantelen te voorkomen, moet dit product worden gebruikt met de meegeleverde wandmontagebeugel.
- PL - UWAGA:** OSTRZEŻENIE Aby zapobiec przewróceniu, produkt ten musi być używany z dołączonym uchwytem do montażu ściennego.
- CZ - POZNÁMKA:** UPOZORNĚNÍ Aby se zabránilo převrácení, musí být tento výrobek používán s dodaným držákem pro montáž na stěnu.
- SK - OPOMBA:** OPOZORILO Da bi preprečili prevračanje, je treba ta izdelek uporabljati s priloženim nosilcem za pritrjevanje na steno.
- HU - MEGJEGYZÉS:** FIGYELMEZTETÉS A billenés megakadályozása érdekében ezt a terméket a mellékelt fali rögzítő konzollal kell használni.
- RO - NOTĂ:** AVERTISMENT Pentru a preveni răsturnarea, acest produs trebuie să fie utilizat cu suportul de montare pe perete furnizat.
- TR - NOT:** UYARI Devrilmeyi önlemek için, bu ürün biriktire verilerin duvarla montaj braketi ile kullanılmalıdır.
- RU - ПРИМЕЧАНИЕ:** ПРЕДУПРЕЖДЕНИЕ Для предотвращения опрокидывания, этот продукт необходимо использовать с прикрепленным кронштейном для настенного монтажа.
- SRB - НАПОМЕНА :** УПОЗОРЕЊЕ Да бисте спречили превртање, овај производ мора да се користи са укљученом зидним заградом за монтажу.
- HR - NAPOMENA:** UPOZORENJE Da biste spriječili prevrtanje, ovaj se proizvod mora koristiti s priloženim zidnim nosačem.
- SL - POZNÁMKA:** UPOZORNENIE Aby sa zabránilo prevráteniu, tento výrobok sa musí používať s dodanou nástennou montážnou konzolou.
- LT - PASTABA:** ĮSPĖJIMAS Kad šis gaminyas neapvirštu, jis turi būti naudojamas su pridėdamu sieniniu laikikliu.
- LV - PIEŽĪME:** BRĪDINĀJUMS Lai novērstu apgāšanos, šis izstrādājums jāizmanto kopā ar pievienoto sienas stiprinājuma kronšteinu.
- EE - MÄRKUS:** HOIATUS Kukkumise vältimiseks tuleb seda toodet kasutada koos kaasasoleva seinakinnitusklaambriga.

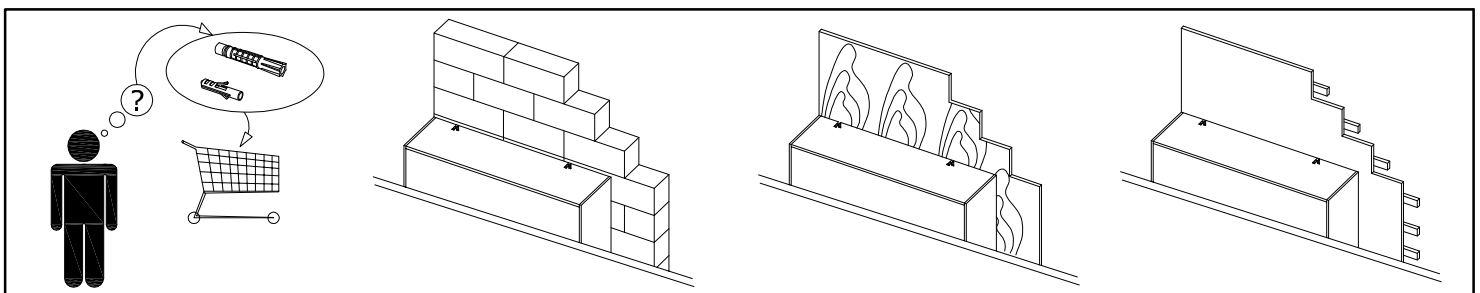
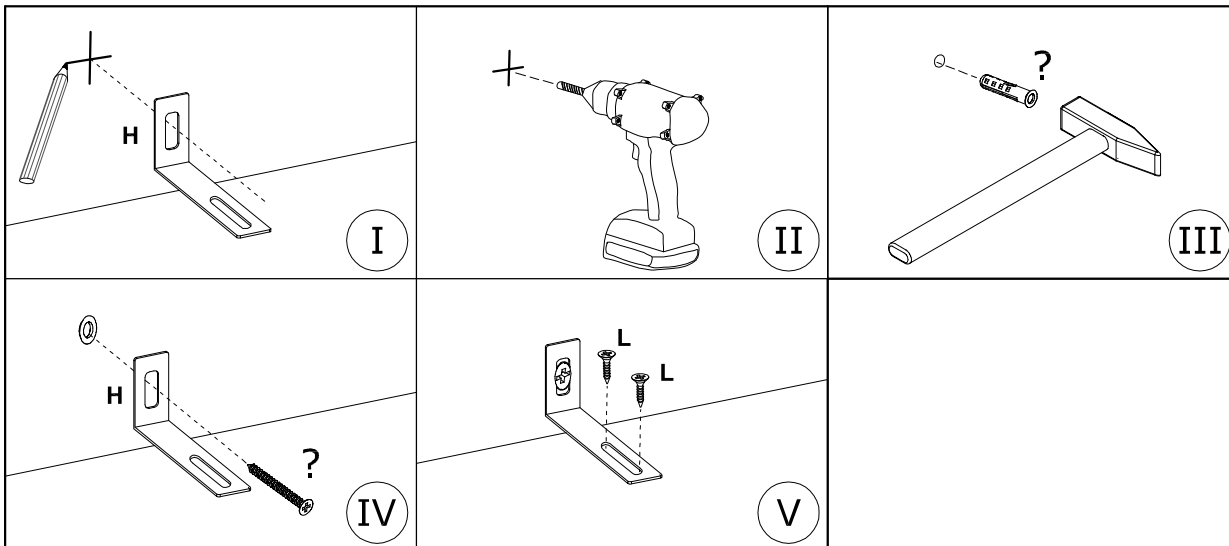

37

L	Ø3,5x16 mm		x12	3918	
---	------------	---	-----	------	--

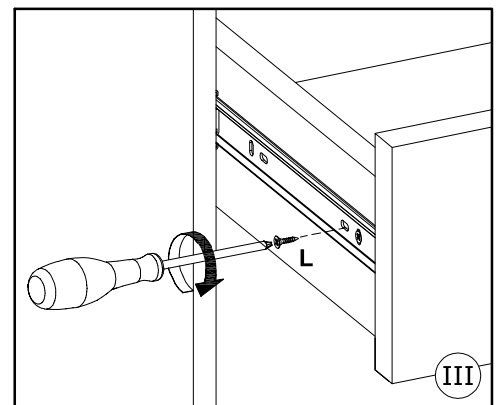
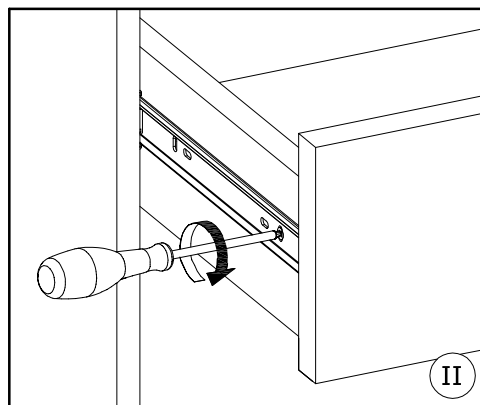
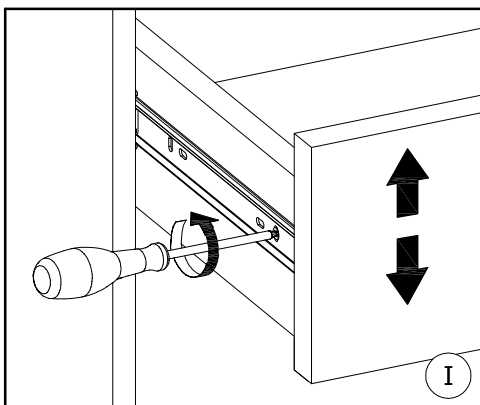
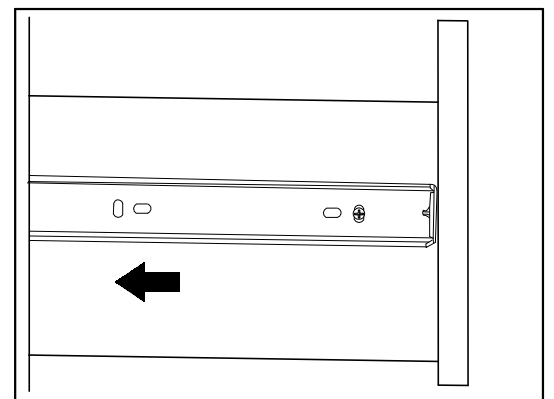
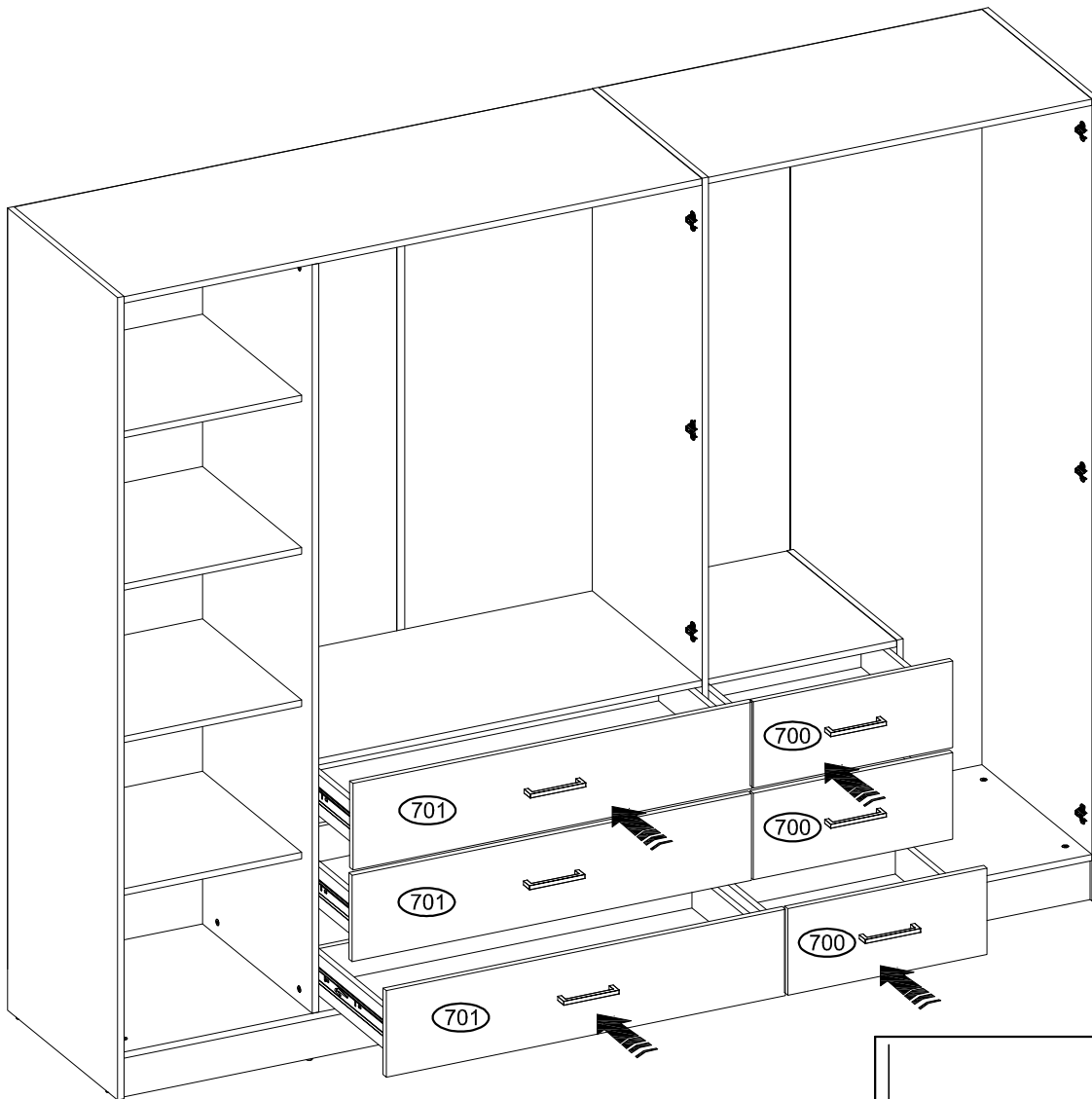

38

<b>F</b>	Ø20 mm		
	x28		
	136239		

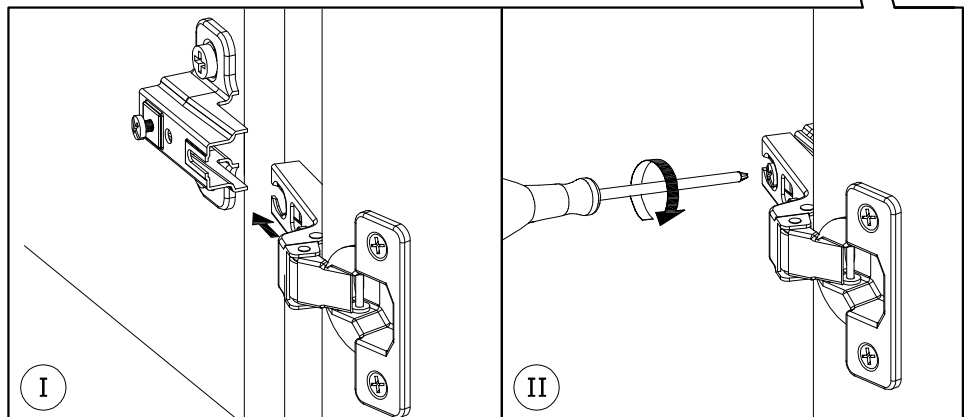
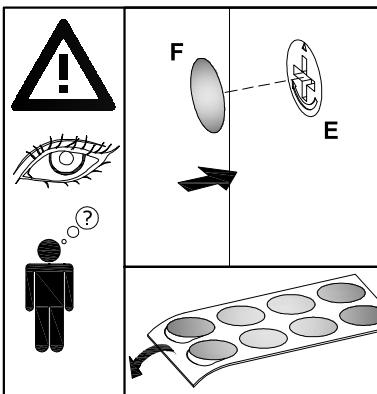
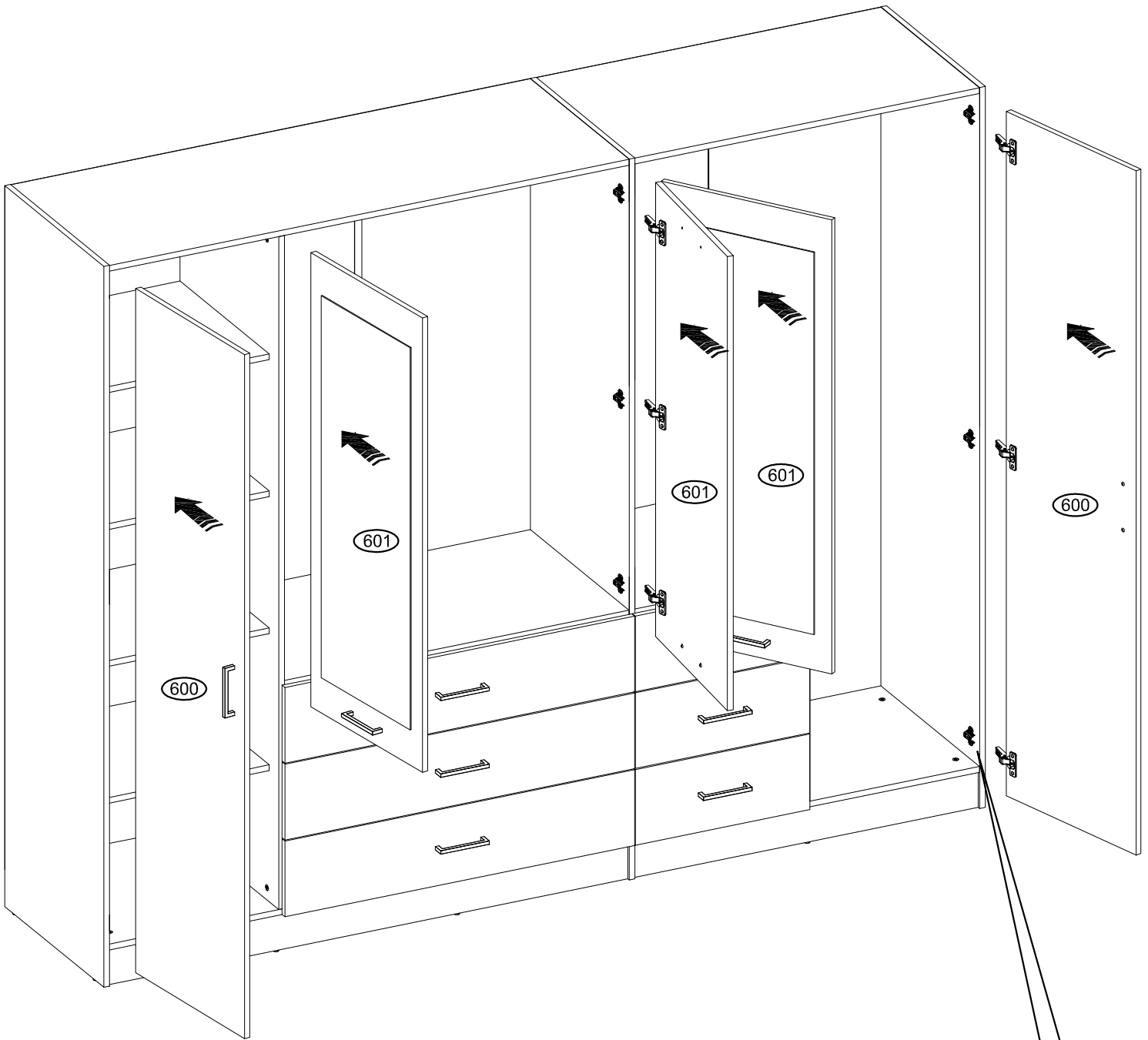

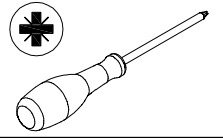

**Türen einstellen (Scharniere justieren)**  
 Adjusting the door (adjusting the hinges)  
**Régler les portes (ajuster les charnières)**  
 Sistemare le porte (regolare le cerniere)  
**Deuren instellen (scharnieren afstellen)**  
 Nastawić drzwi (wyregulować zawiasy)  
**Vyrovnaťte dvířka (seřid'te závěsy)**  
 Nastavenie dverí (nastavenie závesov)  
**Állítsa be az ajtókat (állítsa be a zsanérokot)**

**Reglare uși (ajustare balamale)**  
**Kapilarin ayarlanması (menteşelerin seviye ayarı)**  
 Регулировка дверей (регулировка шарнира)  
**Поставите врата (подесите шарке)**  
 Postavite vrata (podesite šarke)  
**Nastavenie dverí (nastavenie závesov)**  
 Sureguliuokite duris (sureguliuokite vyrius)  
**Pielāgojiet durvis (noregulējiet eņģes)**  
 Reguleeri uks (reguleeri hinged)

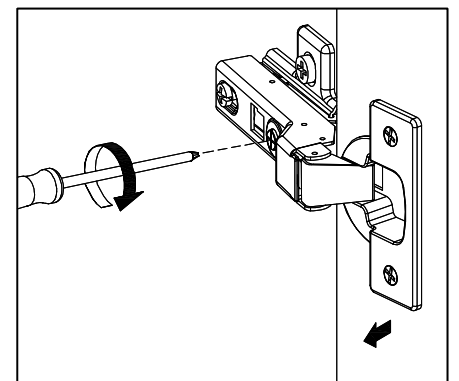
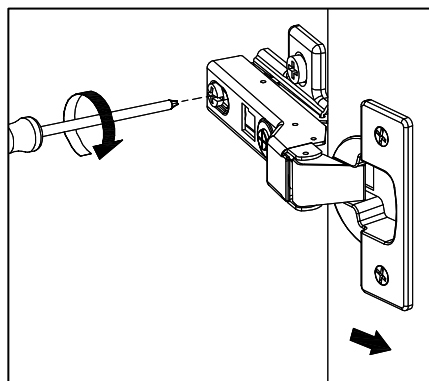
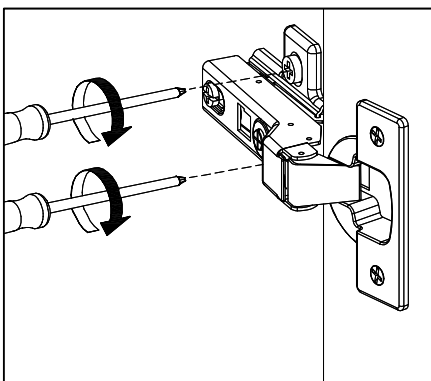
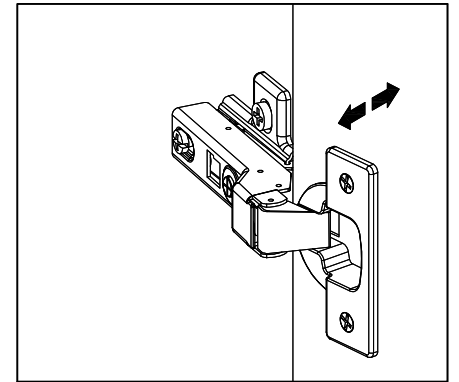
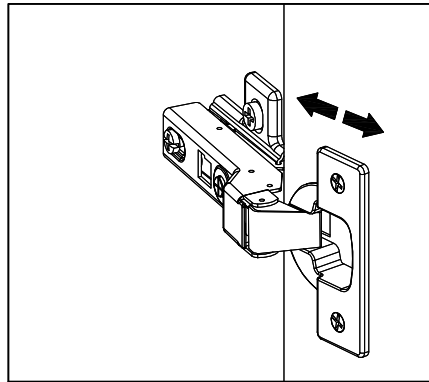
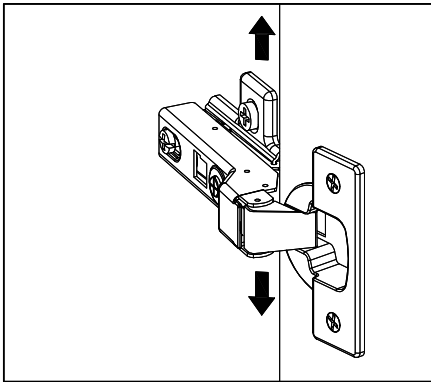
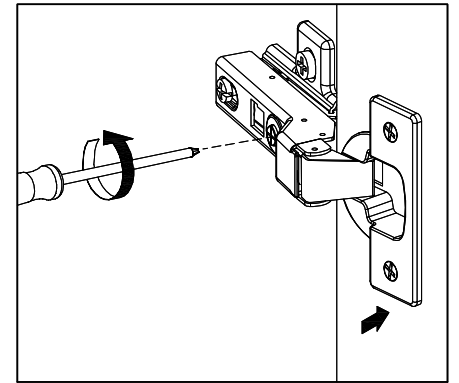
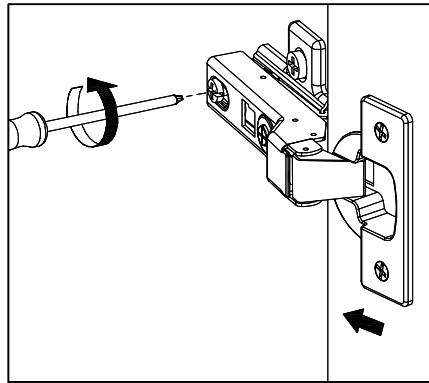
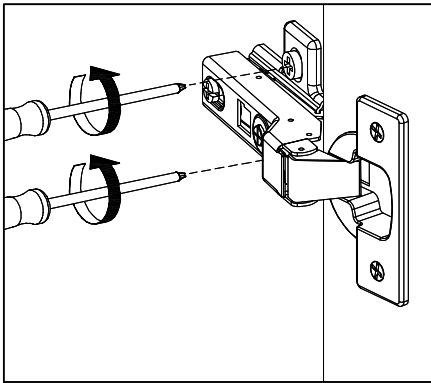
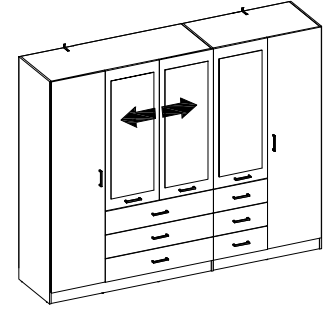
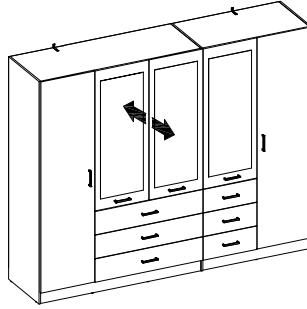
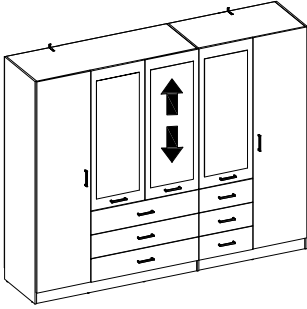

- D** Sicherheits- und Pflegehinweise
- FR** Conseils de sécurité et d'entretien
- NL** Veiligheids- en onderhoudstips
- CZ** Tipy pro bezpečnost a údržbu
- HU** Biztonsági és karbantartási tanácsok
- TR** Güvenlik ve bakım ipuçları
- ES** Instruções de segurança e manutenção
- SRB** Савети за безбедност и одржавање
- SL** Nasveti za varnost in vzdrževanje
- LV** Drošības un apkopes padomi

- GB** Safety and maintenance tips
- IT** Consigli per la sicurezza e la manutenzione
- PL** Wskazówki dotyczące bezpieczeństwa i konserwacji
- SK** Tipy na bezpečnosť a údržbu
- RO** Sfaturi de siguranță și întreținere
- RU** Советы по безопасности и обслуживанию
- PT** Instruções de segurança e manutenção
- HR** Savjeti za sigurnost i održavanje
- LT** Saugos ir priežiūros patarimai
- EE** Ohutus- ja hooldusnõuanded

