

TEJO 013

- PL** Instrukcja montażu
CZ Instrukce k instalaci
D Montageanleitung
GB Assembly instruction
F Midel d'emploi
HU Szerelési útmutató
I Istruzione di montaggio
NL Handleiding voor de montage
RU Инструкция по установке
RO Instructiuni de instalare
SK Návod na inštaláciu
TR Montaj talimatı
SE Monteringsinstruktion
SLO Navodila za namestitev
HR Upute za sastavljanje

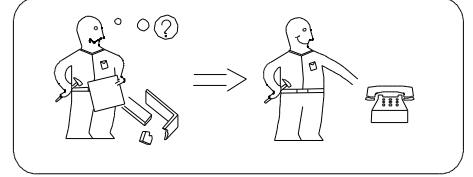
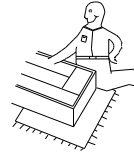
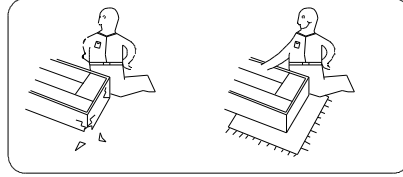
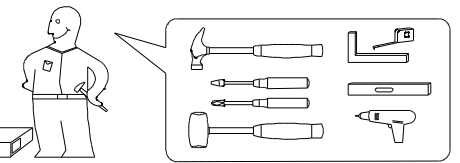
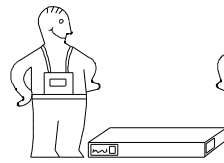

!
Uwaga . Upozornini. Achtung . Attention . Caution . Firyelem . Attenzione . Orgelet . Внимание . Atentie . Upozornenie . Dikkat . Uppmärksamhet . Uppmärksamhet . Pozor . Pažnja
!

PL	Czyszczenie należy wykonywać wyłącznie za pomocą ściereczki lekko nawilżonego ręcznika. nie stosować środków czyszczących do szorowania.	I	La pulizia deve essere eseguita solo con un panno e un asciugamano leggermente inumidito. non utilizzare agenti abrasivi.
CZ	Čištění í by se m ělo prov ádět pouze hadř íkem a mírn ě navlhčen ým ru čníkem. nepou žívejte abrazivní prost ředky.	NL	Reinig alleen met een stofdoek of lichtjes met een vochtige doek. Gebruik geen schurende of bijtende poetsmiddelen.
D	Bitte nur mit einem Staubtuch oder leicht feuchtem Lappen reinigen. Keine scheuernden Putzmittel verwenden.	RU	Чистку следует производить только тряпкой, слегка смоченной полотенцем. не используйте чистящие средства.
GB	Please only clean with a duster or a damp cloth. Do no use any abrasive cleaners.	RO	Curatare trebuie efectuata numai cu o carpa sau cu un prosop usor umezit. Nu utilizati agenti de curatare abrazivi.
F	Le nettoyage doit être effectué uniquement avec un chiffon, une serviette légèrement humidifiée. n'utilisez pas d'agents à récurer.	SK	Čistenie by sa malo uskutočňovať iba pomocou handričky a mierne navlhčen ého uteráka. nepou žívajte drsné prostriedky.
HU	A tisztítást csak ruhával, enyhén megnedvesített törülköz ővel szabad elv égezni. ne használjon tisztítószer t a súroláshoz.	TR	Temizlik sadece bezle, hafif çe nemlendirilmi ş havluyla yapılmalıdır. ovma maddeleri kullanmayın.
SE	Torka rent med en fuktig trasa. Använd endast vatten eller ett mildt rengöringsmedel. Torka torrt med en ren trasa.	SLO	Obršite z vlažno krpo. Uporabljajte le vodo ali blag detergent. Posušite s čisto krpo.
HR	Očistite vlažnom krpom. Upotrijebite samo vodu ili blagi deterđent. Posušite čistom krpom.		



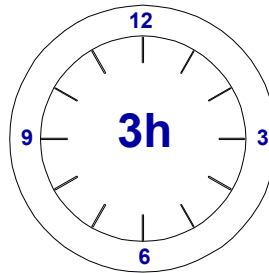
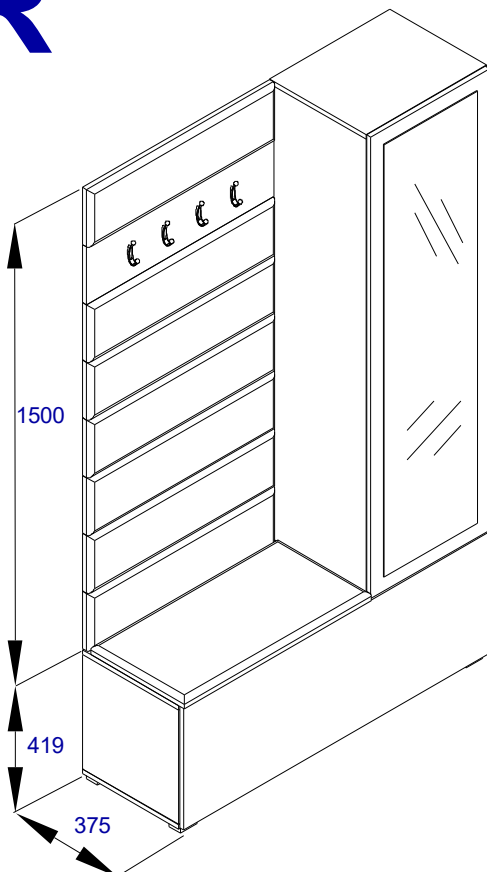

R

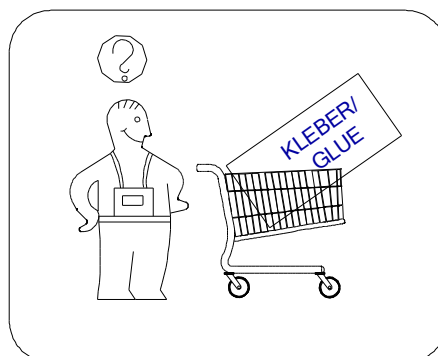
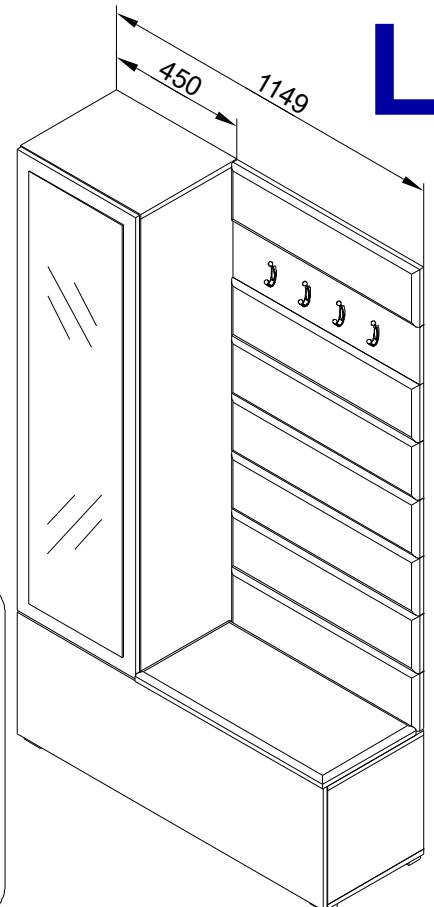







L



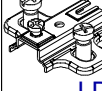

I - IV

					4x30
A	B	D	S	G	H1
12x	16x	16x	16x	2x	4x

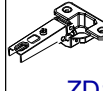



V - X

			4x22					3x13		4x16
A	LD	M	H14	S	D	B	Q	H	ZD1	H8
12x	2x	5x	10x	x4	8x	8x	2x	6x	5x	10x

XI - XXI

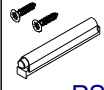
4x22		3x13	
H18	ZT	H	I
8x	4x	x6	16x

XXII - XXIV

			4x22			
LD	PS	X3	H14	KR	KR1	KR2
3x	2x	26x	3x	2x	x6	x2

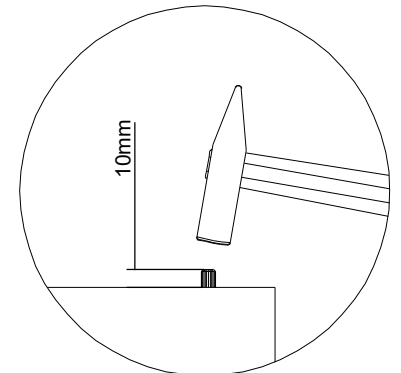
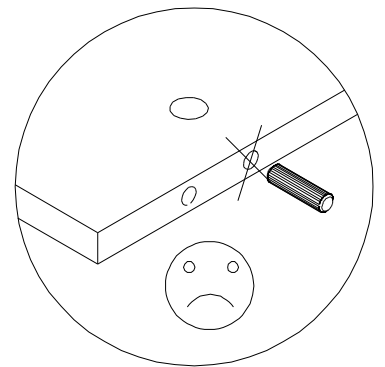
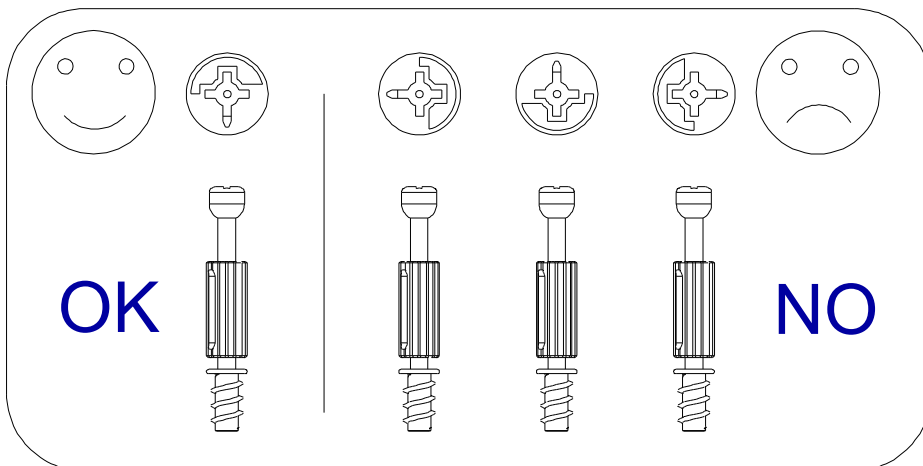

TEJO 013

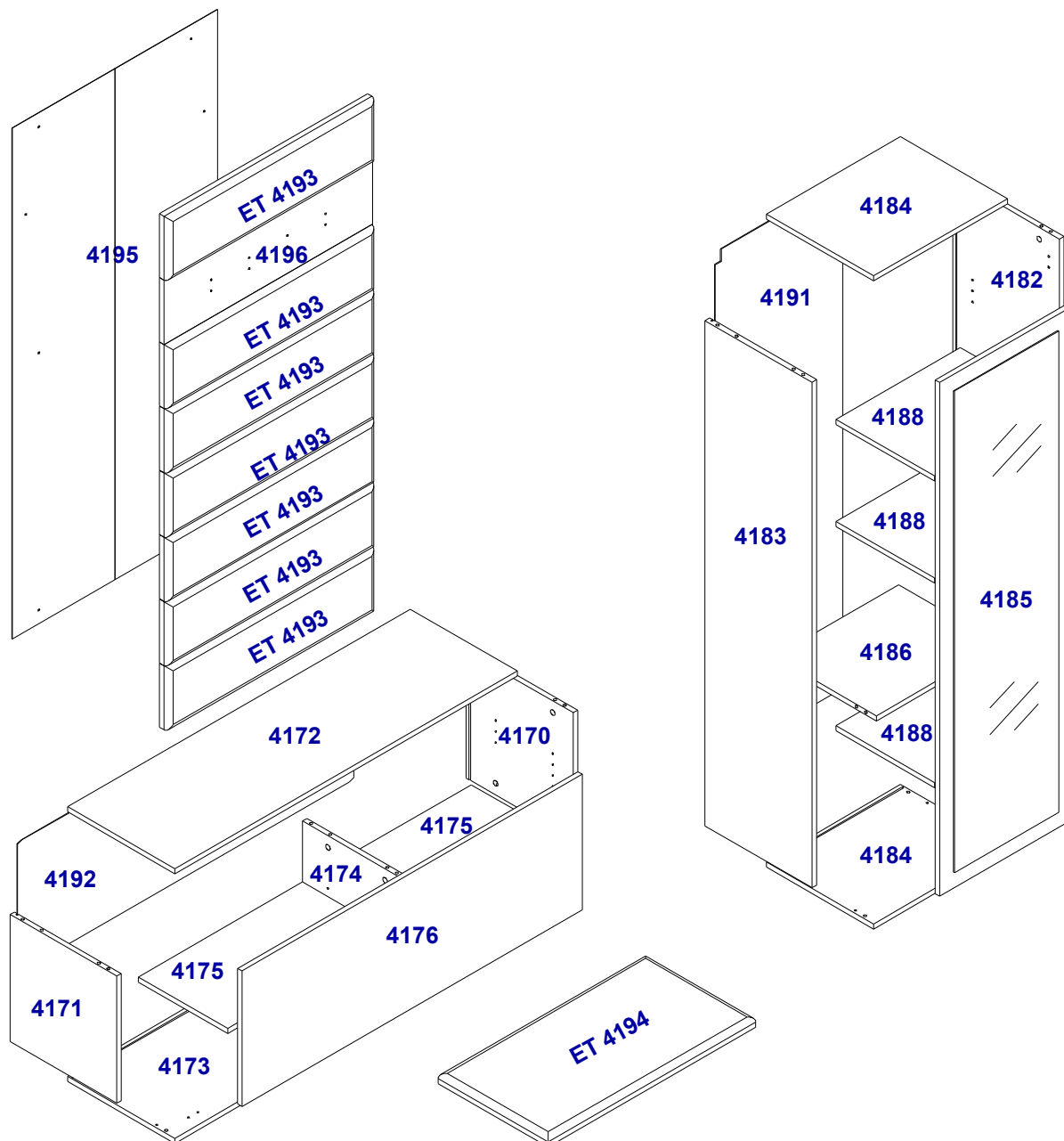
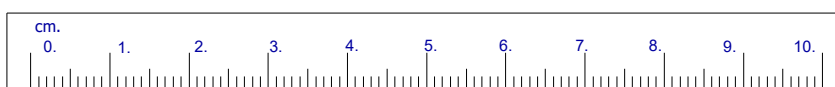
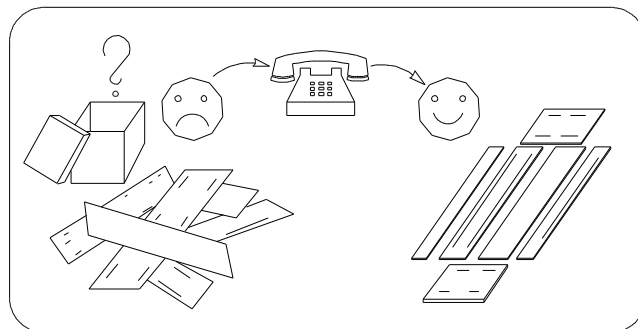
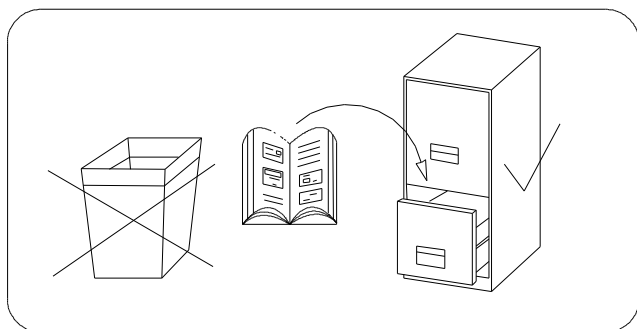

I

x2

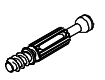

A
8x

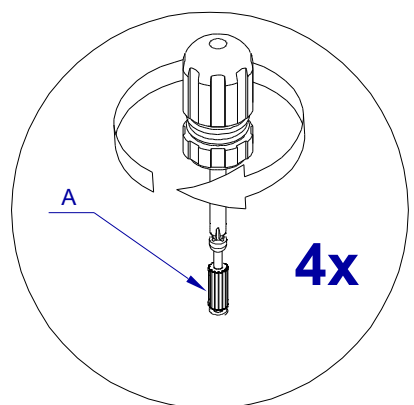
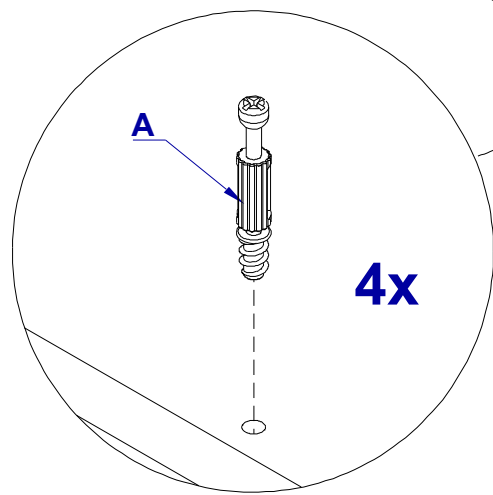
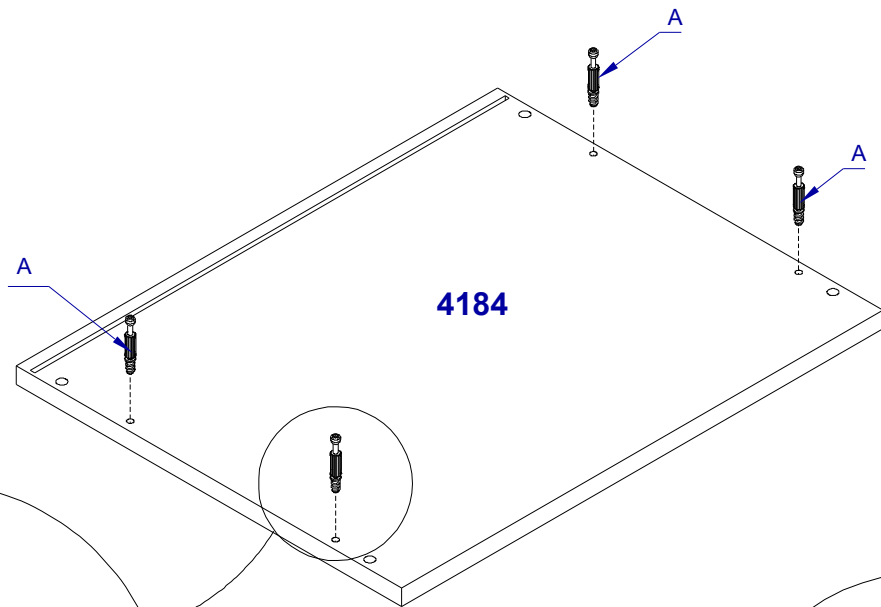

II

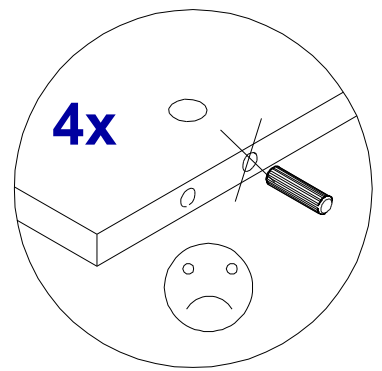
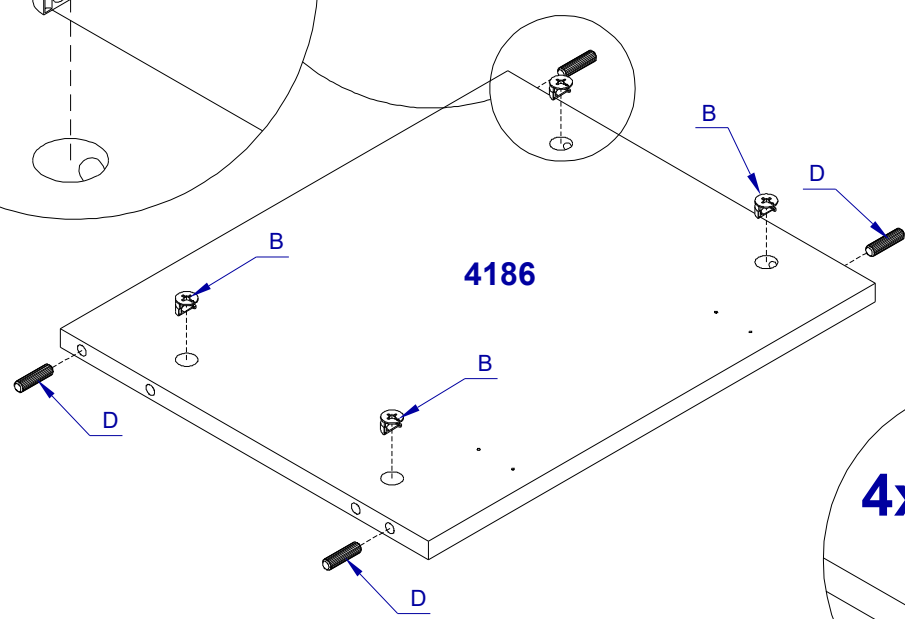
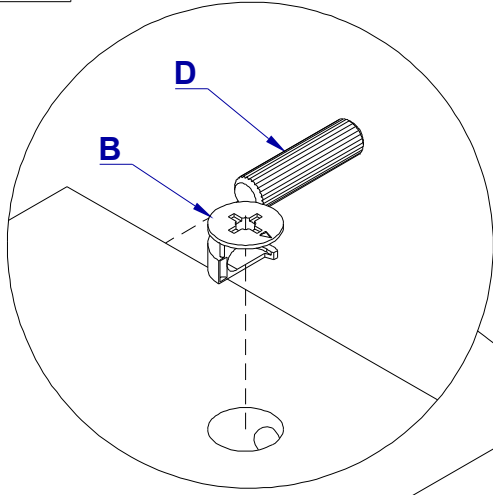
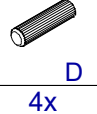
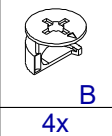



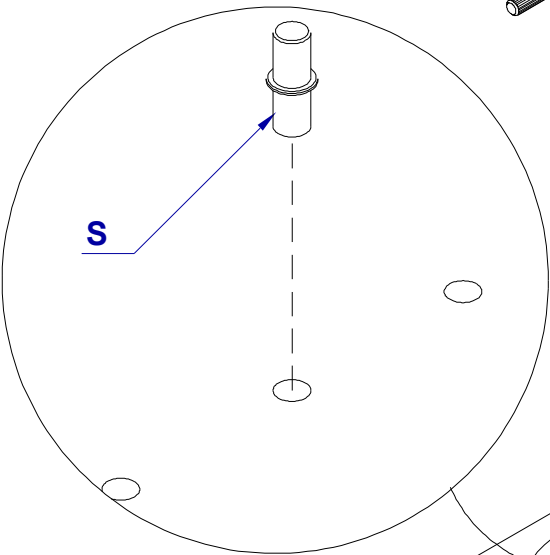
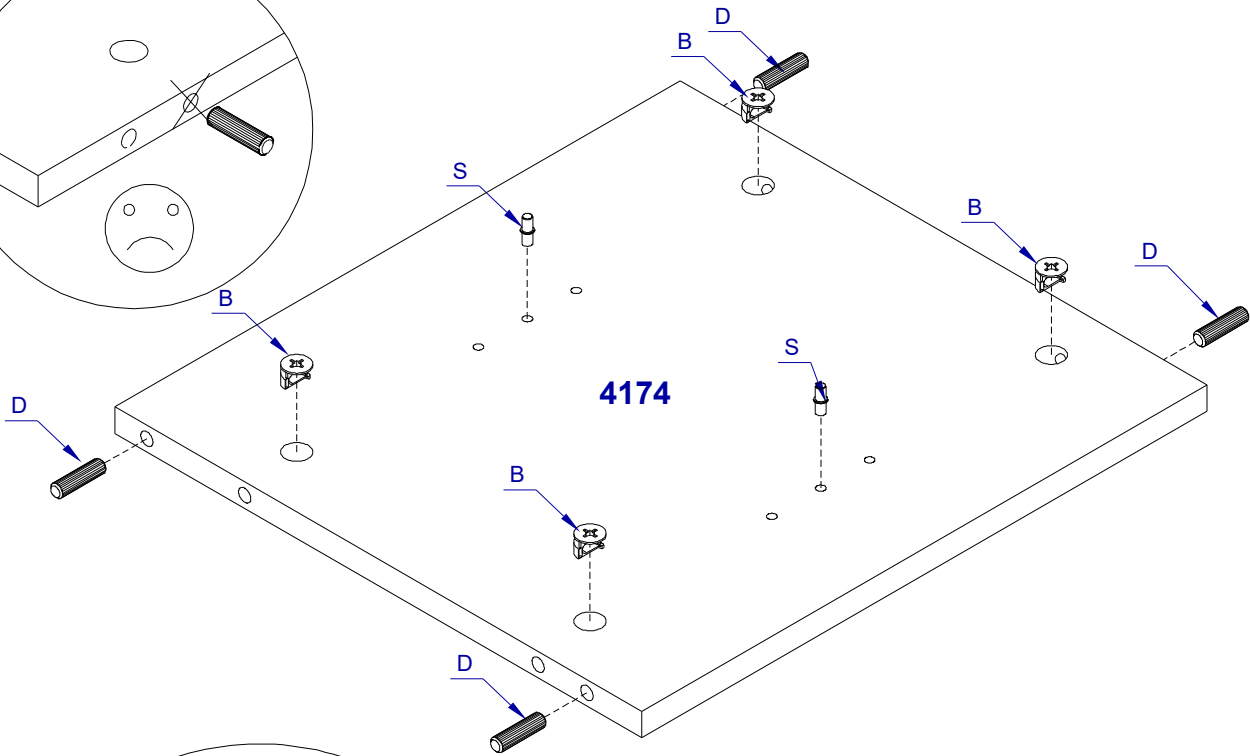
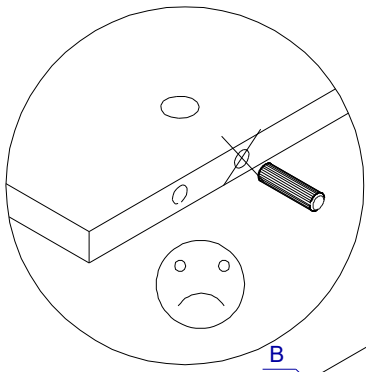

S	B	D
x4	4x	4x



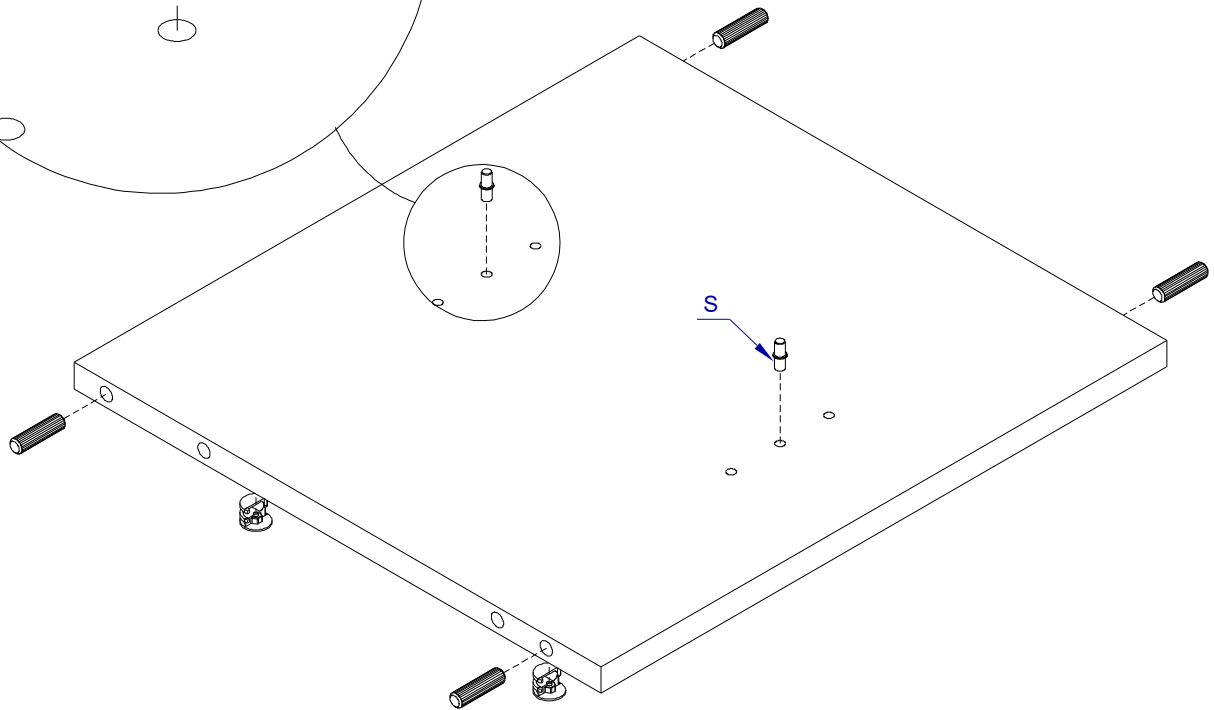

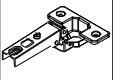

180°

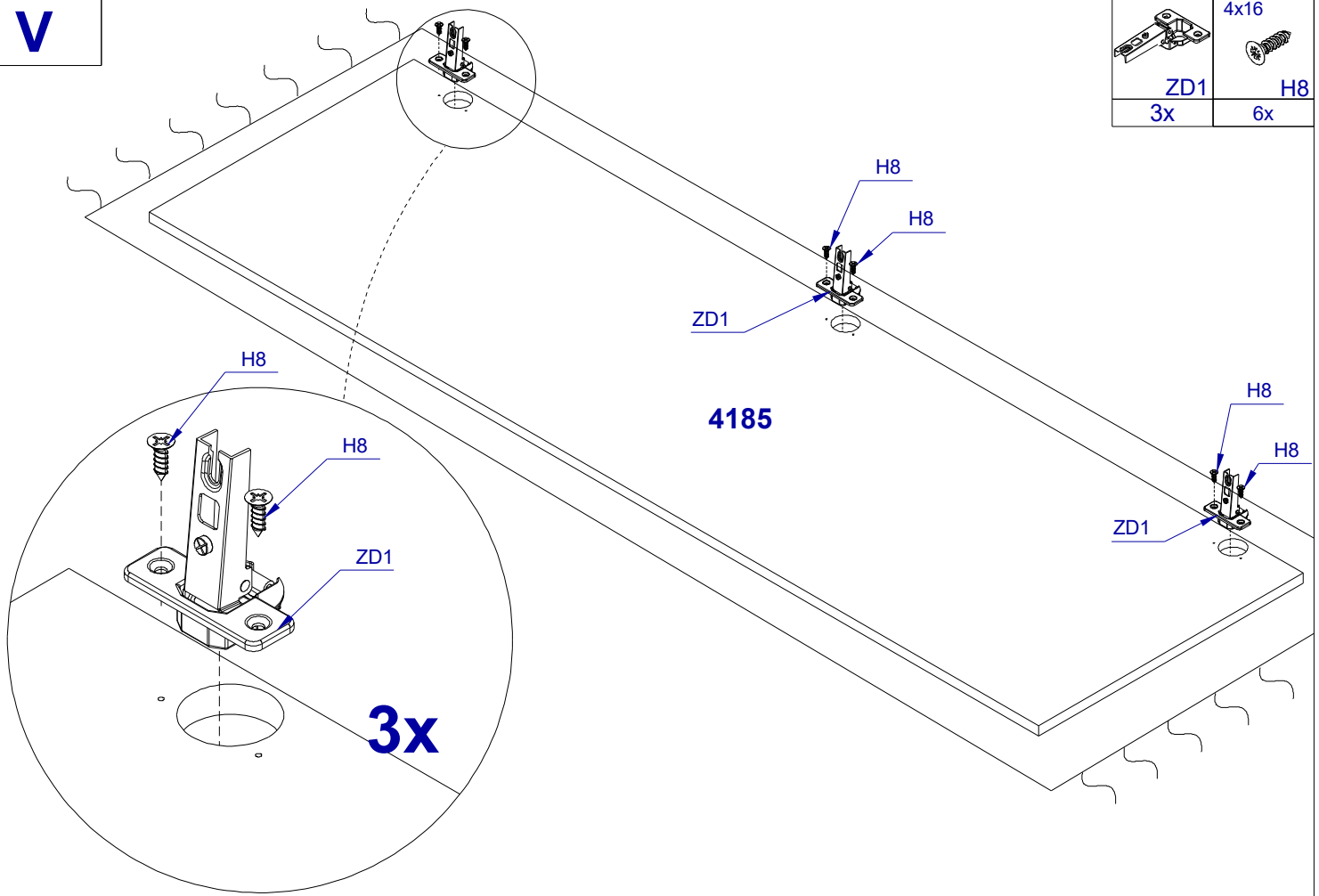

V

	4x16
	H8
ZD1	H8
3x	6x

**VI**

				3x13
S	D	B	Q	H
x2	4x	4x	1x	3x

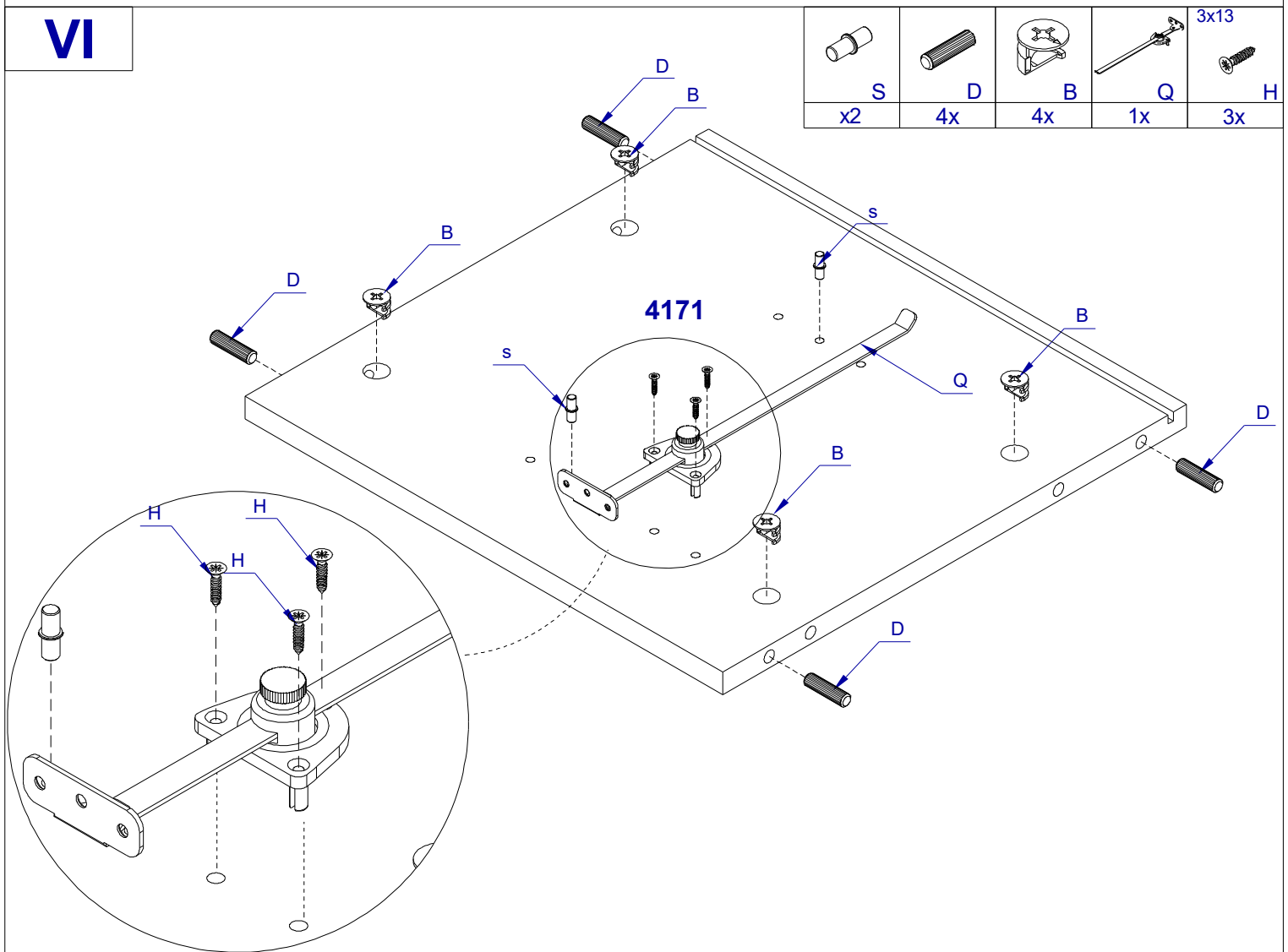

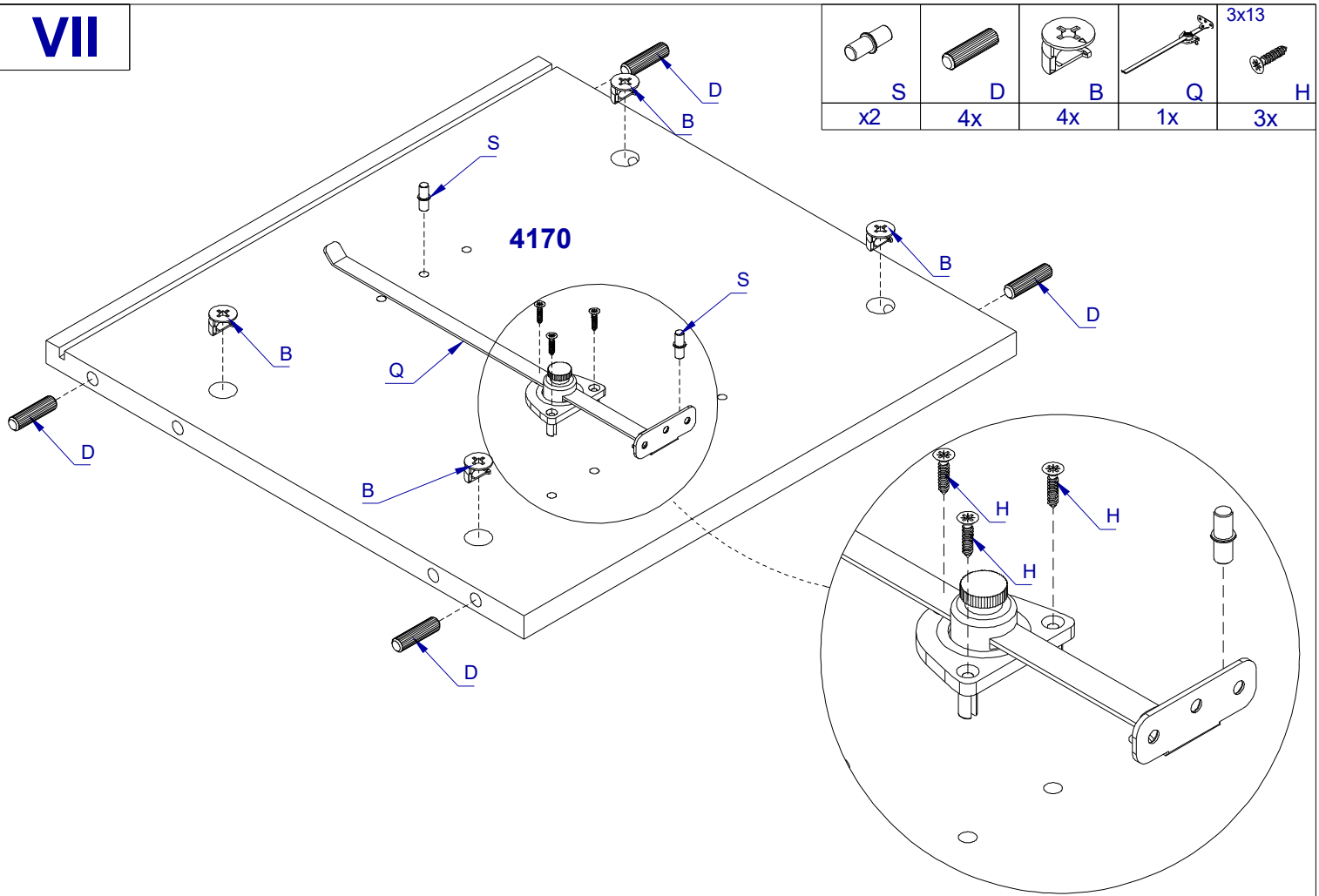

VII

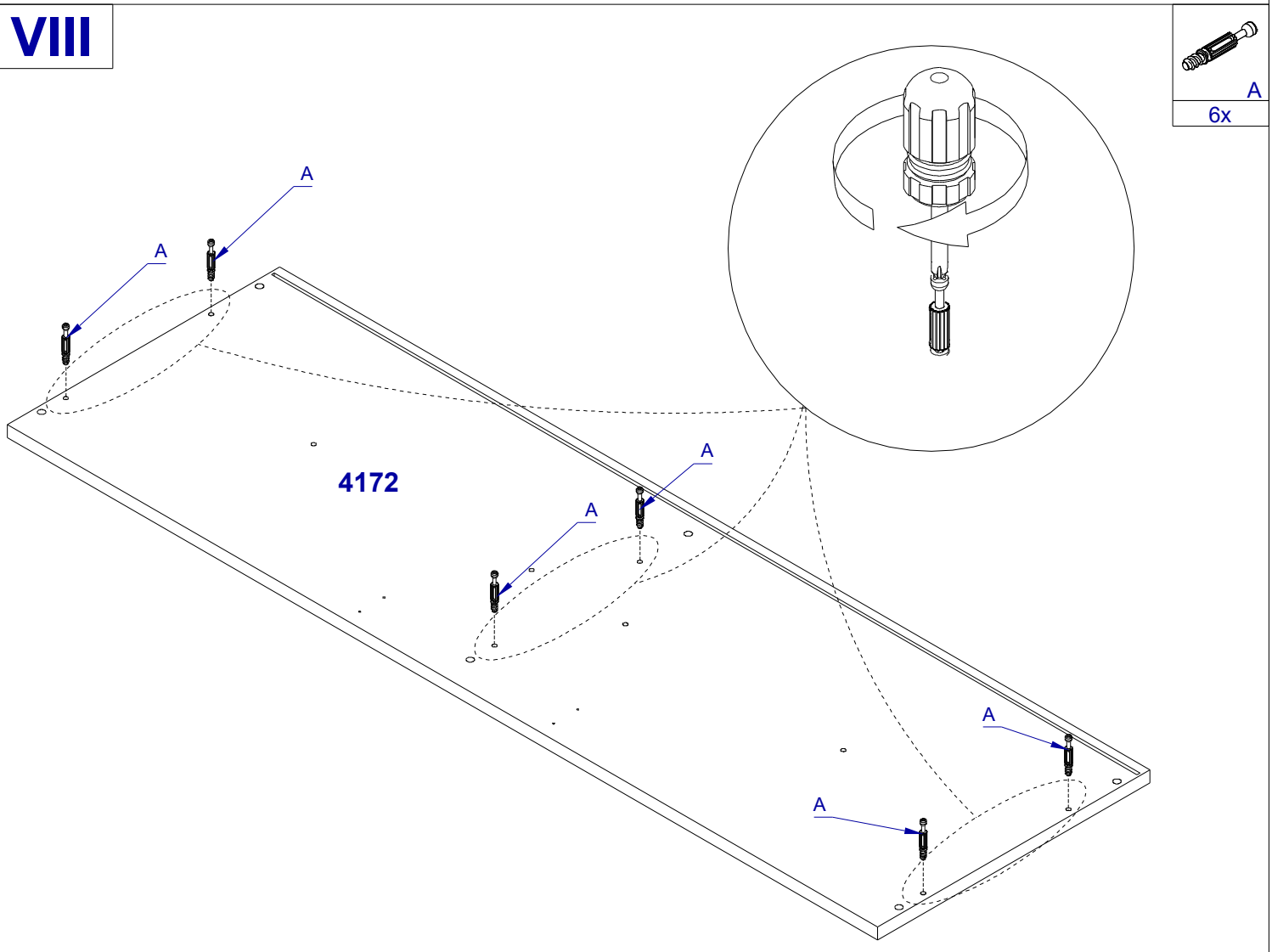

VIII



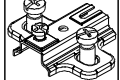

IX

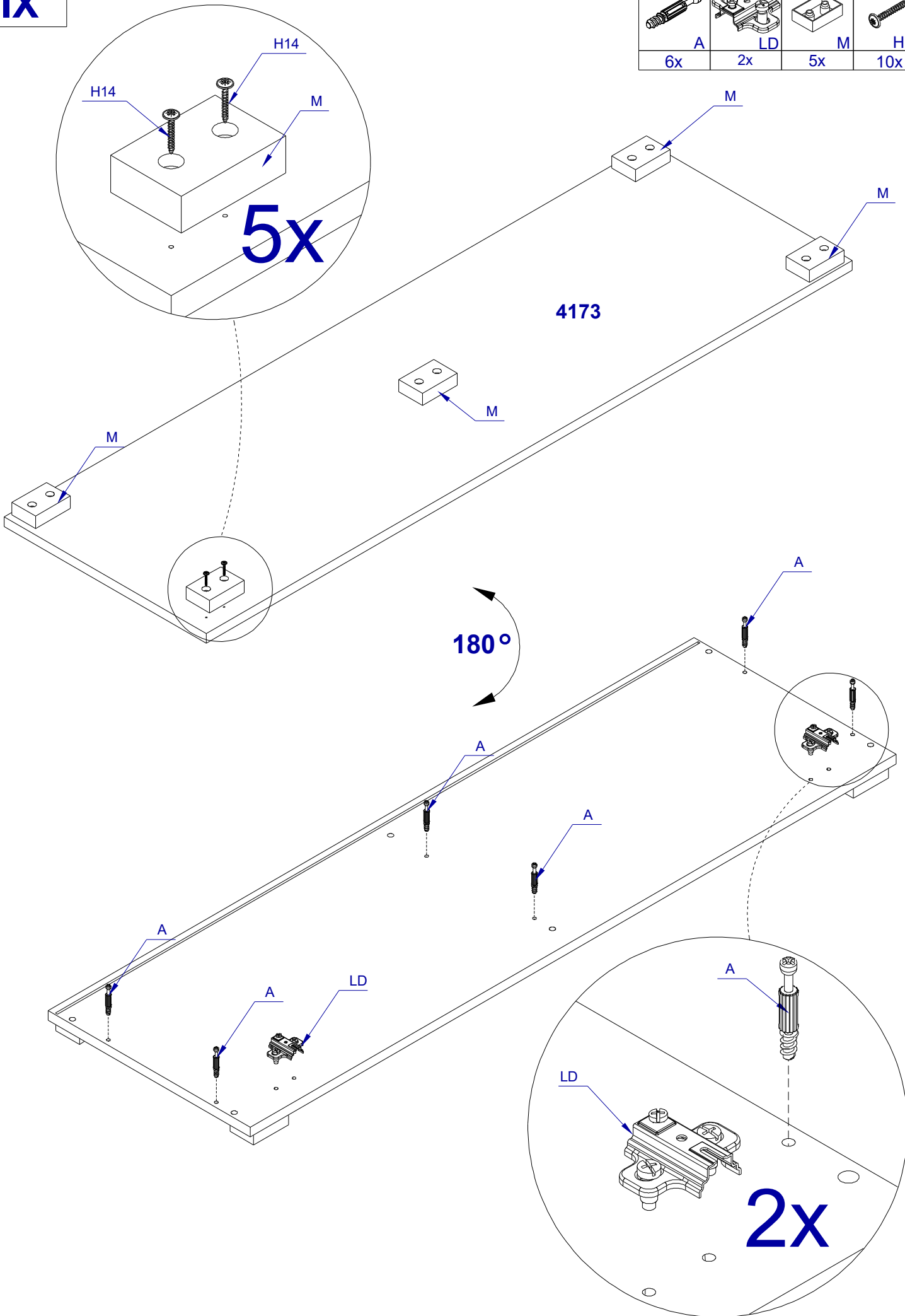
			
A	LD	M	H14
6x	2x	5x	10x

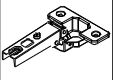

X

	4x16
	H8
ZD1	H8
2x	4x

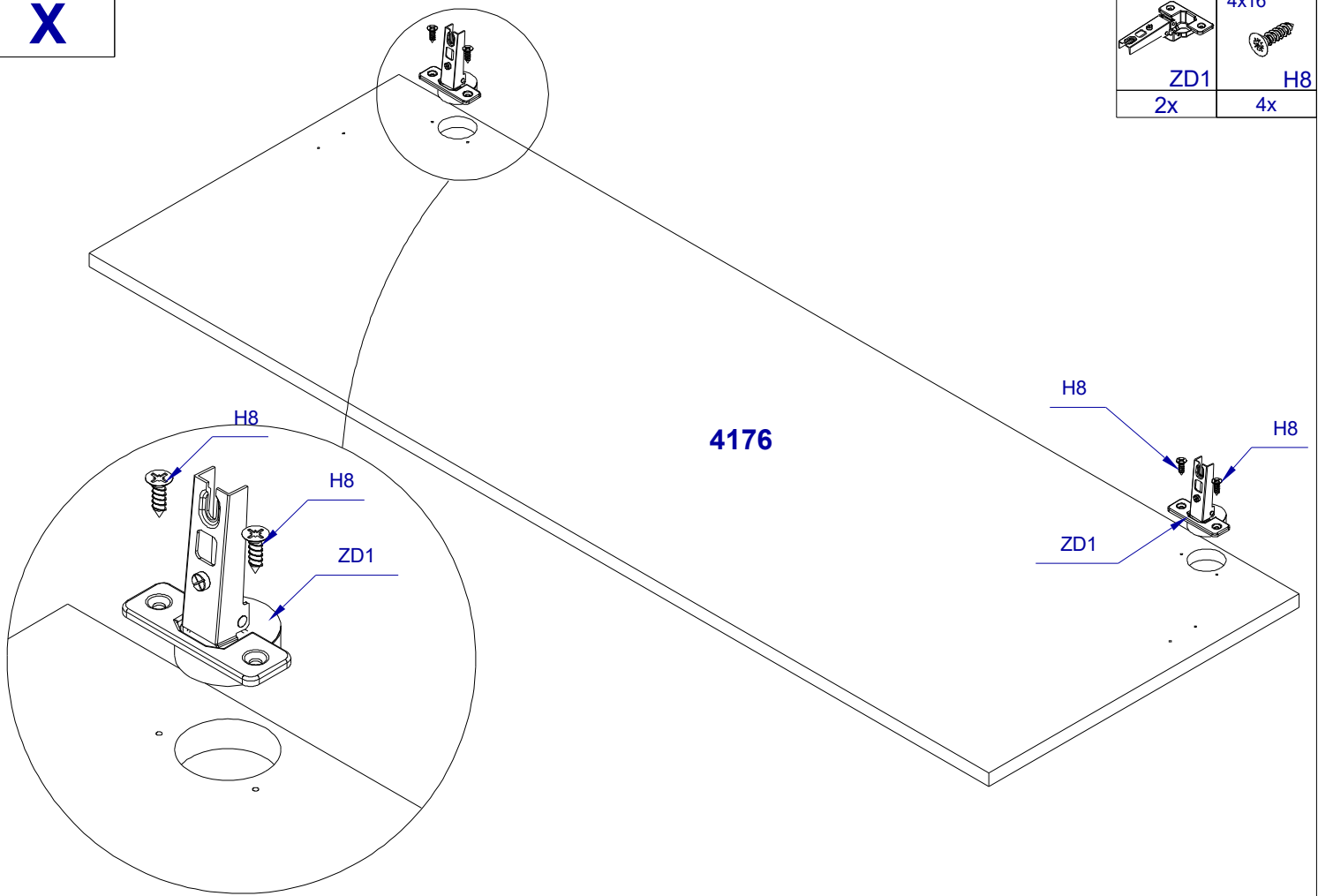

XI

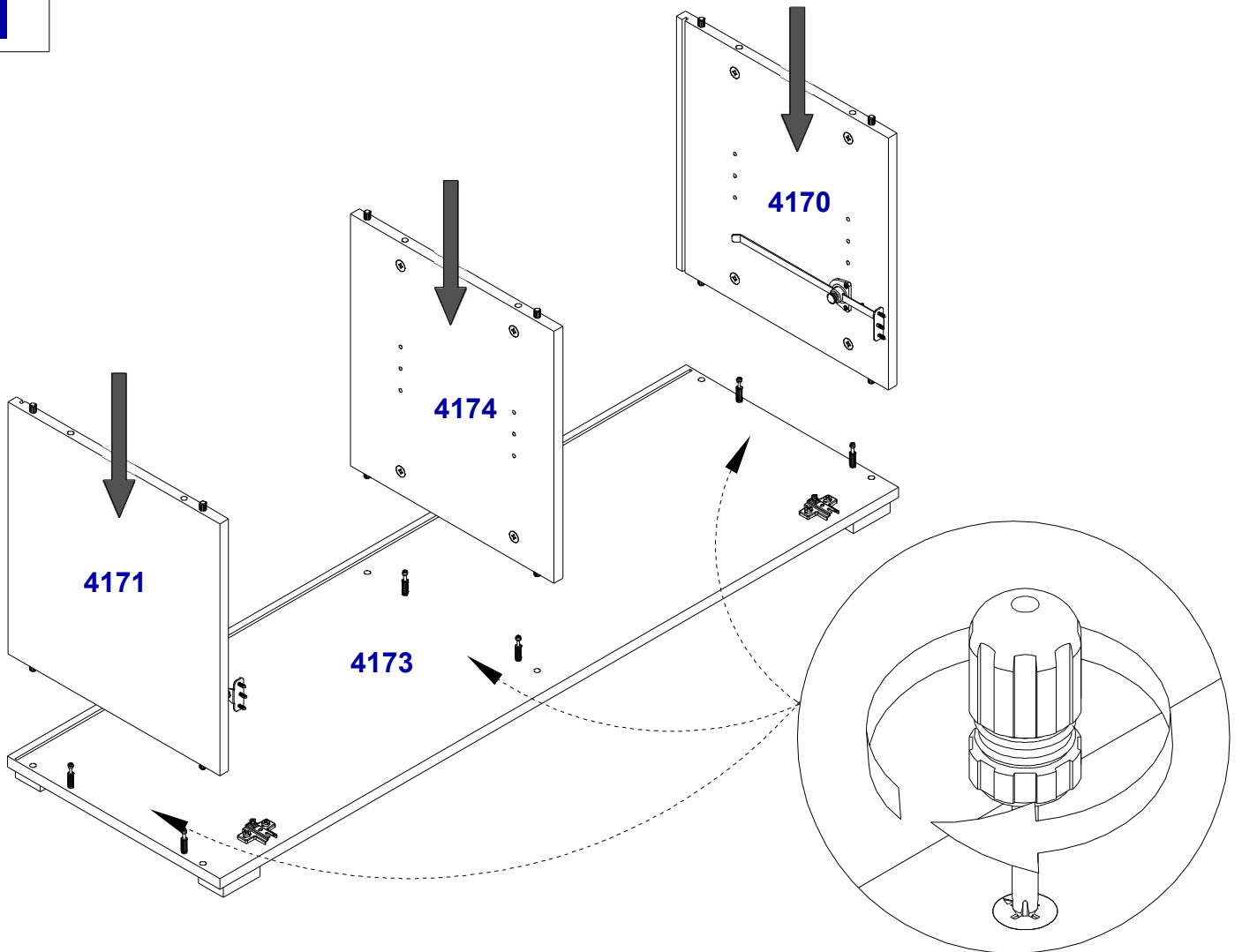

XII

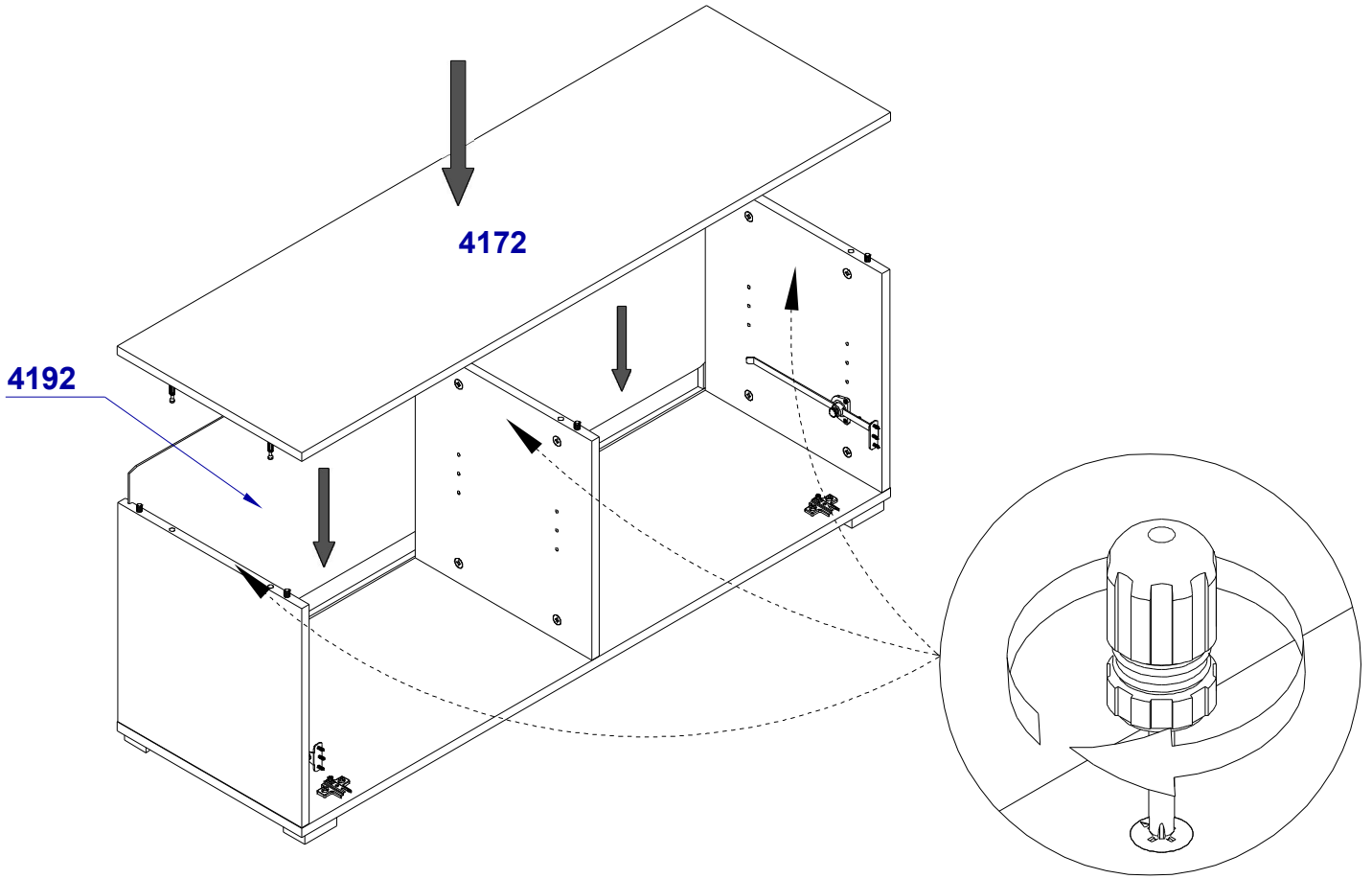

XIII

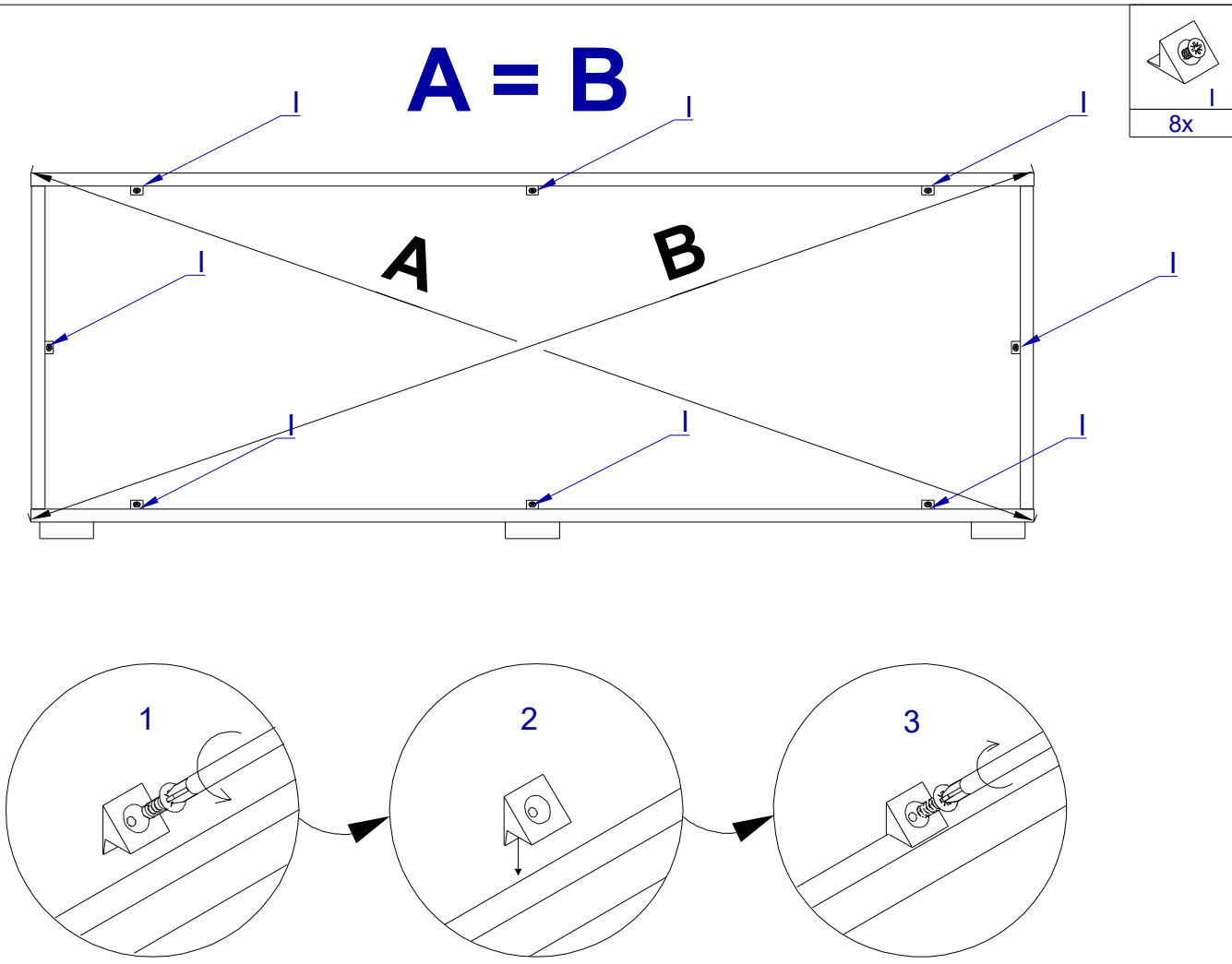

XIV

3x13



H

6x

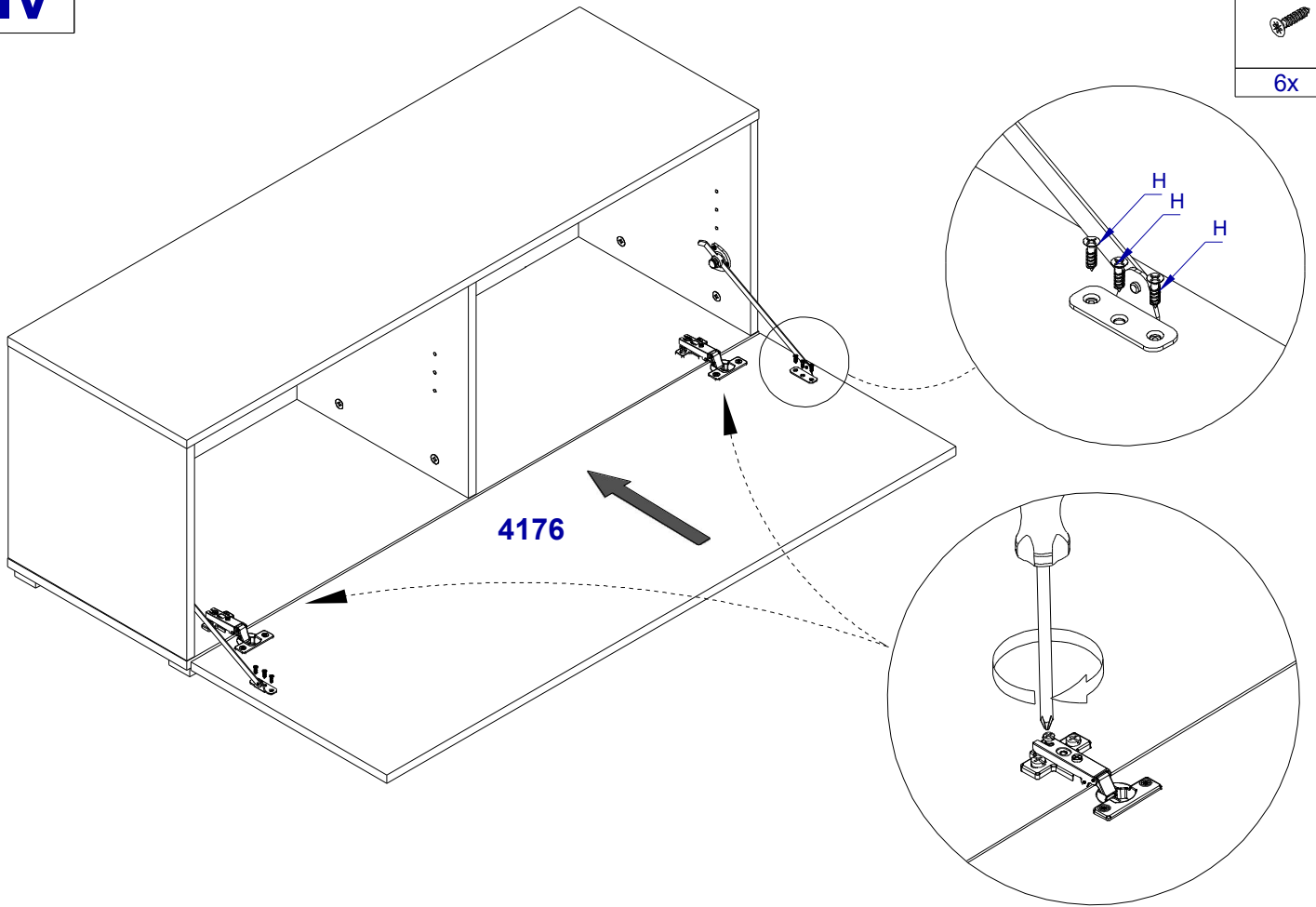

XV

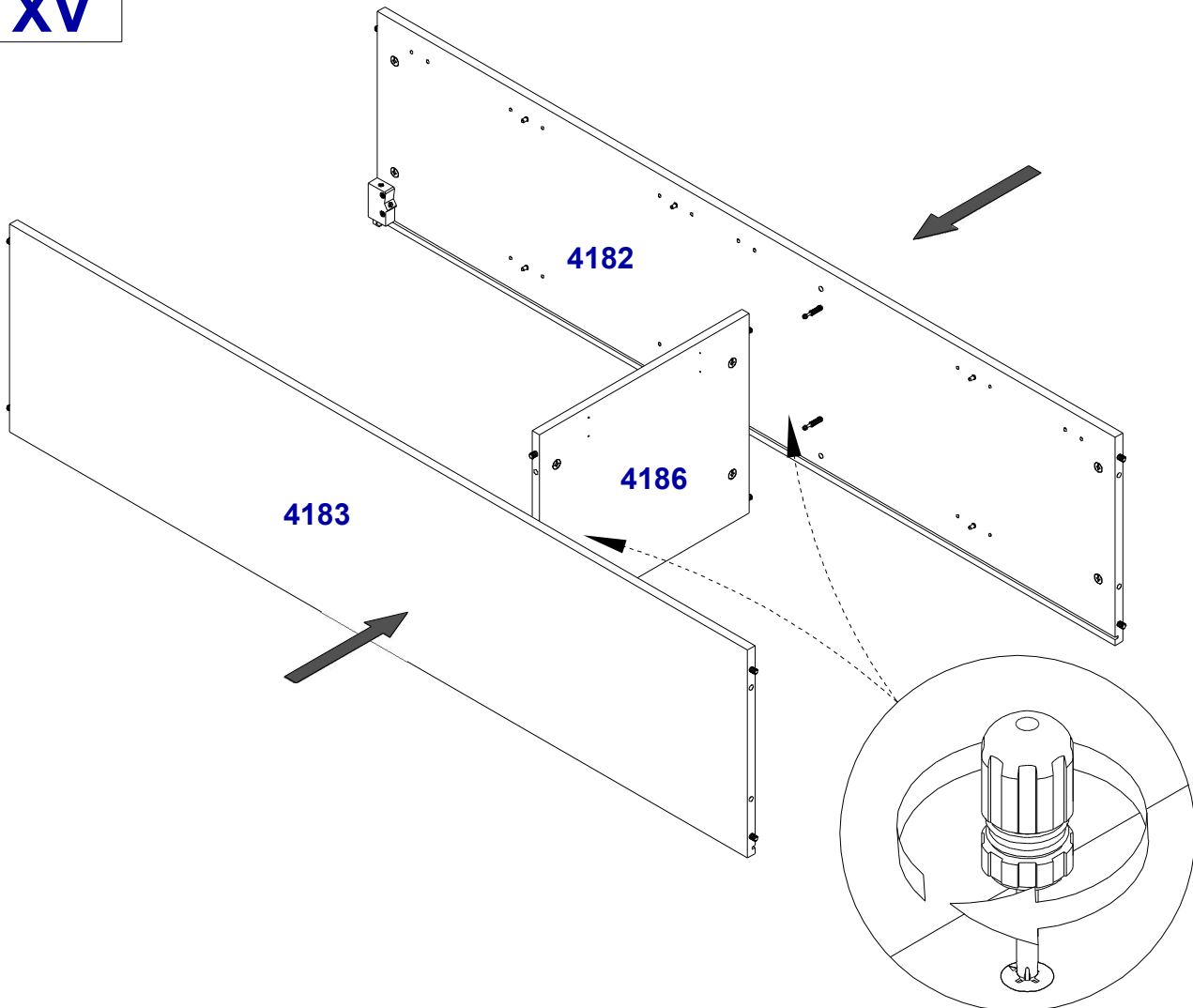

XVI

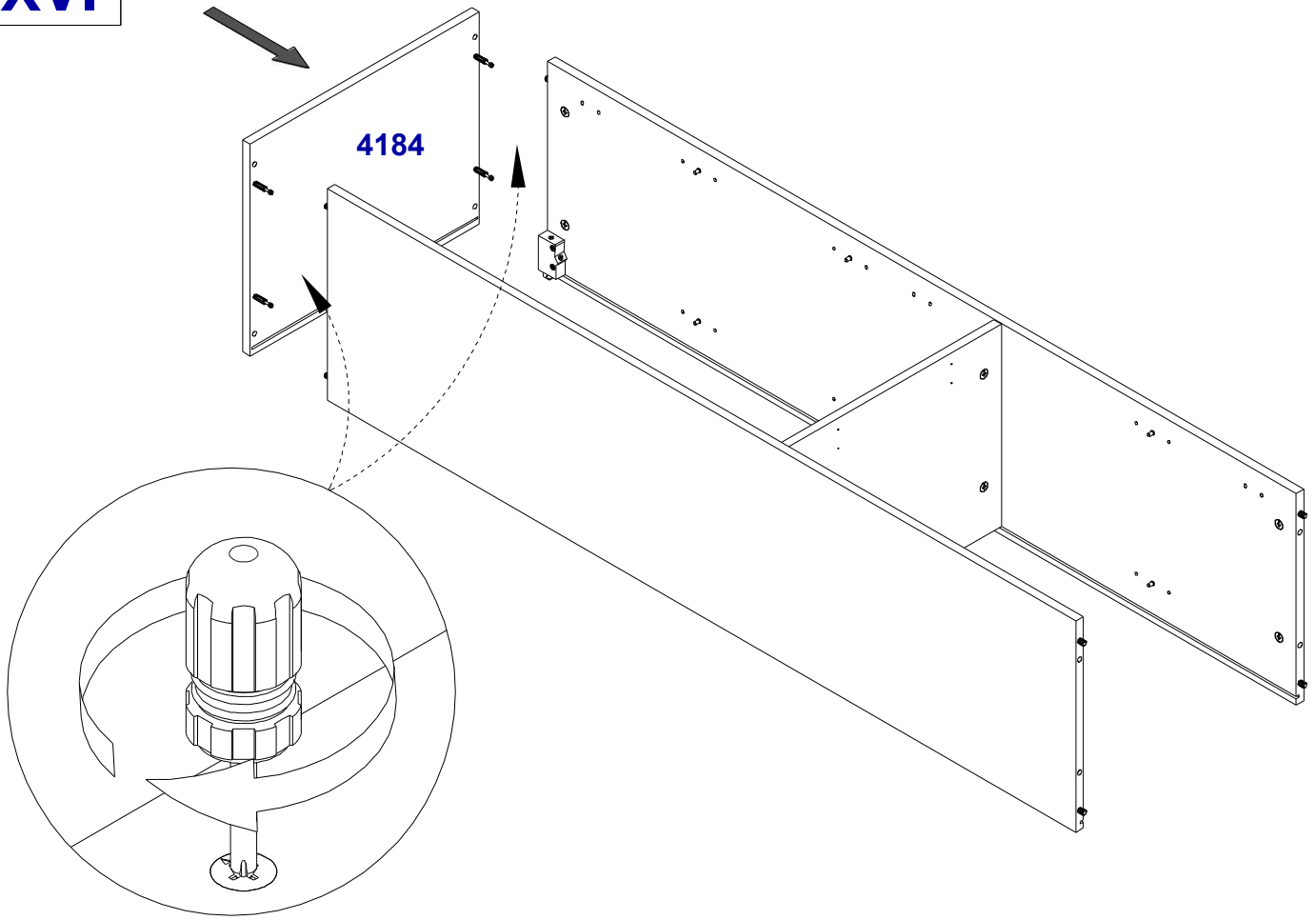

XVII

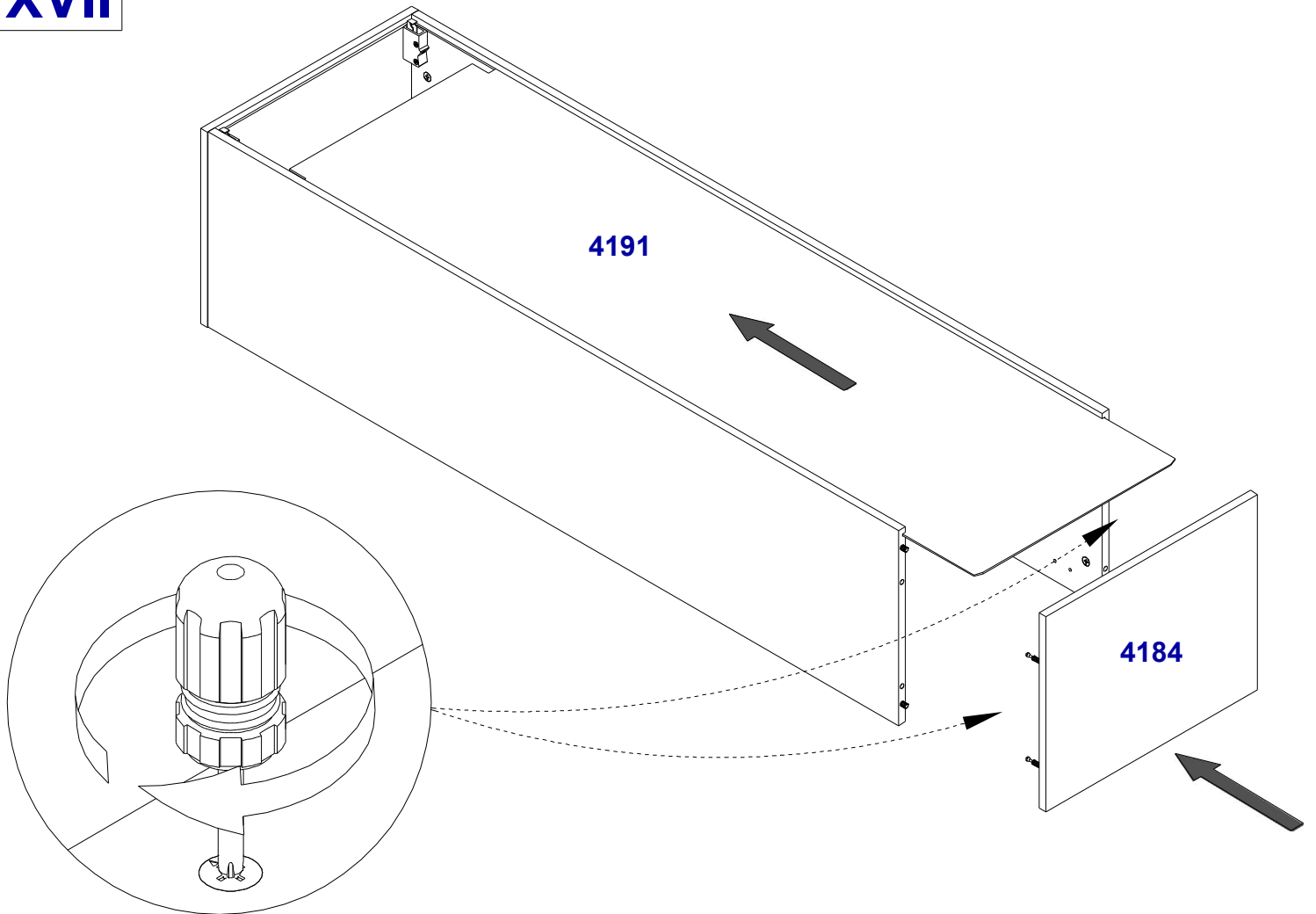

XVIII

A = B

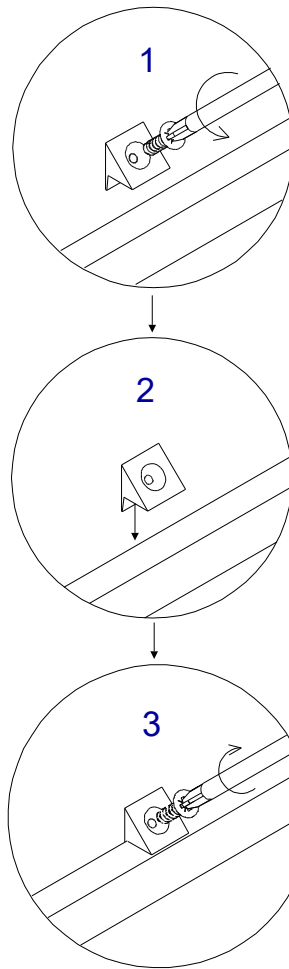
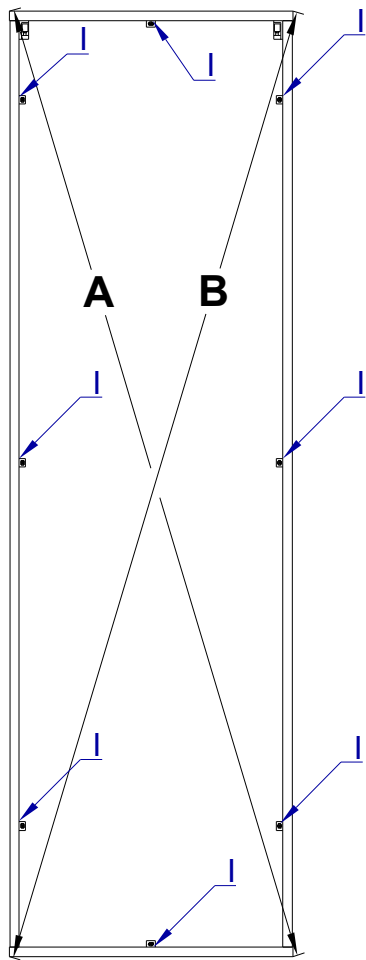

8x

XIX

4x22



H18

8x



ZT

4x

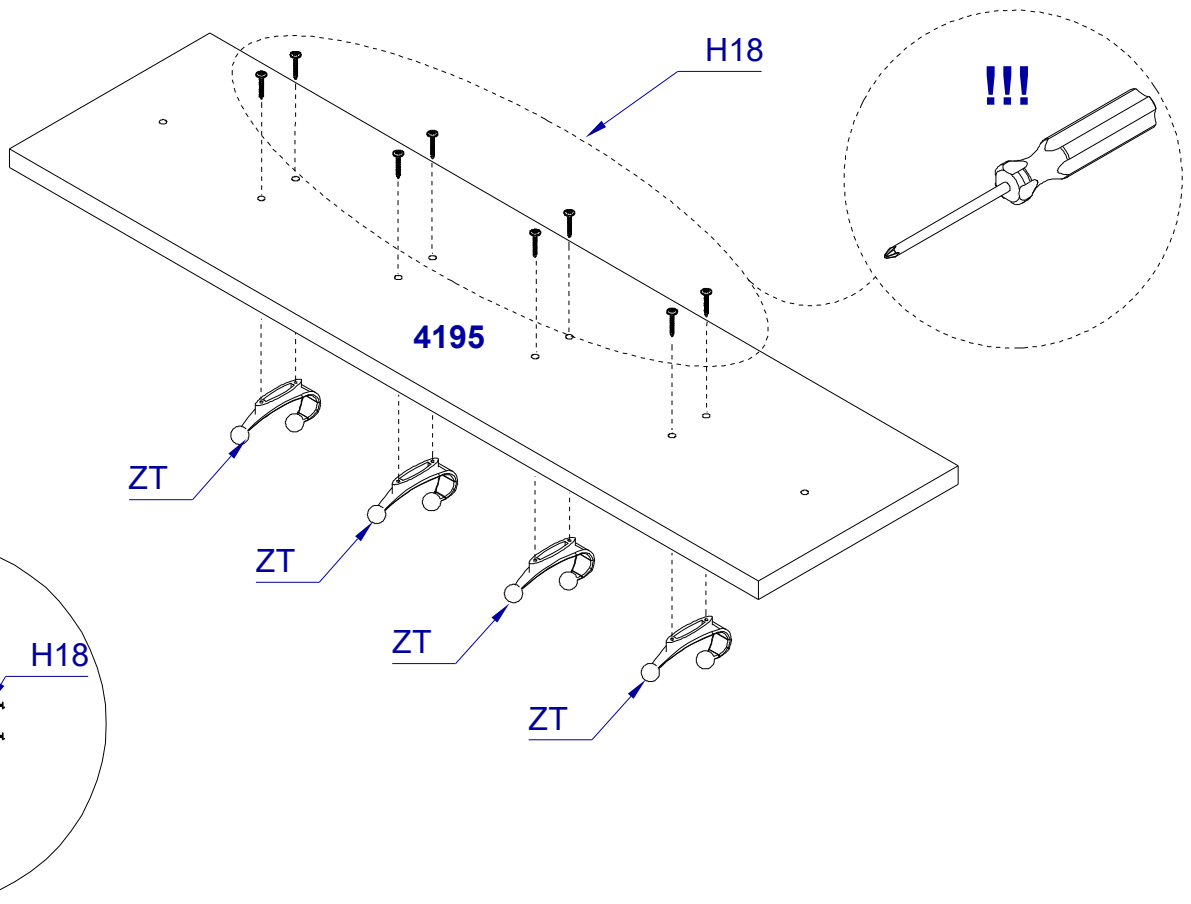

XX

7x

ET 4193

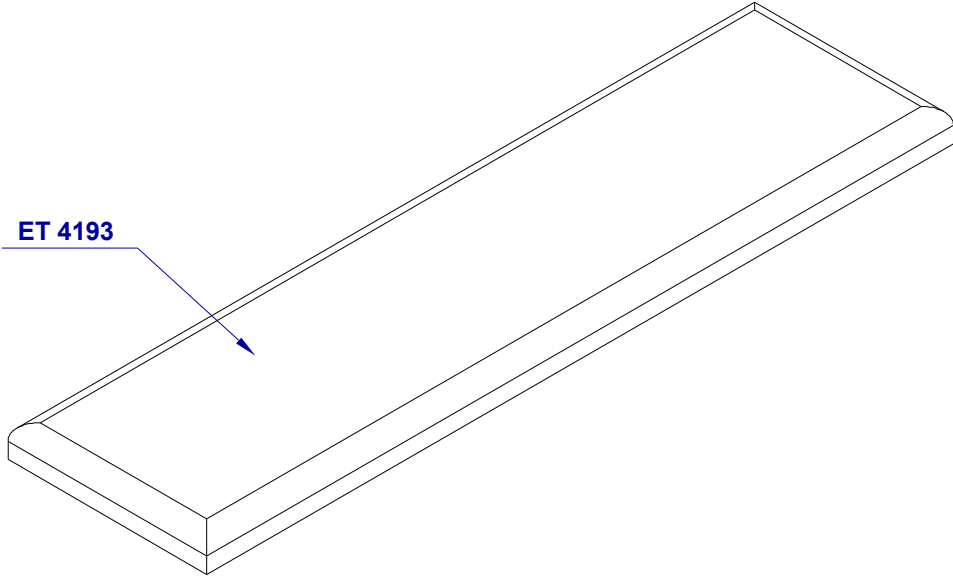

XXI

R

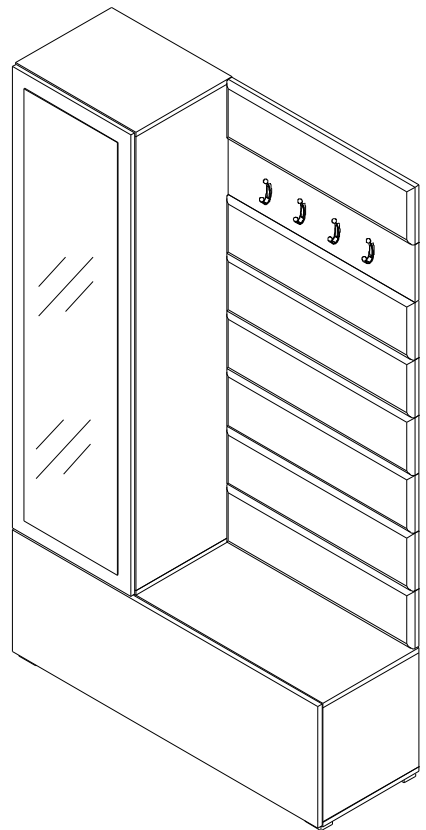
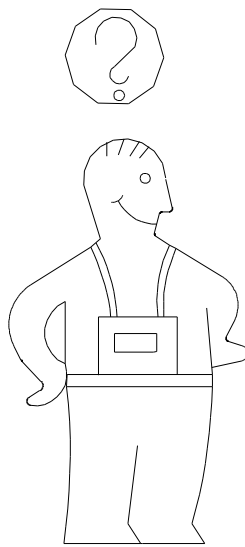
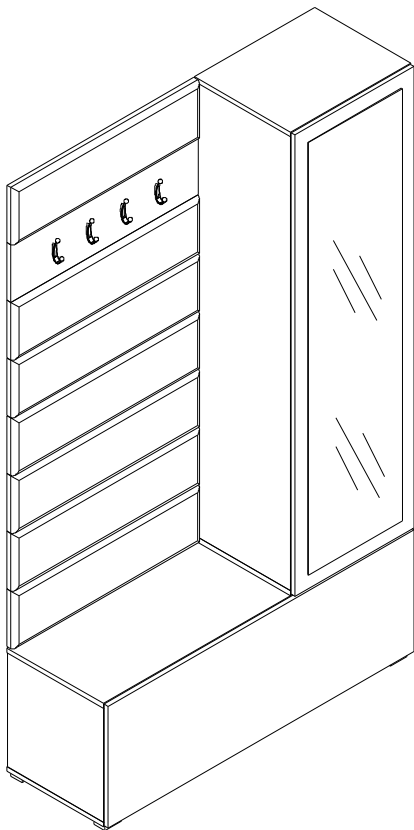

L



XXII



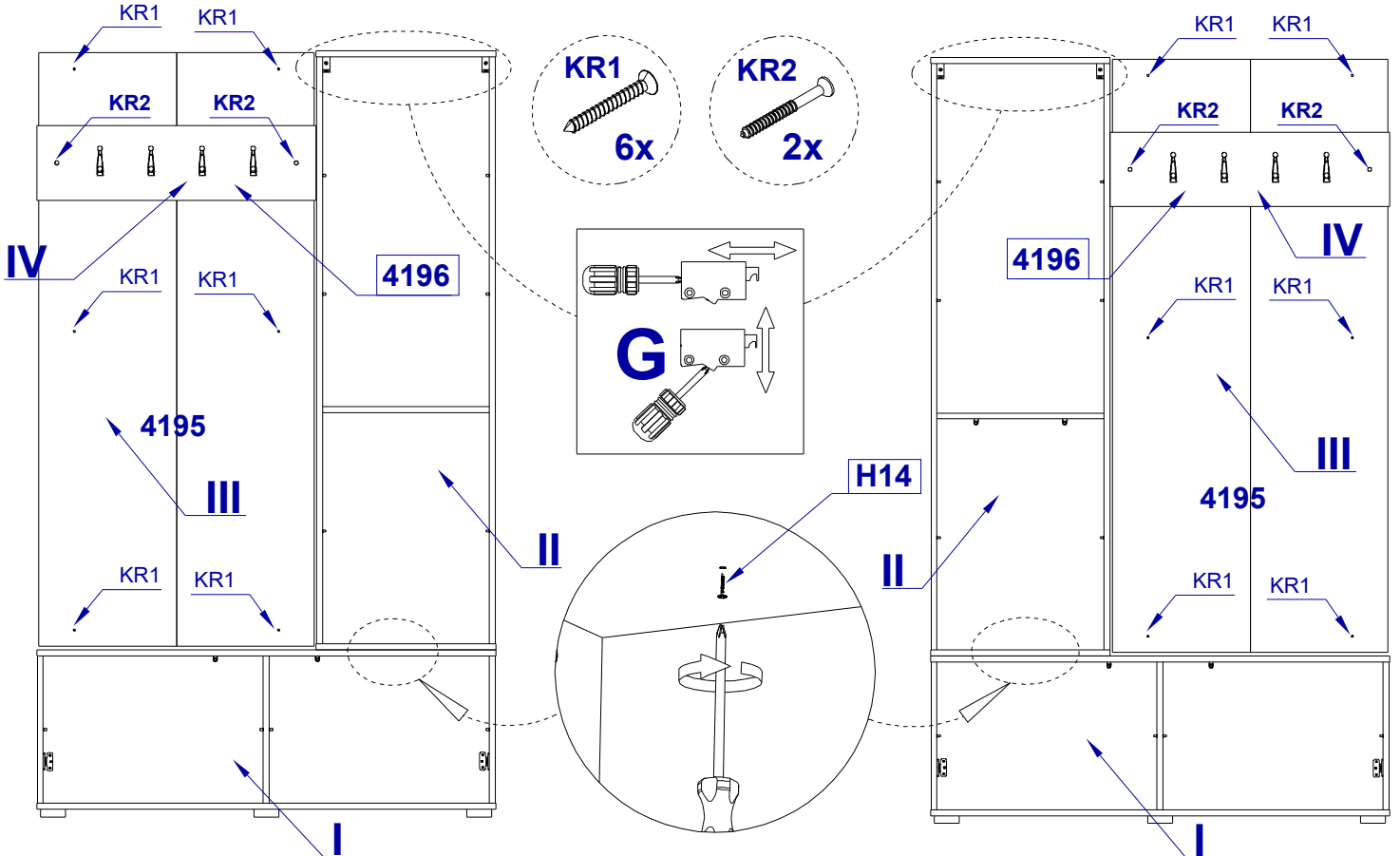
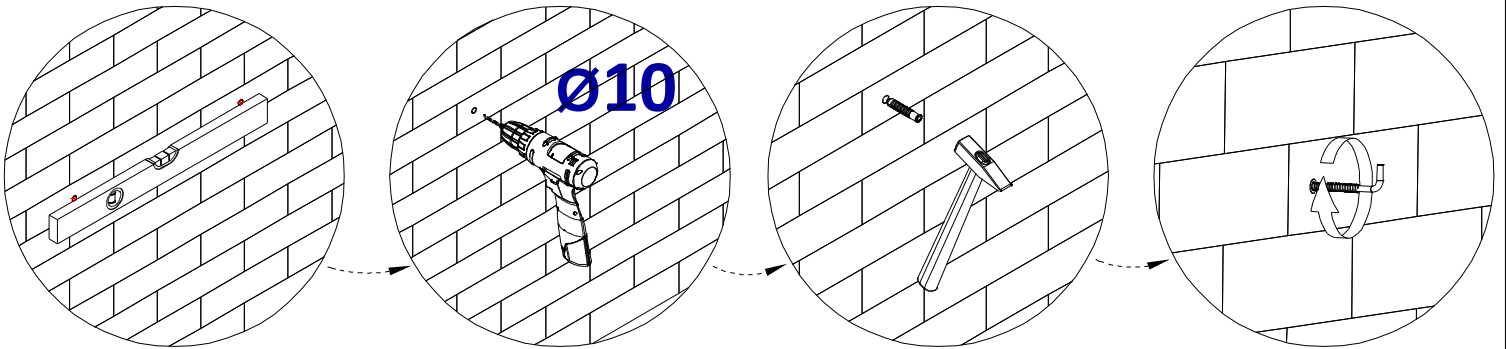
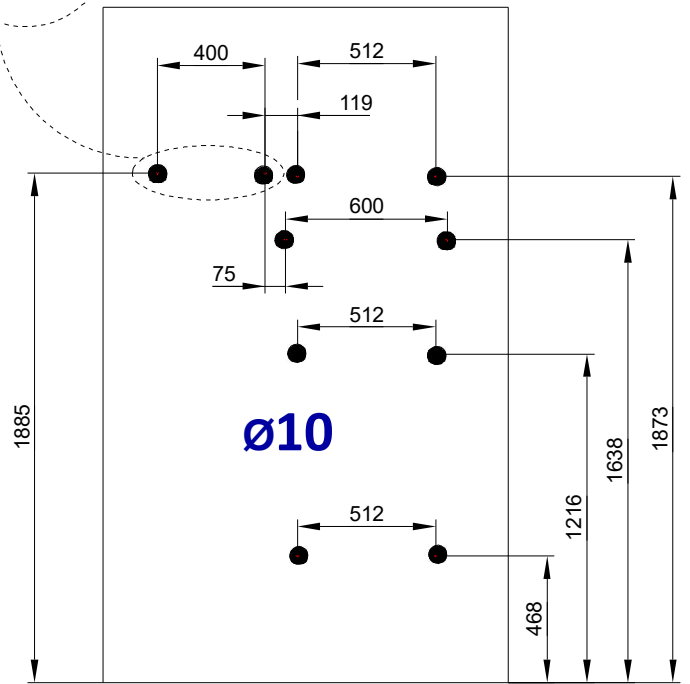
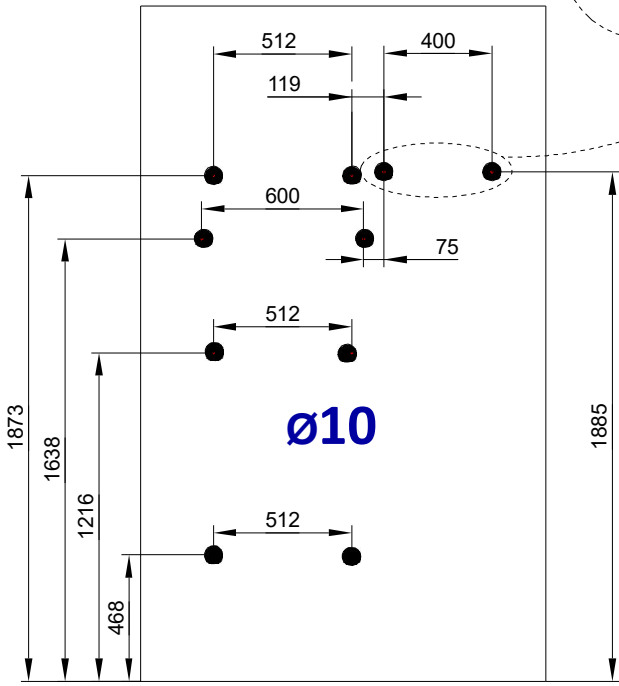
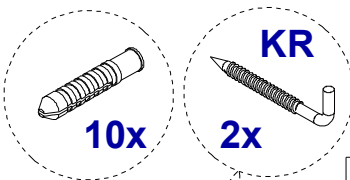

R

L

		
Ø10	Ø10	Ø10
KR	KR1	KR2
2x	x6	2x

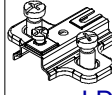

XXIII-R



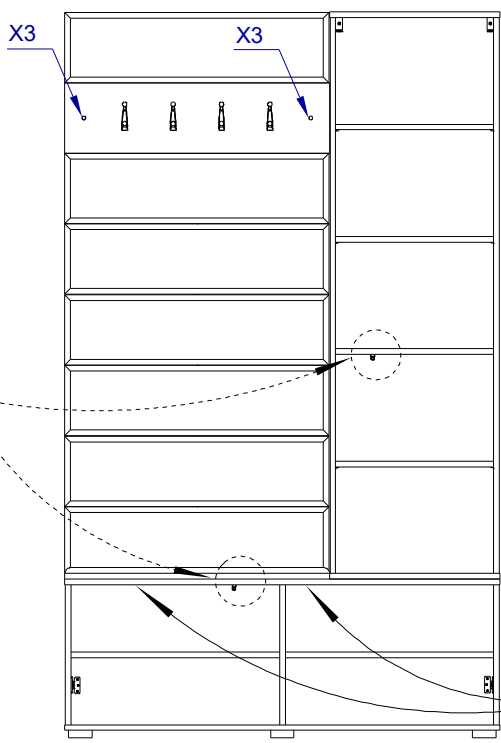
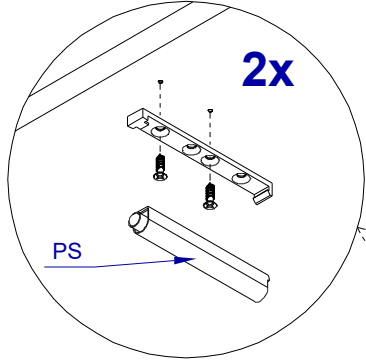
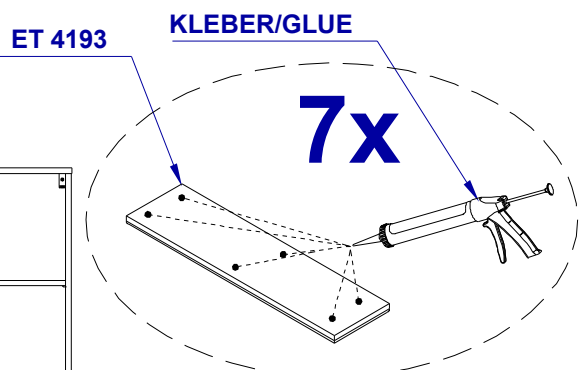
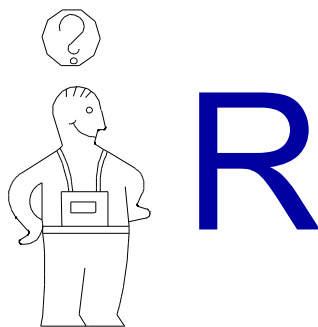
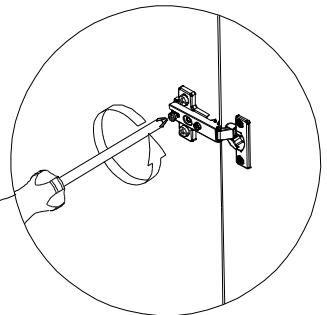
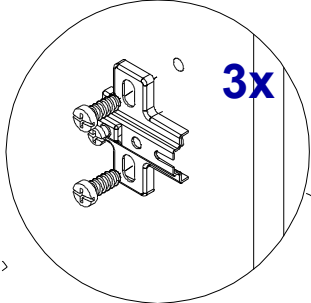
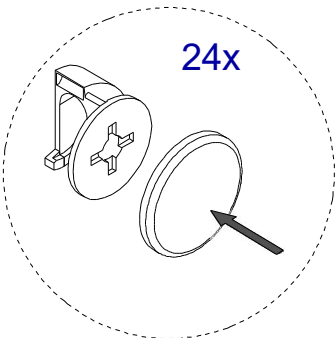
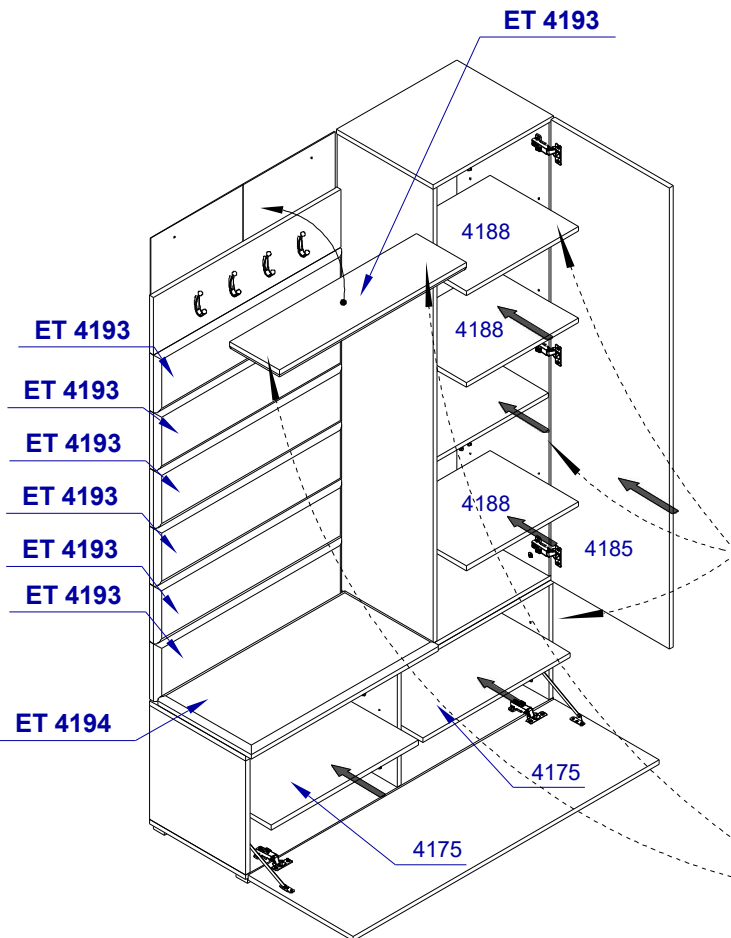

		
LD	PS	X3
3x	x2	26x
		4x22
		
		H14
		x2

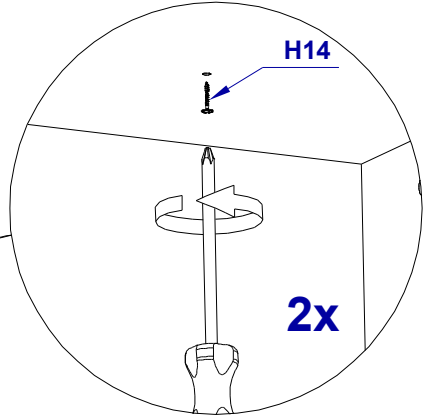
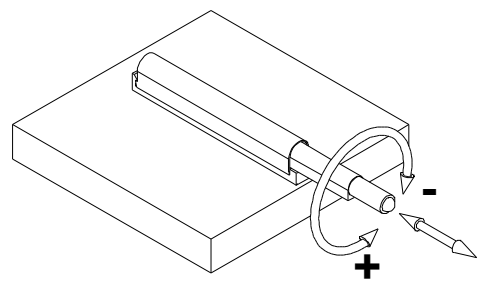

Klebe die die Paneele mit einen Montagekleber an der Wand fast. Verteile den Kleber gleichmäßig auf dem Paneele.
Hinweis: Der Kleber ist nicht im Lieferumfang enthalten.

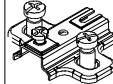

XXIII-L

		
LD	PS	X3
3x	2x	26x
		4x22
		
		H14
		x2

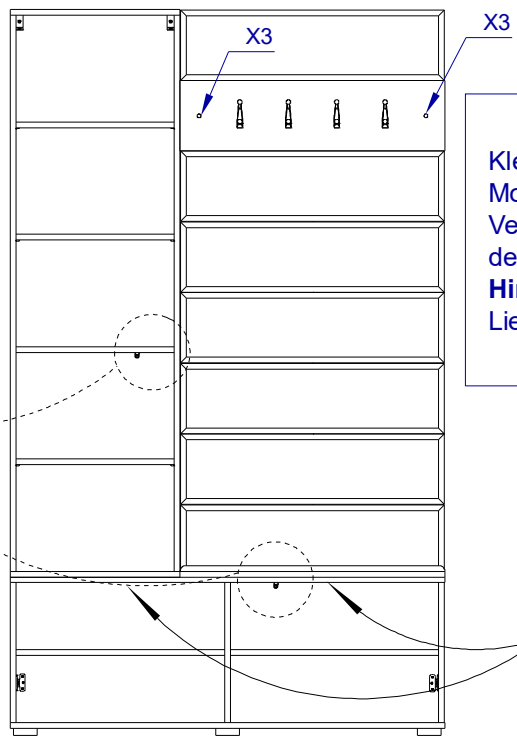
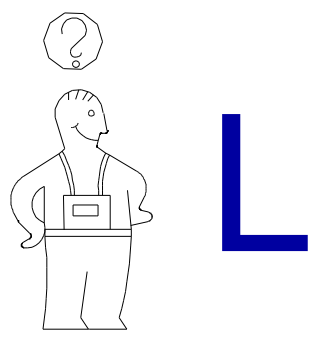
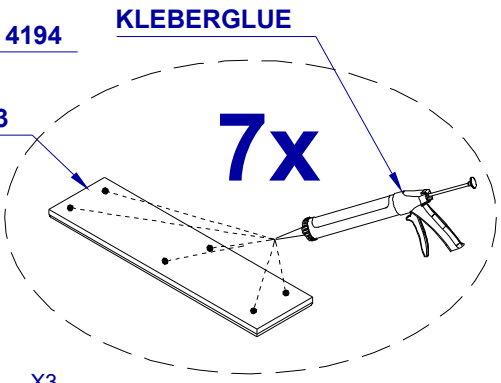
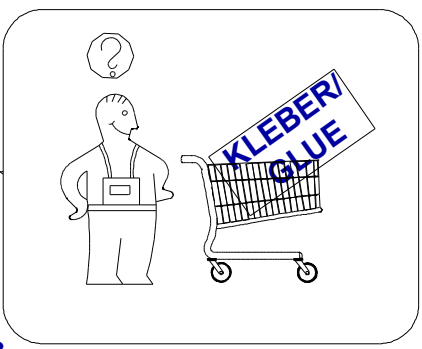
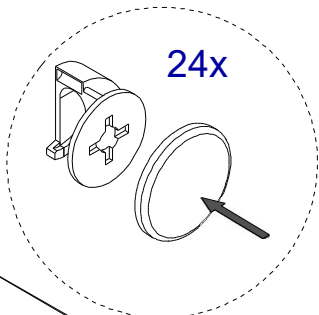
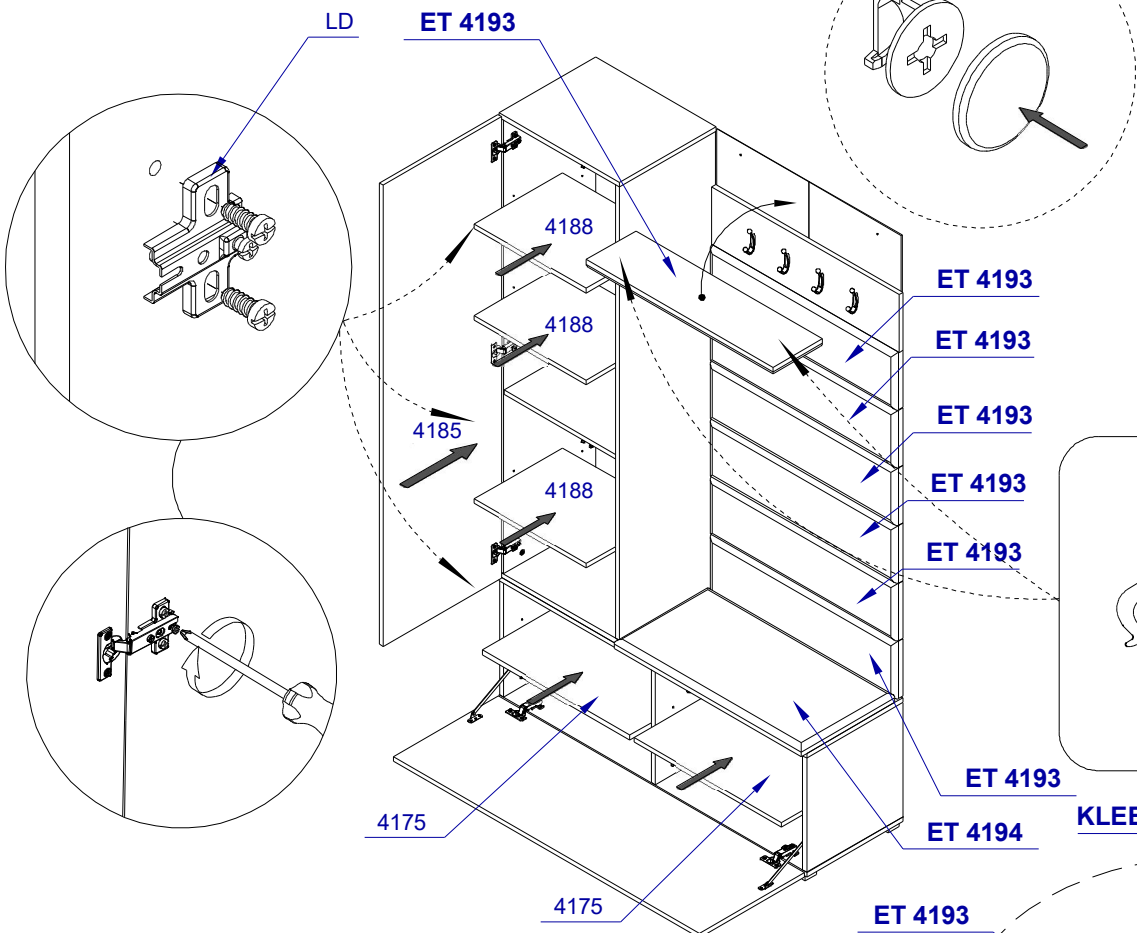

Klebe die die Paneele mit einen Montagekleber an der Wand fast. Verteile den Kleber gleichmäßig auf dem Paneele.
Hinweis: Der Kleber ist nicht im Lieferumfang enthalten.

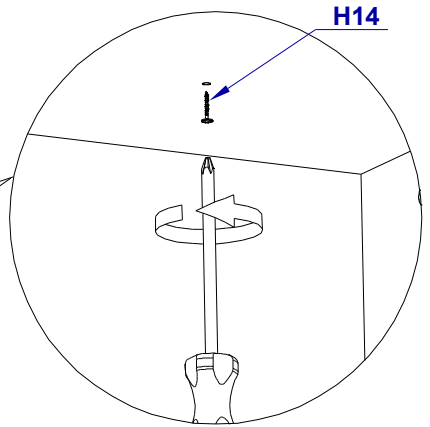
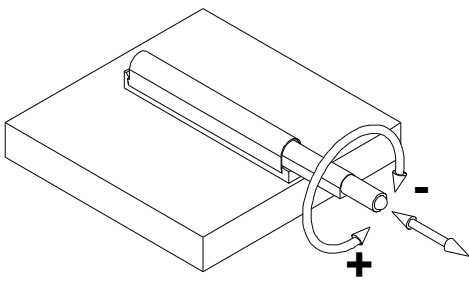
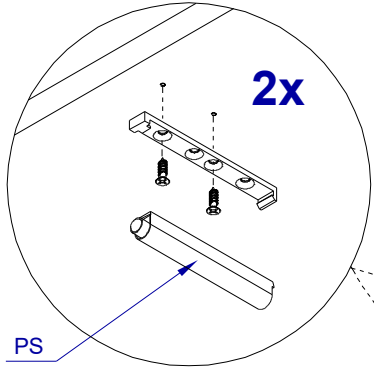

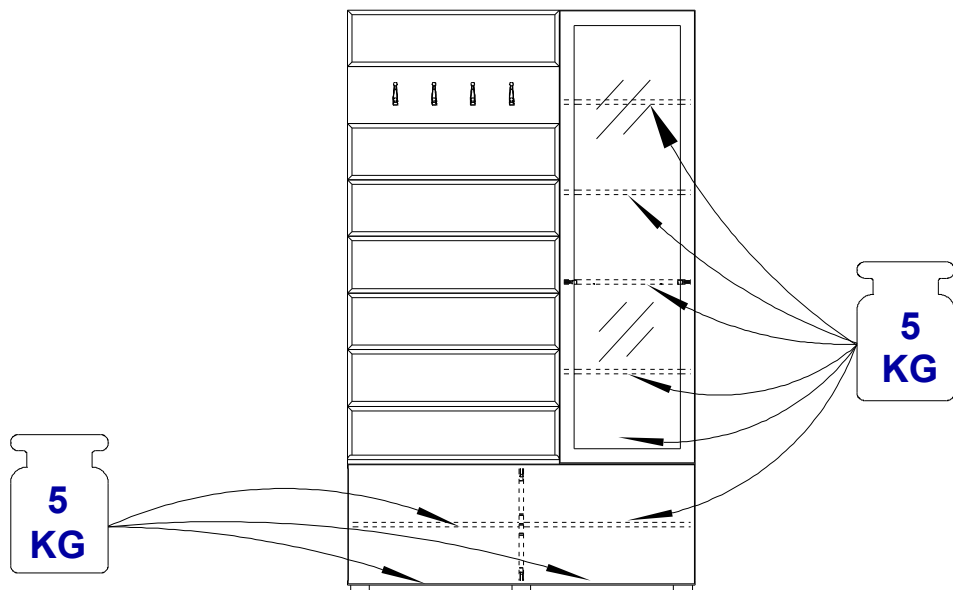
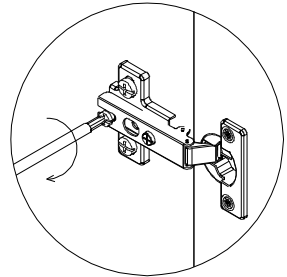
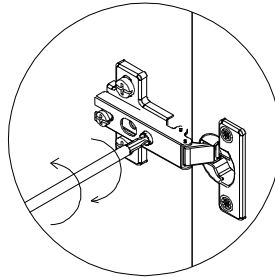
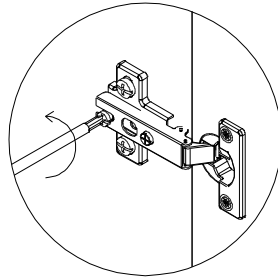
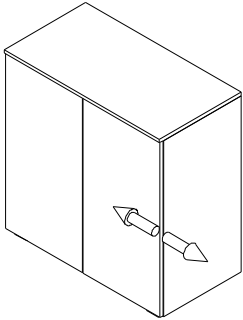
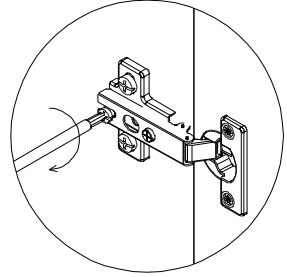
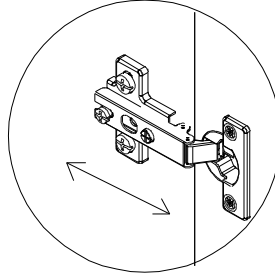
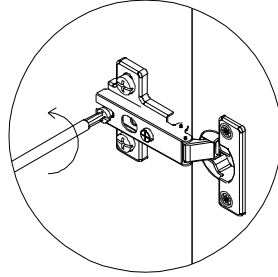
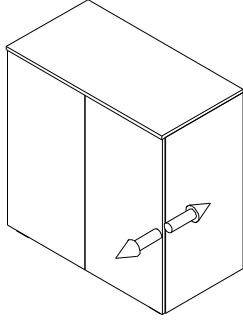
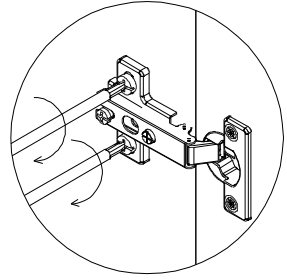
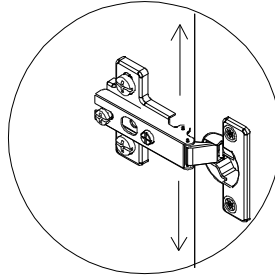
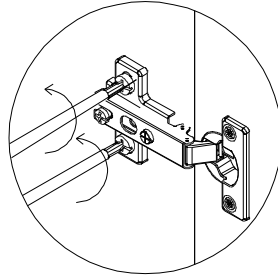
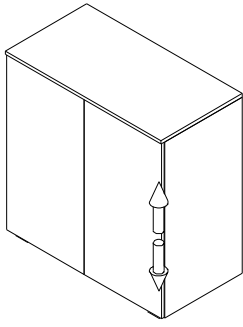

**Uwaga . Upozornini . Achtung . Attention . Caution . Figyelem
 Attenzione . Opgelet . Внимание . Atentie . Upozornenie . Dikkat
 . Uppmärksamhet . Pozor . Pa žnja**



PL	Załączony zestaw montażowy do zamocowania artykułu do ściany (kołki, wkręty, haki itp.), przeznaczony jest wyłącznie do montażu artykułu na ścianach wykonanych z cegły lub betonu. Przy montażu artykułu na ścianie wykonanej z innych materiałów, należy zastosować odpowiednie do niej zamocowania. W razie wątpliwości prosimy zasięgnąć porady fachowca. Uwaga: Mocowanie mebla do ściany mogą przeprowadzić wyłącznie wykwalifikowane osoby, z uwagi na zastosowanie odpowiednio dopasowanych kołków do rodzaju ściany.
CZ	Příložený materiál pro montáž na stěnu (hmoždinky a šrouby) je vhodný jen pro pevné zdivo (např. betonové nebo cihlové stěny). Pro jiné skladby stěn budou případně nutné speciální hmoždinky a jiné šrouby. Porad'te se případně s odborníkem. Pozor: Montáž nábytku na stěnu musí provést odborník, protože k montáži na stěnu jsou zapotřebi upravené hmoždinky.
D	Das beigefügte Wandbefestigungsmaterial (Dübel und Schrauben) eignet sich nur für festes Mauerwerk (zB. Beton- oder Ziegelwände). Für andere Wandaufbauten sind eventuell Spezialdübel und andere Schrauben notwendig. Ziehen Sie gegebenenfalls eine Fachkraft zurate. Achtung: Die Befestigung des Möbelstückes an der Wand muss von einer fachkundigen Person vorgenommen werdenda für die Montage an die Wand angepasste Dübel erforderlich sind.
GB	The enclosed wall mounting materials (dowels and screws) are only suitable for solid masonry (e.g. concrete or brick walls) . Special dowels and other screws may be necessary for other wall constructions. If necessary, please consult a qualified professional. Attention: A qualified professional is required when mounting furniture to the wall since dowels corresponding to the wall are required for this .
F	Le matériel de fixation murale fourni (chevilles et vis) convient uniquement a des murs solides (.ex. murs en béton ou en briques) Pour les autres constructions de murs, il faut éventuellement des chevilles spéciales et d'autres vis. Faites-vous conseiller par un spécialiste. Attention : La fixation du meuble contre le mur doit être effectuée par une personne compétente car, pour le montage mural, il faut utiliser des chevilles adaptées.
HU	A mellékelt fali rögzítőkészlet (tipli es csavarok) csak tömött falazatban (pi. betonfalbátéglafalban) hasznalható. Mas faltípusokhoz specialis tiplire es csavarra lesz szükseg. Szükseg eseten kerje ki egy szakember velemenyet Figyelem : A butorelemek falra rögziteset szakembernek kell vegeznie, mert a rögziteshez megfelelő tiplit kell használni
I	I materiali di fissaggio allegati (tasselli e viti) sono adatti solo ai muri compatti (ad .edi calcestruzzo o mattoni). Per altri tipi di pareti e probabile Che occorano tasselli speciali e altre tipologie di viti. Richiedere eventualmente il consiglio di un esperto. Attenzione: Il fissaggio del mobile alla parete deve essere eseguito da persone esperte, dato ehe occorrono tasselli adeguati
NL	Het bijgeleverde bevestigingsmateriaal (pluggen en schroeven) is geschikt voor vaste muren (betonnen of bakstenen muren). Voor andere muurconstructies zijn eventueel speciale pluggen en andere schroeven nodig. Raadpleeg indien nodig een specialist. Opgelet: een specialist dient het product aan de muur te bevestigen om te bepalen welk bevestigingsmateriaal gebruikt moet worden.
RU	Входящий в комплект поставки материал для крепления на стене (дюбели и болты) предназначен только для прочных каменных стен (например, бетонных или кирпичных). Для других типов стен используйте по мере необходимости специальные дюбели и другие болты. По мере необходимости обратитесь за помощью к специалистам. Внимание: Поскольку для монтажа на стене необходимо использовать специальные дюбели, мебель должна быть закреплена на стене квалифицированным персоналом.
RO	Înainte de suspendarea unei piese de mobilier sau ataşarea acestuia la perete (pentru a preveni bascularea), verificaţi în prealabil tipul şi gradul de rezistenţă a peretelui. Montaţi diblurile şi şuruburile adecvate pentru tipul de perete. În caz de îndoieli, consultaţi un specialist. Instalarea trebuie să fie efectuată de către o persoană competentă. ATENŢIE!!! Dacă un produs este livrat împreună cu dibluri cu şuruburi, înseamnă că este proiectat sunt proiectate exclusiv pentru pereţi realizaţi din materiale solide şi omogene.
SK	Příložený materiál pro upevnenie na stenu (hmoždinky a skrutky) je vhodný jen pre pevné murivo (např. betonové alebo tehlové steny). Pre iné steny su potrebné prip. nutné speciální hmoždinky a jiné šrouby. Porad'te se případně s odborníkem. Pozor: Montáž nábytku na stěnu musí provést odborník, protože k montáži na stěnu jsou zapotřebi upravené hmoždinky.
TR	Teslimat kapsamındaki duvar tipi sabitleme materyali (dıbel ve vidalar) sadece beton ve tuğla duvarları gibi sağlam duvar yapıları için uygundur. Başka duvar yapıları için özel dıbelller veya başka vidalar gerekli olabilir. Gerekirse bir uzmandan yardım alınız. Dikkat: Mobilya parçasının duvara sabitlenmesi, duvar montajı için özel uyarlanmış dıbelller gerektirdiğinden bu ş sadece bu konuda uzman bir kişi tarafından gerçekleştirilmelidir.
SE	Den medföljande monteringssetsen för att fästa artikeln på väggen (pluggar, skruvar, krokar, etc.) är endast avsedd för montering av artikeln på väggar av tegel eller betong. Vid montering av artikeln på en vägg gjord av andra material måste lämpliga fästelement användas. Om du är osäker, sök professionell rådgivning. Obs: Möbeln kan endast fästas på väggen av kvalificerade personer, på grund av användningen av stift som är lämpligt anpassade till väggtypen.
HR	Priloženi montažni set za pričvršćivanje artikla na zid (tiplje, vijci, kuke itd.) namijenjen je samo za montažu artikla na zidove od cigle ili betona. Prilikom montaže artikla na zid od drugih materijala moraju se koristiti odgovarajući pričvršćni elementi. Ako ste u nedoumici, molimo potražite stručni savjet. Napomena: Namještaj mogu pričvrstiti na zid samo kvalificirane osobe, zbog upotrebe klinova koji odgovaraju tipu zida.
SLO	Pred montažo pohištva na steno ali pritrditve le-tega k steni (v cilju preprečitve, da se ne prevrne) prej preverite vrsto in močnost stene. Izberite vložke in vijake, ki odgovarjajo stene. V primeru dvomov se posvetujte s specialistom. Montažo sme opraviti izključno ustrezno kvalificirana oseba. POZOR!!! Če so kizdelku priloženi razporni vložki z vijaki, so le-ti namenjeni samo in izključno za montažo na stene, izdelane iz masivnih in homogenih materialov.

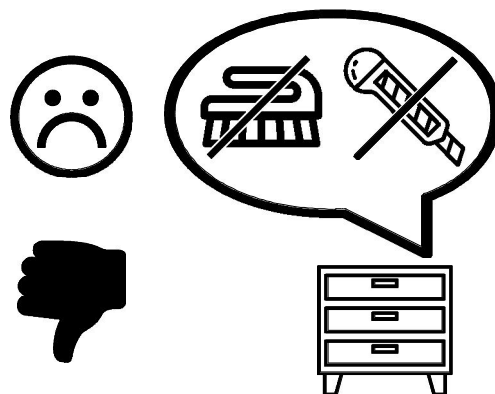
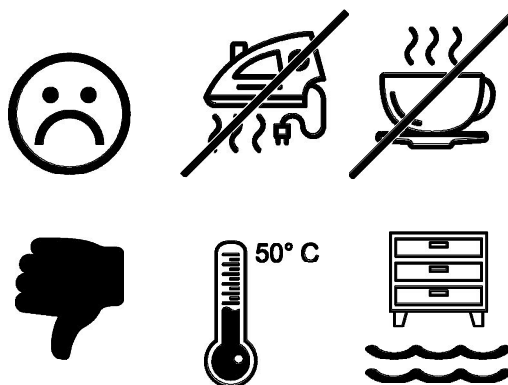
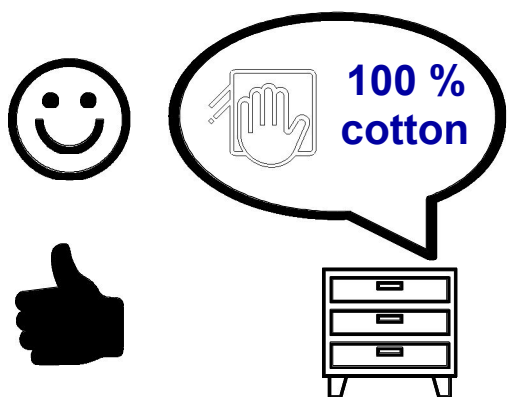

FR
**Donnez ou recyclez
vos meubles.**



ou



ou



Déchèterie

<https://quefairedemesdechets.fr>



**CARTON
+ PLASTIQUE
+ NOTICE**



*Séparez les éléments
avant de trier*