

TETRIS

LKZ 42416 / 75033

04

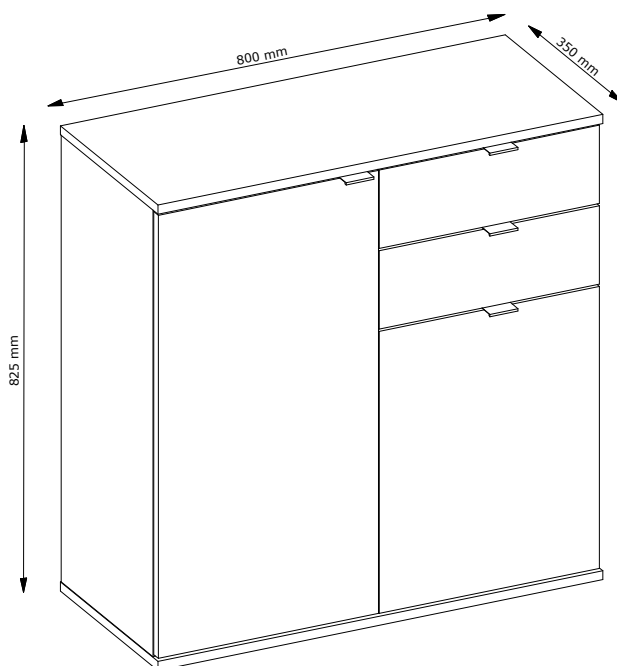

D **Montageanleitung**
Kommode >Tetris<

FR **Notice de montage**
La commode >Tetris<

NL **Handleiding voor de montage**
Dressoir >Tetris<

CZ **Montážní návod**
Prádelník >Tetris<

HU **Szerelési útmutató**
Öltözködőasztal >Tetris<

TR **Montaj talinatl**
Şifonyer >Tetris<

ES **Instrucciones de montaje**
Aparador >Tetris<

GB **Assembly instructions**
Dresser >Tetris<

IT **Intruzioni di montaggio**
Costumista >Tetris<

PL **Instrukcja montażu**
Komoda >Tetris<

SK **Návod na montáž**
Dresser >Tetris<

RO **Instructiuni de montaj**
Dulap >Tetris<

RU **Инструкция по монтажу**
Комод >Tetris<

PT **Instruções de montagem**
Cómoda >Tetris<

SRB **Упутства за инсталацију**
ГРУДИ фиоке >Tetris<

HR **Upute za instalaciju**
Komoda >Tetris<

SL **Návod na montaž**
Komoda >Tetris<

LT **Surinkimo instrukcijos**
Komoda >Tetris<

LV **Montāžas instrukcija**
Komoda >Toll<

EE **Kokkupaneku juhised**
Komoda >Tetris<

BG **Инструкции за сглобяване**
Скрин >Tetris<

BA **Upute za sastavljanje**
Komoda >Tetris<

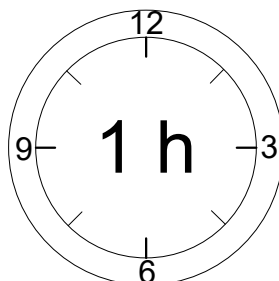
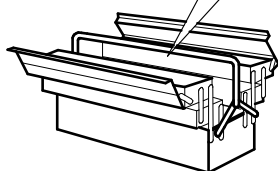
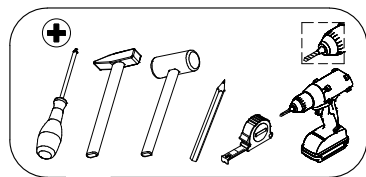
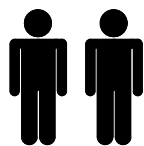

Adresses sur quefaire.demesdechets.fr



* 2 8 4 9 6 0 *

D-Ziehen Sie alle Schrauben sowie tragende Verbindungsteile nach ca. 5 Wochen nach, um einedauerhafte Standsicherheit zu gewährleisten.

GB-After approx. 5 weeks, tighten all screws and load-bearing connecting parts to ensure permanent stability.

FR-Resserrez toutes les vis ainsi que les pièces de fixation au bout d'environ 5 semaines pour garantir une sécurité de fixation durable.

IT- Ristringere tutte le viti e giunture dopo ca. 5 settimane, al fine di garantire una durevole solidità.

NL-Draai alle schroeven en ook dragende verbindingstukken na ca. 5 weken nog eens vast, zodateen continue stabiliteit wordt gegarandeerd.

PL-Prosimy po ok. 5 tygodniach dokręcić wszystkie śruby i elementy łączeniowe. Zagwarantuje to Państwu trwałość i stabilność połączeń.

CZ- Dotáhněte všechny šrouby a nosné spojovací díly přibližně po 5 týdnech, aby se zaručila trvalá stabilita.

SK-Po cca 5 týždňoch dotiahnite skrutky, aby bola zaručená ich trvalá stabilita.

HU-Húzza utána - kb. 5 hét múlva - az összes csavart és a teherhordó összekötő-alkatrészeket abiztonság érdekében.

RO-Pentru a asigura o stabilitate de durată, strângeți după cca. 5 săptămâni toate șuruburile, precumși toate elementele portante de legătură.

TR-Tüm vida ve taşiyıcı bağlanti parçalarını kalıcı bir duruş güvenliğini sağlamak için yaklaşık 5 haftasonra tekrar sıkınız.

RU - Подкрутите все болты, а также несущие соединительные детали приibl. через 5 недель для обеспечения устойчивости в течение длительного времени.

SRB - Molim vas posle akrokca. 5 nedelja zategnite sve šrafove i pričvršćivače. To će vam garantovati trajnost i stabilnost veza.

HR - Molim vas, nakon cca. 5 tjedana zategnite sve vijke i pričvršćivače. To će vam jamčiti trajnost i stabilnost priključaka.

SL - Pýtame sa po cca. 5 týždňov utiahnite všetky skrutky a upevňovacie prvky. To zaručuje trvanlivosť a stabilitu spojov.

LT - Mes prašome po maždaug. 5 savaites priveržkite visus varžtus ir tvirtinimo detales. Taip užtikrinamas jungčių patvarumas ir stabilumas.

LV - Mēs lūdzam pēc apm. 5 nedēļas, pievelciet visas skrūves un stiprinājumus. Tas garantē savienojumu izturību un stabilitāti.

EE - Kúsime pärast ca. 5 nädalat, pingutage kõiki kruvisid ja kinnitusi. See tagab ühenduste vastupidavuse ja stabiilsuse.

ES Apriete todos los tornillos y elementos de conexión después de aprox. 5 semanas. Esto le garantizará la durabilidad y estabilidad de sus conexiones.

PT Aperte todos os parafusos e elementos de ligação após aprox. 5 semanas. Isto garantirá a durabilidade e estabilidade das suas ligações.

BA Zategnite sve zavrtnje i spojne elemente nakon cca. 5 sedmica. To će vam garantirati trajnost i stabilnost vaših veza.

BG Моля, затегнете всички винтове и свързващи елементи след приibl. 5 седмици. Това ще ви гарантира дълготрайност и стабилност на вашите връзки.

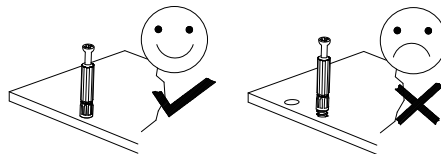

D Bitte nur mit einem Staubtuch oder leicht feuchtem Lappen reinigen. Keine scheuernden Putzmittel verwenden.

GB Please only clean with a duster or a damp cloth. Do not use any abrasive cleaners.

FR Veuillez nettoyer uniquement avec un chiffon à poussière ou un chiffon légèrement humide. Ne pas utiliser de détergent abrasif.

IT Si raccomanda di pulire solo con un panno per la polvere o uno strofinaccio umido. Non utilizzare detersivi abrasivi.

NL Reinig alleen met een stofdoek of een lichtjes vochtige doek. Gebruik geen schurende poetsmid-delen.

PL Czyszczenie należy wykonać wyłącznie za pomocą ściereczki lub lekko nawilżonego ręcznika. Nie stosować środków czyszczących do szorowania.

CZ Čistěte prosím jen prachovkou nebo lehce navlhčeným hadrem. Nepoužívejte drhnutí čistící prostředky.

SK Na čistenie používajte len prachovku alebo zľahka navlhčenú utierku. Nepoužívajte žiadne drhúce čistiace prostriedky.

HU Kérjük, csak portórló kendővel vagy enyhén nedves ronggyal tisztítsa. Ne használjon dörzshatású tisztítószeret.

RO Vă rugăm să utilizați la curățare exclusiv o cârpă de șters praful sau o cârpă ușor umezită. Nu utilizați substanțe de curățat abrazive.

TR Lütfen sadece bir toz beziiyle veya hafif nemli yumuşak bir bezle siliniz. Aşındırıcı temizlik malze-meleri kullanmayınız.

RU Для чистки используйте, пожалуйста, тряпку для пыли или слегка влажную ветошь. Не использовать абразивные чистящие средства.

SBR Чишћење треба обавити само крпом или благо влажним пешкиром. Немојте користити средство за чишћење рибања.

HR Čišćenje treba obaviti samo krpom ili blago navlaženim ručnikom. Ne koristite sredstva za čišćenje ribanja.

SL Čistenie by sa malo vykonávať len handričkou alebo ľahko navlhčeným uterákom. Nepoužívajte čistiace prostriedky na drhnutie.

LT Valyti galima tik šluoste arba lengvai sudrėkintu rankšluosčiu. Nenaudokite šveičiamųjų valiklių.

LV Tīrīšana jāveic tikai ar drānu vai viegli samitrinātu dvieli. Neizmantojiet tīrīšanas līdzekļus.

EE Puhastada tohib ainult lapiga või kergelt niisutatud rätikuga. Ärge kasutage puhastusvahendeid.

ES La limpieza debe realizarse únicamente con un paño o toalla ligeramente húmedo. No utilice agentes de limpieza abrasivos.

PT A limpeza deve ser feita apenas com um pano ou toalha ligeiramente húmida. Não utilize produtos de limpeza abrasivos.

BG Почистването трябва да става само с парцал или леко навлажнена кърпа. Не използвайте абразивни почистващи препарати.

BA Čišćenje treba obavljati samo krpom ili blago vlažnim peškirom. Nemojte koristiti abrazivna sredstva za čišćenje.

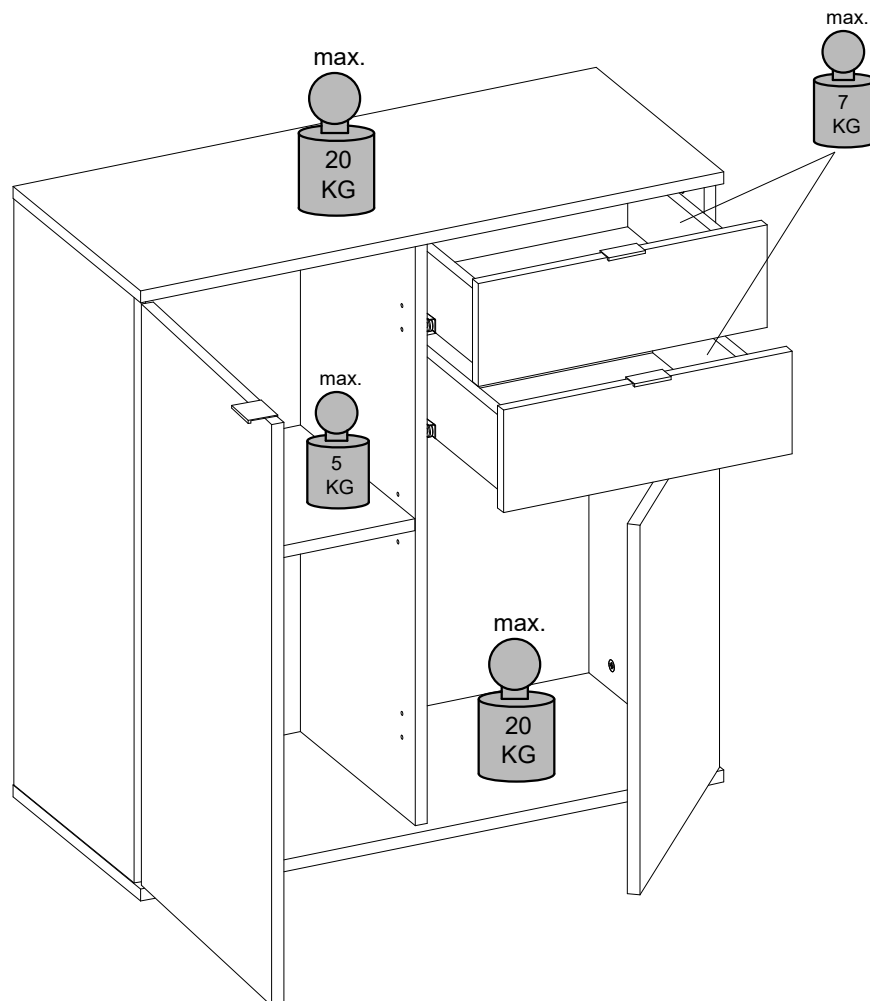
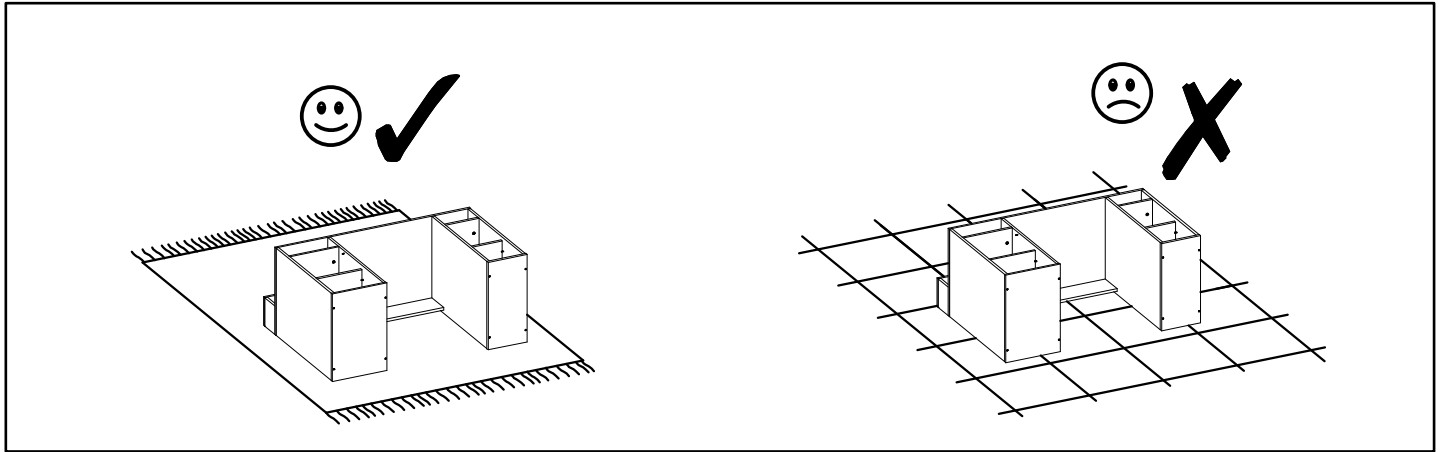
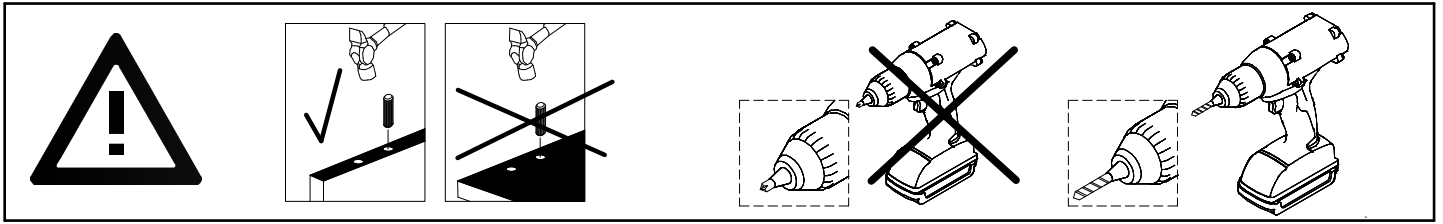
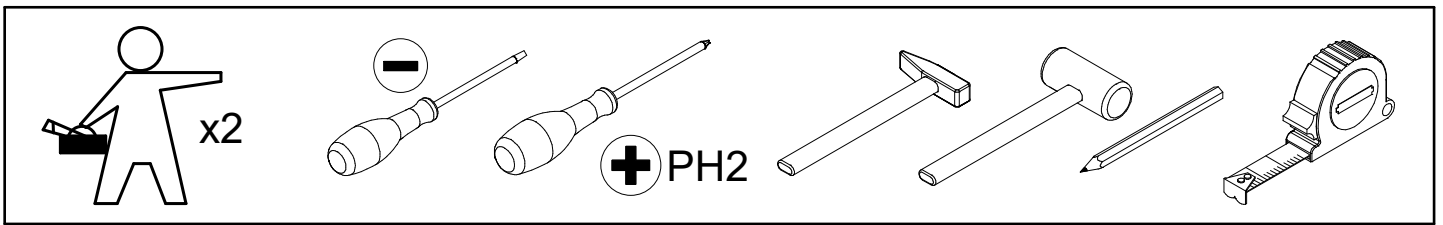

Service · Assistenza · Dienstverlening · Serwis Servis · Szerviz · Сервисная служба · Сервис · Serwis · Servis

Name · Nom · Nome · Naam ·
 Nazwa · Jméno · Názov · Név ·
 Denumire · Isim · Название

Tetris

Typ · Type · Tip · Típus · Tipo ·
 Тип

04

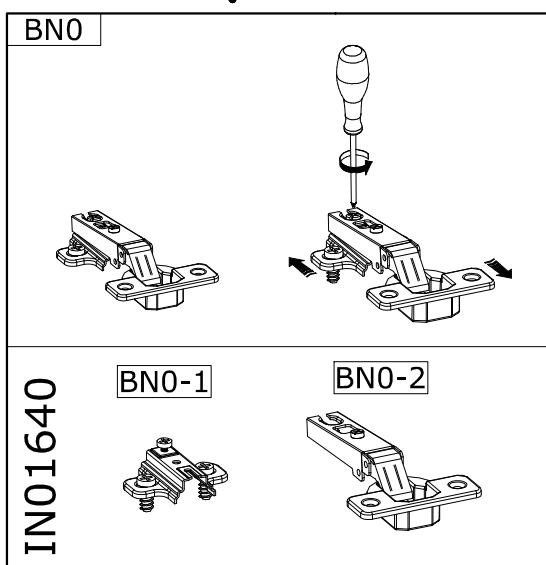
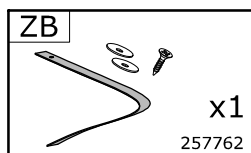
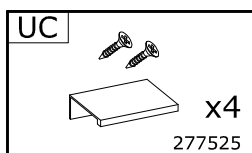
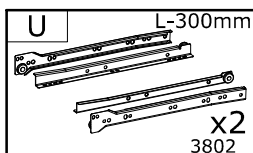
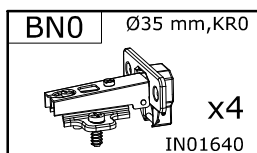
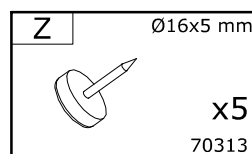
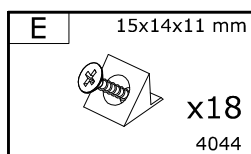
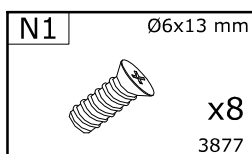
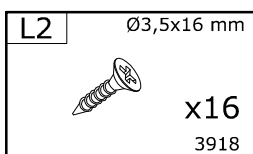
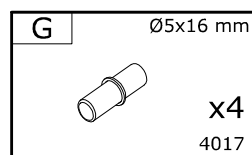
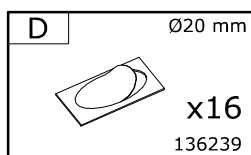
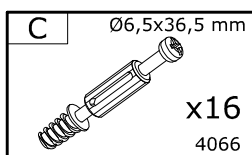
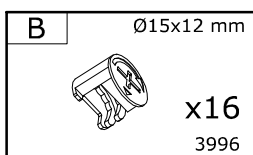
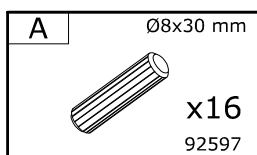
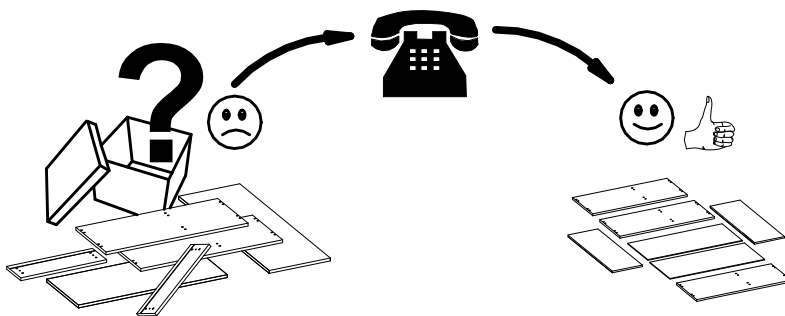
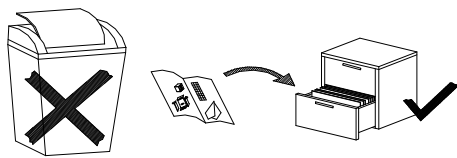

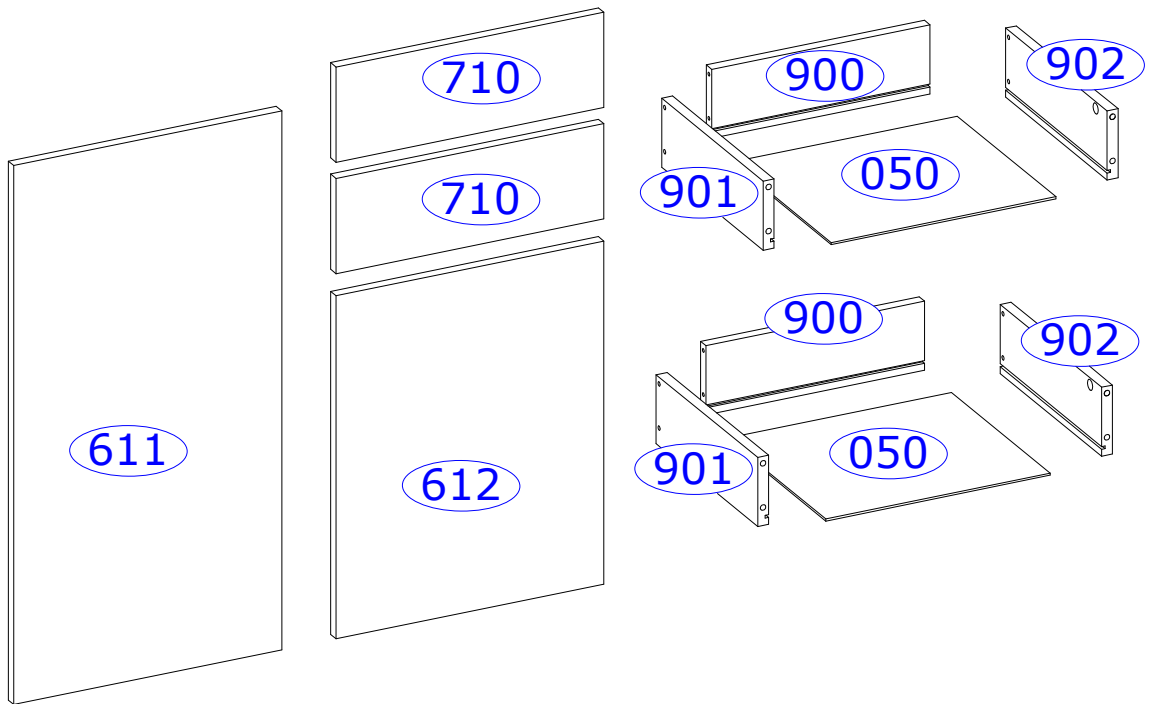
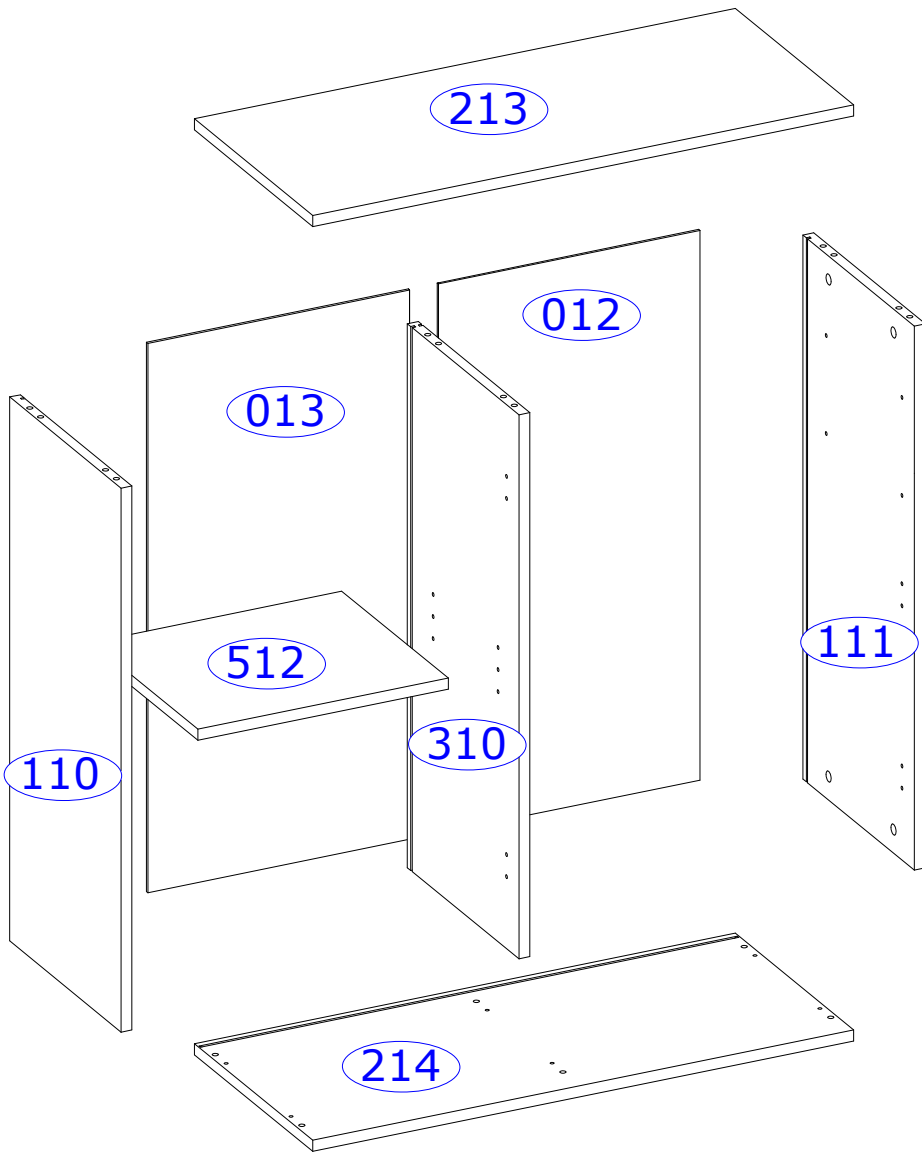

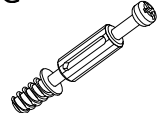

1

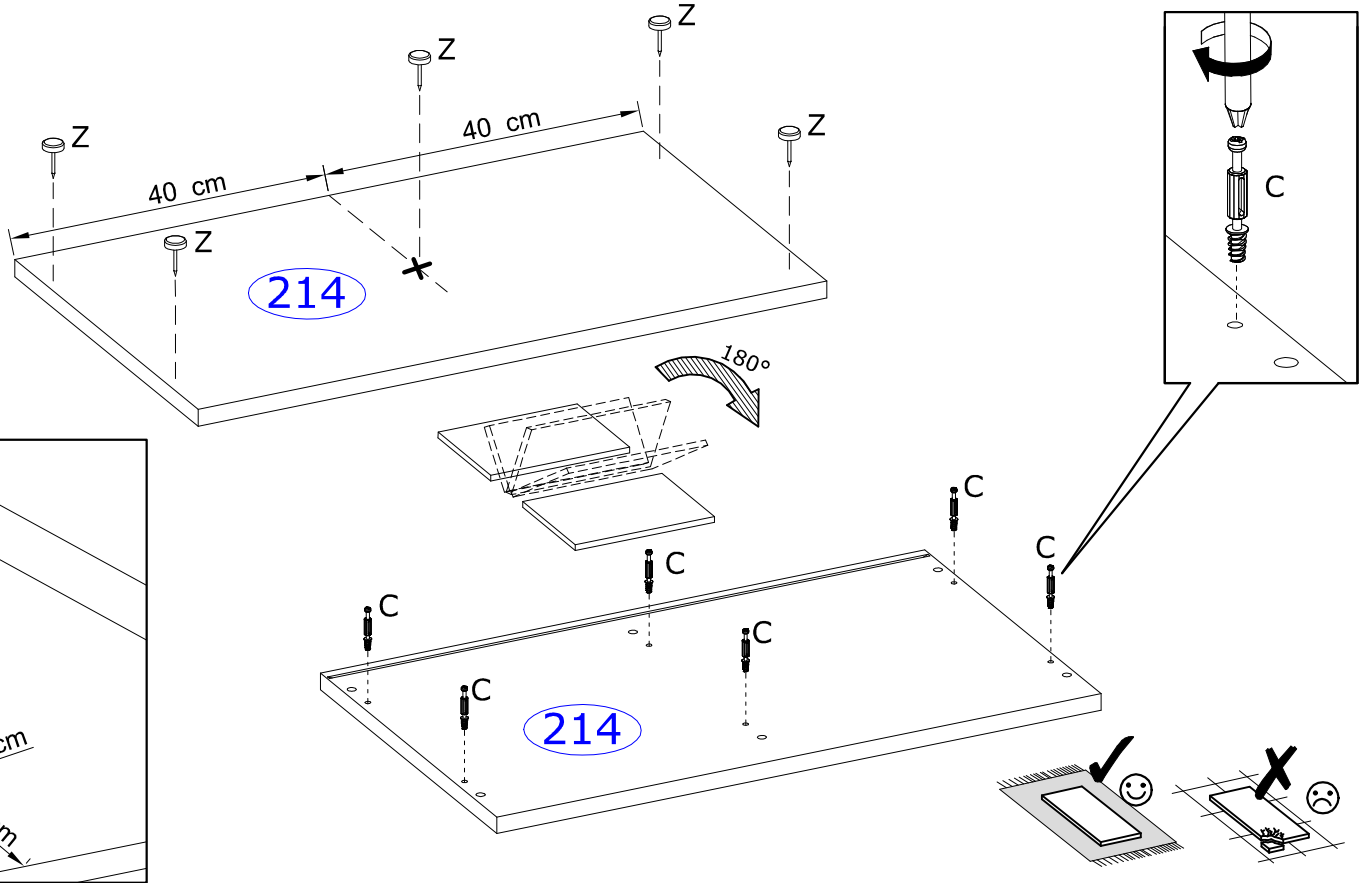
Z	Ø16x5 mm	C	Ø6,5x36,5 mm	
	x5 70313		x6 4066	

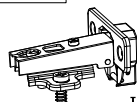

2

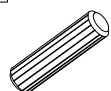
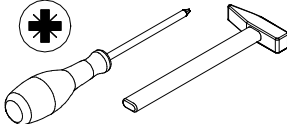
BNO	Ø35 mm, KR0	G	Ø5x16 mm	A	Ø8x30 mm	
	x2 IN01640		x2 4017		x4 92597	

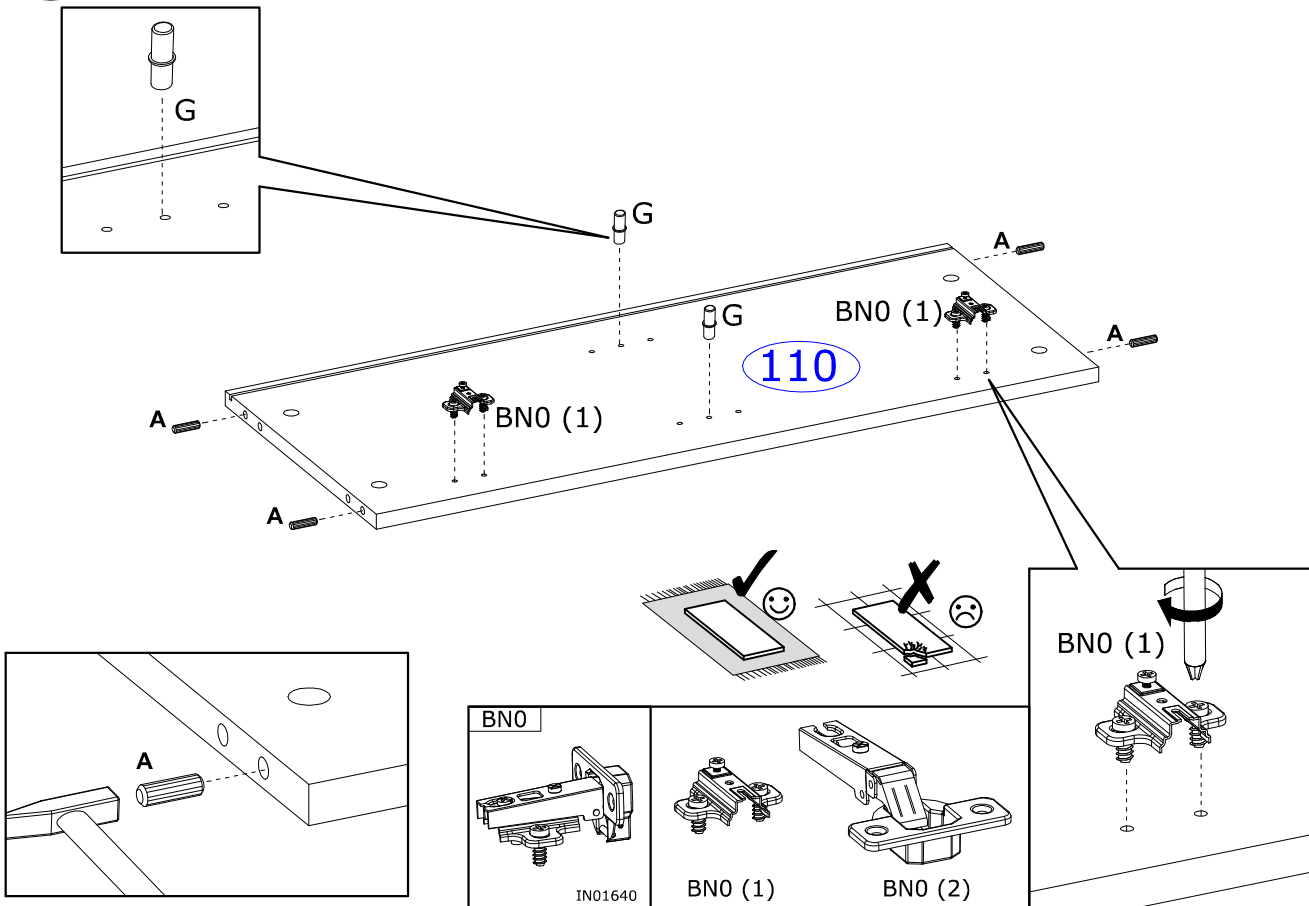

3

<p>U L-300mm x2 3802</p>	<p>N1 Ø6x13 mm x4 3877</p>	<p>A Ø8x30 mm x4 92597</p>	<p>G Ø5x16 mm x2 4017</p>	
----------------------------------	--	--	---------------------------------------	--

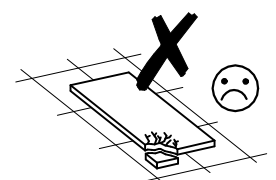
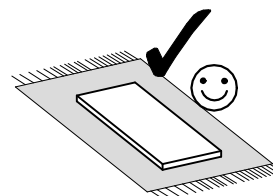
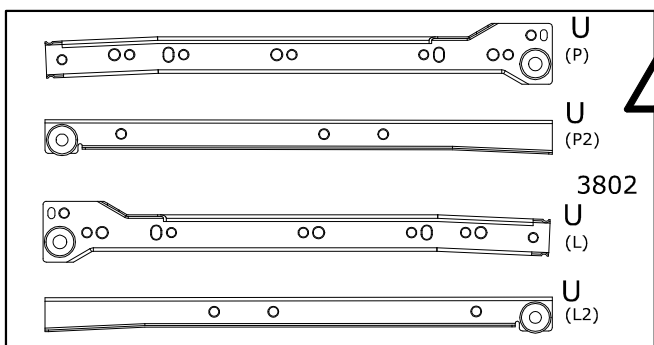
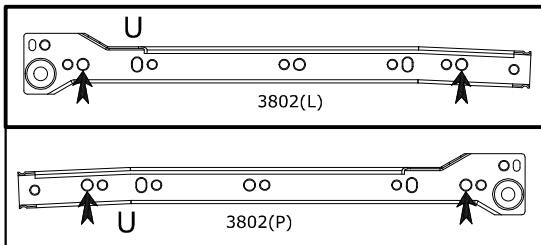
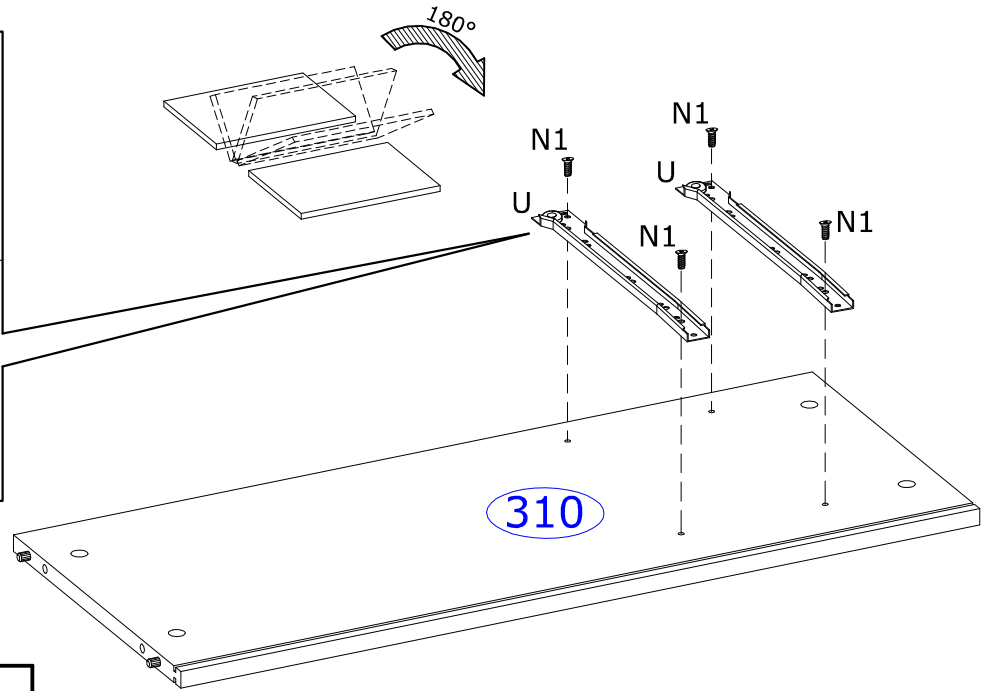
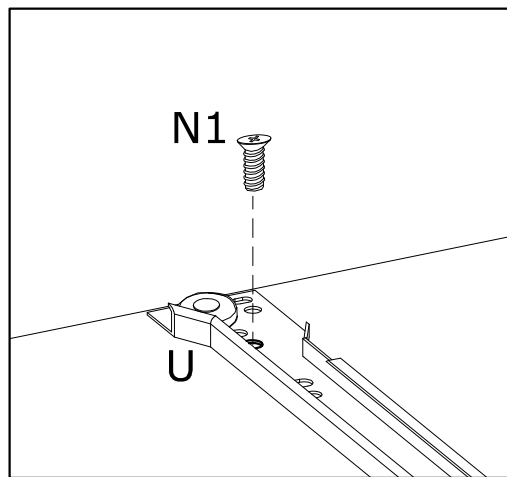
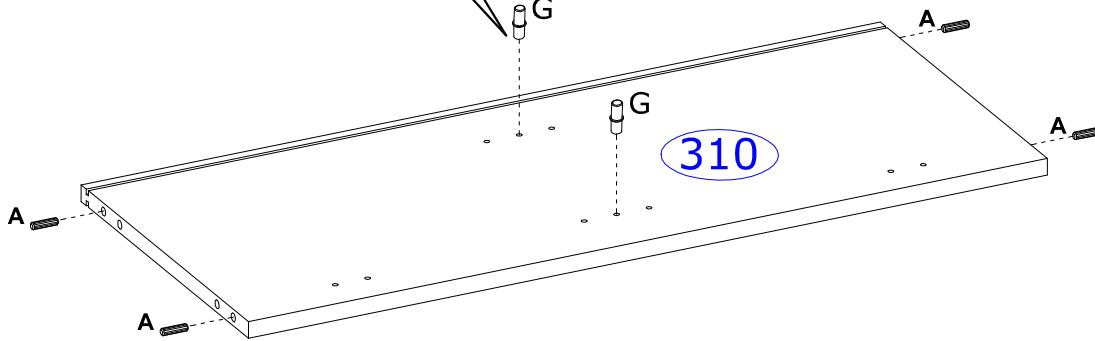
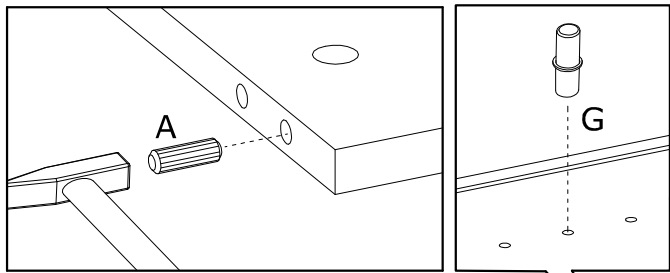

4

U	L-300mm x2 3802	N1	Ø6x13 mm x4 3877	A	Ø8x30 mm x4 92597	BN0	Ø35 mm, KR0 x2 IN01640	
---	-----------------------	----	------------------------	---	-------------------------	-----	------------------------------	--

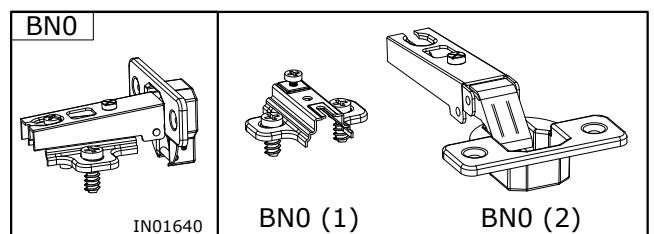
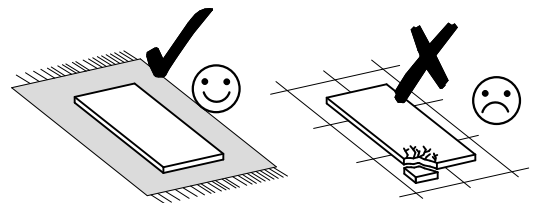
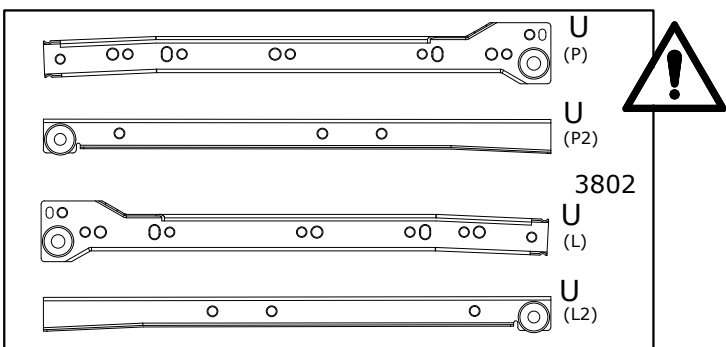
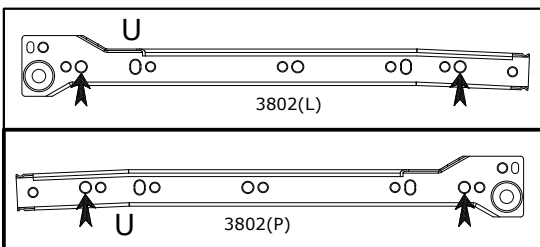
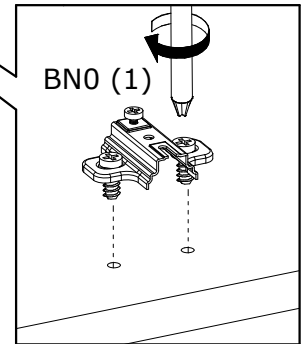
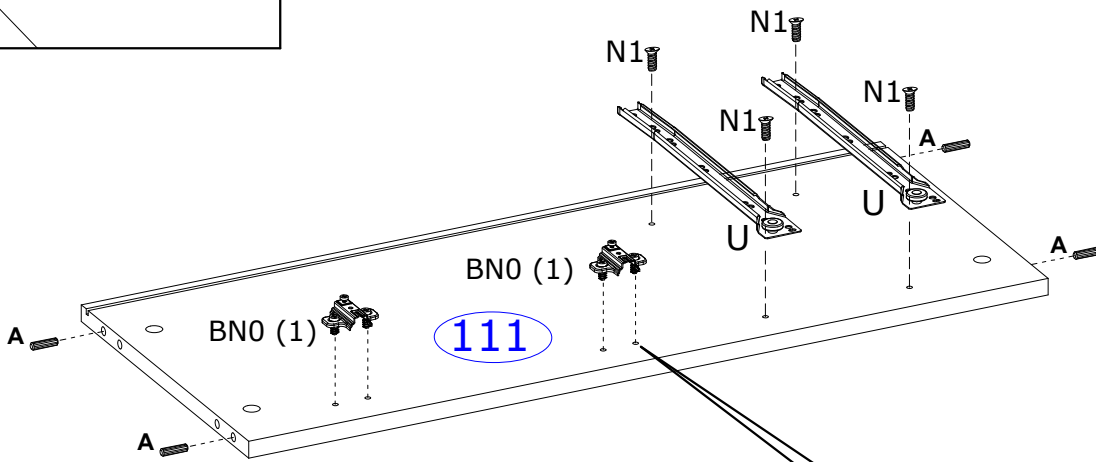
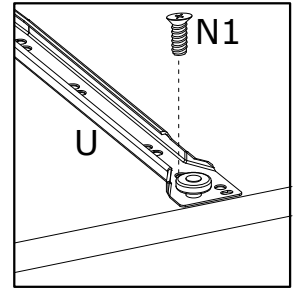
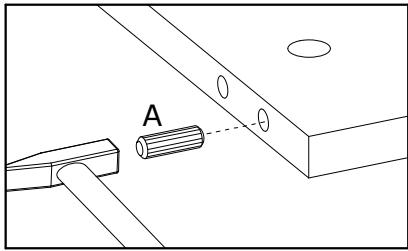

5

B Ø15x12 mm
x6
3996

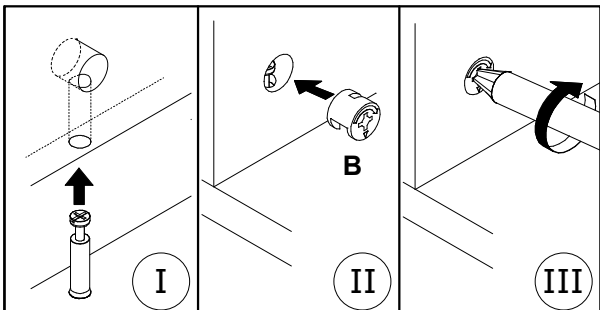
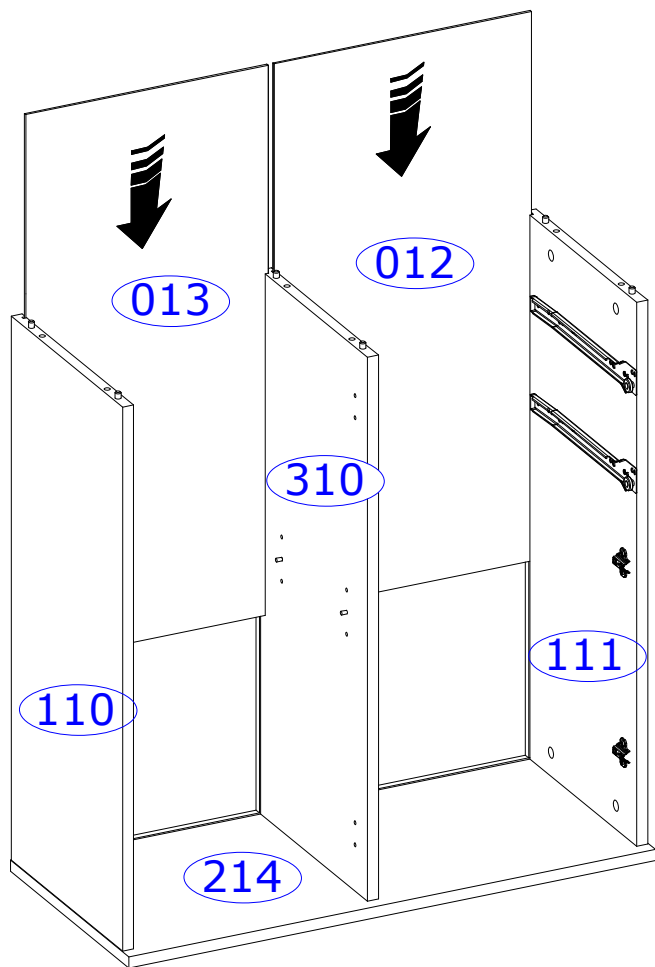
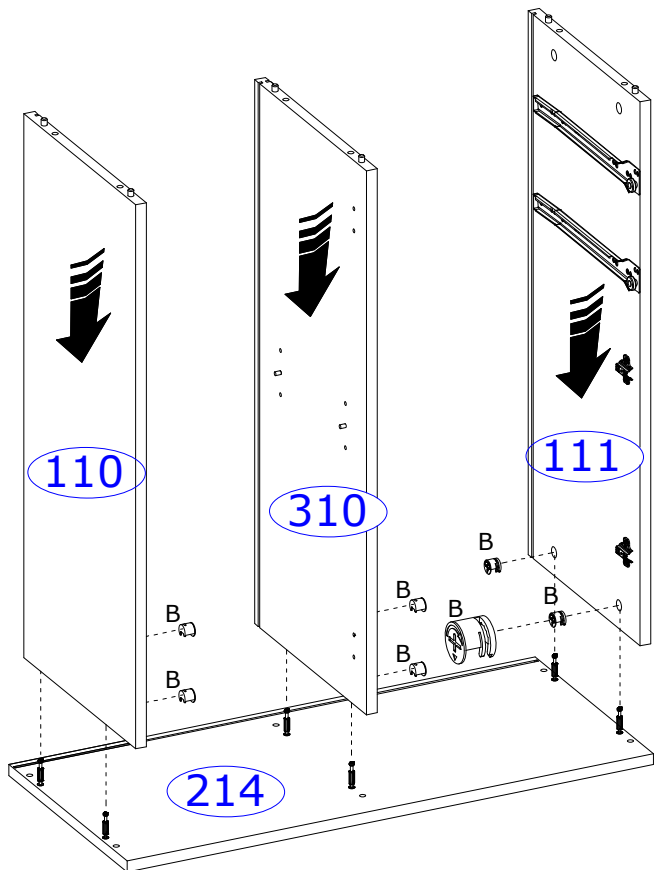
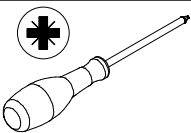

6

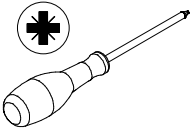
B Ø15x12 mm  x6 3996	C Ø6,5x36,5 mm  x6 4066	
---	--	--

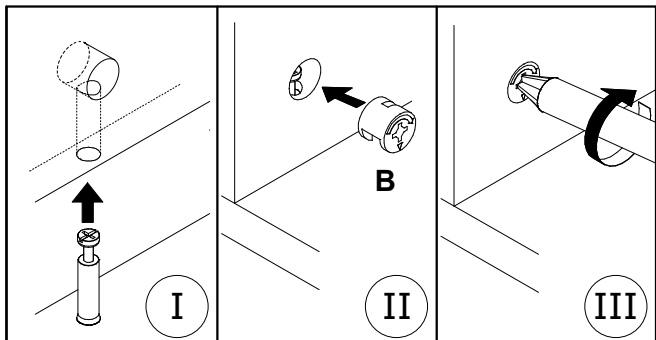
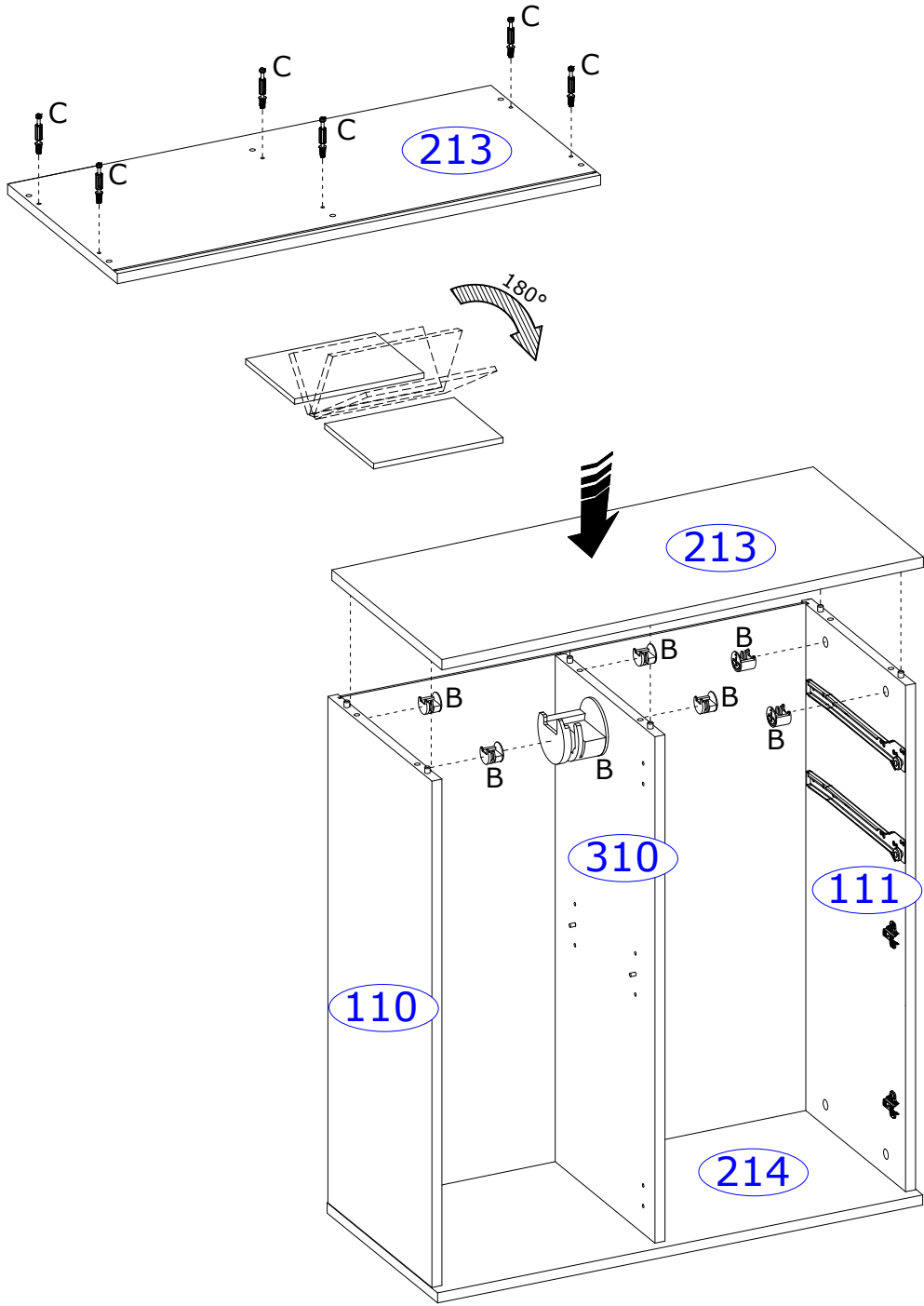

7

E 15x14x11 mm
x18
4044

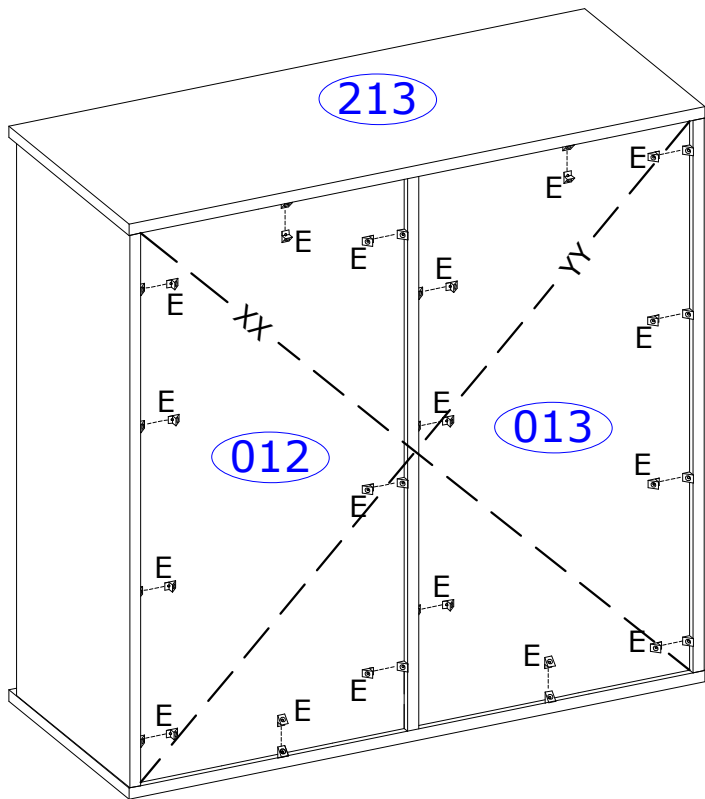
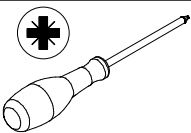

XX=YY≅90°

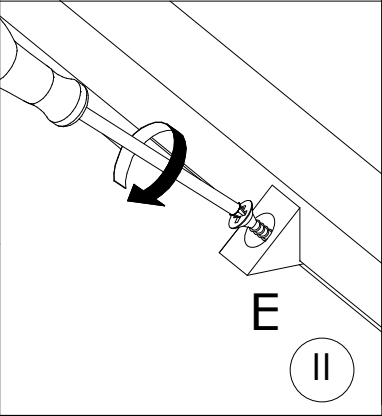
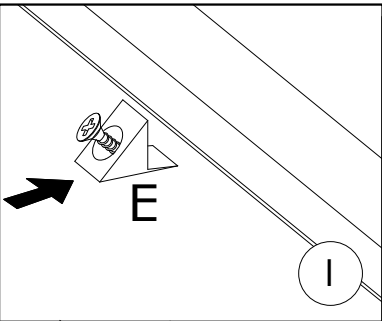

8

BN0 Ø35 mm, KR0
x2
IN01640

L2 Ø3,5x16 mm
x4
3918

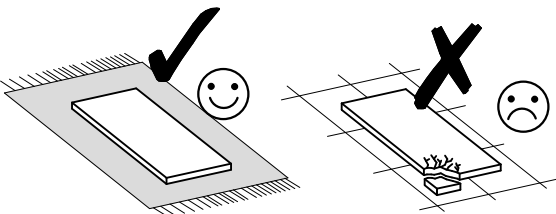
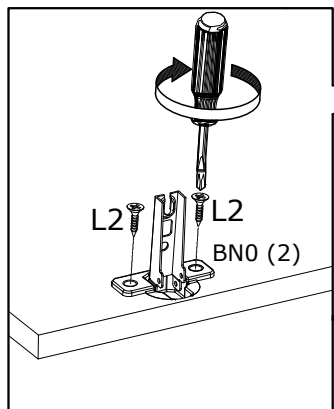
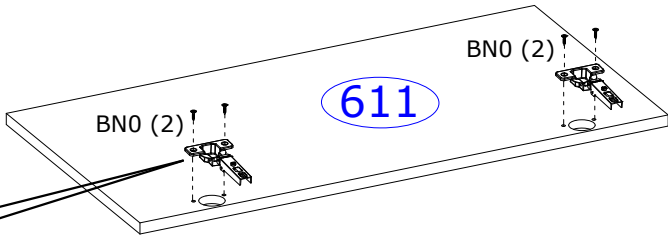
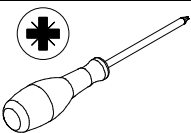

9

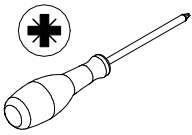
BNO	Ø35 mm, KR0	L2	Ø3,5x16 mm	
	x2 IN01640		x4 3918	

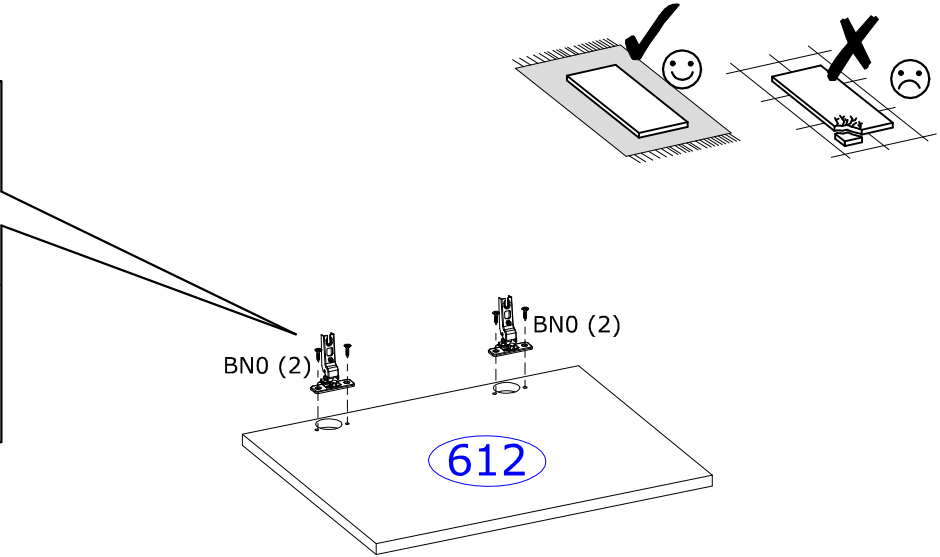
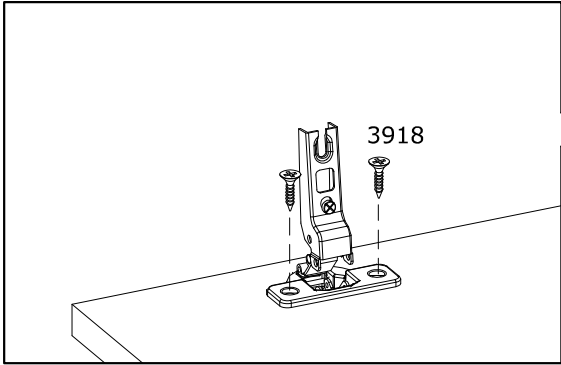

10

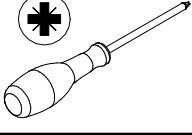
UC		x2 277525	
-----------	---	--------------	---

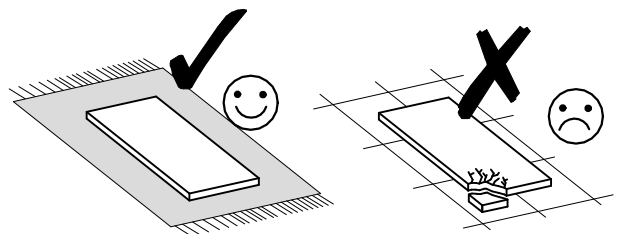
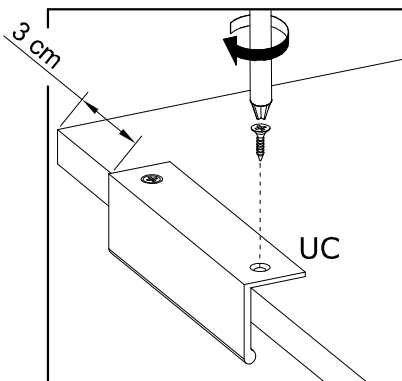
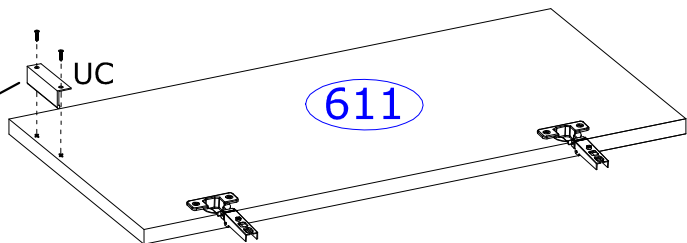
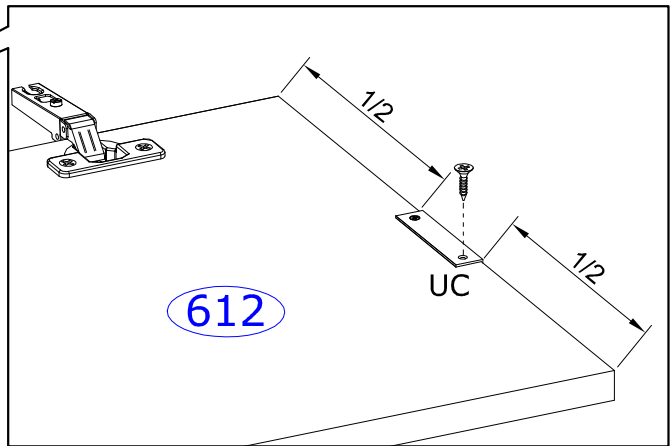
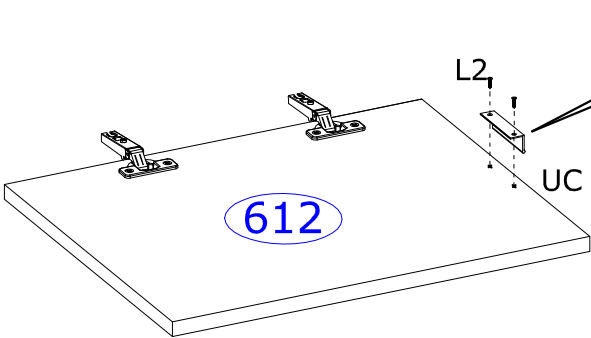

11

A
Ø8x30 mm
x4
92597

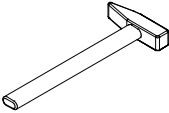

x2

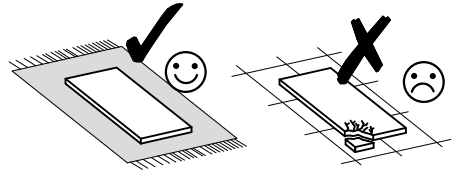
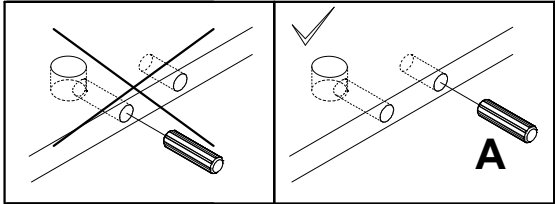
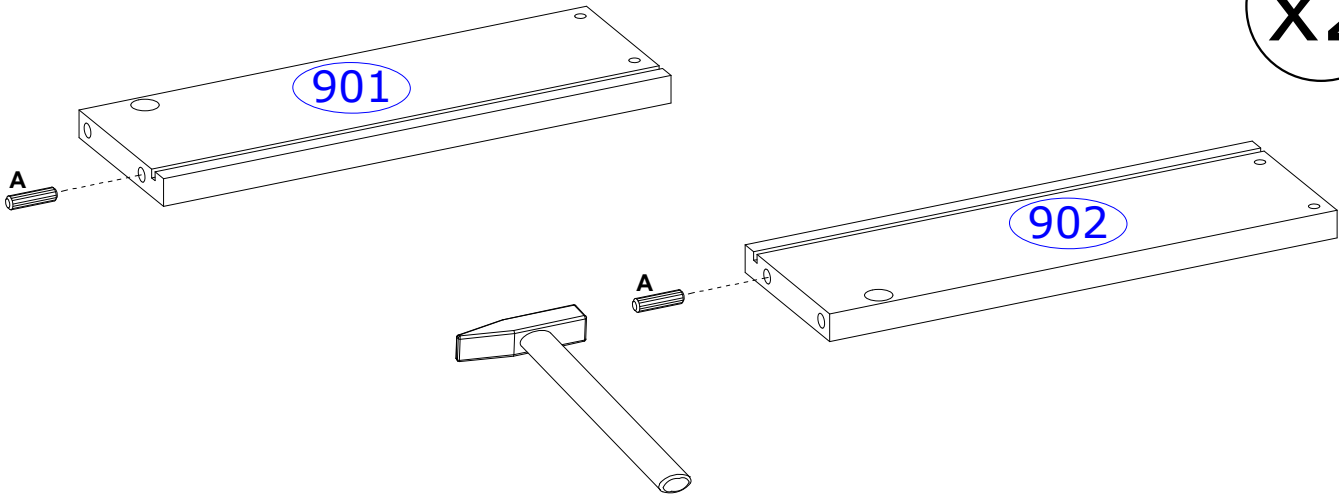

12

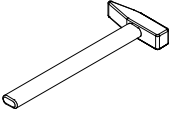

S
Ø12x42 mm
x8
INO1157

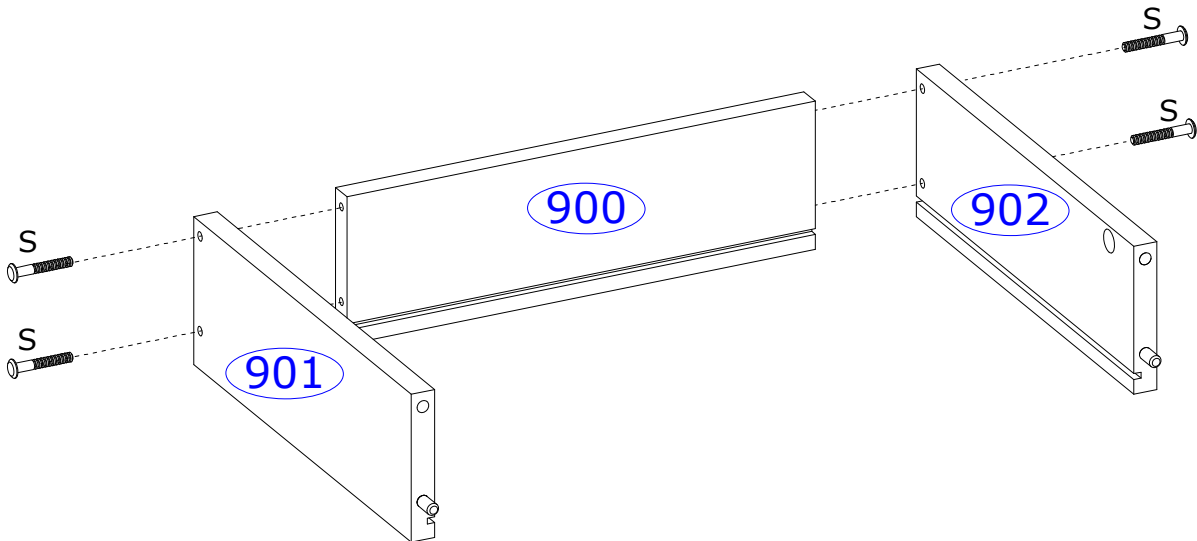

x2

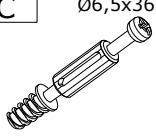

13

C	Ø6,5x36,5 mm	UC
	x4 4066	
		x2 277525

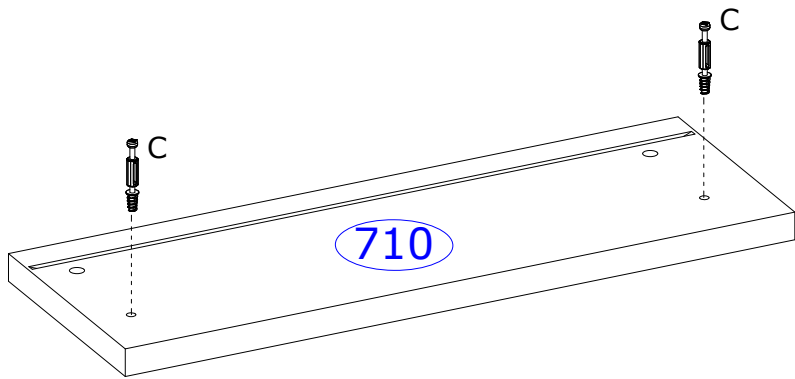
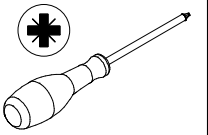

x2

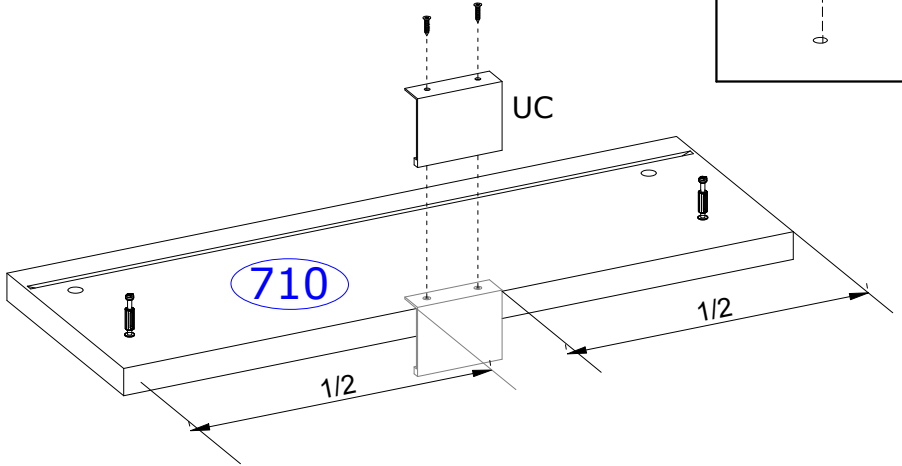
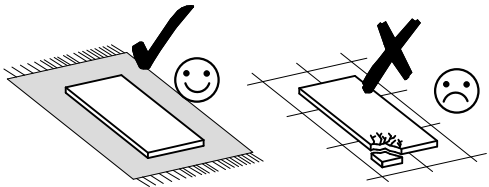
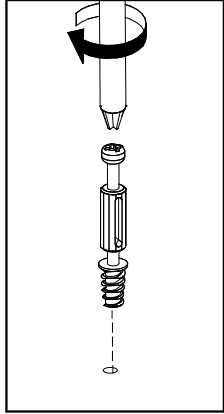

14

B	Ø15x12 mm	
	x4 3996	

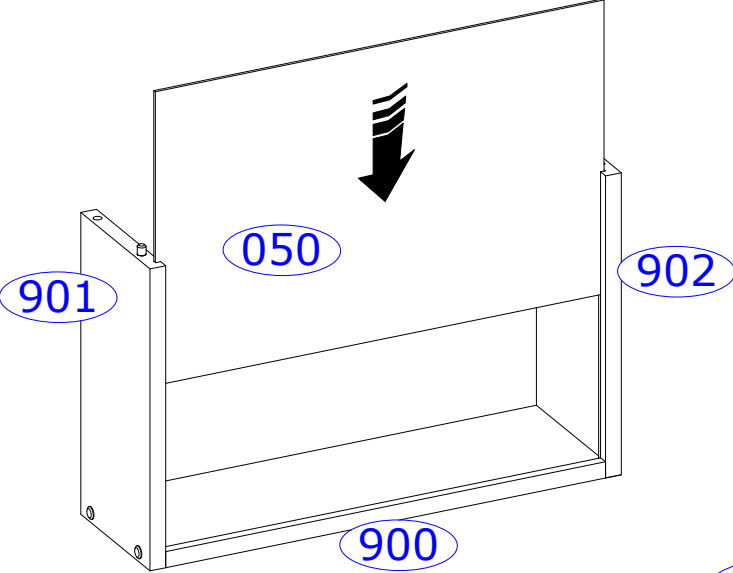
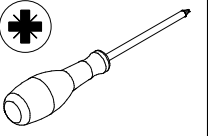

x2

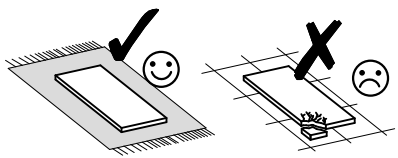
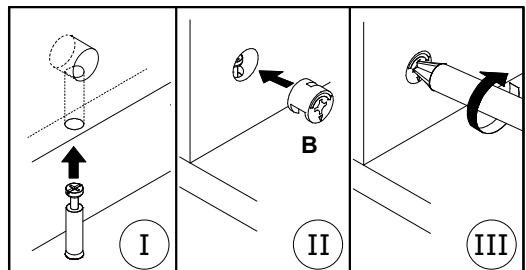
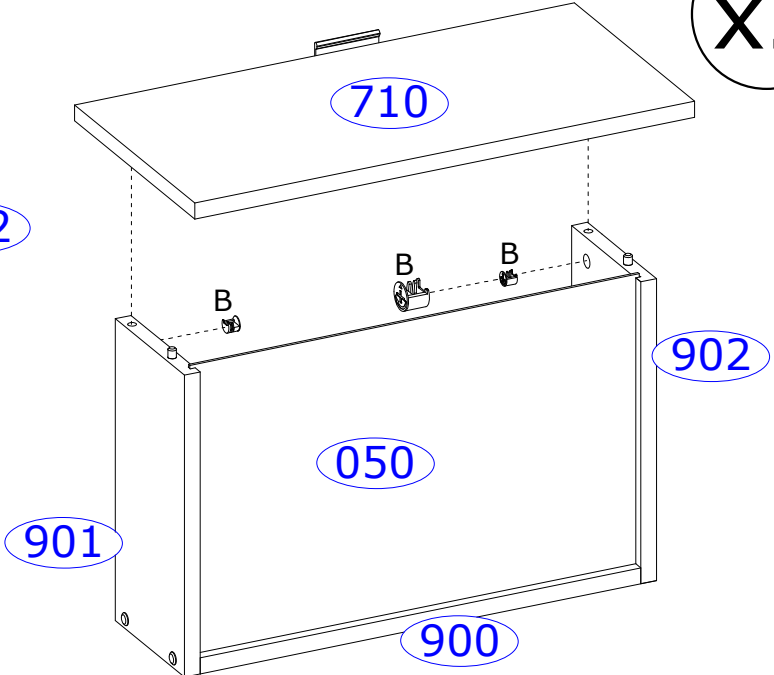

15

L2

Ø3,5x16 mm



x8

3918

U

L-300mm

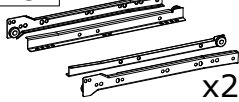

x2

3802

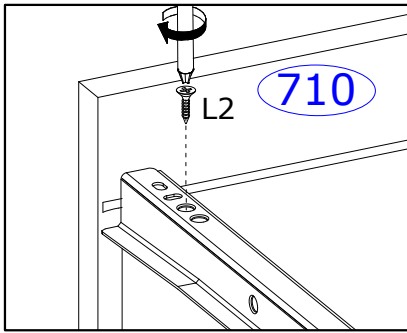
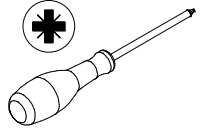

710

x2

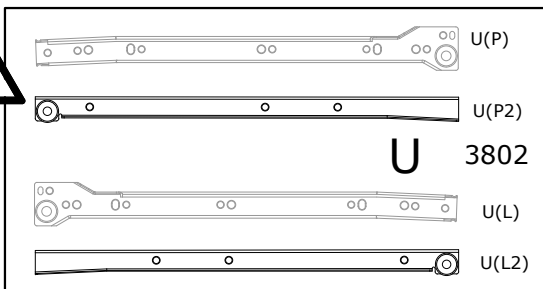
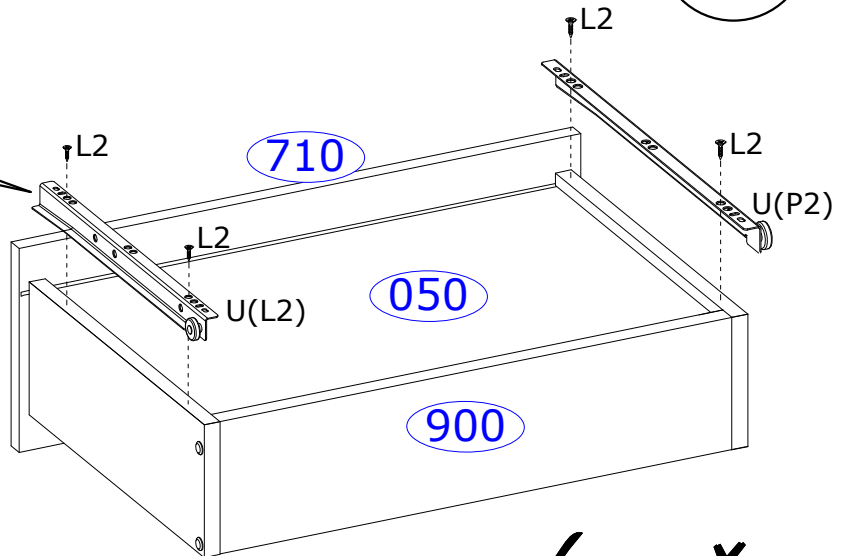

U(P)

U(P2)

U 3802

U(L)

U(L2)

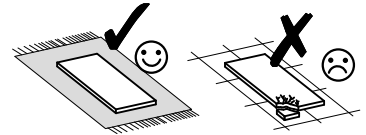

16

ZB

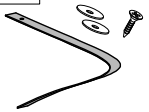

x1

257762

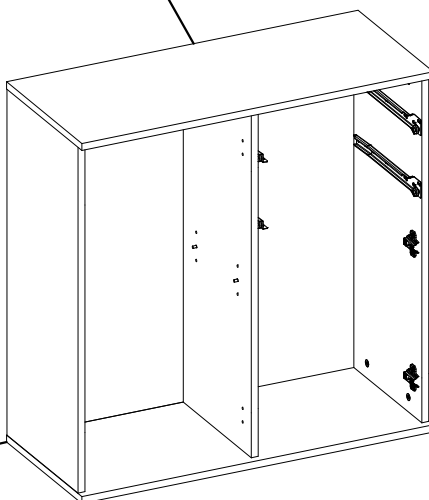
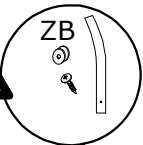
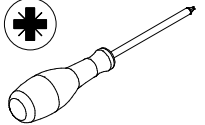

ACHTUNG - WARNING - ATTENTION - ATTENZIONE - AANDACHT - UWAGA - POZOR - POZOR - FIGYELEM - ATENȚIE - ДІККАТ - ВНИМАНИЕ - ПАЖЬЯ - PAŽNJA - POZOR - DĚMESIO - UZMANĪBU - TĀHELEPANU - ATENCIÓN - ATENÇÃO

D - ACHTUNG: WARNUNG Umkippen zu vermeiden, muss dieses Produkt mit der mitgelieferten Wandhalterung verwendet werden.

GB - WARNING: WARNING In order to prevent overturning this product must be used with the wall attachment device provided.

FR - ATTENTION: AVERTISSEMENT Pour éviter le renversement, ce produit doit être utilisé avec le support de montage mural fourni.

IT - ATTENZIONE: AVVERTENZA Per evitare il ribaltamento, questo prodotto deve essere utilizzato con una staffa di montaggio a parete inclusa.

NL - AANDACHT: WAARSCHUWING Om kantelen te voorkomen, moet dit product worden gebruikt met de meegeleverde wandmontagebeugel.

PL - UWAGA: OSTRZEŻENIE Aby zapobiec przewróceniu, produkt ten musi być używany z dołączonym uchwytem do montażu ściennego.

CZ - POZOR: UPOZORNĚNÍ Aby se zabránilo převrácení, musí být tento výrobek používán s dodaným držákem pro montáž na stěnu.

SK - POZOR: OPOZORILO Da bi preprečili prevračanje, je treba ta izdelek uporabljati s priloženim nosilcem za pritrditev na steno.

HU - FIGYELEM: FIGYELMEZTETÉS A billenés megakadályozása érdekében ezt a terméket a mellékelt fali rögzítő konzollal kell használni.

RO - ATENȚIE: AVERTISMENT Pentru a preveni răsturnarea, acest produs trebuie să fie utilizat cu suportul de montare pe perete furnizat.

TR - DIKKAT: UYARI Devrilmeyi önlemek için, bu ürün birlikte verilen duvara montaj braketi ile kullanılmalıdır.

RU - ВНИМАНИЕ: ПРЕДУПРЕЖДЕНИЕ Для предотвращения опрокидывания, этот продукт необходимо использовать с прикрепленным кронштейном для настенного монтажа.

SRB - ПАЖЬЯ: УПОЗОРЕЊЕ Да бисте спречили превртање, овај производ мора да се користи са укљученом зидним заградом за монтажу.

HR - PAŽNJA: UPOZORENJE Da biste spriječili prevrtanje, ovaj se proizvod mora koristiti s priloženim zidnim nosačem.

SL - POZOR: UPOZORNENIE Aby sa zabránilo prevráteniu, tento výrobok sa musí používať s dodanou nástennou montážnou konzolou.

LT - DĚMESIO: ĮSPĖJIMAS Kad šis gaminyas neapvirtu, jis turi būti naudojamas su pridedamu sieniniu laikikliu.

LV - UZMANĪBU: BRĪDINĀJUMS Lai novērstu apgāšanos, šis izstrādājums jāizmanto kopā ar pievienoto sienas stiprinājuma kronšteinu.

EE - TĀHELEPANU: HOIATUS Kukkumise vältimiseks tuleb seda toodet kasutada koos kaasasoleva seinakinnitusklambriga.

ES - ATENCIÓN! ADVERTENCIA Para evitar que se vuelque, este producto debe utilizarse con el soporte de montaje en pared proporcionado.

PT - ATENÇÃO! AVISO Para evitar o tombamento, este produto deve ser utilizado com o suporte de montagem na parede fornecido.

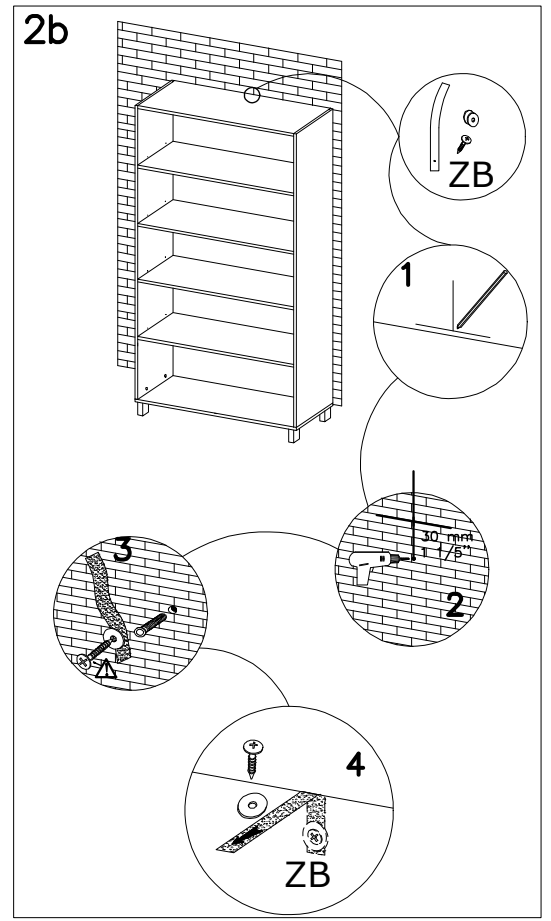
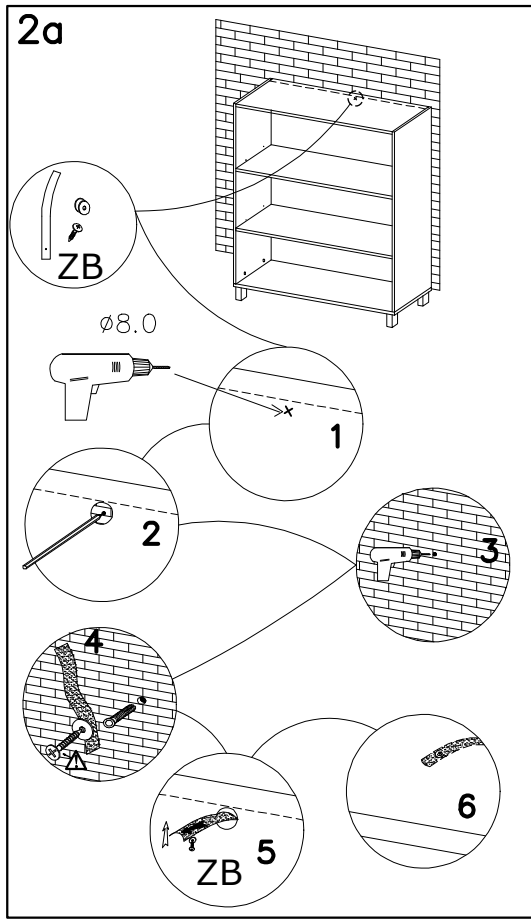
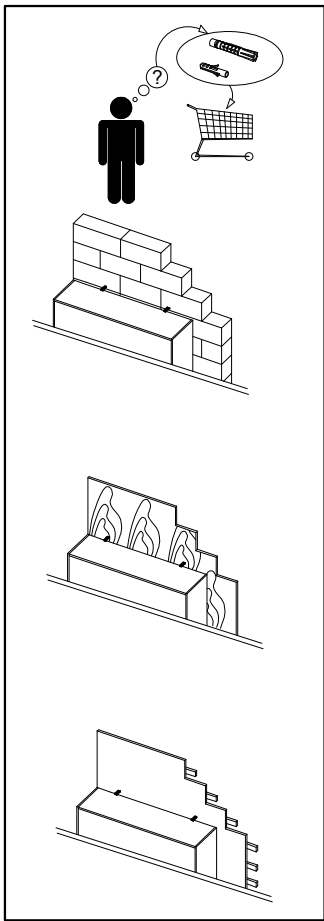

17

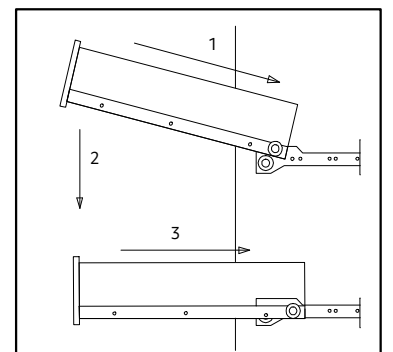
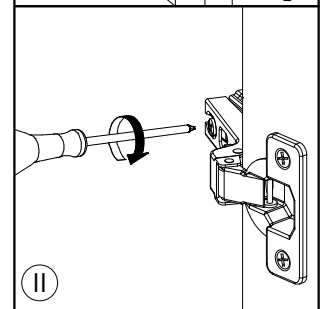
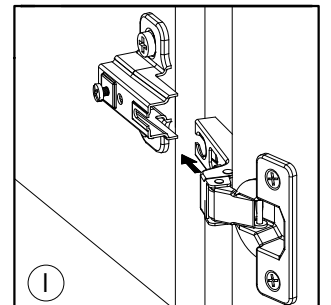
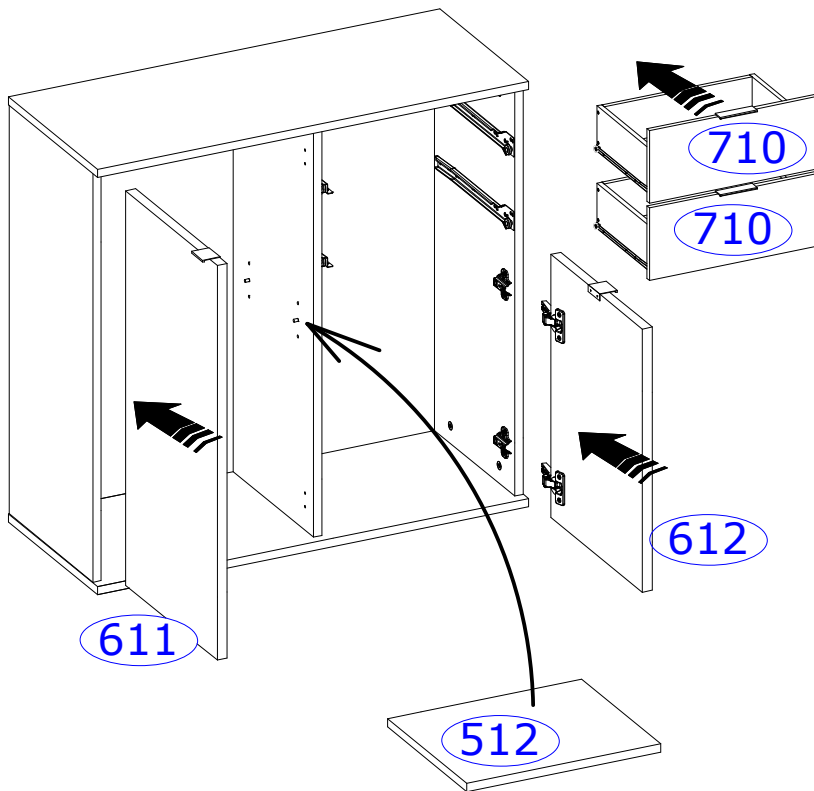

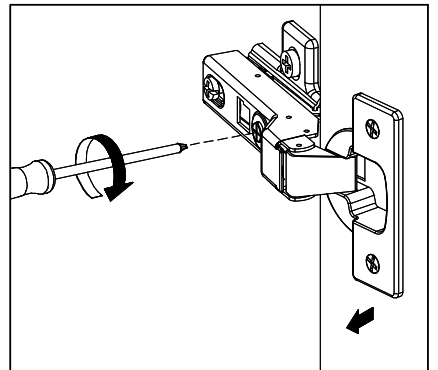
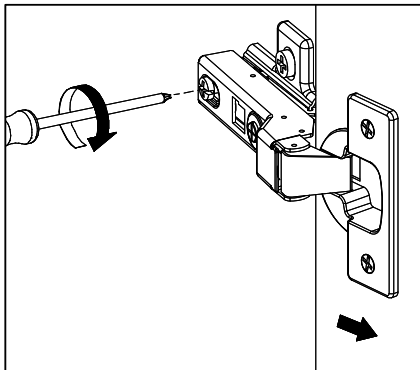
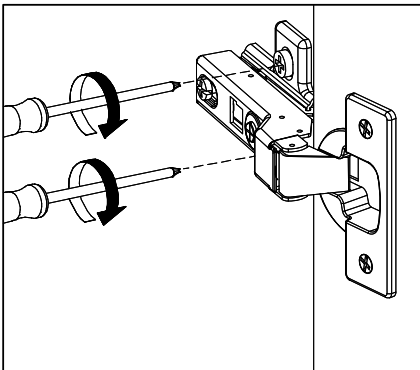
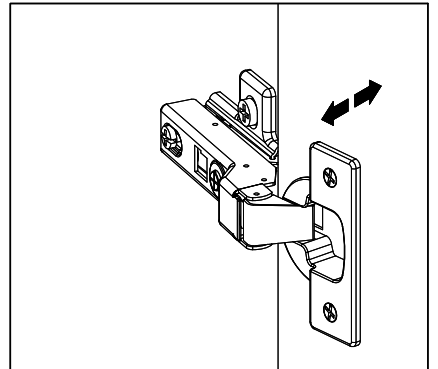
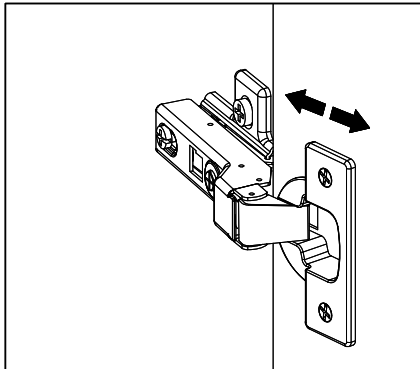
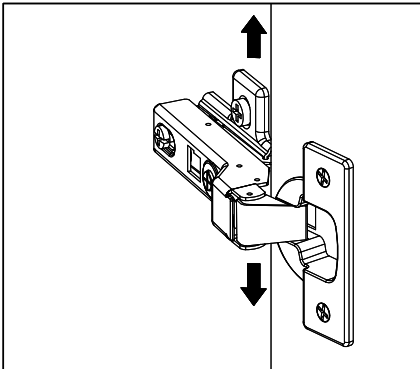
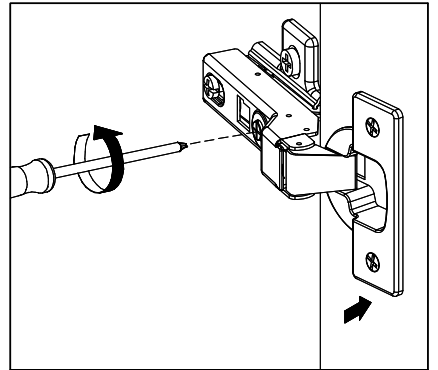
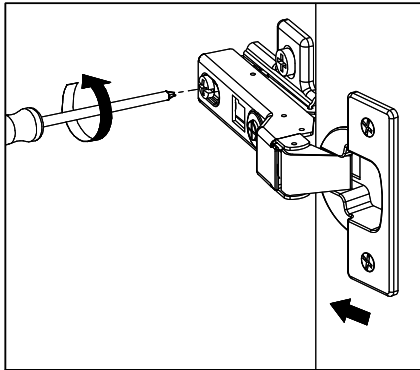
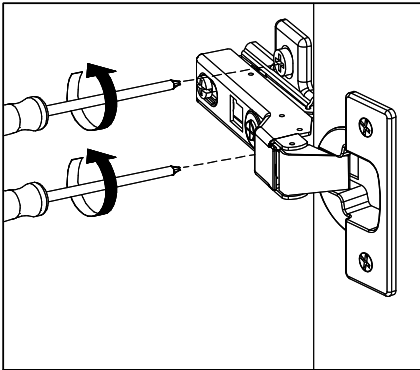
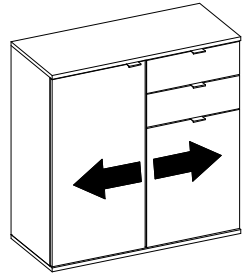
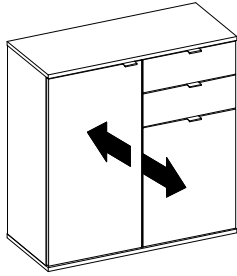
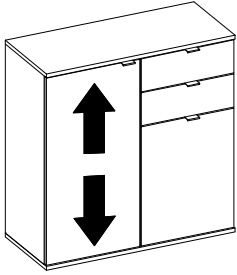

- | | |
|--|--|
| D Sicherheits- und Pflegehinweise | GB Safety and maintenance tips |
| FR Conseils de sécurité et d'entretien | IT Consigli per la sicurezza e la manutenzione |
| NL Veiligheids- en onderhoudstips | PL Wskazówki dotyczące bezpieczeństwa i konserwacji |
| CZ Tipy pro bezpečnost a údržbu | SK Tipy na bezpečnosť a údržbu |
| HU Biztonsági és karbantartási tanácsok | RO Sfaturi de siguranță și întreținere |
| TR Güvenlik ve bakım ipuçları | RU Советы по безопасности и обслуживанию |
| ES Instruções de segurança e manutenção | PT Instruções de segurança e manutenção |
| SRB Савети за безбедност и одржавање | HR Savjeti za sigurnost i održavanje |
| SL Nasveti za varnost in vzdrževanje | LT Saugos ir priežiūros patarimai |
| LV Drošības un apkopes padomi | EE Ohutus- ja hooldusnõuanded |
| BA Savjeti za sigurnost i održavanje | BG Съвети за безопасност и поддръжка |

